

**GENERAL MEETING OF THE BOARD OF DIRECTORS
OF THE
CENTRAL TEXAS REGIONAL MOBILITY AUTHORITY**

RESOLUTION NO. 21-011

**APPROVING A CONTRACT WITH GREAT HILLS CONSTRUCTORS TO DESIGN
AND CONSTRUCT THE 183 NORTH MOBILITY PROJECT**

WHEREAS, by Resolution No. 17-023, dated April 26, 2017, the Central Texas Regional Mobility Authority Board of Directors (Board) exercised its option as a local toll project entity to develop, finance, construct, and operate the 183 North Mobility Project that includes construction of two express lanes in each direction along a 9-mile stretch of US 183 between SH 45/RM 620 and Mo Pac, the addition of a fourth general purpose lane in each direction and connections from the 183 North Express Lanes to the MoPac Express Lanes, as well as new shared use path connections, new sidewalks, and cross-street connections for bicycles/pedestrians; and

WHEREAS, by Resolution No. 21-005, dated February 8, 2021, the Board awarded a contract to design and construct the 183 North Mobility Project to Great Hills Constructors, a joint venture between Archer Western Construction, LLC and Sundt Construction, Inc.; and

WHEREAS, contingent upon receiving concurrence in the award from the Federal Highway Administration and the Texas Department of Transportation, the Board directed the Interim Executive Director to negotiate a design-build contract for 183 North Mobility Project with Great Hills Constructors and to present the proposed design-build contract to the Board for its approval once an agreement was reached; and

WHEREAS, the Interim Executive Director and Great Hills Constructors have negotiated a proposed contract for the design and construction of the 183 North Mobility Project in an amount not to exceed \$477,149,654 which is attached hereto as Exhibit A; and

WHEREAS, the Interim Executive Director recommends that the Board approve the proposed design-build contract with Great Hills Constructors for the 183 North Mobility Project in the form or substantially the same form attached hereto as Exhibit A.

NOW THEREFORE, BE IT RESOLVED, that the Board approves the contract to with Great Hills Constructors to design and construct the 183 North Mobility Project in an amount not to exceed \$477,149,654, and hereby authorizes the Interim Executive Director to finalize and execute the design-build contract with Great Hills Constructors on behalf of the Mobility Authority in the form or in substantially the same form attached hereto as Exhibit A.

Adopted by the Board of Directors of the Central Texas Regional Mobility Authority on the 24th day of February 2021.

Submitted and reviewed by:

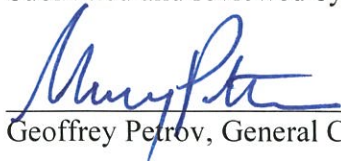

Geoffrey Petrov, General Counsel

Approved:

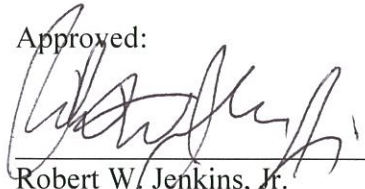

Robert W. Jenkins, Jr.
Chairman, Board of Directors

Exhibit A

183 North Mobility Project

Project Number: 20183N22701C

DESIGN-BUILD AGREEMENT

Dated as of _____, 2021

By and Among

Central Texas Regional Mobility Authority,
a regional mobility authority operating pursuant to
Texas Transportation Code Chapter 370

and

Great Hills Constructors,
a joint venture between Archer Western Construction, LLC
and Sundt Construction, Inc.



EXECUTION COPY

Table of Contents

1.	CONTRACT COMPONENTS	2
	1.1 Certain Definitions.....	2
	1.2 Order of Precedence.....	3
	1.3 Referenced Standards.....	4
2.	GENERAL FRAMEWORK AND OUTLINE OF TRANSACTION.....	4
	2.1 Type of Transaction	4
	2.2 Role of Parties to Transaction.....	4
	2.3 Partnering.....	7
3.	SCOPE OF WORK; ROLE OF THE PARTIES AND LOCAL AGENCIES; EFFECT OF TESTS AND INSPECTIONS	7
	3.1 Work Scope.....	7
	3.2 Project Location and Description.....	8
	3.3 Project Management Plan	8
	3.4 Mobility Authority's Role	8
	3.5 Local Agencies' Roles	8
	3.6 DB Contractor Obligations	9
	3.7 Effect of Reviews, Inspections, Tests, and Acceptances	11
4.	INFORMATION SUPPLIED TO THE DB CONTRACTOR; ACKNOWLEDGMENT BY THE DB CONTRACTOR.....	11
	4.1 Information Supplied	11
	4.2 Acknowledgment by the DB Contractor.....	11
	4.3 Changes in Basic Configuration	13
5.	TIME WITHIN WHICH PROJECT SHALL BE COMPLETED; PROJECT SCHEDULE AND PROGRESS.....	14
	5.1 Time of Essence; Notices to Proceed.....	14
	5.2 Guaranteed Completion	14
	5.3 Project Schedule.....	15
	5.4 Project Schedule Submittals	15
	5.5 Recovery Schedule.....	16
	5.6 Float	17
6.	RIGHT OF WAY SERVICES.....	17
	6.1 Acquisition of Final ROW	17
	6.2 Costs of Acquisitions	17
	6.3 Limiting Acquisition of Additional Properties	18
	6.4 Representations by the DB Contractor	19
	6.5 Negotiations and Condemnation Proceedings Relative to the Acquisition of DB Contractor-Designated ROW	19
	6.6 Physical Possession of Final ROW; Failure by the Mobility Authority to Make Schematic ROW Available	20
	6.7 Rights of Early Access.....	21

Table of Contents

7.	COMMENCEMENT OF CONSTRUCTION; CONSTRUCTION PROCEDURES; HAZARDOUS MATERIALS; NEW ENVIRONMENTAL APPROVALS.....	21
	7.1 Commencement of Construction	21
	7.2 Supervision and Construction Procedures	22
	7.3 Inspection and Testing	22
	7.4 Correction of Nonconforming Work	23
	7.5 Hazardous Materials Management	24
	7.6 Environmental Compliance	27
8.	DISADVANTAGED BUSINESS ENTERPRISE; CIVIL RIGHTS	28
	8.1 DBE Requirements	28
	8.2 Civil Rights	29
9.	PERFORMANCE AND PAYMENT SECURITY	29
	9.1 Proposal Bond.....	29
	9.2 Performance Bond	29
	9.3 Payment Bond.....	30
	9.4 Warranty Bond.....	30
	9.5 Surety Financial Requirements.....	30
	9.6 Performance by Surety or Guarantor	30
	9.7 Guarantee	30
10.	INSURANCE.....	31
	10.1 [Reserved].....	31
	10.2 Insurance After Issuance of NTP1	31
	10.3 General Insurance Requirements	34
	10.4 Mobility Authority’s Right to Remedy Breach by the DB Contractor.....	37
	10.5 Other Conditions.....	37
	10.6 Prosecution of Claims.....	38
	10.7 Commencement of Work.....	38
	10.8 Disclaimer	38
	10.9 Insurance During Warranty Period.....	38
11.	SITE SECURITY; RESPONSIBILITY FOR LOSS OR DAMAGE.....	39
	11.1 Site Security	39
	11.2 Risk of Loss or Damage; Maintenance and Repair of Work	39
12.	WARRANTIES	39
	12.1 Warranties.....	39
	12.2 Applicability of Warranties to Repaired, Replaced, or Corrected Work	41
	12.3 Subcontractor and Extended Warranties.....	41
	12.4 Effect of the Mobility Authority or Maintenance Contractor Activities on Warranties	42
	12.5 No Limitation of Liability.....	42
	12.6 Damages for Breach of Warranty	43
	12.7 Warranty Beneficiaries	43
	12.8 Transfer of Warranties to TxDOT	43

Table of Contents

13.	PAYMENT	43
	13.1 DB Price.....	43
	13.2 NTP1 and NTP2 Work Payments; Delay in Issuance of NTP1 and/or NTP2.....	44
	13.3 Payments.....	45
	13.4 Compensation for Early Completion	52
	13.5 Final Payment	52
	13.6 Taxes.....	54
	13.7 Value-Added Concepts	54
14.	CHANGES IN THE WORK	54
	14.1 Change Orders	55
	14.2 Procedure for Issuance of Change Orders by the Mobility Authority	57
	14.3 DB Contractor-Requested Change Orders.....	58
	14.4 Form and Contents of Change Orders	64
	14.5 Limitations on Change Orders	65
	14.6 Pricing of Change Orders.....	67
	14.7 Time and Materials Change Orders and Cost Data	68
	14.8 Hazardous Materials Management	72
	14.9 Differing Site Conditions.....	73
	14.10 Force Majeure Events	74
	14.11 Eliminated Work.....	75
	14.12 Utility Adjustment Work	75
	14.13 Restrictions and Limitations on Change Orders	82
	14.14 Disputes.....	83
	14.15 No-Cost Changes	83
	14.16 No Release or Waiver	84
	14.17 Concurrence by TxDOT and FHWA Representatives.....	84
	14.18 Discovery of Karst Features.....	84
15.	SUSPENSION OF ALL OR PART OF THE WORK.....	87
	15.1 Suspension for Convenience.....	87
	15.2 Suspension for Other Reasons, Including Compliance with Governmental Approvals	87
	15.3 Compensation and Time Extensions for Suspensions	87
16.	TERMINATION FOR CONVENIENCE.....	87
	16.1 DB Contractor’s Right to Terminate for Delay in Project Financing.....	87
	16.2 Mobility Authority’s Right to Terminate for Convenience	87
	16.3 Notice of Termination.....	88
	16.4 DB Contractor’s Responsibilities After Receipt of Notice of Termination.....	88
	16.5 Inventory	89
	16.6 Settlement Proposal	89
	16.7 Amount of Termination Settlement	89
	16.8 No Agreement as to Amount of Claim	90
	16.9 Reduction in Amount of Claim.....	90
	16.10 Preservation of Records	90
	16.11 Mobility Authority’s Unilateral Right to Issue NTPs.....	90

Table of Contents

17.	DEFAULT	91
	17.1 Default of the DB Contractor.....	91
	17.2 Remedies.....	93
	17.3 Failure to Comply Caused by Delay Event.....	95
	17.4 Right to Stop Work for Failure by the Mobility Authority to Make Undisputed Payment.....	95
18.	DAMAGES.....	96
	18.1 Liquidated Damages	96
	18.2 Payment Terms/Offset; Reduction; Waiver.....	97
	18.3 Limitation of DB Contractor’s Liability	97
19.	LABOR AND EMPLOYMENT REQUIREMENTS.....	98
	19.1 Key Personnel; Qualifications of Employees	98
	19.2 Responsibility for Employees and Subcontractors	100
	19.3 Subcontracts.....	100
20.	COMPLETION AND ACCEPTANCE.....	103
	20.1 Substantial Completion.....	103
	20.2 Final Acceptance.....	104
	20.3 Assignment of Causes of Action.....	106
21.	[RESERVED]	106
22.	REPRESENTATIONS AND WARRANTIES.....	106
	22.1 Mobility Authority Representations and Warranties	106
	22.2 DB Contractor Representations, Warranties, and Covenants	107
23.	INDEMNIFICATION; RELEASES.....	110
	23.1 Indemnification by the DB Contractor	110
	23.2 Restrictions	112
	23.3 Employee Claims.....	113
	23.4 No Relief from Responsibility.....	113
	23.5 Right to Rely	113
	23.6 Survival.....	113
	23.7 Intent of Indemnity for Breach of Contract	113
24.	TORT LIABILITY	114
	24.1 Notice of Claims	114
	24.2 Limitation on Mobility Authority’s Liability	114
25.	DISPUTE RESOLUTION	114
	25.1 General Dispute Resolution Provisions	114
	25.2 Purpose.....	115
	25.3 Disputes Board Membership.....	115
	25.4 Disputes Board Operations	117
	25.5 Schedule for Dispute Resolution	119
	25.6 Hearing.....	122

Table of Contents

25.7	Compensation	123
25.8	Cooperation.....	124
25.9	Provisional Remedies.....	124
25.10	Participation in Other Proceedings	124
25.11	Governing Law	124
26.	DOCUMENTS AND RECORDS.....	124
26.1	Escrowed Proposal Documents.....	124
26.2	Subcontract Pricing Documents.....	126
26.3	Reporting Requirements	126
26.4	Maintenance of, Access to, and Audit of Records.....	127
26.5	Retention of Records.....	128
26.6	Public Records Act	129
27.	COOPERATION AND COORDINATION WITH OTHER CONTRACTORS AND GOVERNMENTAL ENTITIES.....	129
27.1	Cooperation with Other Contractors.....	129
27.2	Interference by Other Contractors	129
27.3	Coordination with Governmental Entities and Contractors.....	130
27.4	Coordination with Toll Related Project Participants; System Integrator; Delays ...	130
28.	GOVERNING LAW, COMPLIANCE WITH LAW, AND REFERENCE STANDARDS	130
28.1	Texas Law	130
28.2	Compliance with Laws and Federal Requirements	130
28.3	Compliance with Referenced Standards	131
29.	MISCELLANEOUS	131
29.1	Reserved Rights	131
29.2	Ownership of Documents	131
29.3	Amendments to Contract Documents	131
29.4	Waiver.....	132
29.5	Relationship of Parties	132
29.6	Assignment	132
29.7	Designation of Representatives; Cooperation with Representatives and with Financing Entities.....	133
29.8	No Gift or Dedication	133
29.9	Use of Police and Other Powers	134
29.10	Survival	134
29.11	No Third Party Beneficiaries	134
29.12	Notices and Communications	134
29.13	Further Assurances.....	136
29.14	Severability	136
29.15	Headings	136
29.16	Interpretation of Contract Documents	136
29.17	Approvals under Contract Documents.....	137
29.18	Counterparts and Electronic Signature	137

Table of Contents

29.19 Non-Business Days.....137
29.20 Entire Agreement.....138
29.21 Monetary Obligations Subject to Appropriation.....138

Table of Contents

EXHIBITS

EXHIBIT A	Abbreviations and Definitions
EXHIBIT B	Scope of Work
EXHIBIT C	Technical Provisions
EXHIBIT D	Reference Documents
EXHIBIT E	Federal Requirements
EXHIBIT F	Amendments, Modifications and Supplements to TxDOT Standard Specifications
EXHIBIT G	Payment Curve
EXHIBIT H	CTRMA DBE Policy Statement
EXHIBIT I	Form of Performance Bond
EXHIBIT J	Form of Payment Bond
EXHIBIT K	Form of Warranty Bond
EXHIBIT L	Draw Request and Certificates
EXHIBIT M	Form of Change Order Form
EXHIBIT N	Initial Designation of Authorized Representatives
EXHIBIT O	DB Contractor Commitments and ATCs
EXHIBIT P	Debarment Certificate
EXHIBIT Q	Noncompliance Charges Provisions

**DESIGN-BUILD AGREEMENT
(183 North Mobility Project)**

This **DESIGN-BUILD AGREEMENT ("DB Agreement")** is made and entered into as of _____ 2021, by and between the **CENTRAL TEXAS REGIONAL MOBILITY AUTHORITY** (the "**Mobility Authority**"), a regional mobility authority created by Travis and Williamson Counties located in central Texas and operating pursuant to Chapter 370 of the Texas Transportation Code, and **GREAT HILLS CONSTRUCTORS**, a joint venture between Archer Western Construction, LLC and Sundt Construction, Inc. (the "**DB Contractor**"), with reference to the following facts:

A. The Mobility Authority desires to develop as a toll road a portion of existing US 183 extending for approximately nine miles from State Highway (SH 45) North/Ranch-to-Market (RM) 620 to State Loop 1 (MoPac) and generally consisting of the construction of four express lanes (two in each direction) and widening of the existing United States Highway (US) 183 as required to bring the total number of general purpose lanes to four in each direction, in addition to other improvements, as more specifically described in the Scope of Work (*Exhibit B*) and Technical Provisions (*Exhibit C*), are the "**Project**").

B. The Mobility Authority has determined that it is in the best interests of the Mobility Authority and the public to contract with a single entity to develop, design and construct the Project.

C. Pursuant to Chapter 370 of the Texas Transportation Code (the "**Act**"), 43 Tex. Admin. Code, Chapter 26 (the "**Rules**"), and the Mobility Authority's Policies and Procedures Governing Procurement of Goods and Services ("**Mobility Authority Procurement Policies**"), the Mobility Authority issued a Request for Qualifications on March 15, 2019 (the "**RFQ**"). The RFQ was supplemented by information posted on the Mobility Authority website.

D. On May 24, 2019, the Mobility Authority received responses to the RFQ from prospective DB Contractors.

E. On July 24, 2019, the Mobility Authority's Board of Directors (the "**Board**"), in accordance with the recommendation of an RFQ evaluation committee, shortlisted prospective DB Contractors based upon their responses to the RFQ.

F. On November 20, 2019, pursuant to the Act, the Rules, and the Mobility Authority Procurement Policies, the Mobility Authority issued a final Request for Detailed Proposals ("**RFDP**") to the prospective DB Contractors shortlisted by the Board. Addendum No. 1 to the RFDP was issued on January 7, 2020. Addendum No. 2 to the RFDP was issued on March 2, 2020. Addendum No. 2.1 to the RFDP was issued on March 23, 2020. Addendum No. 2.2 to the RFDP was issued on May 14, 2020. Addendum No. 3 to the RFDP was issued on July 1, 2020.

G. The Mobility Authority received three (3) responses to the RFDP on August 18, 2020.

H. After review and analysis and in accordance with applicable law, rules, policies, and the RFDP, an RFDP evaluation committee comprised of Mobility Authority staff and consultants determined that the DB Contractor was the proposer which best met the selection criteria contained

in the RFDP and that its proposal was the one which provided the best value to the Mobility Authority.

I. On February 8, 2021, the Mobility Authority Board accepted the recommendation of the Mobility Authority Acting Director of Engineering and the RFDP evaluation committee and authorized the Mobility Authority staff to negotiate and finalize this DB Agreement.

J. The Interim Executive Director of the Mobility Authority has been authorized to enter into this DB Agreement pursuant to a resolution of the Mobility Authority Board dated January 27, 2021.

K. The DB Contractor's team includes the following Major Participant: Parsons Transportation Group Inc.

L. The Parties intend for this DB Agreement to be a fixed price, lump sum contract obligating the DB Contractor to perform all work necessary to complete the Work by the deadlines set forth in the DB Agreement and in a manner satisfactory to the Mobility Authority, for the Design-Build (DB) Price, subject only to certain specified limited exceptions set forth herein. The DB Contractor submitted with its Proposal a fixed price for the Project, and the Contract Documents provide that the Mobility Authority has no liability for any portion of the Work for which a notice to proceed ("NTP") has not been issued. In order to allow the Mobility Authority to budget for and finance the Project and to reduce the risk of cost overruns, this DB Agreement includes restrictions affecting the DB Contractor's ability to make claims for an increase to the DB Price or an extension of the Completion Deadline or the Acceptance Deadline herein.

M. If the DB Contractor fails to complete the Work within the time limitations set forth in the Contract Documents, then the Mobility Authority will suffer substantial losses and damages which are impracticable and extremely difficult to ascertain. The Contract Documents therefore provide that the DB Contractor shall pay the Mobility Authority substantial Liquidated Damages in the event any such completion is delayed, on the conditions provided herein.

N. The Reference Documents include a Schematic Plan for the design of the Project. The Mobility Authority and the DB Contractor both intend for the DB Contractor to assume full responsibility and liability with respect to development of a Project Design of the Project, including correction of any errors, omissions, inconsistencies or other defects in the Schematic Plan affecting constructability, and for the DB Contractor to indemnify, defend and hold each of the Indemnified Parties harmless with respect to any defects in the Project which may relate to errors, omissions, inconsistencies or other defects in the Schematic Plan.

NOW, THEREFORE, in consideration of the sums to be paid to the DB Contractor by the Mobility Authority, the foregoing promises and the covenants and agreements set forth herein, the Parties hereby agree as follows:

1. CONTRACT COMPONENTS

1.1 Certain Definitions

Initially capitalized terms not otherwise defined in the body of this DB Agreement shall have the definitions set forth in Exhibit A of this DB Agreement.

1.2 Order of Precedence

Each of the Contract Documents is an essential part of this DB Agreement. The Contract Documents are intended to be complementary and to describe and provide for a complete DB Agreement. In the event of any conflict among the Contract Documents or between the Contract Documents and other documents, the order of precedence shall be as set forth below. For design and construction related standards and requirements, the order of precedence shall be:

- (a) Change Orders and DB Agreement amendments;
- (b) This DB Agreement (including Exhibit A but exclusive of other exhibits, unless specifically referred to in the body of the DB Agreement);
- (c) The Proposal, to the extent that it exceeds the requirements of the other Contract Documents. In other words, if the Proposal includes statements that can reasonably be interpreted as offers to provide higher quality items than otherwise required by the Contract Documents or to perform services in addition to those otherwise required, or otherwise contains terms which are more advantageous to the Mobility Authority than the requirements of the other Contract Documents, the DB Contractor's obligations hereunder shall include compliance with all such statements, offers and terms. All such statements, offers and terms are set forth in Exhibit O and are specifically incorporated into this DB Agreement. In no event, unless specifically provided herein, shall the Proposal supercede a higher standard or obligation contained elsewhere in the Contract Documents.
- (d) Scope of Work (Exhibit B to this DB Agreement);
- (e) Technical Provisions, as modified by any ATCs accepted by the Mobility Authority and included in Exhibit O hereto (Exhibit C to this DB Agreement);
- (f) TxDOT Standards and TxDOT Specifications; and
- (g) AASHTO Guidelines.

Certain of the Appendices to Exhibit D which are listed as Reference Documents are referenced in the Contract Documents for the purpose of defining requirements of the Contract Documents. Each such Appendix shall be deemed incorporated in the Contract Documents to the extent that it is so referenced, with the same order of priority as the highest level Contract Document in which the reference occurs. Additional details and more stringent requirements contained in a lower priority document will control unless the requirements of the lower priority document present an actual conflict with the requirements of the higher level document. Notwithstanding the order of precedence among Contract Documents set forth in this Section 1.2, in the event of a conflict within a Contract Document or set of Contract Documents with the same order of priority (including within documents referenced therein), the Mobility Authority shall have the right to determine, in its sole discretion, which provision applies. The DB Contractor shall

request the Mobility Authority's determination respecting the order of precedence among such provisions promptly upon becoming aware of any such conflict.

In the event that the Contract Documents are ambiguous with respect to, or allow more than one choice of, the standard or course of action applicable to the completion of any portion of the Work and the Mobility Authority and the DB Contractor cannot agree as to the appropriate standard or course of action, the Mobility Authority shall, in its reasonable discretion, determine the applicable standard or course of action that best preserves the long term durability, maintainability, and safety of the Project.

1.3 Referenced Standards

1.3.1 Unless otherwise specified by the Mobility Authority, any reference in the Contract Documents to a described publication affecting any portion of the Work shall be deemed to mean the latest edition or revision thereof, and amendments and supplements thereto, in effect on the Proposal Date.

1.3.2 In interpreting Referenced Standards, policies and specifications, the following apply:

- (a) References to the Project owner shall mean the Mobility Authority;
- (b) References to the Engineer in the *TxDOT Standard Specifications for Construction and Maintenance of Highways, Streets, and Bridges*, adopted by TxDOT in November 2014, in the context of provider of compliance judgment, shall mean the Resident Engineer, or other Mobility Authority representative, as determined by the Mobility Authority in its discretion.
- (c) References to "**plan(s)**" shall mean the Design Documents; and
- (d) Cross-references to measurement and payment provisions contained in the Referenced Standards, policies and specifications shall be deemed to refer to the measurement and payment provisions contained in the Contract Documents.

2. GENERAL FRAMEWORK AND OUTLINE OF TRANSACTION

2.1 Type of Transaction

This DB Agreement creates a partnering transaction to develop, design, permit, construct and insure the Project in accordance with the requirements of the Contract Documents.

2.2 Role of Parties to Transaction

2.2.1 DB Contractor's Role

2.2.1.1 Prior to the issuance of NTP1, the DB Contractor may, at its sole option and risk, carry out certain Mobility Authority activities, including assisting and cooperating with the Mobility Authority, as it may request, in connection with the closing of the Project financing, including Bond financing, if any, and applications for State and federal assistance, by providing any reasonably requested information about the DB Contractor's organization and business.

2.2.1.2 From the issuance of NTP1 through Project Final Acceptance, the DB Contractor shall complete and manage the Work at a fixed price (with certain limited exceptions thereto set forth in Section 14 of this DB Agreement) in compliance with the Contract Documents and in accordance with the Project Schedule, including but not limited to:

(a) Preparing or causing to be prepared all plans and specifications in accordance with TxDOT and FHWA approvals and other Governmental Approvals, applicable Law, this DB Agreement and the other Contract Documents, and any amendments thereto;

(b) Acquiring any required the DB Contractor-Designated ROW;

(c) Performing Utility Adjustment Work in accordance with the Contract Documents;

(d) Obtaining (if not previously obtained by the Mobility Authority) and complying with all necessary Governmental Approvals;

(e) Completing the Work in accordance with the Design Documents and the Project Schedule;

(f) Monitoring and ensuring quality completion by all members of the DB Contractor Group of all aspects of the Work;

(g) Providing quality control and material quality assurance with respect to the Work, subject to Mobility Authority quality acceptance, oversight, testing and involvement and directives;

(h) Providing the Payment Bond and the Performance Bond in accordance with this DB Agreement;

(i) Maintaining or causing to be maintained in place insurance policies which satisfy the insurance requirements set forth in this DB Agreement;

(j) Warranting the Work, to the extent required under this DB Agreement;

(k) Continuing to assist and cooperate with the Mobility Authority, as it may request, in connection with the Project financing by providing any reasonably requested information; and

(l) Complying with any requirements of the Mobility Authority applicable to the Project, that are contained in the Project Development Agreement for the 183 North Mobility Project (the "PDA") between the Mobility Authority and TxDOT, a copy of which is contained in Exhibit D – Item 1.3. Such compliance requires assumption of the Mobility Authority obligations under the following sections of the PDA: 5 (design and construction), 6 (control of work), 7 (utility relocations), 9 (maintenance activities), 10 (environmental permits and compliance), 12 (HUB policy and DBE guidelines), 13 (compliance with applicable laws), 15 (maintenance of records), and 23 (debarment requirements).

2.2.2 Mobility Authority's Role

2.2.2.1 Prior to the issuance of NTP2, the Mobility Authority shall have the right to carry out certain financing-related and pre-construction activities, including:

- (a) Participating in the negotiation of, and approving, the terms and conditions for the financing of the Project;
- (b) Acquiring the Schematic ROW; and
- (c) Taking all necessary action to advance the Project including working with the DB Contractor in dealing with Governmental Entities, railroads, Utilities, and other interested parties to obtain necessary permits and agreements.

2.2.2.2 From the date on which the Mobility Authority issues NTP1 through Project Final Acceptance, the Mobility Authority shall carry out certain design and construction-related activities, including:

- (a) Undertaking and/or completing any of the activities set forth in Section 2.2.2.1 that are not completed as of the date on which the Mobility Authority issues NTP1;
- (b) Overseeing the completion of the Work in accordance with this DB Agreement;
- (c) Performing design quality acceptance and certain construction quality acceptance, testing and oversight services in connection with the Work;
- (d) Applying proceeds of Project financing toward, among other things, the payments under this DB Agreement;
- (e) Acknowledging the occurrence of Substantial Completion and Final Acceptance;
- (f) Performing quarterly audit of processes, procedures and files to ensure compliance with the Uniform Act and State laws, rules and regulations; and
- (g) Administering this DB Agreement.

2.2.2.3 From and after the commencement of tolling operations of the Project following Substantial Completion, the Mobility Authority shall have the right to carry out certain operations activities, including:

- (a) Imposing tolls and fixing toll rates for use of the Project;
- (b) Applying toll revenues to the purposes and in the priority permitted under Law;
- (c) Administering this DB Agreement; and
- (d) Enforcing the Warranties and any other Project warranties and guarantees.

2.3 Partnering

2.3.1 Purpose; Scope

The Mobility Authority intends to encourage the foundation of a cohesive partner relationship with the DB Contractor and its Subcontractors. The objectives include effective and efficient performance and completion of the Work within budget, in accordance with the Project Schedule, and in accordance with the Contract Documents. An integral aspect of the partnering is the resolution of issues in a timely, professional and non-adversarial manner. The parties acknowledge that one of the keys to the success of these major projects is to build trust between the parties through communication and understanding. It is the Mobility Authority's belief that a strong partnering program will assist in promoting and maintaining an amicable working relationship.

2.3.2 Schedule; Participation

Pursuant to *Technical Provision 1*, within 30 Days after issuance of NTP1, the DB Contractor and the Mobility Authority jointly shall agree upon and select a third-party facilitator to conduct the partnering meetings. The cost of the facilitator shall be shared equally between the Mobility Authority and the DB Contractor. All costs of providing the partnering workshops, other than the cost of the partnering facilitator, shall be paid by the DB Contractor. Partnering meetings may be conducted at the office of the Mobility Authority or at such location as otherwise agreed upon by the Parties. Persons who should attend the partnering meetings include Key Personnel and executives of the Parties.

2.3.3 Use of Information From Partnering Meetings

Subject to the requirements of the Public Information Act, no statements made or materials prepared during or relating to partnering meetings, including any statements made or documents prepared by the facilitator, shall be admissible or discoverable in any judicial or other dispute resolution proceeding.

3. SCOPE OF WORK; ROLE OF THE PARTIES AND LOCAL AGENCIES; EFFECT OF TESTS AND INSPECTIONS

3.1 Work Scope

The Work includes the DB Contractor's obligation to furnish a complete design for the Project meeting all requirements of the Contract Documents, to construct the Project as designed and in accordance with all requirements of the Contract Documents and otherwise to comply with all of the requirements in this DB Agreement. The DB Contractor acknowledges that the Mobility Authority's designs of certain Project elements have been advanced to different stages of development and are generally conceptual in nature and complete enough to support the Environmental Documents. The Reference Documents are provided as guidelines and programs to assist the DB Contractor in performing the Work. The DB Contractor acknowledges that the DB Contractor is not entitled to rely on and has not relied on (i) the Reference Documents or (ii) any other documents or information provided by the Mobility Authority, except to the extent specifically permitted in the Contract Documents.

3.2 Project Location and Description

A general description of the Project is set forth in the Scope of Work (Exhibit B).

3.3 Project Management Plan

The DB Contractor shall plan, schedule, and execute all aspects of the Work and shall coordinate its activities with all parties who are directly impacted by the Work. The DB Contractor shall document and report all Work in accordance with the requirements set forth herein and in an approved Project Management Plan. Within 30 Days after the issuance of NTP1, The DB Contractor shall submit the detailed Project Management Plan, which shall update and expand the project management plan contained in the DB Contractor's Proposal to meet the requirements contained in Technical Provisions 1 and 2, to the Mobility Authority for acceptance.

3.4 Mobility Authority's Role

The Mobility Authority, or its designee, intends to oversee performance of the Work for the purpose of confirming that the Work meets the requirements of the Contract Documents. Mobility Authority responsibilities include design reviews and acceptance, construction inspection and acceptance, oversight of materials, acceptance of the Work in accordance with Section 20, and establishment of priorities for the purpose of ensuring timely receipt of revenues. The Mobility Authority's role in oversight of the DB Contractor's design and construction quality is detailed in Technical Provision 2. The Mobility Authority will also serve as a liaison with regulatory agencies in connection with the DB Contractor's application for Environmental Approvals and/or amendments or re-evaluations for which the DB Contractor is responsible, provided that the ultimate responsibility for obtaining such Environmental Approvals shall remain with the DB Contractor and the DB Contractor shall not be entitled to a Change Order for additional time or compensation due to any action or inaction of the Mobility Authority with respect to such liaison service. The Mobility Authority will provide the Mobility Authority-Provided Approvals in accordance with the Contract Documents. The Mobility Authority will assist the DB Contractor in efforts to obtain any required TxDOT and FHWA approvals, provided that the ultimate responsibility for such reviews and approvals shall remain with the DB Contractor and the DB Contractor shall not be entitled to a Change Order for additional time or compensation due to any action or inaction by the Mobility Authority related to such assistance. The Mobility Authority, or its designee, will also administer this DB Agreement, including: review and approval of progress payments; Project Schedule review and approval; performance evaluation; Change Order negotiation; and dispute resolution. The Mobility Authority will designate a Resident Engineer to assist the Mobility Authority with the administration and oversight of the Work. The Resident Engineer is not authorized to waive any requirements or provisions of this DB Agreement.

3.5 Local Agencies' Roles

Elements of the Work on local roads may be subject to review, approval, inspection, testing, and/or acceptance by local agencies. In addition, certain environmental mitigation measures identified in the Environmental Documents may require coordination with local agencies. The DB Contractor shall take such actions as are necessary to obtain all needed local Governmental Approvals and ensure coordination with local agencies, in each case, as required to undertake and complete the Work, but the DB Contractor shall not make any commitment or enter

into any obligations that will affect or impact the Mobility Authority or TxDOT without the written consent of the Mobility Authority and/or TxDOT, as the case may be.

3.6 DB Contractor Obligations

3.6.1 The DB Contractor shall design and construct the Project in conformity with the Basic Configuration and in general conformity with the Schematic Plan, in accordance with all professional engineering principles and construction practices generally accepted in the State as the standard in the industry. The DB Contractor shall construct the Project in a good and workmanlike manner, free from defects and in accordance with the terms and conditions set forth in the Contract Documents. Except as otherwise specifically provided in the Contract Documents, all materials, services and efforts necessary to achieve Substantial Completion on or before the Completion Deadline and Final Acceptance on or before the Acceptance Deadline shall be the DB Contractor's sole responsibility; and the cost of all such materials, services and efforts are included in the DB Price. The DB Contractor acknowledges that it shall maintain the Work until Final Acceptance, including repair of damage caused by accidents or vandalism, and that the cost of maintenance services for the Project prior to Final Acceptance is included in the DB Price except as otherwise specified in the Contract Documents.

3.6.2 The DB Contractor shall furnish all design and other services, provide all supervision, labor, equipment and materials and undertake all efforts necessary or appropriate (excluding only those materials, services and efforts which the Contract Documents specify will be undertaken by other Persons) to construct the Project, achieve Substantial Completion on or before the Completion Deadline and Final Acceptance on or before the Acceptance Deadline and maintain the Work during construction. In so doing, the DB Contractor shall comply with the requirements of the Contract Documents, the Project Schedule, all Governmental Approvals, the approved Project Management Plan, the approved Design Quality Management Plan (“**DQMP**”), the approved Construction Quality Management Plan (“**CQMP**”), the Mobility Authority’s Quality Assurance Program (“**QAP**”), the approved Safety Plan and applicable Laws, and shall take into account the boundaries of the Schematic ROW, the Additional Properties and other physical constraints affecting the Project. Unless Utilities are relocated at the expense of a Utility Owner or a local government, the DB Contractor shall be responsible for reimbursing any railroad and Utility Owners for Adjustments that they perform. The DB Contractor shall also be responsible for coordinating construction and other activities with any railroad and Utility Owners and other contractors involved with the Project, and/or projects adjacent to the Project in order to ensure that the Project is able to open to the public and commence toll revenue service on or before the Completion Deadline.

3.6.3 The DB Contractor shall, at all times, provide a Project Manager approved in writing by the Mobility Authority, in its sole discretion, who will have full responsibility for the prosecution of the Work and will act as a single point of contact in all matters on behalf of the DB Contractor. The DB Contractor shall not change the Project Manager or any other Category A Personnel, as described in *Technical Provision 1*, except for the reasons specified in *Section 19.1.6*, without the prior written approval of the Mobility Authority, in its sole discretion. If the DB Contractor fails to obtain the Mobility Authority’s approval of a replacement within 30 Days after the existing Project Manager or Category A Person leaves, the Mobility Authority shall have the right to apply the provisions of *Section 19.1* until such time as an approved replacement has started work. Moreover, the DB Contractor shall not change or replace any Major Participant without the

prior written approval of the Mobility Authority, and the Mobility Authority may apply the provisions of Section 19.1 until such time as a replacement Major Participant has been approved by the Mobility Authority.

3.6.4 The DB Contractor shall obtain and pay the cost of obtaining all Governmental Approvals except Mobility Authority-Provided Approvals. Prior to beginning any construction activities for any portion of the Project, the DB Contractor shall furnish the Mobility Authority with fully executed copies of all Governmental Approvals required for such portion of the Project and provide the Mobility Authority with all bonds required under this DB Agreement.

3.6.5 Except as provided in Sections 7.5.2 and 7.6, the DB Contractor shall, at its expense, undertake and properly perform all actions required by, and all actions necessary to maintain in full force and effect, all Governmental Approvals, including performance of all environmental mitigation and compliance measures required by the Contract Documents, Environmental Approvals and applicable Law.

3.6.6 The DB Contractor shall perform construction inspection, material sampling and testing in accordance with the Contract Documents and the DB Contractor's approved CQMP and the Mobility Authority's QAP.

3.6.7 The DB Contractor shall provide and maintain field offices as described in Technical Provision 1, which facilities shall be for the joint use of the DB Contractor, the Mobility Authority, the Resident Engineer and other Persons reasonably designated by the Mobility Authority.

3.6.8 The DB Contractor shall cooperate with the Mobility Authority and its agents and designated representatives in connection with all matters relating to the Project, including review of the design of the Project and conducting inspections during the construction of the Project.

3.6.9 The DB Contractor shall mitigate delay to the Project and mitigate damages due to delay in all circumstances, at no cost to the Mobility Authority except as otherwise specified herein, to the extent reasonably possible, including by resequencing, reallocating or redeploying its forces to other work, and obtaining additional personnel, equipment and materials, as necessary.

3.6.10 The DB Contractor shall, at all times, deliver design submittals in accordance with the Technical Provisions. The DB Contractor shall deliver to the Mobility Authority a written certification by the Design Quality Assurance Manager ("DQAM") of the Final Design Plans for the Project in accordance with Technical Provision 2. If the DB Contractor fails to deliver such certification and approval to the Mobility Authority in accordance with the provisions of Technical Provision 2, the Mobility Authority shall have the right to withhold payments under this DB Agreement until such time as the Final Design Plans have been approved by the DQAM and the Mobility Authority, in its design quality acceptance role, in accordance with Technical Provision 2.

3.6.11 The DB Contractor shall, at the completion of the Project, submit to the Mobility Authority in electronic form the as-built plans, signed, sealed, and dated by a professional engineer, licensed in the State of Texas, certifying that the 183 North Mobility Project was constructed in accordance with the approved plans, specifications, and approved contract revisions.

3.6.12 The DB Contractor shall, at its expense, provide for acquisition and relocation services to implement the acquisition of any the DB Contractor-Designated ROW, including the actual real property cost.

3.7 Effect of Reviews, Inspections, Tests, and Acceptances

The DB Contractor shall not be relieved of any obligations to perform the Work in accordance with the Contract Documents by reviews, tests, inspections or acceptances performed by any Persons, or by any failure of any Person to take such action. The reviews, inspections, tests and acceptances conducted or provided by the Mobility Authority and others do not constitute approval of the materials or Work reviewed, tested or inspected, and the Mobility Authority may reject or accept any Work or materials, request modifications or corrective actions, and/or identify additional Work which must be done to bring the Project into compliance with the requirements of the Contract Documents at any time prior to Project Final Acceptance, whether or not previous reviews, inspections, tests or acceptances were conducted by any such Persons; provided that Mobility Authority may not require the DB Contractor to change Work to comply with requirements of the Contract Documents if Mobility Authority has previously approved a specific Deviation from such requirements in writing. Notwithstanding any design oversight, construction oversight, environmental oversight or other Project oversight activities by the Mobility Authority or any of the Indemnified Parties, the DQAM, the Materials Quality Acceptance Manager (“MQAM”), or the Resident Engineer, the DB Contractor shall be solely responsible for the quality, safety and operability of the Project, through its compliance with the requirements of the Contract Documents, the Governmental Approvals and applicable Law.

4. INFORMATION SUPPLIED TO THE DB CONTRACTOR; ACKNOWLEDGMENT BY THE DB CONTRACTOR

4.1 Information Supplied

Exhibit D to this DB Agreement contains the list of Reference Documents that have been made available to the DB Contractor, and the DB Contractor acknowledges and agrees that it has been provided the opportunity to review all such documents.

4.2 Acknowledgment by the DB Contractor

The DB Contractor agrees that it has full responsibility for the design of the Project and that the DB Contractor will furnish the design of the Project regardless of the fact that certain conceptual design work occurred and was provided to the DB Contractor prior to the Effective Date. The DB Contractor agrees that it has diligently reviewed and verified the Schematic Plan for errors, inadequacies, inaccuracies, omissions, inconsistencies or other defects which may affect constructability, durability, conformance with acceptable design standards and efficient and safe operation and has incorporated into the DB Price all costs associated with Work to correct said errors, inadequacies, inaccuracies, omissions, inconsistencies and other defects. The DB Contractor specifically acknowledges and agrees that:

- (a) The Schematic Plan is preliminary and conceptual in nature.
- (b) The DB Contractor is not entitled to rely on any documents or information provided by the Mobility Authority, including the RFDP Documents and the Reference

Documents, except for overall conceptual guidance and then only to the extent expressly provided to the contrary herein.

(c) Subject to the oversight rights of the Mobility Authority under this DB Agreement, the DB Contractor shall correct any errors, inadequacies, inaccuracies, omissions and defects in the Schematic Plan which can be corrected through the design and/or construction process and implement field changes serving the same purpose so long as such correction does not result in a material change in the Basic Configuration.

(d) The Mobility Authority shall have no liability for errors, inadequacies, inaccuracies, omissions and defects in the Schematic Plan. The foregoing shall not be deemed to limit the Mobility Authority's obligations with respect to Differing Site Conditions as set forth in Section 14.9, or the DB Contractor's right to receive any available insurance proceeds.

(e) The Warranties and indemnities hereunder given by the DB Contractor cover errors, omissions and defects in the Project, including those that may be related to errors, inadequacies, inaccuracies, omissions and defects in the Schematic Plan.

(f) Except as may be otherwise provided in Exhibit O, the DB Contractor has independently determined that the Schematic Plan represents a feasible concept for the design of the Project which can and shall be used as the basis for the Project Design to be furnished by the DB Contractor, and agrees that it shall have no right to seek additional compensation or a time extension as a result of errors, omissions, inadequacies or inaccuracies in the Schematic Plan, except as specifically permitted by Section 14.

(g) THE MOBILITY AUTHORITY DOES NOT REPRESENT OR WARRANT THAT THE INFORMATION CONTAINED IN THE SCHEMATIC PLAN, AND OTHER REFERENCE DOCUMENTS IS EITHER COMPLETE, CORRECT OR ACCURATE OR THAT SUCH INFORMATION IS IN CONFORMITY WITH THE REQUIREMENTS OF THE ENVIRONMENTAL APPROVALS, APPLICABLE LAW OR OTHER CONTRACT DOCUMENTS. THE DB CONTRACTOR SHALL BE SOLELY RESPONSIBLE FOR VERIFYING THE ACCURACY AND COMPLETENESS OF SUCH INFORMATION AND SHALL HAVE NO RECOURSE AGAINST THE MOBILITY AUTHORITY OR ITS AGENTS OR REPRESENTATIVES IF SUCH INFORMATION AND/OR ANY ASPECT OF THE SCHEMATIC PLAN OR OTHER REFERENCE DOCUMENTS PROVES TO BE INACCURATE, INCOMPLETE OR NOT IN CONFORMITY WITH THE ENVIRONMENTAL APPROVALS, APPLICABLE LAW OR OTHER CONTRACT DOCUMENTS.

(h) The Mobility Authority shall not be responsible or liable in any respect for any Loss suffered by any member of the DB Contractor Group by reason of any use of any information contained in the Schematic Plan or any action or forbearance in reliance thereon. The DB Contractor further acknowledges and agrees that (i) if, and to the extent that any member of the DB Contractor Group uses any of said information in any way, such use is made on the basis that the DB Contractor, not the Mobility Authority, has approved of such use and information and is responsible for said information, (ii) the DB Contractor is capable of conducting and is obligated hereunder to conduct any and all studies, analyses and investigations as it deems advisable to verify or supplement said information, and (iii) any use of said information is entirely at the DB Contractor's own risk and at its own discretion.

(i) The Schematic Plan is hereby incorporated by reference herein to the extent, and only to the extent, that it sets forth the Basic Configuration of the design of the Project. Accordingly, in general, the DB Contractor may deviate from the Schematic Plan as it deems advisable, provided that it must obtain prior written approval by the Mobility Authority and/or a Change Order hereunder with respect to any material change by the DB Contractor from the Basic Configuration, except as may be otherwise provided in Exhibit O. Furthermore, the DB Contractor's right to deviate from the Schematic Plan and the Basic Configuration is subject to the DB Contractor's compliance with all applicable requirements of the Contract Documents.

(j) The topography mapping, Utility characteristics (including ownership, types, sizes and locations) and the exploratory geotechnical investigations presented in the Reference Documents may or may not represent the actual subsurface conditions along the present alignment of the Project. Except to the extent that Section 14 provides for an increase in the DB Price and/or extensions of the Completion Deadline and/or Acceptance Deadline with respect to such matter, the Mobility Authority accepts no responsibility for the accuracy of the topographical mapping, Utility information or geotechnical information provided, or for information concerning the location or extent of Hazardous Materials, archaeological features, endangered species or vegetation or the DB Contractor's interpretation of any information provided. Furthermore, the DB Contractor acknowledges and agrees that the existing surface conditions, including Utility characteristics as specified above, may have changed or may be different from the surface conditions depicted in the Reference Documents. Except to the extent, if any, that Section 14 provides for an increase in the DB Price and/or extensions of the Completion Deadline and/or Acceptance Deadline with respect to such matter, the Mobility Authority accepts no responsibility for the accuracy of any depiction of surface or subsurface conditions in the Reference Documents or the DB Contractor's interpretation of any information provided.

(k) The Proposal, to the extent that it meets or exceeds the requirements of the other Contract Documents, as provided in Section 1.2(c) hereof, imposes obligations on the DB Contractor hereunder, provided such Proposal shall not supercede a higher standard or obligation contained elsewhere in the Contract Documents.

(l) The DB Contractor is obligated to comply with any TxDOT approval or other TxDOT requirements applicable to the Project, the Mobility Authority, or the DB Contractor contained in or required by the PDA, as specified in Section 2.2.1.1(l) hereof.

4.3 Changes in Basic Configuration

4.3.1 Except as may be otherwise provided in Exhibit O, the DB Contractor shall not make any material change in the Basic Configuration except as approved by the Mobility Authority (with concurrence by TxDOT and FHWA) and authorized by a Change Order. Except as set forth in Section 4.3.3, a Change Order is required regardless of the reason underlying the change and regardless of whether the change increases, decreases or has no effect on the DB Contractor's costs. Any such Change Order shall be subject to the conditions and requirements contained in this Section 4.3, as well as the conditions and requirements which are generally applicable to Change Orders in Section 14 and subject to the limitations contained in Section 7.6.

4.3.2 The DB Contractor shall be responsible for any cost increases and/or delays which affect the duration of a Critical Path activity resulting from changes in requirements and

obligations of the DB Contractor relating to the Project due to inaccuracies in the Schematic Plan. Any changes in the Basic Configuration shall be the responsibility of the DB Contractor with the exception of a Mobility Authority-Directed Change involving more than \$50,000 in additional costs or involving a delay to a Critical Path.

4.3.3 No Change Order shall be required for any non-material changes in the Basic Configuration which have been approved by the Mobility Authority, in writing. The DB Contractor acknowledges and agrees that constraints set forth in the Mobility Authority-Provided Approvals, TxDOT Standards and TxDOT Specifications and other Contract Documents, as well as site conditions and the Schematic Plan, will impact the DB Contractor's ability to make changes in the Basic Configuration.

5. TIME WITHIN WHICH PROJECT SHALL BE COMPLETED; PROJECT SCHEDULE AND PROGRESS

5.1 Time of Essence; Notices to Proceed

5.1.1 As a material consideration for entering into the DB Agreement, the DB Contractor hereby commits, and the Mobility Authority is relying upon the DB Contractor's commitment, to develop the Project in accordance with the time periods set forth in this DB Agreement. Except where this DB Agreement expressly provides for an extension of time, the time limitation set forth in the Contract Documents for the DB Contractor's performance of its covenants, conditions and obligations are of the essence, and the DB Contractor waives any right at law or in equity to tender or complete performance beyond the applicable time period, or to require the Mobility Authority to accept such performance.

5.1.2 Authorization allowing the DB Contractor to proceed with Work hereunder shall be provided through the Mobility Authority's issuance of NTP1 and NTP2.

5.1.3 The Mobility Authority anticipates issuing NTP1 following the Finance Closing Date. Issuance of NTP1 authorizes the DB Contractor to perform the portion of the Work necessary to obtain the Mobility Authority's acceptance of the component parts, plans and documentation of the PMP and QMP, to enter the Project ROW in order to conduct surveys and site investigations, including geotechnical, Hazardous Materials and Utilities investigations, and to begin negotiating Utility agreements. It also authorizes the DB Contractor to commence Design Work in accordance with the Technical Provisions, provided however that the Design Work may not commence until after submittal and acceptance of the PMP and DQMP.

5.1.4 The Mobility Authority anticipates issuing NTP2 and NTP3 following the Finance Closing Date. Issuance of NTP2 authorizes the DB Contractor to perform all other Base Scope Work and activities pertaining to the Project. Issuance of NTP3 authorizes the DB Contractor to commence the Deferred Work. Notwithstanding issuance of NTP2, the DB Contractor shall not be permitted to commence Construction Work on any portion of the Project until all the conditions to the commencement of Construction Work set forth in Section 7.1 have been satisfied.

5.2 Guaranteed Completion

5.2.1 Completion Deadline

5.2.1.1 Subject to the adjustments of the Completion Deadline and Acceptance Deadline as provided in the Contract Documents, the DB Contractor shall achieve Substantial Completion of the Project no later than **1,519** Days after the issuance of NTP1. If the Mobility Authority elects to issue NTP3 for the Deferred Work, then the DB Contractor shall achieve Substantial Completion of the Project no later than **1,519** Days after the issuance of NTP1.

5.2.1.2 The deadline for Substantial Completion set forth above, as it may be extended hereunder, is referred to herein as the "**Completion Deadline.**"

5.2.2 Acceptance Deadline

The DB Contractor shall achieve Final Acceptance of the Project within 120 Days after Substantial Completion of the Project. The deadline for Final Acceptance of the Project, as such deadline may be extended hereunder, is referred to herein as the "**Acceptance Deadline.**"

5.2.3 No Time Extensions

Except as otherwise specifically provided in *Section 14*, the Mobility Authority shall have no obligation to extend the Completion Deadline or Acceptance Deadline, and the DB Contractor shall not be relieved of its obligations to achieve (a) the milestones described in the Project Schedule; (b) Substantial Completion of the Project by the Completion Deadline; or (c) Final Acceptance by the Acceptance Deadline.

5.3 Project Schedule

The planning, design, construction, and completion of the Work shall be undertaken and completed in accordance with the Project Schedule approved by the Mobility Authority in writing, as revised and updated from time to time. The Project Schedule shall be used by the Parties for planning and monitoring the progress of the Work and as the basis for determining the amount of monthly progress payments to be made to the DB Contractor.

5.4 Project Schedule Submittals

The DB Contractor shall deliver the Project Schedule submittals described in *Technical Provision 5*.

5.5 Recovery Schedule

5.5.1 In accordance with Technical Provision 5, a Recovery Schedule is required at the request of the Mobility Authority, whenever the DB Contractor's Work is delayed on any Critical Path deadline date for a period which exceeds the lesser of (a) 30 Days in the aggregate or (b) that number of Days which, in the aggregate, is equal to 5% of the Days remaining until the Completion Deadline for the Project, excluding Mobility Authority-Caused Delays and any other delays for which the DB Contractor is entitled to seek an extension.¹ In such event, the DB Contractor shall include, as part of the next Monthly Update revision submittal, a Recovery Schedule demonstrating the DB Contractor's program and proposed plan to address Project Schedule delays in order to achieve Substantial Completion of the Project by the Completion Deadline and Final Acceptance of the Project by the Acceptance Deadline.

5.5.2 All costs incurred by the DB Contractor in preparing and implementing the Recovery Schedule shall be borne by the DB Contractor and shall not result in a change to the DB Price, except to the extent permitted in accordance with Section 14 or Section 5.5.3.

5.5.3 If a Recovery Schedule would be required in order to achieve Substantial Completion of the Project by the Completion Deadline as the result of an event described in Section 14 and the DB Contractor would be entitled under this DB Agreement to an increase in the DB Price to implement such Recovery Schedule, the Mobility Authority shall have the right, in its sole discretion, to decide whether to allow a time extension or to require implementation of the Recovery Schedule without such time extension, provided that provision by the DB Contractor of such a Recovery Schedule is commercially reasonable. In such event, the DB Contractor shall submit to the Mobility Authority at least two alternative Change Order forms, one of which shall include a Recovery Schedule and show the proposed Acceleration Costs associated with the Recovery Schedule, and the other of which shall provide for an extension of the Completion Deadline without any increase in the DB Price (except as provided in Section 14). If the Mobility Authority elects to implement the Recovery Schedule in lieu of a time extension, the Mobility Authority shall issue a Change Order increasing the DB Price to account for and include the additional Acceleration Costs. If it is not feasible to regain the time lost under the Project Schedule so as to meet the Completion Deadline or if the DB Contractor believes that the Acceleration Costs associated with such a recovery are prohibitive, then the DB Contractor shall recommend a time extension in the Change Order form.

5.5.4 If a Recovery Schedule is required hereunder, the DB Contractor shall provide such Recovery Schedule in writing within ten (10) Business Days of Mobility Authority's request.

5.5.5 Notwithstanding anything in the Contract Documents to the contrary, there shall be no Event of Default for the DB Contractor's unexcused delay in achieving the Completion Deadline or Acceptance Deadline by the dates allowed under the Contract Documents or the DB Contractor's provision of a schedule showing an unexcused delay in achieving any such deadlines so long as (i) such delay is no greater than 180 Days and (ii) notwithstanding the liability cap contained in Section 18.3 hereof, the DB Contractor pays Liquidated Damages to the Mobility

(1) For example, if there are 80 Days remaining to the Completion Deadline for the Project, 5% of that number would be 4 Days. In that case, the DB Contractor would be obligated to provide a Recovery Schedule if the DB Contractor was behind schedule by more than 4 Days.

Authority for each Day of actual delay beyond the applicable completion or Acceptance Deadline. Notwithstanding any approval rights that the Mobility Authority may have concerning a Recovery Schedule or anything else in the Contract Documents to the contrary, the amount of schedule recovery and the DB Contractor's means and methods of schedule recovery, shall be in the DB Contractor's discretion so long as the DB Contractor's unexcused delay meets the requirements set forth in the preceding sentence.

5.6 Float

All Float contained in the Project Schedule shall be considered a Project resource available to either Party or both Parties, on an as-needed basis, to achieve Project Schedule milestones, Substantial Completion by the Completion Deadline and/or Final Acceptance by the Acceptance Deadline. All Float shall be shown in the Project Schedule on each Project Schedule submittal. Identification of (or failure to identify) Float on the schedule shall be evaluated by the Mobility Authority in determining whether to approve the Project Schedule. Once identified, Float shall be monitored, accounted for and maintained in accordance with critical path methodology.

6. RIGHT OF WAY SERVICES

6.1 Acquisition of Final ROW

Acquisition of Final ROW shall be undertaken and completed in accordance with the requirements and obligations of this Section 6 and Technical Provision 7.

6.2 Costs of Acquisitions

6.2.1 The parties hereto acknowledge that, as between the Mobility Authority and the DB Contractor, Mobility Authority shall be responsible for the purchase price for (i) all parcels, exclusive of Existing Utility Property Interests, within the Schematic ROW, and (ii) any real property outside of the Schematic ROW that must be acquired due to a Mobility Authority-Directed Change, and shall be responsible for all right of way engineering, administration, acquisition and related services for all such parcels, including all costs and expenses of negotiation and condemnation proceedings. Only TxDOT or the Mobility Authority may initiate condemnation proceedings.

6.2.2 The DB Contractor shall be responsible for all costs and expenses of performing the right of way services described in Technical Provision 7 in connection with acquiring all DB Contractor-Designated ROW, Existing Utility Property Interests and New Utility Property Interests including the purchase price, and all costs and expenses of obtaining necessary Environmental Approvals, right of way engineering, administration, acquisition and related services. The DB Contractor shall pay all costs and expenses of the DB Contractor and all reasonable costs and expenses of the Mobility Authority (and TxDOT, if applicable) in connection therewith, whether the acquisition is by negotiation or condemnation, including the reasonable costs for private counsel retained by the Mobility Authority (or TxDOT) for such purposes. If the Mobility Authority (or TxDOT) incurs any such costs and expenses on the DB Contractor's behalf, the Mobility Authority (or TxDOT) may submit any invoices for such costs and expenses to the DB Contractor, in which case the DB Contractor shall pay the invoices prior to delinquency. If the Mobility Authority (or TxDOT) pays any such costs and expenses on the DB Contractor's behalf, the DB Contractor shall reimburse the Mobility Authority (or TxDOT, as applicable) within

10 Days of the submittal to the DB Contractor of an invoice for such costs and expenses. Alternatively, the Mobility Authority may deduct the amount of such costs and expenses from any sums owed by the Mobility Authority to the DB Contractor pursuant to this DB Agreement.

6.2.3 All costs and expenses for the acquisition of any temporary right or interest in real property that the DB Contractor determines necessary or desirable for its convenience in constructing the Project, such as for work space, laydown areas, materials storage areas or temporary utility relocation, or for any permanent interest in real property that the DB Contractor may wish to acquire for its convenience which will not be part of the Final ROW, shall be the DB Contractor's sole responsibility, to be undertaken at the DB Contractor's sole cost and expense. The Mobility Authority shall have no obligations or responsibilities with respect to the acquisition, maintenance or disposition of such rights or interests, and is not required to use its powers of eminent domain in connection therewith. The DB Contractor will comply with all applicable Laws in acquiring and maintaining or disposing of any such property rights or interests. The DB Contractor shall cause the documentation of any such property interest to contain the grantor's express acknowledgment that the Mobility Authority shall have no liability with respect thereto.

6.2.4 The DB Contractor shall be responsible for all costs and expenses incurred by Utility Owners in acquiring New Utility Property Interests, excluding any such costs or expenses attributable to any Betterments.

6.3 Limiting Acquisition of Additional Properties

The DB Contractor's recommendation regarding the acquisition of Additional Properties shall be subject to the following:

6.3.1 The DB Contractor shall use its Best Efforts to restrict and limit additional costs to the Project associated with Mobility Authority-Directed Changes. To the extent reasonably possible, consideration shall be given to using retaining walls or making other engineering adjustments as an alternative to the acquisition of Additional Properties. If it would be possible to use a retaining wall or other engineering adjustment to accommodate a Mobility Authority-Directed Change as an alternative to the acquisition of Additional Properties, the DB Contractor shall support its recommendation to acquire Additional Properties in lieu of constructing a retaining wall or otherwise modifying the Schematic Plan with an analysis demonstrating cost or time savings or other justification.

6.3.2 The DB Contractor shall not be entitled to any time extensions or cost increases for acquisition of DB Contractor-Designated ROW unless there is a Mobility Authority-Caused Delay pursuant to subparagraph (b) of the definition of that term.

6.3.3 In all cases, the DB Contractor shall exercise particular care to avoid acquisition of land owned by a public entity and used for a use inconsistent with highway use.

6.4 Representations by the DB Contractor

No member of the DB Contractor Group shall represent himself or herself as an agent of the Mobility Authority or TxDOT while communicating with any of the owners or occupants of the Final ROW, any property in which the DB Contractor seeks to obtain a temporary right or interest or a permanent right that will not be part of the Final ROW, or at any other time in connection with performing the services described in Technical Provision 7. No member of the DB Contractor Group shall appear before any owner or occupant of any Final ROW for the purposes of completing any of the documentation required under Technical Provision 7 without first presenting to that owner or occupant a letter, executed by the Mobility Authority or TxDOT, stating that the DB Contractor Group is working for the Mobility Authority or TxDOT, as the case may be, for the purposes of the acquisition of the Final ROW; provided, however, that the execution of, and approvals concerning, any relevant documentation shall be made by the Mobility Authority. The DB Contractor Group shall not represent itself as an agent for the Mobility Authority or TxDOT. Each member of the DB Contractor Group shall at all times conform with applicable Law (including, to the extent applicable, the Uniform Act) in all communications and actions with the owners or the occupants of the Final ROW or any other real property in which the DB Contractor seeks to obtain any right or interest. The DB Contractor shall send to each affected property owner by certified mail, return receipt requested, a copy of the latest version of the State of Texas Landowner's Bill of Rights as found on the website of the Office of the Attorney General of Texas.

6.5 Negotiations and Condemnation Proceedings Relative to the Acquisition of DB Contractor-Designated ROW

Negotiations for any DB Contractor-Designated ROW shall be undertaken as set forth in Technical Provision 7. The DB Contractor shall obtain the Mobility Authority's written approval of any offer to be extended to an owner of any interest in DB Contractor Designated ROW prior to making such offer, in accordance with Technical Provision 7. The DB Contractor shall notify the Mobility Authority in writing, for its concurrence, of the failure of negotiations with respect to the acquisition of any parcel of DB Contractor-Designated ROW and shall submit to the Mobility Authority for approval a condemnation package for the parcel as described in Technical Provision 7. The Mobility Authority shall have 15 Business Days either to (a) approve the package or (b) provide its comments and/or request for additional information to the DB Contractor if the Mobility Authority determines that the condemnation package is incomplete or otherwise deficient. The DB Contractor shall incorporate any suggested changes and provide any additional information requested by the Mobility Authority and shall resubmit the condemnation package to the Mobility Authority for review and approval. The Mobility Authority shall have 10 Business Days to approve or provide comments to the DB Contractor on any resubmittals. Failure of the Mobility Authority to provide the DB Contractor with its approval or, in the event the condemnation package is incomplete or otherwise deficient, its comments and/or request for additional information, within 15 Business Days of the Mobility Authority's receipt of a condemnation packet shall be considered a Mobility Authority-Caused Delay. Condemnation proceedings for any DB Contractor-Designated ROW will be initiated by the Mobility Authority, within a reasonable time following approval by the Mobility Authority of a complete condemnation package for the parcel. At no additional cost to the Mobility Authority, the DB Contractor shall cooperate in all respects with the Mobility Authority and TxDOT and shall cause all expert witnesses, appraisers, surveyors and other consultants utilized by the DB Contractor in

connection with the acquisition of DB Contractor-Designated ROW subject to condemnation to be available to and assist the Mobility Authority and TxDOT in connection with the condemnation proceedings, including discovery, depositions, pre-trial preparation and trial testimony. Counsel engaged for negotiations and/or condemnation proceedings shall be designated by the Mobility Authority. Delays to the Critical Path due to failure of the Mobility Authority to make DB Contractor Designated ROW available within 240 Days after approval of a condemnation packet shall be considered a Mobility Authority-Caused Delay. The term "make available", as used herein, shall mean to make available possession for construction free of occupancy by others and subject to any necessary demolition. The DB Contractor shall comply in all respects with the Uniform Relocation and Real Property Acquisition Policies Act of 1970, as amended with respect to its activities related to the acquisition of DB Contractor-Designated ROW.

6.6 Physical Possession of Final ROW; Failure by the Mobility Authority to Make Schematic ROW Available

6.6.1 The Mobility Authority shall notify the DB Contractor of the availability of Schematic ROW, and provide access thereto, within five (5) Business Days after the Mobility Authority has received access to such Schematic ROW. The DB Contractor shall be responsible for being informed of and complying with any access restrictions that may be set forth in any documents granting access to any Schematic ROW, provided that the Mobility Authority has provided such documents to the DB Contractor. Upon obtaining knowledge of any anticipated delay in the dates for acquisition of any Schematic ROW, the Party obtaining knowledge shall promptly notify the other party in writing. In such event, the DB Contractor shall immediately determine whether the delay impacts the Critical Path and, if so, to what extent it might be possible to avoid such delay through alternative construction methods or otherwise. The DB Contractor shall promptly meet with the Mobility Authority to determine the best course of action and prepare a written report setting forth its recommendations, which recommendations shall be subject to the written approval of the Mobility Authority. Notwithstanding anything in this DB Agreement to the contrary, the DB Contractor may not make a claim for a Change Order to extend the Completion Deadline or the Acceptance Deadline unless the Mobility Authority fails to make a parcel of Schematic ROW available for construction to the DB Contractor within 180 Days of the issuance of NTP1 and then only if such failure has a material adverse effect on the Critical Path. Any such failure by the Mobility Authority to make Schematic ROW available within 180 Days of issuance of NTP1 shall be considered a Mobility Authority-Caused Delay. In no event shall the DB Contractor be entitled to a Change Order to increase the DB Price or extend the Completion Deadline or the Acceptance Deadline as a result of the DB Contractor's failure to make available any DB Contractor-Designated ROW. All DB Contractor - Designated ROW will be acquired in accordance with the procedures described in *Technical Provision 7*.

6.6.2 The DB Contractor shall be responsible for being informed of and complying with any covenants and restrictions set forth in the deeds and any other related real property purchase and sale documents pertaining to the Mobility Authority's or TxDOT's acquisition of any Final ROW, provided that the Mobility Authority has provided such documents to the DB Contractor.

6.7 Rights of Early Access

To the extent that the DB Contractor has not been provided with access to portions of the Schematic ROW prior to the date set forth on the Project Schedule, the DB Contractor shall work around such Schematic ROW with the goals of minimizing delay to the completion of the Project. Except for delays caused by the type of event described in *clause (b)* or *clause (c)* of the definition of "**Mobility Authority-Caused Delay**", the DB Contractor shall not be entitled to any time extension for delays caused by the failure or inability of the Mobility Authority to provide Schematic ROW. Where the DB Contractor makes a written request for access or rights of entry for any Schematic ROW for which access has not yet been acquired, the DB Contractor may, with the Mobility Authority's written consent, negotiate with property owners or occupants for early access or temporary use of land, provided there is no violation of applicable Law. The DB Contractor's negotiations with property owners or occupants for early rights-of-entry shall occur only under such terms and conditions as are stipulated by the Mobility Authority, with the proviso that the Mobility Authority's consent may be withheld or withdrawn at any time, in the Mobility Authority's sole discretion. The Mobility Authority shall not be bound by the terms and conditions agreed upon by the DB Contractor and any property owner or occupant until such time as the Mobility Authority has expressly so indicated in writing (and, then, only to the extent expressly set forth therein).

7. COMMENCEMENT OF CONSTRUCTION; CONSTRUCTION PROCEDURES; HAZARDOUS MATERIALS; NEW ENVIRONMENTAL APPROVALS

7.1 Commencement of Construction

The DB Contractor shall not commence construction of any portion of the Project prior to occurrence of all the following events, except with the prior written approval of the Mobility Authority, in its sole discretion:

7.1.1 The Mobility Authority shall have approved (a) the Safety Plan; (b) the Hazardous Materials Management Plan; and (c) the CQMP.

7.1.2 All Governmental Approvals necessary for construction of the applicable portion of the Project shall have been obtained and all conditions of such Governmental Approvals which are a prerequisite to commencement of such construction shall have been performed.

7.1.3 All required insurance and bonds shall remain in full force and effect.

7.1.4 The Mobility Authority (either directly or through the DB Contractor) shall have acquired the real property upon which the construction will be conducted or the Mobility Authority or the DB Contractor shall have obtained approval to enter into physical possession of the property upon which work will be performed, including, where necessary, approval to enter by means of a right of entry; provided, however, that the DB Contractor shall not refrain from commencing construction on any portion of the Project based on any failure to obtain physical possession of one or more properties required for construction elsewhere on the Project.

7.1.5 The DB Contractor shall have completed all required investigations to establish and confirm the existence and location of Utilities in such portion of the Project.

7.1.6 The Mobility Authority shall have issued NTP2.

7.1.7 The DB Contractor shall have submitted the Preliminary (30%) Design Submittal for the entire Project and such submittal shall have been accepted by the Mobility Authority in accordance with Technical Provision 2, including an adequate response by the DB Contractor to all Mobility Authority comments.

7.1.8 Except as otherwise provided in Technical Provision 2 regarding Early Start of Construction, the Design Documents for the applicable portion of the Project shall have been accepted by the Mobility Authority in accordance with Technical Provision 2, and shall have been through the DQMP process.

7.1.9 The DB Contractor shall have met any other requirement specified in Technical Provision 2 and Technical Provision 23 for commencement of construction operations.

Notwithstanding this Section 7.1, the DB Contractor may commence construction directly related to Utility Adjustment Work prior to meeting the requirements of Sections 7.1.6 and 7.1.7 above.

7.2 Supervision and Construction Procedures

7.2.1 The DB Contractor shall be solely responsible for and have control over construction means, methods, techniques, sequences, procedures and Site safety and for coordinating all portions of the Work under the Contract Documents, subject, however, to all requirements contained in the Contract Documents.

7.2.2 As between the DB Contractor and the Mobility Authority, the DB Contractor shall be solely responsible for implementing, maintaining and supervising the approved Safety Plan in accordance with Technical Provision 25. The DB Contractor shall take all reasonable precautions and be solely responsible for the safety of, and shall provide protection to prevent damage, injury or loss to: (a) all employees of the DB Contractor and its Subcontractors performing the Work and other persons who are on the Site or would reasonably be expected to be affected by the Work; (b) the Work and materials and equipment to be incorporated therein; and (c) all other property within or adjacent to the Site; provided that the DB Contractor's responsibilities under this section are limited to those risks associated directly or indirectly with the Work.

7.2.3 The DB Contractor shall use commercially reasonable efforts to cause all of its activities and the activities of its employees, agents, officers and Subcontractors and all other Persons for whom the DB Contractor may be legally or contractually responsible to be undertaken in a manner that will minimize the effect on surrounding property and the public.

7.3 Inspection and Testing

7.3.1 The DB Contractor shall perform the inspection, sampling and testing necessary to comply with its obligations under the Contract Documents, in accordance with its approved CQMP and the Mobility Authority's QAP. At all points in performance of the Work at which specific inspections, acceptances or approvals by the Mobility Authority are required by the Contract Documents, the DB Contractor shall not proceed beyond that point until the Mobility Authority has completed such inspection, acceptance, or approval or waived its right to inspect, accept or

approve, which waiver shall be in writing. Inspections shall be performed in accordance with the time limits specified in the CQMP and the Mobility Authority's QAP.

7.3.2 As part of the Mobility Authority's Material Acceptance and oversight role as described in Technical Provision 2, all materials and each part or detail of the Work shall also be subject to inspection and testing by the Mobility Authority. When any Governmental Entity, Utility Owner or railroad is to accept or pay for a portion of the cost of the Work, its respective representatives have the right to inspect the work. Such inspection does not make such Person a party to this DB Agreement nor will it change the rights of the parties hereto. The DB Contractor hereby consents to such inspection and testing. In the event that such inspection and testing results in a failed test, the Mobility Authority may require the DB Contractor to reimburse the Mobility Authority for its reasonable costs related to retesting. Such reasonable costs may be deducted from payments to be made by the Mobility Authority pursuant to Section 13 hereof.

7.3.3 At all times before Final Acceptance, the DB Contractor shall remove or uncover such portions of the finished construction Work as directed by the Mobility Authority. After examination by the Mobility Authority, the DB Contractor shall restore the Work to the standard required by the Contract Documents. If the Work exposed or examined is not in conformance with the requirements of the Contract Documents, then the cost of uncovering, removing and restoring the Work and of recovery of any delay to the Critical Path occasioned thereby shall be at the DB Contractor's expense. Furthermore, any Work done or materials used without adequate notice to and opportunity for prior inspection by the Mobility Authority, as required in Technical Provision 2, may be ordered uncovered, removed or restored at the DB Contractor's expense, even if the Work proves acceptable and in conformance after uncovering. Except with respect to Work done or materials used as described in the preceding sentence, if Work exposed or examined under this Section 7.3.3 is in conformance with the requirements of the Contract Documents, then any delay in the Critical Path from uncovering, removing and restoring Work shall be considered a Mobility Authority-Caused Delay, and the DB Contractor shall be entitled to a Change Order for the cost of such efforts and recovery of any delay to any Critical Path occasioned thereby, subject to the provisions of Section 14 hereof.

7.4 Correction of Nonconforming Work

7.4.1 Subject to the Mobility Authority's unilateral right to accept or reject Nonconforming Work, rejected Nonconforming Work shall be removed and replaced so as to be acceptable to the Mobility Authority, at the DB Contractor's expense; and the DB Contractor shall promptly take all action necessary to prevent similar deficiencies from occurring in the future. The fact that the Mobility Authority may not have discovered the Nonconforming Work shall not constitute an acceptance of such Nonconforming Work. If the DB Contractor fails to correct any Nonconforming Work, or fails to provide an acceptable schedule to complete such Nonconforming Work and then begins such work, within five (5) Days of receipt of notice from the Mobility Authority requesting correction, unless such Nonconforming Work does not pose a risk to health or safety, and due to the nature of the work, correction of such cannot begin within five (5) days, then, in this case, if Contractor does not implement correction of such work within the time provided under the Project Schedule, then the Mobility Authority may (i) impose a fee of \$2,500 per Day until the DB Contractor corrects such Nonconforming Work or provides an acceptable schedule for its completion, (ii) issue a stop work order pertaining to the portion of work directly impacted by the Nonconforming Work until such correction is made or acceptable schedule for

completion is provided, and/or (iii) cause the Nonconforming Work to be remedied or removed and replaced and may deduct the cost of doing so from any moneys due or to become due to the DB Contractor and/or obtain reimbursement from the DB Contractor for such cost (plus interest thereon at the maximum rate allowable under applicable Law). The procedures for correction of Nonconforming Work set forth in the CQMP shall be consistent with the requirements of this Section 7.4.

7.4.2 The Mobility Authority may, but shall not be obligated to, accept any Nonconforming Work without requiring it to be fully corrected. In such event, the Mobility Authority shall be entitled to reimbursement of a portion of the DB Price equal to the greater of (a) the diminution in value of the Project attributable to the Nonconforming Work, including the present value of future maintenance and repair costs that the Mobility Authority anticipates may be required as a result of the nonconformity, and (b) the difference between the cost of performing the work in question in accordance with the Contract Documents and the actual cost of performing the Nonconforming Work. In the event that the Mobility Authority determines that (b) is greater than (a) in the previous sentence, then the Mobility Authority shall allow the DB Contractor the option (exercisable within ten (10) Business Days of written notice from Mobility Authority of such determination) to provide reimbursement or to correct the Non-Conforming Work, at the DB Contractor's expense. Such reimbursement by the DB Contractor shall be made within ten (10) Days of the Mobility Authority's submittal to the DB Contractor of an invoice therefor and shall accrue interest at the maximum rate allowable under applicable Law. Alternatively, the Mobility Authority may deduct the amount owing from any sum owed by the Mobility Authority to the DB Contractor pursuant to this DB Agreement. Where applicable, the Mobility Authority shall apply TxDOT Standard Specifications and TxDOT Prices criteria in determining the amount of reduction in the DB Price related to the Nonconforming Work.

7.4.3 If the Mobility Authority (at its sole discretion) requires construction modifications or changes to already-completed Project elements performed under the Released-for-Construction ("RFC") provisions due to noncompliance with Contract Documents, DB Contractor shall make any and all such construction modifications, removals, or reconfigurations at its sole cost and expense, without any entitlement to time extensions or adjustment in the DB Price.

7.5 Hazardous Materials Management

7.5.1 Procedures and Compensation for Hazardous Materials Management

7.5.1.1 If during the course of the Work, the DB Contractor encounters material quantities of Hazardous Materials, the DB Contractor shall (a) promptly notify the Mobility Authority in writing and advise the Mobility Authority of any obligation to notify State or federal agencies under applicable Laws; and (b) take reasonable steps, including design modifications and/or construction techniques, to avoid excavation or dewatering in areas with Hazardous Materials. Where excavation or dewatering of Hazardous Materials is unavoidable, the DB Contractor shall utilize appropriately trained personnel and shall implement the most cost-effective approach to Hazardous Materials Management, as directed by the Mobility Authority. The DB Contractor's plan for Hazardous Materials Management shall be subject to the prior written approval of the Mobility Authority and shall be in accordance with Technical Provision 9. For purposes of this section, the term "material quantities" means only quantities that would require reporting or other action under Federal or State Law. Wherever feasible and consistent with

applicable Laws, contaminated soil and groundwater shall not be disposed off-site. All Hazardous Materials shall be managed in accordance with applicable Laws, Governmental Approvals, the Hazardous Materials Management Plan, the approved investigative work plan described in Technical Provision 9, the approved site investigation report described in Technical Provision 9 and the Safety Plan.

7.5.1.2 The DB Contractor shall afford the Mobility Authority the opportunity to inspect sites containing Hazardous Materials before any action is taken which would inhibit the Mobility Authority's ability to ascertain the nature and extent of the contamination.

7.5.1.3 Subject to the limitations and exceptions set forth in this Section 7.5, and Section 14, the DB Contractor shall be entitled to a Change Order as set forth in Section 14.8 with respect to additional costs and/or delays directly attributable to the discovery of (a) Unknown Hazardous Materials within the Schematic ROW; (b) Hazardous Materials on any parcels added to the Site by a Mobility Authority-Directed Change other than as a result of Releases of Hazardous Materials by the DB Contractor; or (c) Hazardous Materials falling within the definition of a Force Majeure Event. The amount of additional compensation or extension of time in any Change Order allowed hereunder shall be determined in accordance with Section 14.8. Entitlement to compensation or a time extension shall be limited to costs of work performed pursuant to the DB Contractor's Hazardous Materials Management Plan, investigative work plan and site investigation report for such Hazardous Materials as approved by the Mobility Authority, in writing (provided that approval by the Mobility Authority shall not be required for costs incurred in connection with immediate or emergency response actions performed at the direction of the Environmental Team). No compensation or time extension shall be allowed with respect to (a) immaterial quantities of Hazardous Materials (for these purposes, quantities shall be considered immaterial if Direct Costs related to their removal would not reasonably exceed \$10,000), (b) any Hazardous Materials that could have been avoided by reasonable design modifications or construction techniques (provided the DB Contractor shall be entitled to a Change Order for reasonable costs of redesign where the discovery of Hazardous Materials requires a change to the DB Contractor's already existing design plans), (c) any costs that could have been reasonably avoided, or (d) Hazardous Materials on any other Additional Properties or New Utility Property Interests. To the extent that any proceeds of insurance are available to pay the cost of any Hazardous Materials Management, the DB Contractor shall rely on insurance to provide compensation, in lieu of requesting a Change Order for additional costs. Notwithstanding any other provision of this DB Agreement, the Mobility Authority shall have the right to direct the DB Contractor to allow the Mobility Authority or its designee to provide some or all Hazardous Materials management, in which case no Change Order for additional costs shall be issued for such work, but the DB Contractor may be entitled to a Change Order providing for a time extension in accordance with Section 14.8.

7.5.2 Hazardous Materials Generator

As between the DB Contractor and the Mobility Authority, and except as provided herein, the Mobility Authority shall be considered the generator of and arranger of (i) Hazardous Materials on the Final ROW as of the Effective Date, (ii) Hazardous Materials on any Additional Properties acquired after the Effective Date (other than the DB Contractor – Designated ROW) and (iii) any Releases of Hazardous Materials on the Final ROW by the Mobility Authority, and, subject to the DB Contractor's obligation to pay certain costs pursuant to Section 14.8, shall have the

responsibility for all Hazardous Materials Management costs including assessment, containment and remediation expenses related thereto; provided, however, that the foregoing shall not preclude or limit any rights or remedies that the Mobility Authority may have against third parties and/or prior owners, lessees, licensees and occupants of the Final ROW. The DB Contractor shall be considered the generator of any Hazardous Materials which result from (a) Release(s) of Hazardous Material attributable to the negligence, willful misconduct, or breach of applicable Law or contract by any member of the DB Contractor Group; and (b) Release(s) of Hazardous Materials arranged to be brought onto the Final ROW or elsewhere by any member of the DB Contractor Group unless Mobility Authority is responsible for the Release of such Hazardous Materials pursuant to clause (iii) of the first sentence of this Section 7.5.2; provided, however, that the foregoing shall not preclude or limit any rights or remedies that the DB Contractor may have against third parties.

7.5.3 Hazardous Materials Releases Caused by the DB Contractor

Hazardous Materials Management costs, including assessment, containment, and remediation expenses, which result from (a) Release(s) of Hazardous Materials attributable to the actions, omissions, negligence, willful misconduct, or breach of applicable Law or contract by any member of the DB Contractor Group; or (b) Release(s) of Hazardous Materials arranged to be brought onto the Final ROW or elsewhere by any member of the DB Contractor Group shall not be the responsibility of the Mobility Authority or compensable to the DB Contractor, regardless of the cause of the Release of Hazardous Materials. The DB Contractor shall be fully responsible for all Hazardous Materials Management costs associated with such Hazardous Materials.

7.5.4 Materials Brought to Final ROW by the DB Contractor

The DB Contractor shall be solely responsible for: (a) compliance with all Laws applicable to Hazardous Materials brought onto the Site by any member of the DB Contractor Group; (b) use, containment, storage, management, transport and disposal of all such Hazardous Materials in accordance with this DB Agreement and all applicable Laws and Environmental Approvals; and (c) payment of all penalties, expenses (including attorneys' fees and costs), costs, suits, judgments, claims, actions, damages (including damages to natural resources, property or Persons), delays and liability associated with, arising out of or related to such Hazardous Materials, including any of the foregoing incurred or suffered by the Mobility Authority.

7.5.5 Environmental Approvals Relating to Hazardous Materials

It is the responsibility of the DB Contractor to obtain, on behalf of the Mobility Authority, all Governmental Approvals relating to Hazardous Materials Management performed by the DB Contractor at the direction of the Mobility Authority including federal and State surface water and groundwater discharge permits and permits for recycling or reuse of Hazardous Materials. The DB Contractor shall be solely responsible for compliance with such Governmental Approvals and applicable Laws, including those governing the preparation of waste profiles, waste manifests and bills of lading. The Mobility Authority has exclusive decision-making authority regarding selection of the destination facility to which the pre-existing Hazardous Materials will be transported. With regard to pre-existing Hazardous Materials, the Mobility Authority shall comply with the applicable standards for generators and arrangers including those found at 40 C.F.R., Part 262, including the responsibility to sign manifests for the transport of hazardous wastes. The

foregoing shall not preclude or limit any rights, remedies or defenses that the Mobility Authority or the DB Contractor may have against any Governmental Entity or third parties, including prior owners, lessees, licensees and occupants of any parcel of land that is or becomes part of the Final ROW properties as of the Effective Date.

7.5.6 Indemnification

To the extent permitted by applicable Law, the Mobility Authority shall indemnify, save, protect and defend the DB Contractor from third party claims, causes of action and Losses arising out of or related to generator or arranger liability for the pre-existing Hazardous Materials and Hazardous Materials from the Mobility Authority Release(s) of Hazardous Material for which the Mobility Authority is considered the generator and arranger pursuant to this Section, specifically excluding generator and arranger liability for actual and threatened DB Contractor Releases of Hazardous Materials.

7.6 Environmental Compliance

The DB Contractor shall be responsible for performance of all environmental mitigation measures (which term shall be deemed to include all requirements of the Environmental Approvals, including the Mobility Authority-Provided Approvals and similar Governmental Approvals, regardless of whether such requirements would be considered to fall within a strict definition of the term) for the Project (other than those which the Mobility Authority has expressly agreed to perform under the Contract Documents). The DB Price includes compensation for the DB Contractor's performance of all such mitigation measures provided, however, the DB Price does not include compensation for the DB Contractor's performance of environmental mitigation matters for which the DB Contractor is entitled to additional time and/or monetary compensation under Section 14 or for which the Mobility Authority is responsible under this DB Agreement, or Hazardous Materials of which the Mobility Authority is the generator under Section 7.5.2.

7.6.1 Mobility Authority's Responsibility for Approvals

7.6.1.1 All mitigation requirements contained in the final Mobility Authority-Provided Approvals shall automatically be deemed included in the scope of the Work. In the event that the final Mobility Authority-Provided Approvals (inclusive of the final Environmental Documents) have been provided to the DB Contractor prior to the Proposal Due Date, and they incorporate mitigation requirements addressing any modification in the Project Design from the original design concept included in the draft Environmental Documents, such additional mitigation requirements shall be the DB Contractor's responsibility and shall not be considered a Mobility Authority-Directed Change or a Force Majeure Event.

7.6.1.2 The DB Contractor shall be responsible for obtaining any New Environmental Approvals required for the Project. In the event any New Environmental Approval is necessitated by a Mobility Authority-Directed Change or a Force Majeure Event, the DB Contractor shall be responsible for obtaining such New Environmental Approval and/or performing any additional mitigation requirements of such New Environmental Approval only if directed to do so by a Directive Letter or a Change Order. The Mobility Authority shall cooperate with the DB Contractor and support its efforts to obtain any such New Environmental Approval. Any Change Order covering a Mobility Authority-Directed Change or a Force Majeure Event shall

include compensation to the DB Contractor for additional costs incurred by the DB Contractor to obtain the New Environmental Approval and to implement any changes in the Work (including performance of additional mitigation measures) resulting from such New Environmental Approvals, as well as any time extension necessitated by a Mobility Authority-Directed Change or a Force Majeure Event, subject to the conditions and limitations contained in Section 14.

7.6.2 Approvals to be Obtained by the DB Contractor

7.6.2.1 If it is necessary to obtain a New Environmental Approval for any reason other than a Force Majeure Event or a Mobility Authority-Directed Change, the DB Contractor shall be fully responsible, at its sole cost and expense, for obtaining the New Environmental Approval and any other environmental clearances that may be necessary, and for all requirements resulting therefrom, as well as for any litigation arising in connection therewith.

8. DISADVANTAGED BUSINESS ENTERPRISE; CIVIL RIGHTS

8.1 DBE Requirements

8.1.1 The Mobility Authority has adopted a Disadvantaged Business Enterprise ("DBE") Policy Statement and a Business Opportunity Program and Policy ("BOPP") to facilitate and encourage the participation of disadvantaged and small businesses in Mobility Authority Procurements. The DBE Policy Statement is attached as Exhibit H. Pursuant to the BOPP, all Mobility Authority contracts funded in whole or in part with federal funds received from the United States Department of Transportation ("DOT"), including funds received through the Federal Highway Administration ("FHWA"), or funded in whole or in part with such federal funds received by the Mobility Authority through TxDOT, are subject to TxDOT's DBE Program, adopted by the Mobility Authority through a Memorandum of Understanding with TxDOT. The DBE Program provides DBEs full opportunity to participate in all Mobility Authority contracts in accordance with 49 C.F.R. Part 26. The goals for DBE participation are determined by the Mobility Authority and/or TxDOT in accordance with the requirements and formulas set forth in 49 C.F.R. Part 26 and applicable rules promulgated thereunder. The DB Contractor shall comply with all requirements set forth in (i) the Mobility Authority's DBE Program, and (ii) the DB Contractor's FHWA approved DBE Performance Plan adopted by the DB Contractor in accordance with (i).

8.1.2 The DBE participation goal with respect to design services included in the Work is 10% of the DB Price attributable to design and other related professional services including ROW acquisition services, if any. The DBE participation goal with respect to all other Work is 9% of the DB Price attributable to such work.

8.1.3 The DB Contractor shall include provisions to effectuate this Section 8 and Exhibit H in every Subcontract (including purchase orders and in every subcontract of any member of the DB Contractor Group for Work), and shall require that they be included in all Subcontracts at lower tiers, so that such provisions will be binding upon each Subcontractor. In the event the DB Contractor intends to perform operations and maintenance work with respect to the Project, the DB Contractor agrees to use good faith efforts to encourage DBE participation in the performance of such work.

8.1.4 The DB Contractor shall not cancel or terminate any Subcontract with a DBE firm except in accordance with all requirements and provisions applicable to cancellation or termination of Subcontracts with DBE firms set forth in TxDOT's DBE Special Provision.

8.2 Civil Rights

8.2.1 The DB Contractor shall not, and shall cause the Subcontractors to not, discriminate on the basis of race, color, national origin or sex in the performance of the Work under the Contract Documents. The DB Contractor shall carry out, and shall cause the Subcontractors to carry out, applicable requirements of 23 C.F.R. Part 230 in the award and administration of FHWA-assisted agreements. Failure by the DB Contractor to carry out these requirements is a material breach of this DB Agreement, which may result in the termination of the Contract Documents or such other remedy as the Mobility Authority or TxDOT deems appropriate.

8.2.2 In all solicitations either by competitive bidding or negotiation made by the DB Contractor for Work to be performed by a Subcontractor, including procurement of materials or leases of equipment, the DB Contractor shall notify each potential Subcontractor of such Subcontractor's obligations under this Section 8.2 and of the federal regulations relative to nondiscrimination. The DB Contractor shall include Section 8.2.1 in every Subcontract (including purchase orders), and shall require that they be included in all Subcontracts at lower tiers, so that such provisions will be binding upon each Subcontractor. The Mobility Authority shall have the right to review all Subcontracts to assure compliance with this provision.

9. PERFORMANCE AND PAYMENT SECURITY

The DB Contractor shall deliver to the Mobility Authority, and maintain in full force and effect at all times, security for performance of the Work as described below (or other assurance satisfactory to the Mobility Authority in its sole discretion).

9.1 Proposal Bond

The DB Contractor has provided a Proposal Bond to the Mobility Authority in the amount of \$10,000,000. The Proposal Bond shall remain in place as security for performance of the DB Contractor's obligations under the Contract Documents during the period prior to issuance of NTP1, including the DB Contractor's obligation to provide the Performance Bond and Payment Bond hereunder. Upon the Mobility Authority's receipt of the Performance Bond and the Payment Bond and all other documents required to be provided to the Mobility Authority on or before issuance of NTP1, the Mobility Authority shall release the Proposal Bond.

9.2 Performance Bond

Upon the issuance by the Mobility Authority of NTP1, the DB Contractor shall deliver to the Mobility Authority a performance bond in the amount of the DB Price and in the form attached hereto as Exhibit I (the "**Performance Bond**"). After Final Acceptance of the Project, the Mobility Authority shall provide a written release of the Performance Bond, provided that all of the following have occurred: (a) the DB Contractor is in compliance with the terms of the Contract Documents and is not in default thereunder; (b) no event has occurred that with the giving of notice or passage of time would constitute a default by the DB Contractor hereunder or under the Contract

Documents; and (c) the Mobility Authority has received the Warranty Bond. TxDOT shall be named an additional obligee on the Performance Bond.

9.3 Payment Bond

Upon the issuance by the Mobility Authority of NTP1, the DB Contractor shall deliver to the Mobility Authority a labor and material payment bond in the amount of the DB Price and in the form attached hereto as Exhibit J (the "**Payment Bond**"). The Mobility Authority shall provide a written release of the Payment Bond the later of (a) one year after Final Acceptance, provided that the DB Contractor has delivered to the Mobility Authority (i) evidence satisfactory to the Mobility Authority that all Persons performing the Work have been fully paid, (ii) unconditional waivers of claims in form and substance satisfactory to the Mobility Authority, executed by all of such Persons, and (iii) the Warranty Bond; or (b) upon expiration of the statutory period for Subcontractors to file a claim against the bond for Work, provided that the Mobility Authority has received the Warranty Bond. TxDOT shall be named an additional obligee on the Payment Bond.

9.4 Warranty Bond

After Final Acceptance and subject to the requirements herein, the DB Contractor may obtain a release of the Performance and Payment Bonds by providing a warranty bond which shall guarantee performance of the Work required to be performed during the Warranty period and which shall also constitute a payment bond guaranteeing payment to Persons performing such Work ("**Warranty Bond**"). The Warranty Bond shall be in the amount of 10% of the DB Price and shall be in the form attached hereto as Exhibit K. TxDOT shall be named an additional obligee on the Warranty Bond.

9.5 Surety Financial Requirements

Any bond provided in accordance with this Section 9 shall be issued by a Surety with an A.M. Best and Company rating level of A-minus (A-) or better, Class VIII or better, or as otherwise approved in writing by the Mobility Authority, in its sole discretion.

9.6 Performance by Surety or Guarantor

Performance by a Surety or a Guarantor of any of the obligations of the DB Contractor shall not relieve the DB Contractor of any of its obligations hereunder.

9.7 Guarantee

9.7.1 If at any time during the course of the DB Agreement the total combined Tangible Net Worth of the DB Contractor, its equity members and any Guarantors, if any, is less than \$100,000,000 (excluding Tangible Net Worth in excess of any applicable limit of liability stated in the guarantee), the DB Contractor shall provide one or more guarantees making up the difference. Each such guarantee shall be in the form attached to the Instructions to Proposers as Form N together with appropriate evidence of authorization thereof, and the total liability thereunder shall be equal to or greater than the difference between \$100,000,000 and such total combined Tangible Net Worth. Each guarantee must be provided by (a) a parent corporation, a

shareholder or another Affiliate of the DB Contractor, or (b) a parent corporation or a shareholder of an equity member of the DB Contractor.

10. INSURANCE

The DB Contractor shall purchase and continuously maintain in full force and effect through Project Final Acceptance, or such longer or shorter time as may be specifically provided below, the insurance coverages specified in this Section 10. These insurance coverage requirements are also subject to all other applicable sections of the Contract Documents. The insurance, except for professional liability and worker's compensation, provided hereunder shall be available for the benefit of the Mobility Authority and the DB Contractor with respect to covered claims, but shall not be interpreted to relieve the DB Contractor of any obligations hereunder. All insurance required hereunder shall be procured from insurance or indemnity companies with an A.M. Best and Company rating level of A- or better, Class VIII or better, or as otherwise approved by the Mobility Authority and authorized or approved to do business in the State. All limits of liability set forth below are in U.S. dollars.

10.1 [Reserved]

10.2 Insurance After Issuance of NTP1

During the period commencing with the date on which the Mobility Authority issues NTP1 and ending at Project Final Acceptance (unless otherwise specified herein), the DB Contractor shall provide and maintain insurance as specified in this Section 10.2.

10.2.1 Commercial General Liability Insurance

(a) The DB Contractor shall provide and maintain commercial general liability coverage (for bodily injury, property damage, personal injury and advertising injury) during the period starting on the date on which the Mobility Authority issues NTP1 and ending on the date of Final Acceptance using an ISO CG 00 01 (12/07) occurrence form (or equivalent), specifically including coverage for contractual liability per standard ISO policy terms, premises operations, independent contractors, products and completed operations, broad form property damage and hazards commonly referred to as "XCU," with limits of \$2,000,000 per occurrence and \$4,000,000 general per project aggregate. The policy shall not include any professional liability exclusion as it relates to "means and methods" of construction. The definition of "Insured Contract" in the policy should be amended to state that "professional services" does not include "means and methods" of construction. The policy shall include the Limited Exclusion-Contractors-Professional Liability Endorsement CG22-80, CG22-79, or their equivalent. There shall be no exclusion for work performed on or within 50 feet of any railroad property. The definition of "Insured Contract" in the policy shall include that part of any contract or agreement that indemnifies a railroad for bodily injury or property damage arising out of construction or demolition operations on or within 50 feet of any railroad property. The policy shall include a "Limited Coverage – Repair Work Endorsement" that shall extend coverage under the policy for warranty repair work from Final Acceptance until the end of the Warranty Period. The policy shall include products and completed operations extended coverage in the amount of \$4,000,000, and this coverage shall be maintained until the end of the Warranty Period. The DB Contractor shall be the named insured and each of the Indemnified Parties, including the railroad(s), shall be

additional insureds, on a primary and non-contributory basis. The policy deductibles shall not exceed 5% of the policy limits.

(b) If the DB Contractor's commercial general liability insurance or other form with a general aggregate limit is used, then the aggregate limits shall apply separately to the Project, or the DB Contractor may obtain separate project specific insurance to provide the required limit which shall not be subject to depletion because of claims arising out of any other project or activity of the DB Contractor. The policy terms, conditions, coverage and limit requirements for the project specific policy are the same as referenced in (a) above. Notwithstanding any other provision of the Contract Documents, the project policy shall not be cancellable, except for non-payment of premium, fraud, material misrepresentation, or non-compliance with reasonable loss control recommendations.

10.2.2 Umbrella Excess Liability

(a) The DB Contractor shall provide and maintain umbrella excess liability coverage with limits of \$30,000,000 per occurrence and \$30,000,000 per project aggregate on the same basis as outlined in *Sections 10.2.1 (a) or (b)* above, *10.2.3* and *10.2.4*. Any such umbrella excess insurance shall be at least as broad as the DB Contractor's primary insurance.

10.2.3 Workers' Compensation Insurance and Employer's Liability Insurance

If applicable, during the period commencing on the date on which the Mobility Authority issues NTP1 and ending on the date of Project Final Acceptance, the DB Contractor shall provide and maintain worker's compensation insurance in conformance with applicable Law and employer's liability insurance (for bodily injury or disease) with limits of \$1,000,000 per accident for all of its employees involved with the performance of the Work. The DB Contractor shall be the named insured on these policies. The worker's compensation coverage will contain the following endorsements:

- (a) An endorsement extending the policy to cover the liability of the insureds under the Federal Employer's Liability Act.
- (b) A voluntary compensation endorsement.
- (c) An alternate employer endorsement.
- (d) An endorsement extending coverage to all states operations on an "if any" basis.

10.2.4 Business Automobile Liability Insurance

The DB Contractor shall provide and maintain business automobile liability insurance, commencing on the date on which the Mobility Authority issues NTP1 and ending upon the date of Project Final Acceptance, covering the DB Contractor's legal liability arising out of the ownership, operation, maintenance or use of all owned/leased, non-owned and hired vehicles used in the performance of the Work, including loading and unloading, with limits of not less than \$2,000,000 combined single limit for bodily injury and property damage liability; provided, however, that such coverage shall be maintained for vehicles used in performance of Warranty

work until the expiration of the Warranties. The DB Contractor shall be the named insured and each of the Indemnified Parties shall be named as additional insureds, on a primary and non-contributory basis, with respect to liability arising out of the acts or omissions of any member of the DB Contractor Group, whether occurring on or off of the Site. The policy shall include auto pollution liability coverage. The policy deductibles shall not exceed 5% of the policy limits.

10.2.5 Professional Liability Insurance

The DB Contractor shall provide and maintain or cause its lead design Subcontractor to provide professional liability coverage, through a specific project professional liability policy, with limits not less than \$10,000,000 per negligent act, error or omission limit and \$10,000,000 aggregate. The professional liability coverage shall protect against any negligent act, error or omission arising out of design or engineering services performed by the DB Contractor's lead design Subcontractor or its lower tier design subcontractors or subconsultants. The policy shall have a retroactive date no later than the date on which the RFDP Documents are issued and shall have a five-year extended reporting period from the date of Final Acceptance with respect to claims or suits which were not made or brought during the term of the policy. The coverage shall include the DB Contractor's lead design Subcontractor and its design subcontractors and subconsultants of any tiers. The policy shall include a Notice of Circumstance provision. The policy shall not contain any exclusion for cost estimates or delay in project completion. Notwithstanding any other provisions of the Contract Documents, the project policy shall not be cancellable, except for non-payment of premium, fraud, material misrepresentation, or pursuant to a material variance endorsement. As an alternative to the project specific coverage described above, the DB Contractor may instead substitute the professional liability coverage that it or its lead design firm carries provided that (a) such coverage is in the amount of at least \$20,000,000 per negligent act, error or omission and \$20,000,000 aggregate, (b) such policy is maintained until at least five (5) years following Substantial Completion of the Project, and (c) the owner of the policy provides the Mobility Authority, on an annual basis, with a current certificate of insurance and a copy of its financial statements, including balance sheet, income statement, and statement of cash flow.

10.2.6 Pollution Liability Insurance

The DB Contractor shall provide and maintain Contractor's Pollution Liability coverage on an occurrence basis, through a Specific Project Pollution Liability Policy, with limits not less than \$5,000,000 per "pollution incident" and \$5,000,000 aggregate. The pollution liability coverage shall protect against the DB Contractor's legal liability arising out of any construction and related activities with respect to the Project, including off site activities related to transportation and/or disposal. The policy shall provide coverage from the date on which the NTP1 is issued until five (5) years from the date of Final Acceptance. The policy shall include coverage for damage (including loss of use of) to natural resources. Each of the Indemnified Parties shall be named as an additional insured, on a primary and non-contributory basis, to this policy with respect to liability arising out of the acts, errors, and omissions of any member of the DB Contractor Group and Subcontractors whether occurring on or off of the site. Notwithstanding any other provisions of the Contract Documents, the project policy shall not be cancellable, except for non-payment of premium, fraud, material misrepresentation, or non-compliance with reasonable loss control recommendations.

10.2.7 Builder's Risk

The DB Contractor shall procure and maintain builder's risk insurance for the Project as specified below. The insureds shall be the DB Contractor, all Subcontractors (excluding those solely responsible for design Work) of any tier, and each of the Indemnified Parties, as their interests may appear. The insurance shall be maintained during the period starting on the date of commencement of construction and ending on the date of Substantial Completion.

10.2.7.1 **Minimum Scope:** A blanket builder's risk insurance policy on an "all risk" basis for the entire Project including: (1) coverage for resulting property damage caused by faulty workmanship, use of Nonconforming Work materials, omission or deficiency in design or specifications; (2) coverage against damage or loss caused by the perils of fire (with extended coverage), earth movement, flood, theft, vandalism and malicious mischief and machinery accidents; (3) coverage for removal of debris, contaminants and pollutants (as defined in the policy) including demolition from the enforcement of any applicable local, state, or federal requirement, and insuring the buildings, structures, machinery, equipment, facilities, fixtures and all other properties constituting a part of the Project; (4) inland transit coverage (ocean marine coverage, if applicable, shall be provided through a separate Ocean Marine insurance policy unless insured by the supplier), with sub-limits sufficient to insure the full replacement value of any key equipment item; (5) coverage with sub-limits sufficient to insure the full replacement value of any property or equipment stored either on or off the Site, and (6) coverage for architect and engineering fees required as a result of a covered loss. Such insurance shall be on a form acceptable to the Mobility Authority and shall have a limit equal to the probable maximum loss to replace the completed Project plus "soft cost expense cover," as defined in the policy (including, at a minimum, attorneys' fees and fees and other costs associated with such damage or loss and with any Governmental Approvals), with a limit of \$5,000,000 and shall include flood insurance with a \$25,000,000 minimum annual aggregate limit. There shall be no coinsurance penalty provision in any such policy. Ocean Marine coverage, if applicable, shall be provided through this insurance or separate Ocean Marine insurance. Deductibles or self-insured retentions shall not exceed 5% of the policy limits.

10.2.8 Valuable Papers

The DB Contractor shall provide valuable papers insurance with a limit of not less than \$200,000 each loss. Such insurance shall assure the restoration of any Plans, drawings, computations, field notes, or other similar data relating to the Work and/or the Project in the event of loss or destruction until all such items and data are turned over to the Mobility Authority. Such insurance may be provided separately or as part of the DB Contractor's Builder's Risk policy.

10.3 General Insurance Requirements

10.3.1 Premiums, Deductibles and Self-Insured Retentions

The DB Contractor shall be responsible for payment of premiums for all insurance required under this Section 10. The DB Contractor shall be solely responsible for all other deductibles and self-insured retentions hereunder. The DB Contractor further agrees that for each claim, suit or action made against insurance provided hereunder, with respect to all matters for which the DB Contractor is responsible hereunder, the DB Contractor shall be solely responsible for amounts in

excess of the coverage provided. With respect to all matters for which the Mobility Authority is responsible hereunder, the Mobility Authority shall remain fully responsible for amounts in excess of the coverage provided.

10.3.2 Verification of Coverage

(a) The DB Contractor Policies. Concurrently with the date on which coverage is required to be procured under this Section 10, the DB Contractor will deliver to the Mobility Authority original certificates of insurance, which shall be completed by an agent authorized to bind the named underwriter(s) and their company to the coverage, limits and termination provisions shown thereon, and which shall furnish and contain all required information referenced or indicated thereon. The original certificate(s) must have the agent's original signature, including the signer's company affiliation, title and phone number, and be mailed directly from the agent to the Mobility Authority. The Mobility Authority shall have no duty to pay or perform under this DB Agreement until such certificate(s) shall have been delivered to the Mobility Authority. Upon the Mobility Authority's request, duplicate copies of each of the insurance policies (including all endorsements and amendments) required under Section 10 shall be provided to the Mobility Authority; provided that where the DB Contractor is permitted to provide certain coverages through its corporate program, instead of providing copies, the DB Contractor may make such policies available for inspection by the Mobility Authority at the DB Contractor's corporate offices.

(b) Renewal Policies. When applicable, not less than 30 Days prior to the expiration date of any policy of insurance required by this Section 10, the DB Contractor shall deliver to the Mobility Authority a binder or certificate of insurance with respect to each renewal policy. If requested by the Mobility Authority from time to time, certified duplicate copies of the renewal policy shall also be provided; provided that where the DB Contractor is permitted to provide certain coverages through its corporate program, instead of providing copies, the DB Contractor may make such policies available for inspection by the Mobility Authority at the DB Contractor's corporate offices.

10.3.3 Subcontractor Insurance Requirements

The DB Contractor shall cause each Subcontractor to provide insurance that complies with requirements for the DB Contractor-provided insurance set forth in this Section 10 in circumstances where the Subcontractor is not covered by the DB Contractor-provided insurance and provided that the DB Contractor shall have sole responsibility for determining the limits of coverage required to be obtained by Subcontractors, which determination shall be made in accordance with reasonable and prudent business practices. The DB Contractor shall cause each such Subcontractor to include each of the Indemnified Parties as additional insureds on a primary and non-contributory basis, under such Subcontractor's commercial general liability, umbrella excess liability, and business automobile liability insurance policies. The DB Contractor shall require each such Subcontractor to require that its insurer agree to waive any subrogation rights the insurers may have against the Indemnified Parties. The Mobility Authority shall have the right to contact the Subcontractors directly in order to verify the above coverage.

10.3.4 Endorsements and Waivers

All insurance policies required to be provided by the DB Contractor hereunder shall contain or be endorsed to contain the following provisions, provided that, for the workers' compensation policy and the professional liability policy, only the following *clause (d)* shall be applicable:

(a) For claims covered by the insurance specified herein, said insurance coverage shall be primary insurance with respect to the insureds and additional insureds and shall specify that coverage continues notwithstanding the fact that the DB Contractor has left the Site. Any insurance or self-insurance beyond that specified in this DB Agreement that is maintained by an insured or additional insured shall be excess of such insurance and shall not contribute with such primary insurance.

(b) Any failure on the part of a named insured to comply with reporting provisions or other conditions of the policies, any breach of warranty, any action or inaction of a named insured or others, any foreclosure relating to the Project or any change in ownership of all or any portion of the Project shall not affect coverage provided to the other insureds or additional insureds.

(c) The insurance shall apply separately to each insured and additional insured against whom a claim is made or suit is brought, except with respect to the aggregate limits of the insurer's liability.

(d) Each policy shall be endorsed to state that coverage shall not be suspended, voided, canceled, modified or reduced in coverage or in limits except after 30 days' prior written notice has been given to the Mobility Authority and the DB Contractor. Such endorsement shall not include any limitation of liability of the insurer for failure to provide such notice.

(e) All Commercial General Liability endorsements adding additional insureds shall be on forms CG-20-10 (latest edition) or an equivalent form providing additional insureds with coverage for premises/operations and CG 2037 (or equivalent) for completed operations.

(f) Each policy shall provide coverage on an "occurrence" basis and not a "claims made" basis (with the exception of professional liability policies).

10.3.5 Waivers and Subrogation

The Mobility Authority and the DB Contractor waive all rights against each other, against each of their agents and employees and their respective members, directors, officers, employees, agents and consultants for any claims, but only to the extent covered by insurance obtained pursuant to this *Section 10*, except such rights as they may have to the proceeds of such insurance and provided further that the DB Contractor shall not be entitled to additional compensation or time extension under this DB Agreement to the extent compensated by any insurance specified herein. The DB Contractor shall cause all Subcontractors to provide similar waivers in writing each in favor of all other parties enumerated above. Each policy shall include a waiver of any right of subrogation against the additional insureds (and their respective members, directors, officers, employees, agents and consultants).

10.3.6 Changes in Requirements

The Mobility Authority shall notify the DB Contractor in writing of any changes in the requirements applicable to insurance required to be provided by the DB Contractor. Pursuant to a Change Order, any additional cost from such change shall be paid by the Mobility Authority and any reduction in cost shall reduce the DB Price.

10.3.7 No Recourse

There shall be no recourse against the Mobility Authority for payment of premiums or other amounts with respect to the insurance required to be provided by the DB Contractor hereunder.

10.3.8 Support of Indemnifications

The insurance coverage provided hereunder by the DB Contractor is not intended to limit the DB Contractor's indemnification obligations under Section 23.

10.3.9 Commercial Unavailability of Required Coverages

If, in the future, through no fault of the DB Contractor, any of the coverages required in this Section 10 (or any of the required terms of such coverages, including endorsements and/or policy limits) are not available or become in the future unavailable as determined under a commercial reasonableness standard, the Mobility Authority will work with the DB Contractor to find commercially reasonable alternatives to the required coverages that are acceptable to the Mobility Authority and to the DB Contractor. In the event any required coverage is not available and no reasonable alternative is acceptable, the Mobility Authority shall be entitled to a Change Order to reduce the DB Price by the cost of any required insurance that is not obtained due to commercial unavailability.

10.4 Mobility Authority's Right to Remedy Breach by the DB Contractor

If the DB Contractor or any Subcontractor fails to provide insurance as required herein, the Mobility Authority shall have the right, but not the obligation, to purchase such insurance. In such event, the amounts paid by the Mobility Authority shall, at the Mobility Authority's sole option, be deducted from amounts payable to the DB Contractor or reimbursed by the DB Contractor upon demand, with interest thereon at the maximum rate allowable under applicable Law from the date of payment by the Mobility Authority. Nothing herein shall preclude the Mobility Authority from exercising its rights and remedies under Section 17 as a result of the failure of the DB Contractor or any Subcontractor to satisfy the obligations of this Section 10.

10.5 Other Conditions

10.5.1 Minimum Safety Compliance Requirements

The DB Contractor shall be solely responsible for safety on the Site, and shall comply in all respects with the Safety Plan. Each Subcontractor, before performing any Work, shall agree in writing to, and shall when performing any Work, comply with the requirements of the Safety Plan. Any suspension of Work by the Mobility Authority related to safety concerns, including the failure of any member of the DB Contractor Group to comply with the Safety Plan, shall be considered a suspension for cause under Section 15.2.

10.5.2 Due Care Required

Nothing contained in this Section 10 shall relieve the DB Contractor or any Subcontractors of its obligation to exercise due care in the performance of the Work and to complete the Work in strict compliance with this DB Agreement.

10.6 Prosecution of Claims

Unless otherwise directed by the Mobility Authority in writing, the DB Contractor shall report and process all potential claims by the Mobility Authority or the DB Contractor against the insurance required to be provided hereunder. The DB Contractor agrees to report timely to the insurer(s) any and all matters which may give rise to an insurance claim and to promptly and diligently pursue any and all insurance claims on behalf of the Mobility Authority, whether for defense or indemnity or both. The Mobility Authority agrees to notify the DB Contractor of the Mobility Authority's incidents, potential claims, and matters which may give rise to an insurance claim by the Mobility Authority, to tender its defense or the claim to the DB Contractor, and to reasonably cooperate with the DB Contractor for the DB Contractor to fulfill its duties hereunder.

10.7 Commencement of Work

The DB Contractor shall not commence Work under this DB Agreement until it has obtained the applicable insurance required under this Section 10 and such insurance has been approved by the Mobility Authority. The DB Contractor shall not allow any Subcontractor to commence work under its Subcontract until the insurance required of the Subcontractor has been obtained and approved by the DB Contractor. If the insurance provided by the DB Contractor fails to comply with the requirements listed herein, or if the DB Contractor fails to maintain such insurance, then the Mobility Authority maintains the right to suspend the DB Contractor's right to proceed until the Mobility Authority receives satisfactory evidence that the required insurance coverage has been procured in accordance with the terms hereof.

10.8 Disclaimer

The DB Contractor and each Subcontractor have the responsibility to make sure that their insurance programs fit their particular needs, and it is their responsibility to arrange for and secure any insurance coverage which they deem advisable, whether or not specified herein.

10.9 Insurance During Warranty Period

During the period following Final Acceptance and prior to expiration of the DB Contractor's Warranty, the DB Contractor shall make available all insurance as specified in Section 10.2, excluding builder's risk coverage, which coverage shall be reinstated by the DB Contractor in the event of, and prior to the commencement of any required Warranty Work by the DB Contractor.

11. SITE SECURITY; RESPONSIBILITY FOR LOSS OR DAMAGE

11.1 Site Security

The DB Contractor shall provide appropriate security for the Site, and shall take all reasonable precautions and provide protection to prevent damage, injury, or loss to the Work and materials and equipment to be incorporated therein, as well as all other property at or on the Site, whether owned by the DB Contractor, the Mobility Authority, or any other Person.

11.2 Risk of Loss or Damage; Maintenance and Repair of Work

The Work includes maintenance throughout the entire period from the DB Contractor's placement of barricades anywhere for the Project until Final Acceptance in accordance with *Technical Provision 24*. In addition to such routine maintenance, the DB Contractor, at no additional cost to the Mobility Authority, shall maintain, rebuild, repair, restore or replace all Work, including Design Documents, Construction Documents, materials, equipment, supplies and maintenance equipment which are purchased for permanent installation in, or for use during construction of the Project that is injured or damaged prior to Substantial Completion, regardless of who has title thereto under the Contract Documents and regardless of the cause of the damage or injury, except to the extent that (a) the Mobility Authority is responsible for such costs in accordance with the terms of this DB Agreement, (b) control of such improvements has transferred to third parties (other than the Mobility Authority), or (c) the DB Contractor retains responsibility for loss and control of certain elements of the Project beyond Final Acceptance. The DB Contractor, at its cost and on the same conditions, shall also have sole responsibility during such periods for rebuilding, repairing and restoring all other property within the Final ROW whether owned by the DB Contractor, the Mobility Authority or any other Person. If insurance proceeds with respect to any loss or damage are paid to the Mobility Authority, then the Mobility Authority shall arrange for such proceeds to reimburse the DB Contractor as repair or replacement work is performed by the DB Contractor to the extent that the Mobility Authority has not previously paid for such repair or replacement work; provided, however, that release of such proceeds to the DB Contractor shall not be a condition precedent to the DB Contractor's obligation to perform such replacement or repair work or indicate that such replacement or repair work has been approved and accepted by the Mobility Authority. Notwithstanding this *Section 11.2* or any other provision of this DB Agreement, the DB Contractor shall be entitled to a Change Order for any unreimbursed costs it incurs related to repairs resulting from the actions of any third parties that exceed \$300,000 in the aggregate. In no event shall the DB Contractor be entitled to a Change Order to extend the Completion Deadline related to its obligations under this *Section 11.2*.

12. WARRANTIES

12.1 Warranties

12.1.1 The warranties set forth in *Sections 12.1.1.1* and *12.1.1.2* shall individually be referred to herein as a "**Warranty**" and, collectively, as the "**Warranties**".

12.1.1.1 The DB Contractor Warrants that for Design Work:

(a) all professional engineering services performed pursuant to the Contract Documents shall conform to all professional engineering principles generally accepted as standards of the industry in the State at the time the services are performed;

(b) the Project shall be free of errors or omissions that would not be committed by an ordinarily prudent engineer and shall be free of Deviations not previously approved by the Mobility Authority in accordance with the Contract Documents;

(c) the Work shall be designed so as to not require significant or unusual maintenance, including landslide/rock removal, drainage repair and mud removal due to erosion; and

(d) the Work shall meet all of the requirements of the Contract Documents.

12.1.1.2 The DB Contractor Warrants for Construction Work:

(a) each of the Warranty specifications set forth in Section 3.4 of Technical Provision 3; and

(b) the Work shall meet all of the requirements of the Contract Documents.

12.1.1.3 Except as provided in Section 12.1.1.1 and 12.1.1.2, the DB Contractor makes no other warranties or guarantees, express or implied, with respect to the quality of the Work. IMPLIED WARRANTIES, INCLUDING BUT NOT LIMITED TO WARRANTIES OF MERCHANTABILITY AND FITNESS FOR A PARTICULAR PURPOSE, ARE SPECIFICALLY DISCLAIMED AND EXCLUDED.

12.1.2 The Warranties for the Project shall commence upon Final Acceptance for the remaining Work, and shall remain in effect until the time specified in Technical Provision 3 with respect to each of the general conditions set forth in such Technical Provision 3. If the Mobility Authority determines that any of the Work has not met the standards set forth in this Section 12.1 and Technical Provision 3 at any time during the warranty period for such Work, then the DB Contractor shall correct such Work as specified in Technical Provision 3, even if the performance of such corrective work extends beyond the stated warranty period.

12.1.3 If the DB Contractor does not use its Best Efforts to effectuate a remedy within the agreed time, as set forth in Technical Provision 3, then the Mobility Authority shall have the right to perform or have performed by third parties the necessary remedy, and the Mobility Authority shall, at its option, deduct from any moneys due or to become due the DB Contractor and/or obtain reimbursement from the DB Contractor for such cost, with interest thereon from the date of the Mobility Authority's disbursement until payment is received by the Mobility Authority at the lesser of (i) 12% per annum or (ii) the maximum amount allowable under applicable Law.

12.1.4 All costs of repairing, replacing or correcting Work pursuant to the Warranties, including additional testing and inspections, shall be deemed included in the DB Price. Should the DB Contractor fail to submit within five (5) Days following written notice from the Mobility Authority a reasonable work plan evidencing the DB Contractor's commitment to promptly begin

performance of Warranty work as directed by the Mobility Authority, and the Mobility Authority is required to perform the same, the DB Contractor shall reimburse the Mobility Authority for all expenses, direct and indirect, incurred by the Mobility Authority as a result of such Warranty work, including any costs incurred by the Mobility Authority for independent quality assurance and/or quality control with respect to the Warranty work, within ten Days after the DB Contractor's receipt of invoices therefor (including, subject to the \$10,000,000 limitation in Section 18.3.1(c), any lost toll revenue arising from or relating to such repair, replacement or corrective work) with interest thereon from the date such costs are incurred by the Mobility Authority until payment is received by the Mobility Authority at the lesser of (i) 12% per annum or (ii) the maximum amount allowable under applicable Law. Alternatively, the Mobility Authority may, at its option, deduct such sums from any moneys due or to become due the DB Contractor. Any dispute relating to this Section 12 shall be subject to the dispute resolution provisions contained in Section 25 of this DB Agreement, provided that the DB Contractor shall proceed as directed by the Mobility Authority pending resolution of the dispute.

12.1.5 The Mobility Authority will notify the DB Contractor when action is required to address a condition that it has determined to be unsafe, and the DB Contractor must make immediate emergency repairs. However, if the DB Contractor is unavailable or unable to comply with this requirement to the Mobility Authority's satisfaction and within the time frame required by the Mobility Authority, the Mobility Authority will perform, or have performed, any necessary emergency repairs. Any such emergency repairs undertaken will not relieve the DB Contractor from the obligation to meet the Warranty requirements. If the unsafe condition is determined by the Mobility Authority to have been caused by defective materials and/or workmanship, then any cost associated with the emergency repair shall be paid by the DB Contractor. In the event the DB Contractor fails to pay such cost within 30 days of receipt of notice for payment, the Mobility Authority will be entitled to recover the costs of such Work from the Warranty Bond.

12.1.6 The procedures, processes, tests, inspections, materials, equipment, machinery, personnel and other actions and items utilized or required under this DB Agreement with respect to the Work shall apply equally to any repaired, replaced or corrected Work.

12.2 Applicability of Warranties to Repaired, Replaced, or Corrected Work

The Warranties shall apply to all Work repaired, replaced or corrected pursuant to the terms of this DB Agreement. The Warranties for repaired, replaced or corrected Work shall apply for the longer of (i) the remainder of the Warranty term or (ii) one (1) year from the date of acceptance by the Mobility Authority of the repaired, replaced or corrected Work.

12.3 Subcontractor and Extended Warranties

12.3.1 Without in any way derogating the Warranties and the DB Contractor's other obligations with respect to the Work, the DB Contractor shall obtain from all Subcontractors and cause to be extended to the Mobility Authority, for periods at least coterminous with the Warranties, appropriate representations, warranties, guarantees and obligations with respect to design, materials, workmanship, equipment, tools, supplies and other aspects of the Work furnished by such Subcontractors. All representations, warranties, guarantees and obligations of Subcontractors (a) shall be written so as to survive all inspections, tests and approvals hereunder, and (b) shall run directly to and be enforceable by the DB Contractor, the Mobility Authority

and/or their respective successors and assigns. The DB Contractor assigns to the Mobility Authority all of the DB Contractor's rights and interest in all extended warranties for periods exceeding the applicable Warranty period which are received by the DB Contractor from any of its Subcontractors. To the extent that any Subcontractor or Supplier warranty or guaranty would be voided by reason of the DB Contractor's negligence in incorporating material or equipment into the work, the DB Contractor shall be responsible for correcting such defect.

12.3.2 Upon receipt from the Mobility Authority of notice of a failure of any Work performed by a Subcontractor to satisfy the requirements of the Contract Documents, the DB Contractor shall enforce or perform any such Subcontractor representation, warranty, guaranty or obligation, in addition to the DB Contractor's other obligations hereunder. The Mobility Authority's rights under this Section 12.3.2 shall commence at the time such representation, warranty, guaranty or obligation is furnished and shall continue until the expiration of the Warranties (including extensions thereof under Section 12.2). Until such expiration, the cost of any equipment, material, labor (including re-engineering) or shipping shall be at the DB Contractor's cost if such cost is covered by such a Subcontractor representation, warranty, guaranty or obligation and the DB Contractor shall be required to replace or repair defective equipment, material or workmanship furnished by Subcontractors.

12.3.3 The foregoing provisions concerning Subcontractor warranties are intended to provide the Mobility Authority with an additional Person and source in which to seek recourse if Work fails to meet the requirements of the Contract Documents. In no event shall the foregoing provisions be interpreted to modify, limit, discharge, release, negate or waive the Warranties or the DB Contractor's obligations with respect to the Work, and the DB Contractor shall not be entitled to use the existence of Subcontractor warranties as a defense to the DB Contractor's obligations under this DB Agreement and the other Contract Documents.

12.4 Effect of the Mobility Authority or Maintenance Contractor Activities on Warranties

The DB Contractor acknowledges and agrees that the Mobility Authority, TxDOT, or a maintenance contractor hired by the Mobility Authority or TxDOT and their respective agents may perform certain maintenance work during the period in which the Warranties are in effect and agrees that the Warranties shall apply notwithstanding such activities; provided that, the foregoing shall not be deemed to require the DB Contractor to repair, replace or correct problems to the extent caused by the Mobility Authority, TxDOT, a maintenance subcontractor hired by the Mobility Authority or TxDOT, or defective maintenance.

12.5 No Limitation of Liability

Subject to Section 12.1.1.3, the Warranties are in addition to all rights and remedies available under the Contract Documents or applicable Law or in equity, and shall not limit the DB Contractor's liability or responsibility imposed by the Contract Documents or applicable Law or in equity with respect to the Work, including liability for design defects, latent construction defects, strict liability, breach, negligence, willful misconduct or fraud; provided, however, that upon expiration of the Warranties, the DB Contractor shall have no further liability to the Mobility Authority for latent construction defects, unless the Mobility Authority has initiated a lawsuit for

such latent defects within the applicable Warranty period or the applicable statute of limitations period under State law if such period is longer than the Warranty period.

12.6 Damages for Breach of Warranty

If the DB Contractor fails or refuses to satisfy its obligations with respect to the Warranties, then, in addition to the Mobility Authority's other rights and remedies hereunder, at Law or in equity, the DB Contractor shall be liable for the cost of performance of such obligations by others, with interest thereon at the lesser of (i) 12% per annum or (ii) the maximum rate allowable by applicable Law.

12.7 Warranty Beneficiaries

In addition to benefiting the Mobility Authority, and its successors and assigns, the Warranties and Subcontractors' warranties provided under this *Section 12* shall inure to the benefit of and shall be directly enforceable by local agencies and Utility Owners, with respect to their facilities.

12.8 Transfer of Warranties to TxDOT

DB Contractor acknowledges that, pursuant to the PDA between the Mobility Authority and TxDOT, ownership of the general purpose lanes and frontage roads included in the Project, together with all rights of the Mobility Authority with respect to the enforcement of the Warranties described in this *Section 12* and in *Technical Provision 3* related to such general purpose lanes and frontage roads, will be transferred by the Mobility Authority to TxDOT following Final Acceptance of the Project hereunder. The DB Contractor hereby consents to such transfer of such Warranties and agrees that it shall be obligated to comply with all Warranty provisions under the Contract Documents, upon the terms and for the time periods specified herein, and that TxDOT shall be entitled to all rights of the Mobility Authority hereunder to enforce such Warranties.

13. PAYMENT

13.1 DB Price

Subject to *Sections 13.2, and 13.5*, as full compensation for the Work and all other obligations to be performed by the DB Contractor under the Contract Documents, the Mobility Authority shall pay to the DB Contractor a lump sum of **\$477,149,654**. Such sum, as it may be adjusted from time to time to account for Change Orders, is referred to herein as the "**DB Price**".

13.1.1 The DB Price shall be paid in accordance with *Section 13.3* and may be changed only by a Change Order issued in accordance with *Section 14*, or Liquidated Damages pursuant to *Section 18.1*. The DB Contractor acknowledges and agrees that, subject only to the DB Contractor's rights under *Section 14*, the DB Price includes (a) all designs, equipment, materials, labor, insurance and bond premiums, home office, jobsite and all other overhead, profit and services related to the DB Contractor's performance of its obligations under the Contract Documents, including all Work, equipment, materials, labor and services provided by Subcontractors and all intellectual property rights necessary to perform the Work; (b) performance of each and every portion of the Work; (c) the cost of obtaining all Governmental Approvals and compliance with such Governmental Approvals and applicable Law; and (d) payment of any duties

and other fees, costs and/or royalties imposed with respect to the Work and any equipment, materials, labor or services included therein.

13.2 NTP1 and NTP2 Work Payments; Delay in Issuance of NTP1 and/or NTP2

13.2.1 NTP1 and NTP2 Work Payments

13.2.1.1 The DB Contractor acknowledges and agrees that (i) the Mobility Authority will not pay for NTP1 Work prior to issuance of the NTP1, (ii) except for NTP1 Work, the Mobility Authority will not pay for any other Work prior to issuance of NTP2, (iii) any NTP1 Work performed by the DB Contractor prior to the issuance of NTP1 and any other Work performed by the DB Contractor prior to issuance of NTP2 shall, therefore, be performed solely at the DB Contractor's risk and (iv) the Mobility Authority shall have no liability hereunder and no responsibility to pay the DB Contractor for any Work performed by the DB Contractor unless and until the subject NTP is issued by the Mobility Authority, in its sole discretion.

13.2.2 Delay in Issuance of NTP1, NTP2, and NTP3; Escalation

13.2.2.1 The Mobility Authority intends to issue NTP1 following the Finance Closing Date, which will authorize the DB Contractor to proceed with the NTP1 Work. The Mobility Authority intends to issue NTP2 for the remaining Work following the Finance Closing Date. If NTP1 and NTP2 have not been issued by the Mobility Authority as of 210 Days after the Proposal Date, due to no fault of any member of the DB Contractor Group, this DB Agreement shall remain in full force and effect, without any modification to the terms and conditions hereof, provided that the DB Contractor shall be entitled to an adjustment in the DB Price for the Work, based on the Engineering News Record Construction Cost Index for Construction Costs ("ENR CCI"), from a base date commencing as of the expiration of such 210 Day period and until the date of issuance of NTP calculated as follows:

$$\text{Adjusted DP} = (\text{Proposal DP}) \times (\text{ENR CCI}) / (\text{BI})$$

The Base Index (BI) is the Engineering News Record Construction Cost Index for the calendar month which occurs 210 Days after the Proposal Date. The ENR CCI is the Engineering News Record Construction Cost Index for the month in which NTP2 is issued.

13.2.2.2 If NTP1 and NTP2 have not been issued as of 365 Days after the Proposal Date due to no fault of any member of the DB Contractor Group, the DB Contractor may seek to negotiate a Change Order, including an extension in time for issuance of NTP1 and/or NTP2 and an increase in the DB Price mutually acceptable to the DB Contractor and the Mobility Authority, provided that any extension in time for issuance of NTP2 beyond 365 Days after the Proposal Date shall be subject to the concurrence of Surety. If the DB Contractor does not wish to seek a Change Order as provided above or the Mobility Authority fails to issue a Change Order acceptable to the DB Contractor, then following 365 Days after the Proposal Date, the DB Contractor's sole remedy shall be to terminate this DB Agreement by delivery of notice of termination to the Mobility Authority.

13.2.2.3 If NTP2 has not been issued within 90 Days after the date of issuance of NTP1 through no fault of any member of the DB Contractor Group, the DB Contractor may be entitled to a Change Order to extend the Completion Deadline to the extent the DB

Contractor can demonstrate that the failure to issue NTP2 within such time period adversely affected the DB Contractor's Critical Path.

13.2.2.4 In the event the Mobility Authority issues NTP3, and if NTP3 has not been issued within 30 Days after the date of issuance of NTP2 through no fault of any member of the DB Contractor Group, the DB Contractor may be entitled to a Change Order to extend the Completion Deadline to the extent the DB Contractor can demonstrate that the failure to issue NTP3 within such time period adversely affected the DB Contractor's Critical Path. If NTP1 and NTP2 have been issued but NTP3 has not been issued as of 90 Days after the issuance of NTP2 due to no fault of any member of the DB Contractor Group, the DB Contractor or the Mobility Authority may seek to negotiate a Change Order, including an extension in time for issuance of NTP3 and a change in the DB Price mutually acceptable to the DB Contractor and the Mobility Authority.

13.3 Payments

Payment to the DB Contractor of the DB Price shall be made in accordance with the procedures set forth in this Section 13.3.

13.3.1 Delivery of Draw Request

On or about the fifth Business Day of each month, the DB Contractor shall deliver to the Mobility Authority five copies of a Draw Request in the form attached hereto as Exhibit L and meeting all requirements specified herein except as otherwise approved in writing by the Mobility Authority. Each Draw Request shall be executed by a designated and authorized representative of the DB Contractor appointed by the DB Contractor to have such authority in accordance with this DB Agreement. The DB Contractor acknowledges that the Mobility Authority will obtain funding for portions of the Work from the federal government, local agencies, the DB Contractor, if applicable, and other third parties, and the DB Contractor agrees to segregate Draw Requests for all such Work in a format reasonably requested by the Mobility Authority and with detail and information as reasonably requested by the Mobility Authority. Each Draw Request shall be organized to account for applicable reimbursement requirements and to facilitate the reimbursement process.

13.3.2 Contents of Draw Request

Each Draw Request must contain the following items:

- (a) Draw Request cover sheet;
- (b) Monthly progress report as described in Technical Provision 1;
- (c) Certification by the Design Quality Assurance Manager and the Construction Quality Assurance Manager that all Work which is the subject of the Draw Request fully complies with the requirements of the Contract Documents subject to any exceptions identified in the certification;
- (d) Draw Request data sheet(s) and supporting documents, as required by the Mobility Authority to support and substantiate the amount requested (based on quantities and unit

prices for unit priced Work, based on time and materials for Time and Materials Change Orders, based on actual costs as evidenced by invoices for items to be paid from an allowance, and based on the Project Schedule of Values for all other Work);

- (e) DBE utilization report in a format reasonably satisfactory to the Mobility Authority;
- (f) Cash flow curves and comparison to the Payment Curve;
- (g) A Mobility Authority accepted Project Status Schedule Update in accordance with Section 5 hereof and Technical Provision 5. Acceptance of the Project Status Schedule Update is required prior to submittal of the Draw Request;
- (h) A waiver of lien from each applicable Subcontractor that was scheduled to be paid pursuant to the previous month's Draw Request;
- (i) Certified invoices for materials on hand in accordance with Section 13.3.13;
- (j) A Debarment Certificate in the form of Exhibit P hereto.
- (k) Such other items as the Mobility Authority reasonably requests.

In addition, no Draw Request shall be considered complete unless it: (1) describes in detail the status of completion as it relates to the Project Schedule; (2) sets forth in detail the related payments which are then due in accordance with the Project Schedule of Values, as of the end of the prior month; (3) in the case of amounts to be paid on a unit price basis, includes invoices, receipts or other evidence establishing the number of units delivered; (4) in the case of amounts invoiced on a time and materials basis, includes all supporting documentation described in Section 14.7; and (5) sets forth in detail the amounts paid to Subcontractors (including Suppliers and sub-subcontractors) from the payments made by the Mobility Authority to the DB Contractor with respect to the prior month's Draw Request, including executed unconditional waivers of claims with respect to all amounts so paid.

13.3.3 Draw Request Cover Sheet Contents

The Draw Request cover sheet shall include the following:

- (a) Project number and title;
- (b) Request number (numbered consecutively starting with "1");
- (c) Total amount earned to date for the Project as a whole in order to allow the Mobility Authority to calculate, withhold, deposit, or release Retainage in accordance with the terms hereof; and
- (d) Authorized signature, title of signer, and date of signature.

13.3.4 Certification by Design Quality Assurance Manager and Construction Quality Assurance Manager

With each Draw Request, the DB Contractor shall submit a certificate in the form attached hereto as Exhibit L and signed by the Design Quality Assurance Manager (“DQAM”) and Construction Quality Assurance Manager (“CQAM”), certifying that:

(a) All Work, including that of designers, Subcontractors, including Suppliers and fabricators, which is the subject of the Draw Request has been checked and/or inspected by the DQAM and the CQAM;

(b) Except as specifically noted in the certification, all Work which is the subject of the Draw Request conforms to the requirements of the Contract Documents, the Governmental Approvals and applicable Law;

(c) The DQMP and the CQMP and all of the measures and procedures provided therein are functioning properly and are being followed in all respects; and

(d) The design and construction quantities, percentages and cost indicated are accurate and correct.

13.3.5 [Reserved]

13.3.6 Draw Request Data Sheets

Draw Request data sheets shall be subdivided into the DB Contractor-designated Project segments and shall be attached to a Project-wide report and Draw Request data sheet. It is the intent of the Mobility Authority to base payments on a mutually agreed estimate of percentage of Work completed, not on measured quantities, except that cost plus or unit price Change Order work or items to be paid from an allowance may be paid based upon measured quantities. The DB Contractor’s designation of activities, phases and Project segments and their representation on the final approved Project Schedule and the corrected monthly progress reports shall facilitate this basis of determining periodic payments. Where progress is measured by percentage complete and days remaining, the percentage shall be calculated using Primavera P8.3. The DB Contractor may present the format of the Draw Request data sheets for Mobility Authority approval at least twenty (20) Business Days prior to the submittal of the first Draw Request. Once the Draw Request format has been approved by the Mobility Authority, the format shall not change without prior written approval of the Mobility Authority.

13.3.7 Payment by the Mobility Authority

Within fifteen (15) Business Days after the Mobility Authority’s receipt of a complete Draw Request, the Mobility Authority will review the Draw Request and all attachments and certificates thereto for conformity with the requirements of the Contract Documents, and shall notify the DB Contractor of the amount approved for payment and the reason for disapproval of any remaining invoiced amounts or of any other information set forth in the Draw Request. The DB Contractor may include such disapproved amounts in the next month’s Draw Request after correction of the deficiencies noted by the Mobility Authority. All such disapproved amounts shall be deemed in dispute unless otherwise agreed. Within thirty (30) Business Days after submittal

of a Draw Request in conformity with the requirements of the Contract Documents, the Mobility Authority shall pay the DB Contractor the amount of the Draw Request approved for payment less any applicable Retainage and less any amounts which the Mobility Authority is otherwise entitled to withhold or deduct. In no event shall the DB Contractor be entitled to (a) payment for any activity in excess of the value of the activity times the completion percentage of such activity (for non-unit priced Work), or (b) aggregate payments hereunder in excess of the overall completion percentage for the Project times the DB Price (for non-unit-priced Work). Interest on late payments to the DB Contractor shall accrue and be paid thereon at the rate equal to the lesser of (i) 12% per annum or (ii) the maximum rate allowable under applicable Law.

13.3.8 Payment to Subcontractors

The DB Contractor shall promptly pay each Subcontractor for Work no later than ten (10) Days after receipt of payment for such Work from the Mobility Authority, the amount to which such Subcontractor is entitled, less any retainage provided for in the Subcontract, as well as any other offsets and deductions provided in the Subcontract or by Law. The DB Contractor further agrees to pay retainage to each Subcontractor within ten (10) Days after the Subcontractor's work is satisfactorily completed. For the purpose of this Section 13.3.8, satisfactory completion shall have been accomplished when:

(a) The Subcontractor has fulfilled the Subcontract requirements and the requirements under the Contract Documents for the subcontracted Work, including the submission of all submittals required by the Subcontract and Contract Documents; and

(b) The Work performed by the Subcontractor has been inspected and approved in accordance with the Contract Documents and the final quantities of the Subcontractor's work have been determined and agreed upon.

The inspection and approval of a Subcontractor's work does not eliminate or impair the DB Contractor's responsibility for the Work under this DB Agreement. Any delay or postponement of payments to Subcontractors from the above-referenced time frames may occur only for good cause following written approval by the Mobility Authority. The DB Contractor shall, by appropriate agreement with each Subcontractor, require each Subcontractor to make payments to sub-subcontractors in a similar manner. The Mobility Authority shall have no obligation to pay a Subcontractor. Interest on late payments to Subcontractors shall be the DB Contractor's responsibility, and shall not be a part of the DB Price. The foregoing payment requirements apply to all tiers of Subcontractors and shall be incorporated by the DB Contractor into all Subcontracts.

13.3.9 Continued Performance During Disputes

Failure by the Mobility Authority to pay any amount in dispute shall not postpone, alleviate, diminish, release, alter or modify in any respect the DB Contractor's obligation to perform under the Contract Documents, including the DB Contractor's obligation to achieve Substantial Completion by the Completion Deadline, to achieve Final Acceptance by the Acceptance Deadline and to complete all Work in accordance with the Contract Documents, and the DB Contractor shall not cease or slow down its performance under the Contract Documents on account of any such dispute. Notwithstanding the foregoing, Mobility Authority shall be required

to submit payment of those amounts not in dispute and/or approved for payment. Any dispute regarding such payment shall be resolved pursuant to Section 25 of this DB Agreement. Upon resolution of any such dispute, subject to the limitations specified in this Section 13, the Mobility Authority shall promptly pay to the DB Contractor any amount identified through the dispute resolution process as owing to the DB Contractor. If payment of disputed amounts is made after the 30th Day following the proper submission of a complete Draw Request, then the payment shall, subject to the limitations specified in this Section 13, include interest on the amount owing, from the date that the payment was due (based on the agreement of the Parties or the decision of the judge) until the date of payment, which shall accrue at the rate equal to the lesser of (i) 12% per annum or (ii) the maximum rate allowable under applicable Law.

13.3.10 **Retainage**

13.3.10.1 The Mobility Authority shall not withhold funds as retainage from payments to be made to the DB Contractor for the Work until such time as 98% of the Work has been completed and payment therefor has been made to the DB Contractor. Following completion of and payment for 98% of the Work, the Mobility Authority shall withhold, as retainage (the "**Retainage**"), the remaining 2% of the DB Price pursuant to the terms described below.

13.3.10.2 The Retainage for Work, subject to reduction as specified below, shall be held by the Mobility Authority until 60 Days after Final Acceptance of the Project. At such time, and provided that the DB Contractor is not in breach or default hereunder, the Mobility Authority shall release to the DB Contractor all Retainage withheld in connection with Work other than amounts applied to the payment of Losses or which the Mobility Authority deems advisable, in its sole discretion, to retain to cover any existing or written threatened claims, Liens and stop notices relating to the Project, including claims by Utility Owners and any railroad, the cost of any uncompleted Work and/or the cost of repairing any Nonconforming Work. Final payment of such Retainage not applied to Losses shall be made upon the DB Contractor's showing, to the Mobility Authority's satisfaction, that all such matters have been resolved, including delivery to the Mobility Authority of a certification representing and warranting that there are no outstanding claims of the DB Contractor or any claims, Liens or stop notices of any Subcontractor or laborer with respect to the Work.

13.3.10.3 Prior to the release of any Retainage by the Mobility Authority pursuant to the terms hereof, such amounts shall be held by the Mobility Authority in a separate account. Upon the release of any Retainage, the DB Contractor shall not be entitled to any interest income that has accrued upon the amounts of Retainage released to the DB Contractor.

13.3.11 **Deductions**

In addition to the deductions provided for above, the Mobility Authority may deduct from each payment to the DB Contractor under this DB Agreement the following:

(a) Any Mobility Authority or third party claims or Losses for which the DB Contractor is responsible under the Contract Documents or any Liquidated Damages which have accrued as of the date of payment, except to the extent an insurance claim therefor has been accepted by the insurer without any reservation of rights to deny coverage;

(b) Any sums expended by the Mobility Authority in performing any of the DB Contractor's obligations under this DB Agreement which the DB Contractor has failed to perform, with interest thereon from the date on which the Mobility Authority expended such sums at the lesser of (i) 12% per annum or (ii) the maximum rate allowable under applicable Law;

(c) Any sums that are the subject of an NCR that is not resolved;

(d) Any existing or written threatened claims, Liens and stop notices of Subcontractors, laborers, Utility Owners and other third parties against the DB Contractor or against the Mobility Authority as a result of the actions or failure to act by the DB Contractor, relating to the Project;

(e) Any other sums which the Mobility Authority is entitled to recover from any member of the DB Contractor Group under the terms of this DB Agreement; and

(f) Any sums that are the subject of a Noncompliance Charge under *Exhibit Q*.

The failure by the Mobility Authority to deduct any of these sums from a payment to the DB Contractor shall not constitute a waiver of the Mobility Authority's right to recover such sums or to deduct such funds from future payments.

13.3.12 **[RESERVED]**

13.3.13 **Materials On Hand**

The Mobility Authority will not pay for any material not yet incorporated in the Work other than precast concrete, reinforcing steel, structural steel, precast concrete members, stone, gravel, sand or other non-perishable materials that will be permanently incorporated in the Work. Payment for such items will be made only if all of the following conditions have been met:

13.3.13.1 Material shall be delivered to the Site, or delivered to the DB Contractor and promptly stored by the DB Contractor at a location approved by the Mobility Authority in its sole discretion. Prior to inclusion of such materials in any invoice, the DB Contractor shall submit certified bills for such materials to the Mobility Authority. The Mobility Authority shall allow only such portion of the amount represented by these bills as in its opinion is consistent with the reasonable cost of such materials. If such materials are stored at any site not approved by the Mobility Authority, the DB Contractor shall accept responsibility for and pay all personal and property taxes that may be levied against the Mobility Authority by any state or subdivision thereof on account of such storage of such material. The Mobility Authority will permit the DB Contractor, at its own cost, to in good faith contest the validity of any such tax levied against the Mobility Authority in appropriate proceedings and in the event of any judgment or decree of a court, the DB Contractor agrees to pay same together with any penalty or other costs, relating thereto.

13.3.13.2 All such materials so accepted shall be and become the property of the Mobility Authority. The DB Contractor at its own cost shall promptly execute, acknowledge and deliver to the Mobility Authority proper bills of sale or other instruments in writing in a form acceptable to the Mobility Authority conveying and assuring to the Mobility Authority title to such material included in any invoice, free and clear of all Liens. The DB Contractor at its own cost

shall conspicuously mark such material as the property of the Mobility Authority, shall not permit such materials to become commingled with non-Mobility Authority-owned property and shall take such other steps, if any, as the Mobility Authority may require or regard as necessary to vest title to such material in the Mobility Authority free and clear of Liens.

13.3.13.3 Material included in an invoice but which is subsequently lost, damaged or unsatisfactory shall be deducted from succeeding invoices.

13.3.13.4 Payment for material furnished and delivered as indicated in this Section 13.3.13 will not exceed the amount paid by the DB Contractor as evidenced by a bill of sale supported by paid invoice. The Mobility Authority shall withhold Retainage from such payment as specified in Section 13.3.10.

13.3.14 **Materials Acceptance Testing**

The Mobility Authority will pay for costs associated with Materials Acceptance Testing (“MAT”). Any and all testing deemed to be considered QC materials testing shall be the responsibility of the DB Contractor.

13.3.15 **Mobilization**

The DB Contractor shall be entitled to mobilization payments in accordance with this Section 13.3.15 and Technical Provision 23. Payment for the cost of mobilization shall not exceed 10% of the DB Price. Payment for such mobilization will be made in three (3) payments as follows, but in no event earlier than the first progress payment after the issuance by the Mobility Authority of NTP1: (a) First Payment (25% of mobilization cost) will be paid with the first progress payment after the issuance by the Mobility Authority of NTP1; (b) Second Payment (50% of mobilization costs) will be paid when at least 5% of the DB Price (less mobilization and materials on hand) is earned; and (c) Final Payment (25% of mobilization costs) will be paid when at least 25% of the DB Price (less mobilization and materials on hand) is earned.

13.3.16 **Equipment**

The Mobility Authority will not pay for direct costs of equipment. Payment for equipment, whether new, used or rented, shall be allocated to and paid for as part of the mobilization payments allowed hereunder and/or as part of the compensation allowed for the activities with which the equipment is associated.

13.3.17 **Bond and Insurance Premiums**

The amount payable to the DB Contractor for bond and insurance premiums shall be a dollar-for-dollar pass through of the DB Contractor’s costs (not to exceed the line item for such premiums set forth in the Proposal), with any excess portion of the line item for such premiums set forth in the Proposal to be paid upon achievement of Substantial Completion of the Project and the opening of the Project.

13.4 Compensation for Early Completion

As an inducement to the DB Contractor to complete the items set forth in Section 20.1.1 (a) – (e) in advance of the original Completion Deadline, the Mobility Authority agrees to pay the DB Contractor a bonus for completing the items set forth in Section 20.1.1 (a) – (e) prior to the original Completion Deadline (the "**Incentive Payment**"), as follows:

13.4.1 If the items set forth in Section 20.1.1 (a) – (e) have occurred prior to the original Completion Deadline, the DB Contractor shall be entitled to receive \$50,000 per Day up to a capped amount of \$10,000,000 for all Incentive Payments payable for completing the items set forth in Section 20.1.1 (a) – (e).

13.4.2 Incentive Payments under Section 13.4.1 shall be paid by the Mobility Authority to the DB Contractor in accordance with the Draw Request provisions contained in Section 13.3 hereof. The Mobility Authority shall have the right to offset any amounts owing from the DB Contractor to the Mobility Authority against amounts payable under this Section 13.4.

13.4.3 If the Completion Deadline has been extended beyond the original deadline, and the DB Contractor achieves Substantial Completion prior to said extended deadline, the DB Contractor shall be entitled to receive Incentive Payment for Substantial Completion prior to such extended deadline and after the original Completion Deadline. The amount of such payment shall be calculated in accordance with Section 13.4.1 (replacing reference to the "original Completion Deadline" therein with reference to the "extended Completion Deadline" and shall be subject to the other provisions of this Section 13.4.

13.5 Final Payment

Final Payment for the Project will be made as follows:

13.5.1 On or about the date of Final Acceptance of the Project, the DB Contractor shall prepare and submit a proposed Final Draw Request to the Mobility Authority showing the proposed total amount due to the DB Contractor, including any amounts owing from Change Orders, for Work relating to the Project. In addition to meeting all other requirements for invoices hereunder, the Final Draw Request shall list all outstanding PCO Notices, stating the amount at issue associated with each such notice. The Final Draw Request shall be accompanied by (a) evidence regarding the status of all existing or written threatened claims, Liens and stop notices of Subcontractors, laborers, Utility Owners and railroads against the DB Contractor or against the Mobility Authority, (b) consent of any Guarantors and Surety to Final Payment, (c) such other documentation as the Mobility Authority may reasonably require; and (d) the release described in Section 13.5.4, executed by the DB Contractor. Prior applications and payments shall be subject to correction in the Final Draw Request. PCO Notices filed concurrently with the Final Draw Request must meet all requirements under Sections 14 and 25.

13.5.2 If the Final Draw Request shows no existing or written threatened claims, Liens and stop notices of Subcontractor, laborers, Utility Owners or railroads against the DB Contractor or against the Mobility Authority, and provided the Final Draw Request has been approved, the Mobility Authority, in exchange for an executed release meeting the requirements of Section 13.6.4 and otherwise satisfactory in form and content to the Mobility Authority, will pay

the entire sum found due on the approved Final Draw Request, less the amount of any Losses that have accrued as of the date of the Final Payment.

13.5.3 If the Final Draw Request lists any existing or written threatened claims, Liens and stop notices of Subcontractors, laborers, Utility Owners or railroads against the DB Contractor or against the Mobility Authority, or if any is thereafter filed, the Mobility Authority may withhold from the payment of the amounts set forth on the approved Final Draw Request such amount as the Mobility Authority deems advisable to cover any amounts owing to the Mobility Authority by the DB Contractor, including costs to complete or remediate uncompleted Work or Nonconforming Work, and the amount of any existing or threatened claims, Liens and stop notices of Subcontractors, laborers, Utility Owners and railroads against the DB Contractor or against the Mobility Authority.

13.5.4 The executed release from the DB Contractor shall be from any and all claims arising from the Work, and shall release and waive any claims against the Indemnified Parties, excluding only (i) those matters identified in any PCO Notices listed as outstanding in the Final Draw Request and (ii) any other disputes previously identified in writing to the Mobility Authority by the DB Contractor, provided such disputes are not otherwise by the Contract Documents required to be the subject of a PCO Notice. The release shall be accompanied by an affidavit from the DB Contractor certifying:

(a) That all Work has been performed in strict accordance with the requirements of the Contract Documents;

(b) That the DB Contractor has resolved any claims made by Subcontractors, Utility Owners, any railroad and others against the DB Contractor or the Project except as to claims against the Payment Bond;

(c) That the DB Contractor has no reason to believe that any Person has a valid claim against the DB Contractor or the Project which has not been communicated in writing by the DB Contractor to the Mobility Authority as of the date of the certificate; and

(d) That all guarantees, Warranties and the Payment Bond and the Performance Bond are in full force and effect.

Said release and the affidavit shall survive Final Payment.

13.5.5 All prior Draw Requests shall be subject to correction in the Final Draw Request.

13.5.6 The Mobility Authority will review the DB Contractor's proposed Final Draw Request, and changes or corrections will be forwarded to the DB Contractor for correction within 15 Business Days. The Mobility Authority shall pay any undisputed amounts, less any Losses that have accrued as of the date of the Final Payment, within 30 Days after its approval of such amounts on the application for Final Payment, but not earlier than the date of Final Acceptance. If no changes or corrections are required, the Mobility Authority will accept the Final Draw Request and make such payment within 30 Days after its acceptance thereof.

13.6 Taxes

13.6.1 The DB Contractor shall pay, prior to delinquency, any and all sales and use taxes, property taxes and other taxes, fees, charges or levies (not based on income) imposed by a Governmental Entity on the DB Contractor which are related to the Work; provided, however, that the DB Contractor shall not be in breach of this Section 13.7 for failure to make such payments prior to delinquency to the extent that (i) such failure is due to a good faith dispute by the DB Contractor as to whether the DB Contractor is subject to such taxes or the amount thereof; (ii) the DB Contractor seeks expeditiously to resolve such dispute; (iii) such taxes will not become a Lien against the Project and/or the Final ROW; (iv) failure to pay such taxes during the pendency of such dispute shall not adversely affect the Project; and (v) the DB Contractor posts such bonds or other security reasonably requested by the Mobility Authority.

13.6.2 The DB Contractor and the Mobility Authority acknowledge that Mobility Authority is exempt from paying sales tax on Expendable Materials purchases within the State with respect to the Project. If material and equipment purchases for the Work are not wholly used or expended on the Project, the DB Contractor shall be responsible for applicable sales taxes.

13.7 Value-Added Concepts

The proposals submitted by the DB Contractor to the Mobility Authority for Value-Added Concepts shall be valid for a period of 365 days from the Proposal Date; provided, however, that the DB Contractor shall not be required to implement a Value-Added Concept for the price proposed in its Proposal if the DB Contractor specified in its Proposal that such Value-Added Concept could only be implemented if accepted by Mobility Authority at execution of this DB Agreement. If the Mobility Authority does not incorporate the terms of a Value-Added Concept into the DB Agreement as a contractual obligation during finalization/execution of this DB Agreement then it may do so as a Change Order under this DB Agreement. The scope contained in the Value-Added Concept shall be unchanged within the 365 day period; any changes shall be agreed to in writing by both parties. The price contained in the Value-Added Concept shall initially be valid for acceptance by the Mobility Authority for a period of 210 days after the Proposal Date. The Mobility Authority shall have the right to extend this date for up to an additional 155 days, provided that the Value-Added Concept price will be subject to increase or decrease based on the *Engineering News Record* Construction Cost Index ("**ENR CCI**"), commencing as of the expiration of the 210-day period. The procedure for determining the increase or decrease in the Value-Added Concept price shall be the same as set forth in Section 13.2.2.1 above.

14. CHANGES IN THE WORK

This Section 14 sets forth the requirements for obtaining all Change Orders under this DB Agreement. The DB Contractor acknowledges and agrees that the DB Price constitutes full compensation for performance of all Work, subject only to those express exceptions specified in this Section 14, and that the Mobility Authority is subject to constraints which limit its ability to increase the DB Price or to extend contractual deadlines for performance. The DB Contractor unconditionally and irrevocably waives the right to any claim for a time extension or for any monetary compensation in addition to the DB Price and other compensation specified in this DB Agreement for the Work, except as expressly set forth in this Section 14. To the extent that any other provision of this DB Agreement expressly provides for a Change Order to be issued, such

provision is incorporated into and subject to this Section 14. Provisions of this Section 14, including provisions incorporated into this Section 14, permitting or requiring the revision of either Completion Deadlines or the DB Price shall be deemed to permit or require the revision of other terms and conditions of the Contract Documents if and as required to fully and equitably address the circumstances.

14.1 Change Orders

14.1.1 Definition of and Requirements Relating to Change Orders

14.1.1.1 Change Orders

The term "**Change Order**" shall mean a written amendment to the terms and conditions of the Contract Documents issued in accordance with this Section 14. The Mobility Authority may issue unilateral Change Orders as specified in Section 14.2. Change Orders may be requested by the DB Contractor only pursuant to Section 14.3. Change Orders may be issued for the following purposes (or combination thereof):

- (a) to modify the scope of the Work;
- (b) to revise the Completion Deadline or the Acceptance Deadline;
- (c) to revise the DB Price; and
- (d) to revise other terms and conditions of the Contract Documents.

Upon the Mobility Authority's approval of the matters set forth in the Change Order form, whether it is initiated by the Mobility Authority or the DB Contractor, the Mobility Authority shall execute such Change Order form.

14.1.1.2 Issuance of Directive Letter

The Mobility Authority may, at any time, issue a letter to the DB Contractor in the event of any desired change in the Work or in the event of any dispute regarding the scope of the Work to be performed by the DB Contractor (a "**Directive Letter**"). The Directive Letter will describe the Work in question and will state the basis for determining compensation, if any. The DB Contractor will proceed with the Work in a manner and pursuant to a schedule as directed in the Directive Letter, pending the execution of a formal Change Order or, if the Directive Letter states that the Work is within the original scope of the Work, the DB Contractor will proceed with the Work as directed, but shall have the right to submit the question of entitlement to a Change Order and the amount of allowable compensation and time to dispute resolution in accordance with Section 25 of this DB Agreement.

14.1.1.3 Prerequisites for Change Orders for Work Outside of Scope

As a condition precedent to the DB Contractor's entitlement to a price increase or time extension for work which the DB Contractor believes is outside of the scope of the Work, the DB Contractor shall have received either a Directive Letter from the Mobility Authority stating that it is issued pursuant to Section 14.1.1.2 or a Change Order for such item signed by the Mobility Authority. The DB Contractor shall not be entitled to additional compensation or time extension for any such work performed prior to receipt of a Directive Letter or Change Order, except to the extent that Section 14.3.2.2 preserves the DB Contractor's right to compensation for work performed following delivery of a Request for Change Order Resolution Meeting. The DB Contractor acknowledges that it will be at risk if it elects to proceed with any such work, since the Mobility Authority may later decide not to provide direction with regard to such work.

14.1.1.4 Additional Provisions Concerning Directive Letters

In addition to provision of a Proposed Change Order ("**PCO**") Notice and subsequent Change Order request pursuant to Section 14.3.2, receipt of a Directive Letter from the Mobility Authority shall be a condition precedent to the DB Contractor's right to make a Claim that a Mobility Authority-Directed Change has occurred. However, the fact that a Directive Letter was issued by the Mobility Authority shall not be considered evidence that a Mobility Authority-Directed Change has occurred. The determination as to whether a Mobility Authority-Directed Change has occurred shall be based on an analysis of the original requirements of the Contract Documents and a determination whether the Directive Letter constituted a change in those requirements. The foregoing requirements do not require that a Directive Letter be issued by the Mobility Authority in order for the DB Contractor to have the right to receive compensation for Work within the original scope of the Work (such as certain types of Utility Adjustment Work) for which additional compensation is specifically allowed under this Section 14.

14.1.2 Right of the Mobility Authority to Issue Change Orders

The Mobility Authority may, at any time and from time to time, without notice to any Surety or Guarantor, authorize and/or require changes in the Work within the general scope of the Work pursuant to a Change Order. All additions, deductions or changes to the Work as directed by Change Orders shall be executed under the conditions of the original Contract Documents.

14.2 Procedure for Issuance of Change Orders by the Mobility Authority

This Section 14.2 concerns Change Orders issued by the Mobility Authority following a Request for Change Proposal and Change Orders unilaterally issued by the Mobility Authority.

14.2.1 Request for Change Proposal

14.2.1.1 If the Mobility Authority desires to issue a Mobility Authority-Directed Change or to evaluate whether to initiate such a change, the Mobility Authority may, at its discretion, issue a Request for Change Proposal. The Mobility Authority may, at any time, ask the DB Contractor to provide two alternative Change Order forms in accordance with Section 14.3.3.

14.2.1.2 Within five Business Days after the DB Contractor's receipt of a Request for Change Proposal, the Mobility Authority and the DB Contractor shall arrange an initial consultation (at no charge to the Mobility Authority) concerning the estimated cost and time impacts. The DB Contractor shall deliver a statement of costs and time impacts, as well as any other requested data, to the Mobility Authority no later than ten (10) Business Days after the DB Contractor receives a Request for Change Proposal. The Mobility Authority, in its sole discretion, may extend this deadline. In the event that the DB Contractor does not deliver the requested statement of costs and time impacts and other requested data by the deadline, as extended, the Mobility Authority may impose a fee of \$5,000 per Day until the requested statement and related data are provided.

14.2.1.3 After the initial consultation and delivery by the DB Contractor of data and information as described in Section 14.2.1.2, the Mobility Authority shall notify the DB Contractor whether the Mobility Authority (a) wishes to issue a Change Order, (b) wishes to request the DB Contractor to prepare a Change Order form as discussed at the consultation, or (c) no longer wishes to issue a Change Order.

14.2.1.4 If so requested, the DB Contractor shall, within ten (10) Business Days after receipt of the notification described in Section 14.2.1.3 (as such deadline may be extended by the Mobility Authority), prepare and submit to the Mobility Authority a Change Order form, complying with all applicable requirements of Section 14.6.1 and incorporating and fully reflecting all requests made by the Mobility Authority. If the DB Contractor determines that it cannot meet the time allowed, the DB Contractor shall notify the Mobility Authority in writing of the DB Contractor's proposed deadline for providing the Change Order form, which deadline shall be subject to approval in writing by the Mobility Authority. In the event the DB Contractor fails to prepare and submit the required Change Order form by the deadline, as extended, the Mobility Authority may impose a fee of \$5,000 per Day until the Change Order form is provided. Development of the cost estimate and scope, including any modifications thereto requested by the Mobility Authority, shall be made at the DB Contractor's cost and expense, except that costs of design and engineering work required for preparation of plans or exhibits necessary to the Change Order form shall be included in the Change Order as reimbursable items. The Mobility Authority may, but shall not be obligated to, reimburse part or all of the DB Contractor's Change Order development costs and expenses if no Change Order is ultimately issued.

14.2.1.5 If the Parties agree that a change in the requirements relating to the Work has occurred, but disagree as to whether the change results in an increase or decrease in compensation or time or disagree as to the amount of any increase or decrease to be made to the DB Price or extension of time, the Mobility Authority may, in its sole discretion, order the DB Contractor to proceed with the performance of the Work in question notwithstanding such dispute. Such order may, at the Mobility Authority's option, be in the form of: (a) a Time and Materials Change Order as provided in Section 14.7 or (b) a Directive Letter under Section 14.1.1.2, which shall specify the basis for determining compensation.

14.2.1.6 Any delay in issuance of NTP1 by the Mobility Authority shall be deemed to constitute a Request for Change Proposal with respect to such delay entitling the DB Contractor to a Change Order in accordance with Section 13.2.

14.2.1.7 In the event the Mobility Authority shall issue a Request for Change Proposal requesting that the DB Contractor implement a Value-Added Concept proposed by the DB Contractor in its Proposal, the DB Contractor shall be required to provide the additional Work related to such Change Order so long as such Request for Change Proposal is issued by the Mobility Authority within 365 Days of the Proposal Date. Any such Request for Change Proposal to implement a Value-Added Concept that is issued by the Mobility Authority more than 210 Days after the Proposal Date shall be subject to price adjustment based on the formula contained in Section 13.2.2.1. Notwithstanding the above, the DB Contractor shall not be required to implement a Value-Added Concept for the price proposed in its Proposal if the DB Contractor specified in its Proposal that such Value-Added Concept could only be implemented if accepted by the Mobility Authority at the time of the execution of this DB Agreement.

14.2.2 Unilateral Change Orders for Mobility Authority-Directed Changes

The Mobility Authority may issue a Change Order for a Mobility Authority-Directed Change at any time, regardless of whether it has issued a Request for Change Proposal. Any such Change Order shall state that the DB Contractor shall be entitled to compensation in accordance with Section 14.7 or Section 14.6 (at the discretion of the Mobility Authority) for the additional Work required thereby and an extension of the Completion Deadline if permitted pursuant to Section 14.3.1.1.

14.3 DB Contractor-Requested Change Orders

14.3.1 Eligible Changes

14.3.1.1 The DB Contractor may request a Change Order to extend the Completion Deadline or the Acceptance Deadline only for delays directly attributable to (a) Mobility Authority-Caused Delays; (b) Force Majeure Events; (c) Hazardous Material Delays to the extent allowed pursuant to Section 14.8.3; (d) discovery within the Schematic ROW of an Unidentified Utility (subject in all cases to a requirement to show that the delay actually extended the duration of a Critical Path so as to delay Substantial Completion or Final Acceptance beyond the applicable deadline, and provided that if a Mobility Authority-Caused Delay is concurrent with another delay that is the DB Contractor's responsibility under the Contract Documents, then such delay shall be borne 100% by the DB Contractor and the DB Contractor shall not be entitled to a time extension for the concurrent Mobility Authority-Caused Delay); or (e) additional Work

directly related to reconstruction of portions of the existing US 183 facility resulting from disapproval of design exceptions for existing nonstandard cross slopes and longitudinal grades.

14.3.1.2 The DB Contractor may request a Change Order to increase the DB Price, subject to strict compliance with the requirements of this Section 14 and Section 13, only for increased costs of the Work as follows:

(a) Additional costs directly attributable to additional Work resulting from Mobility Authority-Directed Changes for which the Mobility Authority has not submitted a Change Order or a Request for Change Proposal;

(b) Additional costs directly attributable to Mobility Authority-Caused Delays (except for the Mobility Authority's failure to issue NTP2 within 90 Days of the date of issuance of NTP1 pursuant to Section 13.2.2.3 of this DB Agreement);

(c) Additional costs directly attributable to Force Majeure Events, excluding costs which are compensable by the builder's risk or any other insurance required to be provided hereunder, and subject to Section 14.10;

(d) Additional costs of Hazardous Materials Management, to the extent specified in Section 14.8, but subject to Section 7.5;

(e) Additional costs relating to Differing Site Conditions, to the extent specified in Section 14.9;

(f) Additional costs with respect to Utility Adjustment Work, to the extent specified in Section 14.12;

(g) Subject to prior approval by the Mobility Authority, additional costs related to redesign where discovery of Hazardous Materials requires a change to the DB Contractor's previously prepared design plans;

(h) Additional costs related to repairs resulting from third party actions to the extent specified in Section 11.2; and

(i) Additional costs directly related to reconstruction of portions of the existing US183 facility resulting from disapproval of design exceptions for existing nonstandard cross slopes and longitudinal grades.

14.3.2 Notification Requirements as Conditions Precedent

In all circumstances except those involving a Request for Change Proposal or escalation pursuant to Section 13.2.2, the DB Contractor's entitlement to request a Change Order shall be contingent on its compliance with the requirements set forth in this Section 14.3.2.

14.3.2.1 Delivery of Requests for Change Order Resolution Meeting and PCO Notices

The DB Contractor acknowledges the importance of providing prompt notification to the Mobility Authority upon occurrence of any event or thing entitling the DB Contractor to a Change Order under Section 14.3.1. Among other things, such notification serves the purpose of allowing the Mobility Authority to take action to mitigate adverse impacts. Such notification must be delivered as promptly as possible after the occurrence of such event or situation, through either (a) a PCO Notice as described in Section 14.3.2.3 or (b) if permitted by Section 14.3.2.2, a Request for Change Order Resolution Meeting followed by a PCO Notice if appropriate. The DB Contractor understands that it shall be forever barred from recovering against the Mobility Authority unless it gives such written notice(s) and, thereafter, files a request for Change Order with the Mobility Authority and complies with the remaining requirements of this Section 14.3.2.

14.3.2.2 Requests for Change Order Resolution Meeting

The term "**Request for Change Order Resolution Meeting**" shall mean a notice delivered by the DB Contractor requesting that the Mobility Authority schedule a meeting with the DB Contractor to discuss an event or situation that has occurred within the scope of Section 14.3.1.2. The Request for Change Order Resolution Meeting shall reference this Section 14.3.2.2 and shall describe the event or situation as well as action which the DB Contractor would like to take with respect thereto. The parties shall promptly meet and confer for the purpose of determining what action should be taken and also to determine whether the parties are in agreement as to entitlement to a Change Order. Either party may at any time terminate change order resolution discussions by delivery of written notice to the other, and change order resolution discussions shall automatically terminate 60 Days after delivery of the Request for Change Order Resolution Meeting unless both parties agree in writing to an extension. Within two (2) Business Days after termination of change order resolution discussions, if the Mobility Authority has not issued either a Directive Letter or Change Order, the DB Contractor must submit a PCO Notice in order to preserve its right to pursue a Change Order. The foregoing process is not available for events or situations involving a delay to the Critical Path. With regard to any such events or situations, the DB Contractor must submit a PCO Notice as provided in Section 14.3.2.3.

14.3.2.3 PCO Notices

The term "**PCO Notice**" shall mean a proposed change order notice delivered by the DB Contractor, meeting the requirements set forth below, stating that an event or situation has occurred within the scope of Section 14.3.1.1 or Section 14.3.1.2 and stating which section thereof is applicable. The first notice shall be labeled "PCO Notice No. 1" and subsequent notices shall be numbered sequentially.

14.3.2.3.1 The PCO Notice shall: (a) state in detail the facts underlying the claim for a Change Order, the reasons why the DB Contractor believes additional compensation or time will or may be due and the date of occurrence, (b) state the name, title, and activity of each Mobility Authority representative knowledgeable of the facts underlying the claim for a Change Order, (c) identify, and include copies of, any documents and the substance of any oral communication involved in the claimed change, (d) state in detail the basis for any claim of the necessity to accelerate schedule performance, (e) state in detail the basis for any claim that

work is not required by the Contract Documents, (f) identify particular elements of performance for which additional compensation may be sought under this *Section 14*, (g) identify any potential Critical Path impacts, (h) provide an estimate of the time within which a response from the Mobility Authority to the PCO Notice is required to minimize cost, delay, or disruption of performance; and (i) to the degree possible, address price element(s) that have been or may be affected by the claimed change and provide a budget, such price estimate to be based on one of the following methods: (1) TxDOT Prices or (2) RS Means Heavy Construction Costs Data Book-Latest Edition.

14.3.2.3.2 If the claim relates to a decision which this DB Agreement leaves to the sole discretion of a Person or as to which this DB Agreement provides that such Person's decision is final, the PCO Notice shall set out in detail all facts supporting the DB Contractor's objection to the decision, including all facts supporting any contention that the decision was capricious or arbitrary or is not supported by the facts.

14.3.2.3.3 Within fifteen (15) Business Days after receipt of a complete PCO Notice that meets the requirements of this *Section 14.3.2.3*, the Mobility Authority will respond in writing to the DB Contractor to: (a) confirm that a change has occurred; (b) deny that a change has occurred or (c) advise the DB Contractor that the necessary information has not been submitted to decide which of the above alternatives applies, and indicate the needed information and date by which it is to be received for further review. Failure of the Mobility Authority to respond shall not affect the DB Contractor's obligation to provide a request for Change Order within the time periods specified in this *Section 14*. Any adjustments made to this DB Agreement shall not include increased costs or time extensions for delay resulting from the DB Contractor's failure to provide a complete PCO Notice or requested additional information under this *Section 14.3.2.3*.

14.3.2.4 **Waiver**

14.3.2.4.1 If any PCO Notice is delivered later than (10) ten Days after the DB Contractor first discovered (or should have discovered in the exercise of reasonable prudence) the occurrence which is described therein, or if it is delivered later than two Business Days following termination of change order resolution discussions, the DB Contractor shall be deemed to have waived (a) the right to collect any costs incurred prior to the date of delivery of the Request for Change Order Resolution Meeting (if applicable) or PCO Notice (if no Request for Change Order Resolution Meeting was submitted or if the PCO Notice was not timely submitted following termination of change order resolution discussions) and (b) the right to seek an extension of any deadline hereunder with respect to any delay in any Critical Path which accrued prior to the date of delivery of the PCO Notice. Furthermore, if the PCO Notice concerns any condition or material described in *Section 7.5.1* or *Section 14.10*, the DB Contractor shall be deemed to have waived the right to collect any costs incurred in connection therewith if the Mobility Authority is not afforded the opportunity to inspect such material or condition before it is disturbed, unless the DB Contractor can demonstrate to Mobility Authority's reasonable satisfaction that its actions with respect to such condition or material were necessary to prevent imminent danger to persons, property or the environment.

14.3.2.4.2 In addition to the limitations described in *Section 14.3.2.4.1*, the DB Contractor's failure to provide a PCO Notice within 60 Days after the

DB Contractor first discovered (or should have discovered in the exercise of reasonable prudence) the occurrence of a given event or situation shall preclude the DB Contractor from any relief, unless the DB Contractor can show, based on clear and convincing evidence, that the Mobility Authority was not prejudiced by the lack of the PCO Notice. For situations involving Requests for Change Order Resolution Meeting, the 60-Day period shall be extended until two Business Days following termination of the change order resolution period. In other words, if the requirements above are satisfied, the DB Contractor shall retain the right to receive a Change Order, but shall be deemed to have waived the right to collect any and all costs incurred prior to the date of delivery of the PCO Notice or Request for Change Order Resolution Meeting, as applicable, and shall be deemed to have waived the right to seek a time extension with respect to any delay in any Critical Path which accrued prior to the date of delivery of the PCO Notice. The following factors (among others) shall be considered in determining whether the Mobility Authority has been prejudiced by the DB Contractor's failure to provide notice in a timely fashion: (a) the effect of the delay on alternatives available to the Mobility Authority; that is, a comparison of alternatives which are available at the time notice was actually given and alternatives which would have been available had notice been given within the required time period; and (b) the impact of the delay on the Mobility Authority's ability to obtain and review objective information contemporaneously with the event.

14.3.2.5 **Delivery of Requests for Change Orders**

The DB Contractor shall deliver all requests for Change Orders under this *Section 14.3* to the Mobility Authority within thirty (30) Days after delivery of the PCO Notice, or such longer period of time as may be reasonably necessary, provided that the DB Contractor shall have notified the Mobility Authority in writing prior to expiration of said 30-Day period how much additional time is required and obtained the Mobility Authority's approval of the same. The Mobility Authority may require design and construction costs to be covered by separate Change Order requests. If the DB Contractor fails to deliver a complete request for Change Order or incomplete request for Change Order meeting all the requirements of *Section 14.3.2.6* within the appropriate time period, the DB Contractor shall be required to provide a new PCO Notice before it may submit a request for Change Order and the DB Contractor shall not be entitled to increased costs or time extensions resulting from the DB Contractor's failure to deliver a complete request for Change Order.

14.3.2.6 **Incomplete Change Orders**

Each request for Change Order delivered by the DB Contractor shall meet all requirements set forth in *Section 14.4*; provided that if any such requirements cannot be met due to the nature of the occurrence, the DB Contractor shall provide an incomplete Change Order which shall:

- (a) Comply with all requirements capable of being met;
- (b) Include a list of requirements which are not fulfilled together with an explanation reasonably satisfactory to the Mobility Authority stating why such requirements cannot be met;
- (c) Provide such information regarding projected impact on the Critical Path as is requested by the Mobility Authority; and

(d) In all events include sufficient detail to ascertain the basis for the proposed Change Order and for any price increase associated therewith, to the extent such amount is then ascertainable.

The DB Contractor shall furnish, when requested by the Mobility Authority, such further information and details as may be required to determine the facts or contentions involved. The DB Contractor agrees that it shall give the Mobility Authority access to any and all of the DB Contractor's books, records and other materials relating to the Work, and shall cause its Subcontractors to do the same, so that the Mobility Authority can investigate the basis for such proposed Change Order. The DB Contractor shall provide the Mobility Authority with a monthly update to all outstanding incomplete requests for Change Order, describing the status of all previously unfulfilled requirements and stating any changes in projections previously delivered to the Mobility Authority, time expenditures to date and time anticipated for completion of the activities for which the time extension is requested. The Mobility Authority may reject the DB Contractor's request at any point in the process. Once a complete request for Change Order is provided, the Mobility Authority's failure to respond thereto within fifteen (15) Business Days of receipt of the request shall be deemed a rejection of such request. Although the Mobility Authority intends to review incomplete Change Orders for the purposes described in this *Section 14.3.2.6*, the Mobility Authority shall have no obligation to review the back-up associated with any request for Change Order until a complete Change Order is provided.

14.3.2.7 Subcontractor Claims

Prior to submission by the DB Contractor of any request for a Change Order which is based in whole or in part on any facts alleged in a submittal by any Subcontractor to the DB Contractor, the DB Contractor shall review all such Subcontractor claims and determine in good faith whether the claims are justified as to both entitlement and amount, and the DB Contractor's request for a Change Order shall include only those items which the DB Contractor has determined are so justified and which otherwise meet all requirements hereunder for the DB Contractor-requested Change Orders. The DB Contractor shall include with its request for Change Order a summary of its analysis of all Subcontractor claims components. Notwithstanding the foregoing, where necessary to meet the notice requirements of this DB Agreement or avoid potential prejudice to the Mobility Authority, the DB Contractor may give a PCO Notice prior to making or completing its good faith determination.

14.3.3 Submission of Request for Change Order

The DB Contractor shall initiate each request for a Change Order, after satisfaction of all conditions precedent set forth above, by submitting a Change Order form and supporting documentation to the Mobility Authority for its review and approval. If the DB Contractor submits a request for Change Order requesting a time extension, as permitted by *Section 14.3*, then the DB Contractor shall also provide an alternative Change Order form including a Recovery Schedule in accordance with *Section 5.5.3*.

14.3.4 Performance of Disputed Work

If the Mobility Authority refuses to issue a Change Order based on the DB Contractor's request, the DB Contractor shall nevertheless promptly perform all work as specified in an

appropriate Directive Letter, with the right to submit the issue of entitlement to a Change Order to dispute resolution in accordance with Section 25 of this DB Agreement. The DB Contractor shall maintain and deliver to the Mobility Authority, upon request, contemporaneous records, meeting the requirements of Section 14.7, for all work performed which the DB Contractor believes constitutes extra work (including non-construction work), until all Disputes regarding entitlement or cost of such work are resolved.

14.4 Form and Contents of Change Orders

14.4.1 Form of Change Order

Each Change Order shall (a) be prepared in form acceptable to the Mobility Authority, (b) otherwise meet all applicable requirements of this Section 14 and (c) be substantially in the form of Exhibit M. Each Change Order shall specify whether it is subject to contingencies and shall identify the applicable section of this Section 14 under which the Change Order is issued.

14.4.2 Contents of Change Order

The DB Contractor shall prepare a scope of work, cost estimate, delay analysis and other information as required by this Section 14.4.2 for each Change Order, other than Change Orders issued unilaterally by the Mobility Authority.

14.4.2.1 The scope of work shall describe in detail satisfactory to the Mobility Authority all activities associated with the Change Order, including a description of additions, deletions and modifications to the existing requirements of the Contract Documents and, if requested by the Mobility Authority, a description of steps taken by the DB Contractor to mitigate the cost of the work and delay impact and a description of alternative courses of action considered by the DB Contractor, together with an explanation as to why the alternatives were not selected.

14.4.2.2 The cost estimate shall set out the estimated costs in such a way that a fair evaluation can be made. It shall include a breakdown (quantity and unit rate) for labor, materials, equipment, overhead (which includes all indirect costs) and profit, unless the Mobility Authority agrees otherwise. The estimate shall include costs allowable under Section 14.5.2, if any. If the work is to be performed by Subcontractors and if the work is sufficiently defined to obtain Subcontractor quotes, the DB Contractor shall obtain quotes (with breakdowns showing cost of labor, materials, equipment, overhead and profit) on the Subcontractor's stationery and shall include such quotes as back-up for the DB Contractor's estimate, provided that such Subcontractor quotes must be in accordance with Section 14.7.4 and must be commercially reasonable and cannot include labor rates, overhead or profit that is materially higher than the labor rates, overhead and profit the Subcontractor is currently charging for any non-Change Order Work. No mark-up shall be allowed in excess of the amounts allowed under Sections 14.5 and 14.7. The DB Contractor shall identify all conditions with respect to prices or other aspects of the cost estimate, such as pricing contingent on firm orders being made by a certain date or the occurrence or non-occurrence of an event.

14.4.2.3 If the DB Contractor claims that such event, situation or change affects a Critical Path, it shall provide an impacted delay analysis indicating all activities represented or affected by the event, situation or change, with activity numbers, durations,

predecessor and successor activities, resources and costs and a narrative report, in form satisfactory to the Mobility Authority, which compares the proposed new Project Schedule to the then-current approved Project Schedule.

14.4.2.4 The DB Contractor shall provide such other supporting documentation as may be required by the Mobility Authority.

14.4.3 Justification

The DB Contractor shall provide a narrative justification to be included in each Change Order other than Change Orders issued unilaterally by the Mobility Authority, describing the circumstances underlying the proposed Change Order, identifying the specific provision(s) of Section 14 which permit a Change Order to be issued and describing the data and documents (including any required data and reports) which establish the necessity and amount of compensation and/or time extension sought by such proposed Change Order.

14.4.4 DB Contractor Representation

Each Change Order form shall contain a written representation by the DB Contractor in form acceptable to the Mobility Authority that the amount of time and/or compensation requested includes all known and anticipated direct, indirect, and consequential impacts or amounts which may be incurred as a result of the event, occurrence or matter giving rise to such proposed Change Order, and that the DB Contractor has no reason to believe and does not believe that the factual basis for the Change Order is falsely represented.

14.5 Limitations on Change Orders

14.5.1 Exclusion from Price Increase

Any increase in the DB Price pursuant to a Change Order shall exclude: (a) costs caused by the breach, default, fault, wrongful act, wrongful omission, negligence, recklessness, gross negligence or willful misconduct of any member of the DB Contractor Group; (b) costs to the extent they are unnecessary or could reasonably be avoided by the DB Contractor or the other members of the DB Contractor Group, including by resequencing, reallocating or redeploying its forces to other portions of the Work or to other activities unrelated to the Work; and (c) costs for any rejected Work which failed to meet the requirements of the Contract Documents, applicable Law or the Governmental Approvals, or for any remedial work. Costs incurred for the purpose of mitigating damages as described in (b) above, and not otherwise disallowed hereunder, would be reimbursable.

14.5.2 Delay Damages and Acceleration Costs

14.5.2.1 Acceleration Costs or other delay or disruption damages, including extended overhead, shall be compensable hereunder only in the case of Mobility Authority-Caused Delays or Force Majeure Events.

14.5.2.2 Before the DB Contractor may obtain any increase in the DB Price to compensate for additional or extended overhead, Acceleration Costs or other damages directly attributable to Mobility Authority-Caused Delays, the DB Contractor shall be required to demonstrate to the Mobility Authority's reasonable satisfaction that:

(a) The Project Schedule which defines the affected Critical Path was, in its inception, a reasonable method for completion of the Work;

(b) The change, occurrence, event or situation which is the subject of the request for Change Order has caused or will result in an identifiable and measurable disruption of the Work which has or will impact a Critical Path item; and

(c) The delay or damage was not caused by, related to, arising from or aggravated by any delay, breach, default, fault, act, omission, negligence, recklessness, gross negligence or willful misconduct of any member of the DB Contractor Group and could not reasonably have been avoided by the DB Contractor or the other members of the DB Contractor Group, including by resequencing, reallocating or redeploying its forces to other portions of the Work.

In addition, as a condition to any Acceleration Costs or delay or disruption damages, the DB Contractor shall provide detailed documentation of such costs satisfactory to the Mobility Authority.

14.5.2.3 Acceleration Costs are permitted only with respect to Change Orders issued as an alternative to allowing an extension of a Completion Deadline as contemplated by Sections 14.3.1.1 and 14.3.3. If the Mobility Authority elects to have the DB Contractor accelerate the Project, no additional or extended overhead cost will be allowed.

14.5.2.4 Where delay damages are allowed pursuant to this Section 14.5.2, any extended overhead payable to the DB Contractor shall be limited to (a) Project Office rent and utility costs, and (b) salaries and benefits for administrative staff, including Category A Personnel, required to maintain the Project Office for the extended period associated with the delay.

14.5.3 Limitation on Time Extensions

Any extension of time shall exclude any delay to the extent that it (a) was due to the delay, breach, default, fault, act, omission, negligence, recklessness, gross negligence, or willful misconduct of any member of the DB Contractor Group, or (b) could reasonably have been avoided by the DB Contractor or the other members of the DB Contractor Group, including by resequencing, reallocating or redeploying its forces to other portions of the Work. Costs incurred for the purpose of mitigating delays as described in (b) above, and not otherwise disallowed hereunder, would be reimbursable.

14.5.4 Work Performed Without Direction

To the extent that the DB Contractor undertakes any work or makes any payment that is not part of the Work, unless the DB Contractor (a) has received from the Mobility Authority a Directive Letter or Change Order directing the DB Contractor to do such work or make such payment or (b) has preserved its rights by delivery of a Request for Change Order Resolution Meeting under Section 14.3.2.2, the DB Contractor shall be deemed to have performed such work or made such payment voluntarily and shall not be entitled to a Change Order in connection therewith.

14.6 Pricing of Change Orders

The Mobility Authority and the DB Contractor (on its own behalf and on behalf of its Subcontractors) shall endeavor to negotiate, in good faith, a reasonable cost for each Change Order, provided that unilateral Change Orders are not subject to negotiations. The price of a Change Order shall be negotiated in accordance with this Section 14.6 or shall be based on time and materials records pursuant to Section 14.7. The price of a Change Order shall be based upon one of the following methods: (1) TxDOT Prices, (2) RSMeans Heavy Construction Costs Book-Latest Edition, or (3) as may be agreed to by the parties, established production rates on the Project for like or similar activities.

14.6.1 Contents

A negotiated Change Order shall specify scheduling requirements, time extensions and all costs of any nature arising out of the Work covered by the Change Order. Notwithstanding the foregoing, the parties may mutually agree to use a multiple-step process involving issuance of a Change Order which includes an estimated construction cost and which provides for a revised Change Order to be issued after a certain design level has been reached, thus allowing a refinement and further definition of the estimated construction cost. The Mobility Authority shall have the right to require that any or all of the information submitted by the DB Contractor in the Escrowed Proposal Documents (EPDs) be used in evaluating the cost proposal.

14.6.2 Added Work

When the Change Order adds work to the DB Contractor's scope, the increase in the DB Price shall be based upon one of the following methods: (1) TxDOT Prices, (2) RS Means Heavy Construction Cost Data Book-Latest Edition, (3) as may be agreed to by the parties, established production rates on the Project for like or similar activities, or (4) shall be based on actual costs in accordance with Section 14.7, at the sole discretion of the Mobility Authority. Estimated costs shall not be based on costs contained in the DB Contractor's Proposal. For all Change Orders, except those pursuant to Section 14.2.2, mark-ups for profit and overhead shall be consistent with Section 14.7, and risk associated with the work described in the Change Order shall be addressed through the assumptions contained therein regarding the scope of such work.

14.6.3 Deleted Work

When the Change Order deletes work from the DB Contractor's scope (including deletion of any work described in the Scope of Work that is found to be unnecessary by the Mobility Authority, in its sole discretion), the amount of the reduction in the DB Price shall be based upon

one of the following methods: (1) TxDOT Prices or (2) RSMeans Heavy Construction Cost Data Book-Latest Edition. Estimated costs shall not be based on costs contained in the DB Contractor's Proposal. When a deduction is involved, documented cancellation and restocking charges may be included in costs and subtracted from the price deduction.

14.6.4 Work Both Added and Deleted

When the Change Order includes both added and deleted Work that is logically related, the DB Contractor shall prepare a statement of the cost of labor, material and equipment for both added and deleted work using the methodology set forth in Sections 14.6.2 and 14.6.3.

(a) If the change results in a net increase in cost, the change shall be treated as work added and the provisions of Section 14.6.2 shall be used to determine mark-ups for overhead and profit. Mark-ups for overhead and profit will be allowed only for the net increase in cost in order to establish the amount to be added to the DB Price.

(b) If the change results in a net decrease in cost, the change shall be treated as work deleted and the provisions of Section 14.6.3 shall be used on the net decrease in cost in order to establish the price to be deducted from the DB Price.

(c) If the change results in a net change of zero, there will be no change in the DB Price.

14.6.5 All-Inclusive Change Orders

All Change Orders submitted by the DB Contractor shall be all-inclusive, comprehensive and complete and shall not include any conditions with respect to pricing or schedule.

14.7 Time and Materials Change Orders and Cost Data

The Mobility Authority may, at its discretion, issue a Time and Materials Change Order at any time. The Time and Materials Change Order shall instruct the DB Contractor to perform work as specified therein, indicating expressly the intention to allow compensation therefor, and setting forth the kind, character, and limits of the work in question insofar as they can be ascertained, the terms under which changes to the DB Price will be determined and the estimated total change in DB Price anticipated thereunder. Upon final determination of the allowable costs, the Mobility Authority shall issue a modified Change Order setting forth the final adjustment to the DB Price. The following costs and mark-ups (and no others) shall be used for calculating the change in the DB Price:

14.7.1 Labor Costs

The cost of labor for workers used in the actual and direct performance of the Change Order work, whether provided by the DB Contractor or a Subcontractor, will equal the sum of the following:

(a) For construction-related labor, (1) the actual Direct Cost for direct labor; plus (2) for health, welfare and pension benefits and Social Security deductions, 55% of the actual

direct labor cost; plus (3) 25% of the total of the amounts set forth in clauses (1) and (2) for profit and overhead.

(b) For non-construction-related work (professional services), (1) the actual wages (i.e. the base wage paid to the employee exclusive of any fringe benefits); plus (2) a labor surcharge in the amount of 145%, which shall constitute full compensation for all profit, overhead and all state and federal payroll, unemployment and other taxes, insurance, fringe benefits and all other payments made to, or on behalf of, the workers, in excess of actual wages.

(c) No additional payment will be made for Category A Key Personnel assigned to the Project or for Category B Personnel assigned to the Project on a full-time basis unless a time extension is granted by the Mobility Authority.

14.7.2 Material Costs

Material costs for Change Order work shall be the Direct Cost of all materials to be used in the performance of construction work including normal wastage allowance as per industry standards, less salvage value, plus 15% for profit and overhead. The material prices shall be supported by valid quotes and invoices from the suppliers.

14.7.3 Equipment

14.7.3.1 Costs for DB Contractor-owned machinery, trucks, power tools or other similar equipment that are required for Change Order Work will be allowed based on the following methodology:

(a) The Direct Cost of fuel, lubricants, repairs, parts, and depreciation will be considered without any additional compensation percentage for overhead and profit being added; and

(b) The equipment rental rates shall be those tabulated in the most recent version of the Rental Rate Blue Book (published by Equipment Watch; 1735 Technology Drive, Suite 410, San Jose, California 95110). The rental rates to be used shall be the published monthly rate divided by 150 to yield an hourly rate, which hourly rate shall be further adjusted by multiplying by the Rental Rate Blue Book adjustment rate for the year the equipment was manufactured and by a factor of 0.85 and adding to that product the Rental Rate Blue Book estimated hourly operating cost rate.

The DB Contractor shall be considered to own such items if an ownership interest therein is held by (w) the DB Contractor, (x) any equity participant in the DB Contractor, (y) any Subcontractor performing Construction Work, or (z) any Affiliate of the DB Contractor, any equity participant in the DB Contractor or any such Subcontractor. If the publication of the *Rental Rate Blue Book* should be discontinued for any reason, the Mobility Authority may select a different publication from which to make the described calculations.

14.7.3.2 Costs for machinery, trucks, power tools or other similar equipment that are required for Change Order Work rented from any commercial enterprises routinely offering equipment and tools for rent or lease to the public will be allowed in an amount equal to

the direct rental rate for the equipment without any additional mark-up or increase for overhead and profit.

14.7.3.3 The time to be paid for use of equipment on the Site shall be the time the equipment is in operation on the Change Order Work being performed. The time shall include the reasonable time required to move the equipment to the location of the Change Order Work and return it to the original location or to another location requiring no more time than that required to return it to its original location. Moving time will not be paid for if the equipment is also used at the Site other than for Change Order Work. Loading and transporting costs will be allowed, in lieu of moving time, when the equipment is moved by means other than its own power. No payment for loading and transporting will be made if the equipment is also used at the Site other than for Change Order Work. Time will be computed in half and full hours. In computing the time for use of equipment, less than 30 minutes shall be considered one-half hour.

14.7.4 Subcontracted Work

To the extent that any Change Order is intended to compensate the DB Contractor for the cost of work performed by Subcontractors, the Change Order shall provide for compensation equal to (1) the actual Direct Cost to the DB Contractor of such work (which shall be charged by the Subcontractor on a time and materials basis in accordance with this Section 14.7, unless otherwise approved in writing by the Mobility Authority), plus (2) 5% of such cost. Notwithstanding the above, no 5% mark-up shall be applied to Subcontracts with Suppliers or Affiliates of the DB Contractor.

14.7.5 Work Performed by Utility Owners

To the extent that any Change Order is intended to compensate the DB Contractor for the cost of work performed by Utility Owners entitled to receive reimbursement for their costs from the DB Contractor, the Change Order shall provide for compensation to the DB Contractor equal to (1) the actual and reasonable amount paid by the DB Contractor to the Utility Owner for such work (but not greater than the amount allowed pursuant to the applicable Utility Adjustment Agreements), plus (2) 5% of such allowed actual amount. Back-up documentation supporting each cost item for this category shall be provided by the DB Contractor and approved by the Mobility Authority in writing prior to any payment authorization being granted.

14.7.6 Other Direct Costs

For any justified change-related Direct Cost not covered by the categories of costs contained in Sections 14.7.1 through 14.7.5, the DB Contractor shall accept as full payment therefor an amount equal to the actual cost to the DB Contractor for such direct cost item. Without additional mark-up, back-up documentation supporting each cost item for this category shall be provided by the DB Contractor and approved by the Mobility Authority in writing prior to any payment authorization being granted.

14.7.7 Items Included in Mark-Ups

The mark-ups specified herein constitute full and complete compensation for all overhead, tools or equipment having an individual replacement value of \$1,000 or less, consumables (items which are consumed in the performance of the Work which are not a part of the finished product)

and other indirect costs of the added or changed Work, as well as for profit thereon, including any and all costs and expenses incurred due to any delay in connection with the added or changed Work. The DB Contractor's mark-up percentages shall be considered to include, among other costs, bond premiums, incidental job burdens, bonuses not otherwise covered, field, jobsite and general home office expenses of all types (including timekeepers, bookkeepers and other general office help), supervisory expenses of all types (excluding only direct supervision of force account work) and all other overhead, general condition and indirect costs and expenses. With respect to non-construction related labor costs, overhead is included as part of the labor surcharge calculated in accordance with Section 14.7.1(b), and includes accessories such as computer-assisted drafting and design (CADD) systems, computers, facsimile transmission machines, scanners, paper, etc.

14.7.8 Change Order Data

The DB Contractor shall contemporaneously collect, record in writing, segregate and preserve (a) all data necessary to determine the costs described in this Section 14.7 with respect to all Work which is the subject of a Change Order or a requested Change Order (excluding negotiated Change Orders previously executed and delivered), specifically including costs associated with design work as well as the DB Contractor's costs for Utility Adjustment Work, and (b) all data necessary to show the actual impact (if any) on the Critical Path, the Project Schedule, and performance deadlines with respect to all Work which is the subject of a Change Order or a proposed Change Order. Such data shall be provided to the Mobility Authority and any authorized representative of the Mobility Authority reviewing any Claim or Dispute regarding compensation for such Work. The DB Contractor hereby waives the right to obtain compensation for any work for which cost data is required to be provided hereunder, if the DB Contractor fails to maintain and timely provide to the Mobility Authority cost data meeting the requirements of this DB Agreement.

14.7.8.1 The DB Contractor shall maintain its records in such a manner as to provide a clear distinction between (a) the direct cost of Work for which it is entitled (or for which it believes it is entitled) to an increase in the DB Price and (b) the costs of other operations. The DB Contractor shall furnish daily, on forms approved by the Mobility Authority, reports of all costs described in (a) above. The reports shall itemize all costs for labor, materials, and equipment rental and give total of costs through the date of the report. For workers, the reports shall include hours worked, rates of pay, names and classifications. For equipment, the reports shall include size, type, identification number, rental rate and actual working hours of operation. All such records and reports shall be made immediately available to the Mobility Authority upon its request. The cost of furnishing such reports are deemed to be included in the DB Contractor's overhead and fee percentages.

14.7.8.2 All reports shall be signed by the DB Contractor. The Mobility Authority will compare its records with the DB Contractor's reports, make the necessary adjustments and compile the costs of Work completed under a Time and Materials Change Order. When such reports are agreed upon and signed by both Parties, they will become the basis of payment.

14.8 Hazardous Materials Management

14.8.1 Basis for Compensation

If compensation is payable to the DB Contractor pursuant to Section 7.5 with respect to Hazardous Materials Management, the amount of the Change Order shall either be a negotiated amount acceptable to the Parties, or an amount equal to 100% of the Reimbursable Hazardous Materials Costs for the work in question, subject to the limitations set forth in this Section 14.8, including the cost sharing provisions set forth in Section 14.8.

14.8.2 Determination of Reimbursable Amount

Except as otherwise provided and subject to the limitations in this Section 14.8, the Mobility Authority shall compensate the DB Contractor for (i) 100% of the DB Contractor's reasonable, out-of-pocket costs and expenses directly attributable to the handling, transport, removal and disposal of Unknown Hazardous Materials encountered by the DB Contractor that exceed \$100,000 in the aggregate, and (ii) 100% of such total chargeable Hazardous Materials Management costs for Hazardous Materials encountered on Additional Properties acquired as a result of a Mobility Authority-Directed Change, and (iii) 100% of the DB Contractor's reasonable, out-of-pocket costs and expenses directly attributable to the handling, transport, removal and disposal of Hazardous Materials falling within the definition of Force Majeure Event. The DB Contractor shall be responsible for all other costs related to Unknown Hazardous Materials.

The DB Contractor shall take all reasonable steps to minimize any such costs. Compensation shall be allowed only to the extent that the DB Contractor demonstrates to the Mobility Authority's reasonable satisfaction that: (a) the Hazardous Materials Management could not have been avoided by reasonable design modifications or construction techniques and (b) the DB Contractor's plan for the Hazardous Materials Management represents the approach which is most beneficial to the Project and the public. The DB Contractor shall provide the Mobility Authority with such information, analyses and certificates as may be requested by the Mobility Authority in order to enable a determination regarding eligibility for payment.

14.8.3 Time Extensions

If the DB Contractor encounters Hazardous Materials for which the DB Contractor is entitled to compensation, and Hazardous Materials Management of such Hazardous Materials results in delays to the Critical Path ("**Hazardous Materials Delay**") of more than 20 Days per location or more than 90 Days for all locations, then the Mobility Authority shall bear 100% of the risk of such Hazardous Materials Delay for the number of days of delay in excess of 20 Days per location or 90 Days for all locations. If a Hazardous Materials Delay is concurrent with another delay which is the DB Contractor's responsibility hereunder, then such Hazardous Materials Delay shall be borne 100% by the DB Contractor. The foregoing shall not preclude the DB Contractor from obtaining a time extension with respect to any Hazardous Material which qualifies as a Force Majeure Event.

14.8.4 Mobility Authority Right to Inspect

Unless the Environmental Team (ET) determines that immediate or emergency response action is necessary, the DB Contractor shall be deemed to have waived the right to collect from the Mobility Authority any and all costs incurred in connection with any Hazardous Materials Management if the Mobility Authority is not afforded the opportunity to inspect sites containing Hazardous Materials before any action is taken which would inhibit the Mobility Authority's ability to ascertain, based on a site inspection, the nature and extent of the Hazardous Materials.

14.8.5 Insurance Proceeds

If the cost of any Hazardous Materials Management is covered by the insurance described in Section 10, the DB Contractor shall be entitled to reimbursement of Reimbursable Hazardous Materials Costs from proceeds of insurance and self-insurance, up to the limits of the applicable policy, plus any deductibles payable under the applicable policy. To the extent that such proceeds are available, the DB Contractor shall not be entitled to payment hereunder on any other basis for such Hazardous Materials Management. If insurance proceeds are insufficient to reimburse the DB Contractor for the cost of Hazardous Materials Management, the Mobility Authority shall be responsible for any excess amount owed to the DB Contractor pursuant to the provisions of Section 7.5 and this Section 14.8.

14.8.6 Reimbursement from Third Parties

To the extent that the DB Contractor incurs Hazardous Materials Management costs in connection with remediation of Hazardous Materials which are not eligible for a Change Order hereunder but which are eligible for reimbursement from a third party outside of the DB Contractor Group, the Mobility Authority agrees to assign to the DB Contractor any causes of action held by the Mobility Authority against such third party for reimbursement of costs, subject to the Mobility Authority's prior written approval of any such action in each instance, provided that prior approval by the Mobility Authority shall not be required for costs incurred in connection with immediate or emergency response actions performed at the direction of the ET. The DB Contractor shall be responsible for identifying any potentially responsible parties. Unless the Mobility Authority otherwise informs the DB Contractor in writing, all costs associated with any action to recover Hazardous Materials Management costs from third parties will be borne by the DB Contractor. If the DB Contractor wishes to obtain such an assignment from the Mobility Authority, it shall deliver a notice requesting the same, and shall provide the Mobility Authority with a form of assignment acceptable to the Mobility Authority.

14.9 Differing Site Conditions

14.9.1 Subject to the restrictions and limitations set forth in this Section 14, the DB Contractor shall be entitled to a Change Order for certain additional costs which are directly attributable to any Differing Site Conditions to the extent permitted in this Section 14.9. No time extension shall be available with respect to Differing Site Conditions, and no delay damages shall be recovered. To the extent that additional costs are incurred in connection with the Project due to changes in the DB Contractor's obligations relating to the Work resulting from the existence of Differing Site Conditions and which are not reimbursed by insurance proceeds, the Mobility Authority and the DB Contractor shall share the risk as follows:

14.9.1.1 The DB Contractor shall be fully responsible for, and thus shall not receive a Change Order with respect to, up to \$100,000 per discovery of a Differing Site Condition and up to \$500,000 in aggregate additional costs incurred directly attributable to changes in the DB Contractor's obligations relating to the Work resulting from the existence of Differing Site Conditions.

14.9.1.2 The Mobility Authority shall be fully responsible for any additional costs incurred in excess of \$100,000 per discovery and \$500,000 in the aggregate directly attributable to changes in the DB Contractor's obligations relating to the Work resulting from the existence of Differing Site Conditions, and a Change Order shall be issued to compensate the DB Contractor for such additional costs.

14.9.2 During progress of the Work, if Differing Site Conditions are encountered, the DB Contractor shall immediately notify the Mobility Authority thereof telephonically or in person, to be followed immediately by written notification. The DB Contractor shall be responsible for determining the appropriate action to be undertaken, subject to concurrence by the Mobility Authority. In the event that any Governmental Approvals specify a procedure to be followed, the DB Contractor shall follow the procedure set forth in the Governmental Approvals. If the discovery of Differing Site Conditions necessitates a change in the design of the Project, such change shall be submitted to the Mobility Authority for its written approval.

14.9.3 The DB Contractor hereby acknowledges and agrees that it has assumed all risks with respect to the need to work around locations impacted by Differing Site Conditions. The DB Contractor shall bear the burden of proving that a Differing Site Condition exists and that it could not reasonably have worked around or mitigated the Differing Site Condition so as to avoid additional cost. The DB Contractor shall track all costs associated with a Differing Site Condition in accordance with the requirements and limitations in Section 14.7.

14.9.4 Each request for a Change Order relating to a Differing Site Condition shall be accompanied by a statement signed by a qualified professional setting forth all relevant assumptions made by the DB Contractor with respect to the condition of the Site, justifying the basis for such assumptions, explaining exactly how the existing conditions differ from those assumptions, and stating the efforts undertaken by the DB Contractor to find alternative design or construction solutions to eliminate or minimize the problem and the associated costs. No time extension or costs will be allowed in connection with any work stoppage in affected areas during the investigation period described above.

14.10 Force Majeure Events

Subject to the limitations contained in, and upon the DB Contractor's fulfillment of all applicable requirements of, this Section 14, the Mobility Authority shall issue Change Orders (a) to compensate the DB Contractor for additional costs incurred arising directly from Force Majeure Events (excluding Acceleration Costs or delay and disruption damages other than for any Force Majeure Events which are included in the definition of Mobility Authority-Caused Delay), and (b) to extend the applicable Completion Deadline, and/or Acceptance Deadline as the result of any delay in the Critical Path directly caused by a Force Majeure Event, to the extent that it is not possible to work around the problem.

14.10.1 Notwithstanding the foregoing, the DB Contractor shall be fully responsible for, and thus shall not receive a Change Order with respect to, any delays of up to 120 Days per location or an aggregate amount of 120 Days for all such delays, resulting from the need to work around locations impacted by the type of event described in clause (c) of the definition of "Force Majeure Event" (that is, the discovery of previously unknown archeological, paleontological or cultural resources on the Site). The Mobility Authority shall not be responsible for any Acceleration Costs or other costs attributable to any delays relating to such event or situation, other than any Acceleration Costs and other incremental costs directly attributable to the portion of the type of delay described above in excess of 120 Days per location or in excess of an aggregate amount of 120 Days for all such delays; provided that, the DB Contractor shall be entitled to a Change Order for additional costs and/or time only where there is a delay to the Critical Path after expiration of such 120 Day work-around period. If a delay resulting from the need to work around a previously unknown archeological, paleontological or cultural resource is concurrent with another delay which is the DB Contractor's responsibility hereunder, then such delay shall be borne 100% by the DB Contractor and shall not be counted towards the 120-Day aggregate cap. If a delay resulting from the need to work around a previously unknown archeological, paleontological or cultural resource is concurrent with another delay resulting from the need to work around another previously unknown archeological, paleontological or cultural resource, only one of the delays shall be applied to the 120-Day period of the DB Contractor's responsibility or the 120-Day aggregate cap. The foregoing shall not be deemed to preclude the DB Contractor from obtaining a Change Order with respect to any requirement that it perform mitigation measures relating to any such resources or materials which are not otherwise its responsibility under the terms of the Contract Documents.

14.11 **Eliminated Work**

Deletion of any Work shall not invalidate this DB Agreement or the bonds required under Section 9.

14.12 **Utility Adjustment Work**

The DB Contractor agrees that (a) the DB Price (as it may be increased pursuant to this Section 14.12) covers all of the Utility Adjustment Work and payments which are the DB Contractor's responsibility pursuant to Technical Provision 8 and/or in this Section 14.12, (b) it is feasible to obtain and/or perform all necessary Utility Adjustments within the time deadlines of the Contract Documents, and (c) the DB Price includes contingencies deemed adequate by the DB Contractor to cover the possibility that the Reference Documents do not accurately identify all Utilities impacted by the Project, taking into consideration the fact that the DB Contractor is entitled to Change Orders only in specified situations. Except as permitted by this Section 14.12, the DB Contractor assumes all risk of increased costs and of delays to the Project Schedule associated with the Utility Adjustment Work, without regard to who (as between the DB Contractor and the affected Utility Owner) is assigned the responsibility to perform such Utility Adjustment Work. Accordingly, subject to the limitations, restrictions and procedures set forth elsewhere in this Section 14, the DB Contractor shall be entitled to receive a Change Order for additional costs and delays associated with Utility Adjustment Work only as permitted by this Section 14.12 or in circumstances for which such a Change Order is otherwise permitted under the other provisions of this Section 14, such as for Mobility Authority-Directed Changes which increase the Utility Adjustment Work to be furnished, performed or paid for by the DB Contractor.

The DB Contractor's entitlement to any Change Orders pursuant to the other provisions of this Section 14 relating to the Utility Adjustment Work shall be subject to any applicable limitations and restrictions set forth in this Section 14.12, and the DB Contractor's entitlement to any Change Orders pursuant to this Section 14.12 shall be subject to the limitations, restrictions and procedures set forth elsewhere in this Section 14.

14.12.1 **Inaccuracies in Existing Utility Information**

The parties' entitlement to Change Orders on account of inaccuracies in the Existing Utility Information shall be determined in accordance with this Section 14.12.1.

14.12.1.1 The DB Contractor shall be entitled to an increase in the DB Price and the issuance of a Change Order in connection with increases in the cost of the Work due to Unidentified Utilities within the Schematic ROW. The amount of the DB Price increase in any Change Order issued under this Section 14.12.1.1 for each such Unidentified Utility facility shall be equal to the Cost Differential for that facility less \$50,000. By way of example, if the Cost Differential for a Unidentified Utility facility is \$75,000, the DB Contractor would be entitled to a \$25,000 Change Order, but if the Cost Differential related to a particular Unidentified Utility facility is less than \$50,000, then the DB Contractor would not be entitled to a Change Order. In no event shall the DB Contractor be required to pay more than an aggregate of \$150,000 with respect to Unidentified Utilities.

14.12.1.2 No time extension will be allowed on account of any delays attributable to any inaccuracy(ies) in the Existing Utility Information, except, subject to the limitations on time extensions in Section 14.3.1.1, for the discovery within the Schematic ROW of an Unidentified Utility.

14.12.1.3 All Cost Differential calculations submitted by the DB Contractor shall be supported by detailed cost proposals and supporting documentation (for all estimates used in such calculations) meeting the requirements of Section 14.6 of this DB Agreement. The Mobility Authority shall have the right to require that any or all of the information submitted by the DB Contractor in the EPDs be used in evaluating the cost proposals.

14.12.1.4 The DB Contractor shall use its Best Efforts to minimize costs for which the DB Contractor is entitled to compensation pursuant to this Section 14.12.1. Generally, such efforts will require avoidance of an Unidentified Utility where feasible rather than its removal and/or reinstallation in a new location; however, the DB Contractor may, upon the Mobility Authority's prior approval, remove and/or reinstall an Unidentified Utility in a new location even if avoidance is feasible, if the burden imposed on the DB Contractor by such avoidance would be unreasonable in light of the benefits to the Mobility Authority and the Project which would result therefrom. The provisions of this Section 14.12.1.4 are in all cases subject to the DB Contractor's obligation to comply with all applicable requirements of the Contract Documents, including the requirements described in Technical Provision 8.

14.12.2 **Utility Enhancements**

Utility Enhancements shall be addressed as provided in this Section 14.12.2 and in Technical Provision 8.

14.12.2.1 If a Utility Owner requests that the DB Contractor design and/or construct a Betterment, then subject to Section 14.12.2.4, the DB Contractor shall use its Best Efforts to negotiate in good faith an agreement with the Utility Owner providing for the DB Contractor to perform such work at the Utility Owner's expense, with payments to be made directly by the Utility Owner to the DB Contractor. Any such agreement shall be set forth in the applicable Utility Adjustment Agreement. Any such Betterment shall be deemed added to the scope of the Work upon execution by the Utility Owner and the DB Contractor and approval by the Mobility Authority of a Utility Adjustment Agreement or Utility Adjustment Agreement Amendment identifying and providing for performance of such Betterment. Any change in the scope of the Work pursuant to this Section 14.12.2.1 shall not be treated as a Mobility Authority-Directed Change. Except as otherwise set forth in this Section 14.12.2 or in Technical Provision 8, all the terms and conditions of the Contract Documents which apply to the Utility Adjustment Work being performed by the DB Contractor shall apply to any Betterment added to the Work pursuant to this Section 14.12.2.1.

14.12.2.2 The DB Price shall not be increased on account of any Betterment added to the Work. Instead, the DB Contractor shall have the right to collect payment for such work directly from the Utility Owner, subject to the provisions of the applicable Utility Adjustment Agreement or Utility Adjustment Agreement Amendment. The amount of compensation payable by the Utility Owner to the DB Contractor for a Betterment shall be determined pursuant to the process set forth in the applicable Utility Adjustment Agreement form in Exhibit D. The DB Contractor shall submit to the Mobility Authority a copy of each invoice delivered to a Utility Owner pursuant to this Section 14.12.2.2, concurrently with its delivery to the Utility Owner.

14.12.2.3 If a Utility Owner requests that the DB Contractor design and/or construct a Utility Owner Project, then subject to Section 14.12.2.4, the DB Contractor shall use its Best Efforts to negotiate in good faith an agreement with the Utility Owner providing for the DB Contractor to perform such work at the Utility Owner's expense, with payments to be made directly by the Utility Owner to the DB Contractor. Any such agreement shall be a separate construction contract between the DB Contractor and the Utility Owner; and any such Utility Owner Project shall be performed outside of this DB Agreement and the Work, without any impact on the DB Price. The compensation payable by the Utility Owner to the DB Contractor for a Utility Owner Project shall be determined in a manner acceptable to both the DB Contractor and the Utility Owner.

14.12.2.4 The DB Contractor is fully responsible for coordinating its efforts with Utility Owners and for addressing requests by Utility Owners that the DB Contractor design and/or construct Utility Enhancements. Under no circumstances shall the DB Contractor proceed with any Utility Enhancement which is incompatible with the Project or which cannot be performed within the other constraints of applicable Law, the Governmental Approvals and the Contract Documents, including the Completion Deadlines. Under no circumstances will the DB Contractor be entitled to any DB Price increase or time extension hereunder as the result of any Utility Enhancement, whether performed by the DB Contractor either outside of this DB Agreement or as part of the Work, or by the Utility Owner or its contractors. The DB Contractor shall promptly notify the Mobility Authority of any requests by Utility Owners which the DB Contractor considers to be Betterments, and shall keep the Mobility Authority informed as to the status of negotiations with Utility Owners concerning such requests. The DB Contractor shall

provide the Mobility Authority with such information, analyses, and certificates as may be requested by the Mobility Authority in order to determine compliance with this Section 14.12.2.

14.12.3 **Utility Agreements**

14.12.3.1 Utility Adjustment Agreements entered into by the DB Contractor (as the same may be amended, modified or supplemented) shall not be considered Contract Documents. Except as set forth in Section 14.12.5.4, the DB Contractor shall not be entitled to any increase in the DB Price or to any time extension on account of the terms of any Utility Adjustment Agreement or of any amendment, modification or supplement thereto.

14.12.3.2 Any Utility MOU's entered into by the Mobility Authority and/or TxDOT with Utility Owners are not Contract Documents, although the DB Contractor may have certain obligations with respect to such Utility MOU's as described in Technical Provision 8. The DB Contractor shall not be entitled to any increase in the DB Price or to any time extension on account of the terms of any Utility MOU entered into by TxDOT or the DB Contractor prior to the date of this DB Agreement.

14.12.4 **[Reserved]**

14.12.5 **Delays by Utility Owners**

14.12.5.1 The DB Contractor shall use Best Efforts to obtain the cooperation of each Utility Owner as necessary for the Project. The DB Contractor shall notify the Mobility Authority immediately if (a) the DB Contractor reasonably believes that any Utility Owner would not undertake or permit a Utility Adjustment in a manner consistent with the timely completion of the Project, (b) the DB Contractor becomes aware that a Utility Owner is not cooperating in a timely manner to provide the needed work or approvals, or (c) any other dispute arises between the DB Contractor and any Utility Owner with respect to the Project, despite the DB Contractor's diligent efforts to obtain such Utility Owner's cooperation or otherwise resolve such dispute. Such notice may include a request that the Mobility Authority assist in resolving the dispute or in otherwise obtaining the Utility Owner's timely cooperation. The DB Contractor shall provide the Mobility Authority with such information regarding the Utility Owner's failure to cooperate and the effect of any resulting delay on the Project Schedule as is requested by the Mobility Authority. The Mobility Authority's obligation to assist hereunder is subject to the DB Contractor's provision of evidence reasonably satisfactory to the Mobility Authority that the Adjustment is necessary, the time for completion of the Adjustment in the Project Schedule was, in its inception, a reasonable amount of time for completion of such Work, and that the DB Contractor has made Best Efforts to obtain the Utility Owner's cooperation but has not been able to obtain such cooperation. Following the receipt of such evidence by the Mobility Authority, the Mobility Authority shall take reasonable steps to obtain the cooperation of the Utility Owner or resolve the dispute; however, the Mobility Authority shall have no obligation to prosecute eminent domain or other legal proceedings, unless the Mobility Authority elects to do so in its sole discretion. After delivery of any notice or request for assistance pursuant to this Section 14.12.5.1, the DB Contractor shall continue to use Best Efforts to pursue the Utility Owner's cooperation. Any assistance provided by the Mobility Authority shall not relieve the DB Contractor of its sole and primary responsibility for the satisfactory compliance with its obligations and timely completion of all Utility Adjustment Work, except as otherwise expressly set forth in this Section 14.12.5.

14.12.5.2 In the event that the Mobility Authority objects in writing to the DB Contractor's request for assistance pursuant to Section 14.12.5.1, based on the DB Contractor's failure to satisfy the Mobility Authority that (a) the Adjustment is necessary for the Project, (b) the time for completion of the Adjustment in the Project Schedule was, in its inception, a reasonable amount of time for completion of such Work, (c) the DB Contractor has made diligent efforts to obtain the Utility Owner's cooperation, or (d) the Utility Owner is not cooperating, the DB Contractor shall take such action as the DB Contractor deems advisable during the next 45 days to obtain the Utility Owner's cooperation and shall then have the right to submit another request for assistance with an Adjustment. This process shall be followed until the DB Contractor succeeds in obtaining the Utility Owner's cooperation or in otherwise resolving the dispute or until the Mobility Authority determines, based on evidence presented by the DB Contractor, that the Adjustment is necessary, the DB Contractor has made diligent efforts to obtain the Utility Owner's cooperation and the Utility Owner is uncooperative. The DB Contractor shall have the right to submit the question of the reasonableness of the Mobility Authority's determination through the dispute resolution process described in Section 25.

14.12.5.3 The DB Contractor shall bear 100% of the risk of Critical Path delays caused by a Utility Owner's failure to timely comply with the requirements of a Utility Adjustment Agreement which has been executed by the DB Contractor, TxDOT or the Mobility Authority and such Utility Owner.

14.12.5.4 The DB Contractor shall bear 100% of the risk of each Utility Owner Delay prior to and during the first 90 days of any such Utility Owner Delay, provided that such 90-day period shall not commence until the Mobility Authority has received evidence required by Section 14.12.5.1 that is reasonably satisfactory to the Mobility Authority and the DB Contractor has complied with all other requirements for a Change Order under this DB Agreement. The risk of any Utility Owner Delay after such 90-day period shall be borne equally by each Party (i.e., any affected Completion Deadline or Acceptance Deadline shall be extended by one day for every two full days of Utility Owner Delay occurring after expiration of the 90-day period). If a Utility Owner Delay is concurrent with another delay which is the DB Contractor's responsibility hereunder, the DB Contractor shall not be entitled to a time extension on account of such Utility Owner Delay. If a Utility Owner Delay is concurrent with another Utility Owner Delay by the same Utility Owner or by another Utility Owner, only one of the delays shall be counted.

14.12.5.5 No Change Order for delay to the Critical Path shall be allowable pursuant to Section 14.12.5.4 unless all of the following criteria are met:

- (a) the general requirements and conditions for Change Orders have been met;
- (b) the DB Contractor has provided evidence reasonably satisfactory to the Mobility Authority that (i) the DB Contractor took advantage of Float time available early in the Project Schedule for coordination activities with respect to the affected Utility and (ii) the DB Contractor has made diligent efforts to obtain the Utility Owner's cooperation but has been unable to obtain such cooperation;
- (c) if applicable, the DB Contractor has provided a reasonable Utility Adjustment plan to the Utility Owner;

(d) the DB Contractor or the Utility Owner has obtained, or is in a position to timely obtain, all applicable approvals, authorizations, certifications, consents, exemptions, filings, leases, licenses, permits, registrations, opinions and rulings required by or with any Person in order to design and construct such Utility Adjustment;

(e) no other circumstance exists that would delay the affected Utility Adjustment even if the Utility Owner were cooperative; and

(f) the delay is allowable under Section 14.5.3.

14.12.5.6 Except as set forth in Section 14.12.5.4, the DB Contractor shall not be entitled to extension of the Completion Deadline or the Acceptance Deadline on account of any delays caused by a Utility Owner. The DB Contractor shall not be entitled to any increase of the DB Price or reimbursement of any additional costs which it may incur as a result of any delays caused by a Utility Owner, regardless of whether the DB Contractor is entitled to an extension of the Completion Deadline or the Acceptance Deadline on account of such delays pursuant to Section 14.12.5.4. Any action or inaction by the Mobility Authority as described in Section 14.12.5.1 shall have no bearing on the restriction set forth in this Section 14.12.5.6.

14.12.6 Amounts Owed by Utility Owners to the DB Contractor

If for any reason the DB Contractor is unable to collect any amounts owed to the DB Contractor by a Utility Owner (whether for a Utility Enhancement or otherwise): (a) the Mobility Authority shall have no liability for such amounts; (b) the DB Contractor shall have no right to collect such amounts from the Mobility Authority or to offset such amounts against amounts otherwise owing from the DB Contractor to the Mobility Authority; and (c) the DB Contractor shall have no right to stop work or to exercise any other remedies against the Mobility Authority on account of such Utility Owner's failure to pay the DB Contractor.

14.12.7 Additional Restrictions on Change Orders

In addition to all of the other requirements and limitations contained in this Section 14.12 and in the other provisions of this Section 14, the rights and obligations of the DB Contractor under this Section 14.12 shall be subject to the following:

14.12.7.1 As part of the Work, the DB Contractor is responsible for causing all Utility Adjustment Work to occur, for reimbursing the Utility Owners for their costs of performing or furnishing Utility Adjustment Work (excluding the cost of Utility Enhancements), and for scheduling all Utility Adjustment Work (whether performed by the DB Contractor or the affected Utility Owner) so as to meet the Completion Deadline and the Acceptance Deadline herein. Accordingly, if a Utility Owner performs or furnishes Utility Adjustment Work that was initially anticipated to be performed or furnished by the DB Contractor, or if the DB Contractor performs or furnishes Utility Adjustment Work that was initially anticipated to be performed or furnished by the Utility Owner, there shall be no resulting time extension and no resulting change in the DB Price (either up or down).

14.12.7.2 Except as set forth in Section 14.12.5.4, the DB Contractor assumes all risk of, and shall not be entitled to receive any time extension or increase in the DB Price on account of, any delays caused by any Utility Owner. The DB Contractor shall not be entitled to

receive any time extension or increase in the DB Price on account of any failure by a Utility Owner to comply with the terms and conditions of any Utility MOU. Any action or inaction by the Mobility Authority as described in Section 14.12.5.1 shall have no bearing on the restriction set forth in this Section 14.12.7.2.

14.12.7.3 The DB Contractor shall not be entitled to a Change Order for any costs or delays which it may incur that are attributable to (a) any errors, omissions, inaccuracies, inconsistencies or other defects in designs furnished by any Utility Owner, and/or (b) any defect in construction performed by any Utility Owner.

14.12.7.4 Except as set forth in Section 14.12.5.4, the DB Contractor shall not be entitled to a Change Order for any costs or delays resulting from the performance of Utility Adjustment Work (including Incidental Utility Adjustment Work) by the DB Contractor or any Utility Owner (including with respect to Unidentified Utilities).

14.12.7.5 Any Change Order increasing the DB Price pursuant to this Section 14.12 shall include only the incremental costs arising from the circumstances giving rise to such Change Order.

14.12.7.6 The DB Contractor shall not be entitled to any increase in the DB Price for any costs of coordinating with Utility Owners (including with respect to Unidentified Utilities).

14.12.7.7 Any information with respect to Utilities provided in the Existing Utility Information or in any other materials included in the Reference Documents is for the DB Contractor's reference only, has not been verified, and shall not be relied upon by the DB Contractor, except as expressly set forth in Section 14.12.1. Accordingly, the DB Contractor shall not be entitled to any increase in the DB Price or to any time extension on account of any inaccuracies in the Reference Documents with respect to any Identified Utilities. Further, the DB Contractor shall not be entitled to any increase in the DB Price on account of inaccuracies in the Reference Documents with respect to Unidentified Utilities except to the extent that they are reflected in the calculation of the Cost Differential for Unidentified Utilities as described in Exhibit A to this DB Agreement (and subject to the thresholds and any other limitations set forth in Section 14.12.1). Without limiting the generality of the foregoing, except as set forth in the preceding sentence, the DB Contractor shall not be entitled to any increase in the DB Price and/or time extension as a result of any of the following:

(a) Any increase in the extent or change in the character of the Utility Adjustment Work necessary to Adjust any Utility from that anticipated by the DB Contractor;

(b) Any difference in the cost to Adjust a Utility from that anticipated by the DB Contractor;

(c) Any inaccuracy in the information included in the Reference Documents as to the existence, location, ownership, type, and/or any other characteristic of any Utility;

(d) Any inaccuracy in the Reference Documents as to whether any Utility is located within privately owned property or public right of way; and/or

(e) Any inaccuracy in the Reference Documents as to the existence or nature of any rights or interests relating to the occupancy of any real property by any Utility.

14.12.7.8 If the DB Contractor elects to make payments to Utility Owners or to undertake any other efforts which are not required by the terms of the Contract Documents, the DB Contractor shall not be entitled to a Change Order in connection therewith.

14.13 Restrictions and Limitations on Change Orders

The DB Contractor acknowledges and agrees that the Mobility Authority shall bear responsibility only for limited matters involving delays and costs and the consequences resulting therefrom as set forth in this Section 14. The DB Contractor shall bear responsibility for all other matters, including, but not limited to, the following:

(a) Errors, omissions, inaccuracies, inconsistencies or other defects in the Contract Documents, including, but not limited to, the Schematic Plan and any requests for Change Orders;

(b) Any design changes requested by the Mobility Authority as part of the process of overseeing and accepting the Design Documents for consistency with the requirements of the Contract Documents, TxDOT, FHWA or other Governmental Approvals and/or applicable Law;

(c) Defective or incorrect schedules of Work or changes in the planned sequence of performance of the Work;

(d) Action or inaction of Subcontractors or sub-subcontractors (including failure to organize and integrate their work with the Work);

(e) Subsurface moisture content and Site conditions (including geological, soil conditions, ground elevations and/or topography differing from those indicated in the Contract Documents), except to the extent that the Mobility Authority has agreed in Section 14.9 to be responsible for any such conditions which constitute Differing Site Conditions;

(f) Untimely delivery of equipment or material, or unavailability or defectiveness or increases in costs of material, equipment or products specified by the Contract Documents, except to the extent resulting from a Force Majeure Event;

(g) All costs covered by insurance proceeds received by or on behalf of the DB Contractor;

(h) Correction of Nonconforming Work and review and acceptance thereof by the Mobility Authority, including rejected design submittals;

(i) Failure by any member of the DB Contractor Group to comply with the requirements of the Contract Documents, the Governmental Approvals and/or applicable Law;

(j) Any delay not on a Critical Path;

(k) Delays or costs arising out of, related to or caused by Adjacent Work;

(l) Delays in issuance of any Governmental Approval by any entity with jurisdiction over the subject matter of such Governmental Approval that is required to be obtained by the DB Contractor, except to the extent resulting from a Force Majeure Event;

(m) Delays caused by untimely provision of access to Final ROW, except to the extent the Mobility Authority has agreed in this Section 14 to be responsible for any such delays which constitute Mobility Authority-Caused Delays;

(n) Delays from any other situations (other than Force Majeure Events) which, while not within one of the categories delineated above, were or should have been anticipated by the DB Contractor because such situations are referred to elsewhere in this DB Agreement or arise out of the nature of the Work; and

(o) All events beyond the control of the Mobility Authority for which the Mobility Authority has not expressly agreed to assume liability hereunder.

The DB Contractor assumes responsibility for all such matters, and acknowledges and agrees that assumption by the DB Contractor of responsibility for such costs and delays, and the consequences and costs resulting therefrom, is reasonable under the circumstances of this DB Agreement. THE DB CONTRACTOR EXPRESSLY WAIVES ALL RIGHTS TO ASSERT ANY AND ALL CLAIMS BASED ON ANY CHANGE IN THE WORK, DELAY OR ACCELERATION, INCLUDING ANY CONSTRUCTIVE CHANGE, DELAY, SUSPENSION OR ACCELERATION, FOR WHICH THE DB CONTRACTOR FAILED TO PROVIDE PROPER AND TIMELY NOTICE AS REQUIRED BY SECTION 14.3 OR FAILED TO PROVIDE A TIMELY CHANGE ORDER FORM AS REQUIRED BY SECTION 14.3, AND AGREES THAT THE DB CONTRACTOR SHALL BE ENTITLED TO NO CHANGE ORDER, COMPENSATION, DAMAGES OR TIME EXTENSIONS WHATSOEVER IN CONNECTION WITH THE WORK EXCEPT TO THE EXTENT THAT THE CONTRACT DOCUMENTS EXPRESSLY SPECIFY THAT THE DB CONTRACTOR IS ENTITLED TO A CHANGE ORDER, COMPENSATION, DAMAGES OR A TIME EXTENSION.

14.14 Disputes

The failure of the Mobility Authority and the DB Contractor to agree to any Change Order under this Section 14 shall be a dispute to be resolved pursuant to Section 25 of this DB Agreement. Except as otherwise specified in the Change Order, execution of a Change Order by the Parties shall be deemed accord and satisfaction of all claims by the DB Contractor of any nature arising from or relating to the Work covered by the Change Order.

14.15 No-Cost Changes

Changes in the Work which have no net cost effect on the DB Price and do not involve a material change in the scope of the DB Work, may be approved in writing by the Mobility Authority as a Deviation, and in such event shall not require a Change Order. The Mobility Authority's determination as to whether a change in scope is material shall be subject to concurrence by TxDOT and FHWA.

14.16 No Release or Waiver

14.16.1 No extension of time granted hereunder shall release or discharge any Surety or Guarantor from its obligations. Work shall continue and be carried on in accordance with all the provisions of the Contract Documents, unless formally suspended or annulled in accordance with the terms hereof. Permitting the DB Contractor to finish the Work or any part thereof after the applicable Completion Deadline or the applicable Acceptance Deadline, or the making of payments to the DB Contractor after such date, shall not constitute a waiver on the part of the Mobility Authority of any rights under this DB Agreement.

14.16.2 The Mobility Authority shall not be deemed to have waived any rights hereunder (including its right to abrogate this DB Agreement for abandonment or for failure to complete within the time specified, or to impose and deduct damages as may be provided herein) as the result of any grant of an extension of time beyond the date fixed for the completion of any part of the Work, any acceptance of performance of any part of the Work after the deadline therefor, or the making of any payments to the DB Contractor after such date.

14.17 Concurrence by TxDOT and FHWA Representatives

An authorized representative of both TxDOT and FHWA must concur in any Change Order entered into by the parties pursuant to this DB Agreement. Prior approval of FHWA is required for any Major Change Order.

14.18 Discovery of Karst Features

In the event karst features are discovered within the Site, the DB Contractor shall comply with and shall cause all Persons performing Work to comply with Technical Provision 9 with respect to the relevant karst features. The DB Contractor shall be deemed to have waived the right to collect any and all costs incurred in connection with any karst features and any right to obtain an extension of a Completion Deadline in connection with any karst features if the Mobility Authority is not provided written notice of the discovery of the karst feature and afforded the opportunity to inspect sites containing the karst feature before any action is taken that would inhibit the Mobility Authority's ability to ascertain, based on a site inspection, the nature and extent of the mitigation work required for such karst feature.

14.18.1 Price Increase

Subject to the limitations, restrictions and procedures set forth elsewhere in this Section 14 and this Section 14.18, the DB Contractor shall be entitled to an increase in the DB Price as follows: (a) 50% of the DB Contractor's Reimbursable Karst Features Costs for karst features encountered by the DB Contractor that exceed \$500,000 but do not exceed \$1,250,000; (b) 100% of Reimbursable Karst Features Costs for karst features encountered by the DB Contractor that exceed \$1,250,000; and (c) 100% of Reimbursable Karst Features Costs for karst features encountered on Additional Properties acquired as a result of a Mobility Authority-Directed Change. The DB Contractor shall be responsible for all other costs related to karsts.

14.18.2 Determination of Reimbursable Amount

The term "Reimbursable Karst Features Costs" shall mean the incremental reasonable, out-of-pocket Direct Costs incurred for mitigating karst features (deducting any avoided costs), including any re-design and construction costs for affected roadway elements, and shall not include indirect costs, including overhead and barricades; provided, however, that "Reimbursable Karst Features Costs" shall only include such costs related to any individual karst feature if (a) such costs exceed \$10,000 for such individual karst feature or (b) such costs do not exceed \$10,000 for such individual karst feature and the DB Contractor has mitigated more than 50 individual karst features that did not result in Reimbursable Karst Features Costs because such \$10,000 threshold was not met. The costs of investigating and characterizing karst features and preparing any karst feature mitigation plans are included in the DB Price, and the DB Contractor shall not be entitled to additional compensation therefor.

The DB Contractor shall take all reasonable steps to minimize any Reimbursable Karst Features Costs.

14.18.3 Time Extensions

Subject to the limitations, restrictions and procedures set forth elsewhere in this Section 14 and this Section 14.18, the DB Contractor shall be entitled to extend applicable Completion Deadlines for delays to a Critical Path attributable to the development, review and approval of a karst feature mitigation plan for an karst feature ("Karst Plan Delay"). A Karst Plan Delay begins on the date the DB Contractor notifies TCEQ and the Mobility Authority of the discovery of an karst feature in accordance with Technical Provision 9 and ends when the applicable karst feature mitigation plan is approved by the Mobility Authority and TCEQ. The DB Contractor shall bear 100% of the risk of Karst Plan Delays up to 35 days per individual karst feature and up to a cumulative total of 180 days for all karst features locations. If the Karst Plan Delay exceeds 35 days for a particular karst feature, then the risk of such Karst Plan Delay in excess of 35 days for that karst feature shall be borne by the Mobility Authority. If aggregate Karst Plan Delays for which the DB Contractor is 100% responsible exceed 180 days, then the risk of Karst Plan Delays in excess of 180 days shall be borne by the Mobility Authority. If a Karst Plan Delay is concurrent with another delay that is the DB Contractor's responsibility under this DB Agreement, then the DB Contractor shall bear 100% of the risk of such Karst Plan Delay and the delay to the Critical Path shall not be counted towards the 180-day aggregate cap described in this Section 14.18.3. If a Karst Plan Delay at one location is concurrent with another Karst Plan Delay at one or more other locations, the 35-day period of the DB Contractor's responsibility for the delays at the

locations shall run concurrently and only one of the concurrent Karst Plan Delays shall apply to the 180-day cap. The DB Contractor shall not be entitled to an extension of any Completion Deadlines for any delays resulting from the discovery of karst features prior to submission of a notice to both the Mobility Authority and TCEQ of the discovery of a karst feature in accordance with this Section 14.18.3.

Subject to the limitations, restrictions and procedures set forth elsewhere in this Section 14 and this Section 14.18, the DB Contractor shall be entitled to an extension of applicable Completion Deadlines for delays to a Critical Path attributable to the execution of an approved karst feature mitigation plan for a karst feature (“Karst Mitigation Delay”). A Karst Mitigation Delay begins on the date the DB Contractor commences karst feature mitigation activities following approval of the karst feature mitigation plan for the applicable karst feature by TCEQ and the Mobility Authority and ends when the DB Contractor completes such karst feature mitigation activities in accordance with the karst feature mitigation plan. The risk of Karst Mitigation Delays shall be borne equally by each Party (i.e., any affected Completion Deadline shall be extended by one day for every two full days of Karst Mitigation Delays). If a Karst Mitigation Delay is concurrent with another delay that is the DB Contractor’s responsibility under the DB Agreement, then the DB Contractor shall bear 100% of the risk of such Karst Mitigation Delay. If a Karst Mitigation Delay at one location is concurrent with another Karst Mitigation Delay at one or more other locations, the delays at the locations shall run concurrently and each day of such concurrent delay shall be deemed a single day of Karst Mitigation Delay.

The foregoing shall not be deemed to preclude the DB Contractor from obtaining a Change Order entitling the DB Contractor to additional compensation and/or extension of time for any event described in clause (d) of the definition of "Force Majeure Event" (that is, the discovery of any species listed as threatened or endangered under the federal or state endangered species act or similar Law), which shall be deemed to have occurred at the time of discovery of such species.

14.18.4 Limitations on Change Orders for Discovery of Karst Features

Entitlement to compensation or a time extension for the mitigation of karst features shall be limited to Work performed pursuant to the DB Contractor’s karst feature mitigation plans for such karst features, as approved by the Mobility Authority in writing. The DB Contractor shall demonstrate to the Mobility Authority’s satisfaction that the DB Contractor’s karst feature mitigation plans represent the approach that is most beneficial to the Project and the public. The DB Contractor shall provide the Mobility Authority with such information, analyses and certificates as may be requested by the Mobility Authority in order to enable a determination regarding eligibility for an increase to the DB Price or a time extension with respect to a karst feature. Notwithstanding anything to the contrary in the Contract Documents, no compensation or time extension shall be allowed with respect to: (a) any karst features that could have been avoided by reasonable design modifications or construction techniques; (b) any costs that could have been avoided; or (c) karst features on any of the DB Contractor-Designated ROW. The DB Contractor shall not be entitled to delay or disruption damages resulting from a Karst Plan Delay or Karst Mitigation Delay.

15. SUSPENSION OF ALL OR PART OF THE WORK

15.1 Suspension for Convenience

The Mobility Authority may order the DB Contractor in writing to suspend, delay, or interrupt all or any part of the Work for a period of time not to exceed 24 hours, as the Mobility Authority may determine to be appropriate for the convenience of the Mobility Authority provided that such notice, to be effective, must be given at least 48 hours prior to the suspension. Any suspension for convenience in excess of 24 hours which results in a delay to the Critical Path will be considered a Mobility Authority-Directed Change.

15.2 Suspension for Other Reasons, Including Compliance with Governmental Approvals

The Mobility Authority has the authority to suspend the Work wholly or in part for such period as the Mobility Authority deems necessary because of the failure on the part of any member of the DB Contractor Group to carry out orders given or to perform any requirements of the Contract Documents, the Governmental Approvals or applicable Law. The DB Contractor shall promptly comply with the written order of the Mobility Authority to suspend the Work wholly or in part. The suspended Work shall be resumed when corrective action satisfactory to the Mobility Authority has been taken.

15.3 Compensation and Time Extensions for Suspensions

The DB Contractor shall not be entitled to any increase in the DB Price or extension of the Completion Deadline or Acceptance Deadline in connection with any suspension under this *Section 15*, except to the extent that the suspension is considered to be a Mobility Authority-Directed Change under *Section 15.1*. In such event, the DB Contractor may be entitled to compensation and/or a time extension in accordance with *Section 14*.

16. TERMINATION FOR CONVENIENCE

16.1 DB Contractor's Right to Terminate for Delay in Project Financing

16.1.1 Subject to *Section 13.2*, the DB Contractor shall have the right to unilaterally terminate its obligations under this DB Agreement if NTP2 has not been issued by the Mobility Authority on or before 365 Days after the Proposal Date, due to no fault of any member of the DB Contractor Group.

16.1.2 The DB Contractor shall have no right to unilaterally terminate any Contract Documents after the issuance of NTP2, including in the case of material default by the Mobility Authority or delay in satisfaction of conditions precedent to commencing construction, except as set forth in *Section 17.4*.

16.2 Mobility Authority's Right to Terminate for Convenience

The Mobility Authority may, in its sole discretion, terminate the DB Contractor's rights and obligations under the Contract Documents at any time subject to the provisions of this *Section 16*.

16.3 Notice of Termination

The Mobility Authority shall notify the DB Contractor of its decision to terminate for convenience by delivering to the DB Contractor a written notice of termination ("**Notice of Termination**") specifying the extent of termination and its effective date. Termination (or partial termination) of this DB Agreement shall not relieve or release any Surety or Guarantor of its obligation for any claims arising out of the Work performed as of the effective date of the termination (or thereafter in the case of a partial termination).

16.4 DB Contractor's Responsibilities After Receipt of Notice of Termination

After receipt of a Notice of Termination, and except as otherwise directed in writing by the Mobility Authority, the DB Contractor shall immediately proceed as follows, regardless of any delay in determining or adjusting any amounts due under this Section 16:

16.4.1 Stop Work as specified in the notice;

16.4.2 Enter into no further Subcontracts or Utility Adjustment Agreements without the consent of the Mobility Authority;

16.4.3 Terminate all Subcontracts and Utility Adjustment Agreements to the extent they relate to the Work terminated except to the extent that continuation of the Subcontract or Utility Adjustment Agreement is necessary in order to mitigate damages;

16.4.4 Assign to the Mobility Authority or its designee, in the manner, at the times, and to the extent directed by the Mobility Authority, all of the DB Contractor's right, title, and interest in the Subcontracts and Utility Adjustment Agreements so terminated, in which case the Mobility Authority will have the right, in its sole discretion, to settle or pay any or all claims arising out of the termination of such Subcontracts and Utility Adjustment Agreements;

16.4.5 Settle all outstanding liabilities and claims arising out of such termination of Subcontracts and Utility Adjustment Agreements, with the approval or ratification of the Mobility Authority;

16.4.6 Assign to the Mobility Authority or its designee, in the manner, at the times, and to the extent directed by the Mobility Authority, all of the DB Contractor's right, title, and interest in any Utility Adjustment Agreements which relate to the terminated Work but which the Mobility Authority has directed the DB Contractor not to terminate;

16.4.7 Transfer title and deliver to the Mobility Authority or its designee, in the manner, at the times, and as and to the extent, if any, directed by the Mobility Authority, (a) the Work in process, completed Work, supplies and other material produced or acquired for the Work subject to the Notice of Termination for which payment has been made by the Mobility Authority, and (b) the Design Documents, Construction Documents and all other completed or partially completed drawings (including Plans, elevations, sections, details and diagrams), specifications, records, samples, information studies, reports, calculations, CADD files, and other property for which payment has been made by the Mobility Authority that would have been required to be furnished to the Mobility Authority if the Work had been completed;

16.4.8 Complete performance in accordance with the Contract Documents of all Work not terminated;

16.4.9 Take all action that may be necessary, or that the Mobility Authority may direct, for the protection and preservation of (a) the Project, (b) the Work and (c) the equipment, machinery, materials and property related to the Project, the Work and the Contract Documents that is in the possession of the DB Contractor and in which the Mobility Authority (or any Utility Owner) has or may acquire an interest; and

16.4.10 Subject to the written approval of the Mobility Authority, use its Best Efforts to sell, in a manner, at the times, at the price or prices and to the extent directed or authorized by the Mobility Authority, any property of the types referred to in clause (a) of Section 16.4.7; provided, however, that the DB Contractor (a) is not required to extend credit to any purchaser, and (b) may acquire the property under the conditions prescribed and at prices approved by the Mobility Authority. The proceeds of any transfer or disposition will be applied to reduce any payments to be made by the Mobility Authority under the Contract Documents or paid in any other manner directed by the Mobility Authority.

16.5 Inventory

The DB Contractor shall submit to the Mobility Authority a list of machinery, equipment, materials and inventory not previously disposed of and excluding items authorized for disposition by the Mobility Authority; and within 45 Days after delivery of the list, the DB Contractor shall deliver such items to the Mobility Authority and the Mobility Authority shall accept title to such items, except as otherwise directed by the Mobility Authority.

16.6 Settlement Proposal

After receipt of a Notice of Termination, the DB Contractor shall submit a final termination settlement proposal to the Mobility Authority in the form and with the certification prescribed by the Mobility Authority. The DB Contractor shall submit the proposal promptly, but no later than 90 Days from the effective date of termination unless the DB Contractor has requested a time extension in writing within such 90-Day period and the Mobility Authority has agreed in writing to such extension. If the DB Contractor fails to submit the proposal within the time allowed, the Mobility Authority may conclusively determine, on the basis of information available to it, the amount, if any, due to the DB Contractor because of the termination and shall pay the DB Contractor the amount so determined. The provisions of Section 17 shall govern any termination of this DB Agreement as a result of an Event of Default.

16.7 Amount of Termination Settlement

Subject to the provisions of Section 16.6, the DB Contractor and the Mobility Authority may agree upon the amount to be paid to the DB Contractor by reason of the total or partial termination of Work pursuant to this Section 16. Such negotiated settlement may include a reasonable allowance for profit solely on Work which has been completed and accepted by the Mobility Authority as of the termination date. Such agreed amount, exclusive of settlement costs, shall not exceed the DB Price less the amount of payments previously made to the DB Contractor and less the portions of the DB Price related to Work not terminated; provided, however, that if a termination occurs prior to issuance by the Mobility Authority of NTP1, no amount shall be

payable to the DB Contractor. Upon determination of the settlement amount, the DB Contractor will be paid the agreed amount and this DB Agreement will be amended accordingly to implement the partial or total termination. The Mobility Authority's execution and delivery of any settlement agreement shall not affect any of its rights under the Contract Documents with respect to completed Work, relieve the DB Contractor from its obligations with respect thereto, including Warranties, or affect the Mobility Authority's rights under the Performance Bonds and/or the Payment Bonds.

16.8 No Agreement as to Amount of Claim

If the DB Contractor and the Mobility Authority fail to agree, as provided in Section 16.7, upon the amount to be paid to the DB Contractor by reason of the termination of Work pursuant to this Section 16, the amount payable shall be determined pursuant to the procedures set forth in Section 25.

16.9 Reduction in Amount of Claim

The amount otherwise due to the DB Contractor under this Section 16 shall be reduced by (a) all unliquidated advances or other payments made to or on behalf of the DB Contractor with respect to any portion of the Work or this DB Agreement that has been terminated, (b) the amount of any claim which the Mobility Authority may have against any member of the DB Contractor Group in connection with this DB Agreement; (c) the amount of any Losses suffered by any Indemnified Party as a result of the actions, omissions, negligence, willful misconduct, or breach of applicable Law or contract by any member of the DB Contractor Group; (d) any existing or threatened claims, Liens and stop notices relating to the Project; (e) the agreed price for, or the proceeds of sale of, any materials, supplies or other things acquired by the DB Contractor or sold, pursuant to the provisions of this Section 16, and not otherwise recovered by or credited to the Mobility Authority; and (f) any amounts due or payable by the DB Contractor to the Mobility Authority, plus any interest accrued thereon under the terms of this DB Agreement. The DB Contractor does not hereby waive any right to payment of amounts it may be owed to the extent withheld by the Mobility Authority pursuant to this Section 16.9.

16.10 Preservation of Records

Unless otherwise provided for in this DB Agreement or by applicable Law, the DB Contractor shall, from the effective date of termination until the expiration of five years after final settlement under this DB Agreement, preserve and make available to the Mobility Authority at no cost to the Mobility Authority and at all reasonable times, all of its books, records, electronic files, documents and other evidence relating to the costs and expenses of the DB Contractor under this DB Agreement and relating to the Work terminated hereunder, or, to the extent approved by the Mobility Authority, photographs, micrographs, or other authentic reproductions thereof.

16.11 Mobility Authority's Unilateral Right to Issue NTPs

16.11.1 Notwithstanding the foregoing, the DB Contractor acknowledges and agrees that the Mobility Authority has no obligation to issue either NTP1 or NTP2 hereunder. Furthermore, the DB Contractor acknowledges that any decision to issue NTP1 or NTP2 shall be in the sole discretion of the Mobility Authority.

17. DEFAULT

17.1 Default of the DB Contractor

17.1.1 The DB Contractor shall be in default under this DB Agreement upon the occurrence and continuance of any one or more of the following events or conditions, following notice and opportunity to cure (if applicable) as specified in Section 17.1.2:

(a) The DB Contractor fails either (i) to begin any portion of the Work under the Contract Documents following issuance of an NTP therefor, or (ii) to prosecute the Work in accordance with a Project Schedule that has been agreed to by the parties; or

(b) The DB Contractor fails to perform the Work with sufficient resources to assure Substantial Completion within 180 Days following the Completion Deadline and Final Acceptance within 180 Days following the Acceptance Deadline; or

(c) The DB Contractor fails to perform and complete the Work in accordance with the Contract Documents, the Governmental Approvals and applicable Law, or refuses to repair, remove and replace defective or rejected materials, Nonconforming Work or Work that fails to conform with the requirements of the Contract Documents; or

(d) The DB Contractor suspends, ceases, stops or abandons the Work or fails to continuously and diligently prosecute the Work, excluding any work stoppage (i) due to termination by the Mobility Authority, (ii) due to and during the continuance of a Force Majeure Event or suspension by the Mobility Authority pursuant to Section 15.1; or (iii) due to and during the continuance of any suspension of work under Section 17.4.

(e) The DB Contractor fails to resume performance of Work which has been suspended or stopped, within a reasonable time after receipt of notice from the Mobility Authority to do so or after cessation of the event preventing performance; or

(f) The DB Contractor fails to maintain the insurance required under Section 10 or fails to provide the Performance Bond, or the Payment Bond; or

(g) The DB Contractor breaches any other covenant, agreement, obligation, term or condition contained in the Contract Documents which is not otherwise specifically referenced in this Section 17.1.1; or

(h) The DB Contractor assigns or transfers the Agreement or any right or interest herein, except as expressly permitted hereunder; or

(i) The DB Contractor fails to discharge or obtain a stay within 10 days of any final judgment(s) or order for the payment of money against it in excess of \$100,000 in the aggregate arising out of the prosecution of the Work; provided, however, that the posting of a bond in the amount of 125% of such judgment or order shall be deemed an effective stay; or

(j) The DB Contractor fails, absent a valid dispute, to make payment when due for labor, equipment or materials in accordance with its agreements with Subcontractors and applicable Law; or

(k) Any representation or warranty made by the DB Contractor or any Guarantor in the Contract Documents or any certificate, schedule, instrument, or other document delivered pursuant to the Contract Documents shall have been false or misleading when made; or

(l) The DB Contractor or any Guarantor is a party to fraud; or

(m) Any Guarantor revokes or attempts to revoke its obligations under its guarantee or otherwise takes the position that such instrument is no longer in full force and effect; or

(n) The DB Contractor or any equity member of the DB Contractor (each a "**DB Contractor Party**") commences a voluntary case seeking liquidation, reorganization or other relief with respect to itself or its debts under any bankruptcy, insolvency or other similar Law now or hereafter in effect; seeks the appointment of a trustee, receiver, liquidator, custodian or other similar official of such DB Contractor Party or any substantial part of such DB Contractor Party's assets; files an answer admitting the material allegations of a petition filed against such DB Contractor Party in any involuntary case commenced against the DB Contractor Party; consents to any such relief or to the appointment of or taking possession by any such official in any voluntary case commenced against such DB Contractor Party; makes an assignment for the benefit of creditors; fails, is unable, or admits in writing the inability generally to pay such DB Contractor Party's debts as they become due; or takes any action to authorize any of the foregoing; or any of the foregoing acts or events shall occur with respect to Guarantor; or

(o) An involuntary case is commenced against a DB Contractor Party seeking liquidation, reorganization, dissolution, winding up, a composition or arrangement with creditors, a readjustment of debts or other relief with respect to such DB Contractor Party or such DB Contractor Party's debts under any bankruptcy, insolvency or other similar Law now or hereafter in effect; seeking the appointment of a trustee, receiver, liquidator, custodian or other similar official of such DB Contractor Party or any substantial part of such DB Contractor Party's assets; seeking the issuance of a writ of attachment, execution, or similar process; or seeking like relief, and such involuntary case shall not be contested by such DB Contractor Party in good faith or shall remain undismissed and unstayed for a period of sixty (60) Days; or any such involuntary case or cases shall be commenced against Guarantor (but not necessarily in the same proceeding or concurrently) and such case or cases shall not be contested by Guarantor in good faith or shall remain undismissed and unstayed for a period of sixty (60) Days; or

(p) The DB Contractor fails to timely submit to the Mobility Authority a Project Schedule as required under the Contract Documents.

(q) The DB Contractor is unable to provide the Debarment Certificate required pursuant to Section 13.3.2(j) in connection with a Draw Request.

17.1.2 The DB Contractor and Surety shall be entitled to thirty (30) Days' written notice and opportunity to cure any breach before declaring an Event of Default, provided that no such notice and opportunity to cure is required for any breach which by its nature cannot be cured. Failure to provide notice to Surety shall not preclude the Mobility Authority from exercising its remedies against the DB Contractor. If a breach is capable of cure but, by its nature, cannot be cured within thirty (30) Days, as determined by the Mobility Authority, such additional period of

time shall be allowed as may be reasonably necessary to cure the breach so long as the DB Contractor commences such cure within such thirty (30) Day period and thereafter diligently prosecutes such cure to completion; provided, however, that in no event shall such cure period exceed sixty (60) Days in total. The DB Contractor hereby acknowledges and agrees that the events described in Section 17.1.1(k) through (o) are not curable. Notwithstanding the foregoing, the Mobility Authority may, without notice and without awaiting lapse of the period to cure any default, in the event of existence of a condition on or affecting the Project which the Mobility Authority believes poses an immediate and imminent danger to public health or safety, rectify the dangerous condition at the DB Contractor's cost, and so long as the Mobility Authority undertakes such action in good faith, even if under a mistaken belief in the occurrence of such default, such action shall not expose the Mobility Authority to any liability to the DB Contractor and shall not entitle the DB Contractor to any other remedy, it being acknowledged that the Mobility Authority has a paramount public interest in providing and maintaining safe public use of and access to the Project. The Mobility Authority's good faith determination of the existence of such danger shall be deemed conclusive in the absence of clear and convincing evidence to the contrary.

17.2 Remedies

17.2.1 If any breach described in Section 17.1.1 is not subject to cure or is not cured within the period (if any) specified in Section 17.1.2 the Mobility Authority may declare that an "Event of Default" has occurred. The declaration of an Event of Default shall be in writing and delivered to the DB Contractor with a copy to Surety. If an Event of Default shall occur, then the DB Contractor shall have the following obligations:

(a) The Mobility Authority may terminate this DB Agreement or a portion thereof, including the DB Contractor's rights of entry upon, possession, control and operation of the Project, in which case, the provisions of Section 16.4, Section 16.5 and Section 16.10 shall apply; and/or

(b) If requested by the Mobility Authority, the DB Contractor shall withdraw from the Final ROW and shall remove such materials, equipment, tools and instruments used by, and any debris or waste materials generated by, any member of the DB Contractor Group in the performance of the Work as the Mobility Authority may direct; and/or

(c) The DB Contractor shall deliver to the Mobility Authority possession of any or all Design Documents, Construction Documents and all other completed or partially completed drawings (including Plans, elevations, sections, details and diagrams), specifications, records, information, schedules, samples, shop drawings, electronic files and other documents and facilities related to the Final ROW that the Mobility Authority deems necessary for completion of the Work; and/or

(d) The DB Contractor shall assign to the Mobility Authority the Subcontracts requested by the Mobility Authority and the DB Contractor shall terminate, at its sole cost, those Subcontracts not assigned to the Mobility Authority; and/or

(e) The Mobility Authority may deduct from any amounts payable by the Mobility Authority to the DB Contractor such amounts payable by the DB Contractor to the

Mobility Authority, including Liquidated Damages or other damages payable to the Mobility Authority under the Contract Documents.

17.2.2 If an Event of Default shall occur, then the Mobility Authority shall have the following rights without further notice and without waiving or releasing the DB Contractor from any obligations:

(a) The Mobility Authority shall have the right, but shall not be obligated, to pay such amount and/or perform such act as may then be required.

(b) The Mobility Authority may appropriate any or all materials and equipment on the Site as may be suitable and acceptable and may, subject to the rights of Surety if the Mobility Authority elects to proceed against the Performance Bond, enter into an agreement for the completion of this DB Agreement according to the terms and provisions thereof with another contractor or the Surety, or use such other methods as may be required for the completion of this DB Agreement, including completion of the Work by the Mobility Authority.

(c) If the Mobility Authority exercises any right to perform any obligations of the DB Contractor, in the exercise of such right it may, but is not obligated to, among other things: (i) perform or attempt to perform, or cause to be performed, such work; (ii) spend such sums as the Mobility Authority deems necessary and reasonable to employ and pay such architects, engineers, consultants and contractors and obtain materials and equipment as may be required for the purpose of completing such work; (iii) execute all applications, certificates and other documents as may be required for completing the work; (iv) modify or terminate any contractual arrangements; (v) take any and all other actions which it may in its sole and absolute discretion consider necessary to complete the work; and (vi) prosecute and defend any action or proceeding incident to the Work.

(d) All costs and charges incurred by the Mobility Authority, including without limitation any re-bid costs, throw away costs for unused portions of the DB Contractor's design and increased financing costs due to delay of the Finance Closing Date, together with the cost of completing the Work, will be deducted from any monies due or that may become due to the DB Contractor. If such expense exceeds the sum which would be available from such monies, then The DB Contractor shall be liable and shall pay to the Mobility Authority the amount of such excess plus interest thereon at the lesser of (i) 12% per annum or (ii) the maximum rate allowable under applicable Law.

17.2.3 The rights and remedies of the Mobility Authority hereunder are in addition to any other rights and remedies provided by law or equity or provided under this DB Agreement, the Performance Bond, Payment Bond, or any guarantees hereunder, and the exercise or beginning of the exercise by the Mobility Authority of any one or more of any of such rights or remedies shall not preclude the simultaneous or later exercise by the Mobility Authority of any or all other such rights or remedies; provided, however, that if the Mobility Authority fails to notify the Surety of its intent to enforce the Performance Bond within 730 days after an Event of Default and the formal termination of the DB Contractor's right to complete the Work, the Performance Bond shall be deemed voided and the Surety shall be released from any further obligation thereunder.

17.2.4 The DB Contractor and Surety shall not be relieved of liability for continuing Liquidated Damages on account of a breach or default by the DB Contractor hereunder or by the Mobility Authority's declaration of an Event of Default, or by actions taken by the Mobility Authority under this Section 17.2.

17.2.5 In the event that this DB Agreement is terminated for grounds which are later determined not to justify a termination for default, such termination shall be deemed to constitute a termination for convenience pursuant to Section 16.

17.3 Failure to Comply Caused by Delay Event

Notwithstanding anything to the contrary contained herein, the Parties agree that the term "**Event of Default**" shall specifically exclude the DB Contractor's failure to meet the Project Schedule, Substantial Completion by the Completion Deadline or Final Acceptance by the Acceptance Deadline, if such failure is caused directly by an event or events beyond the DB Contractor's control, which event was not due, in whole or in part, to the breach, default, fault, act, omission, negligence, recklessness, gross negligence or willful misconduct of any member of the DB Contractor Group, and which delay could not have been avoided by due diligence and use of reasonable efforts by the DB Contractor. The foregoing circumstance is referred to herein as a "**Delay Event**," with the understanding that the term "**Delay Event**" does not apply in cases where the delay to the Critical Path is resolved by extension of the applicable completion deadline(s) under Section 14. If the DB Contractor fails to meet the Project Schedule as a result of a Delay Event, the Mobility Authority shall not be entitled to terminate this DB Agreement or exercise any of the remedies described in Section 17.2 above for such failure of the DB Contractor to perform, except as follows: (i) if the DB Contractor fails to perform or delays the performance of any Work as the result of a Delay Event, then the Mobility Authority shall have the right, but not the obligation, to cause third parties to perform such Work, and, in such event, the cost of such Work shall be deducted from the DB Price; and (ii) occurrence of a Delay Event shall not excuse the DB Contractor from its obligation to implement a Recovery Schedule or from its obligation to pay damages, including Liquidated Damages, for failure to achieve Substantial Completion by the Completion Deadline or Final Acceptance by the Acceptance Deadline. The DB Contractor shall promptly notify the Mobility Authority in writing of any occurrence of a Delay Event and of the steps that the DB Contractor intends to implement to mitigate the delays arising therefrom.

17.4 Right to Stop Work for Failure by the Mobility Authority to Make Undisputed Payment

In the event that the DB Contractor fails to receive a payment in the amount approved under Section 13.3.7 on the date specified for payment in Section 13.3.7, The DB Contractor shall promptly notify the Mobility Authority in writing. The DB Contractor shall have the right to suspend the Work if payment is not made within five (5) Business Days after delivery of the notice of nonpayment, without limitation to any other recourse of the DB Contractor. Any such suspension by the DB Contractor based on a failure of the Mobility Authority to make payment shall be considered a Mobility Authority-Caused Delay entitling the DB Contractor to a Change Order hereunder. The DB Contractor shall not have the right to terminate the DB Agreement for default in the event of the Mobility Authority's failure to make payments owing hereunder, but the DB Contractor shall have the right to declare a termination for convenience under Section 16 if

such nonpayment by the Mobility Authority continues for more than 180 days, or as otherwise provide by law.

18. DAMAGES

The DB Contractor understands and agrees that if the DB Contractor fails to complete the Work in accordance with the Contract Documents, the Mobility Authority will suffer substantial Losses. The DB Contractor agrees that it shall be liable for all such Losses. The DB Contractor and the Mobility Authority have agreed to require payment of Liquidated Damages with respect to certain types of Losses. The DB Contractor acknowledges and agrees that the Liquidated Damages provided for in the first paragraph of Section 18.1 are intended to compensate the Mobility Authority solely for the DB Contractor's failure to meet the deadlines set forth in Section 5.2 and shall not excuse the DB Contractor from liability from any other breach of requirements of the Contract Documents, including any failure of the Work to conform to applicable requirements. The DB Contractor shall not be liable for any other damages in addition to the Liquidated Damages for the DB Contractor's failure to meet the completion deadlines set forth in Section 5.2.

18.1 Liquidated Damages

18.1.1 The DB Contractor acknowledges and agrees that because of the unique nature of the Project, and the fact that inconvenience to the traveling public will be one of the significant impacts of any failure by the DB Contractor to achieve Substantial Completion by the Completion Deadline and Final Acceptance by the Acceptance Deadline, it is impracticable and extremely difficult to ascertain and determine the actual Losses which would accrue to the Mobility Authority and the public if the DB Contractor fails to achieve Substantial Completion by the Completion Deadline and Final Acceptance by the Acceptance Deadline. Therefore, the DB Contractor shall pay the Mobility Authority a liquidated amount (the "**Liquidated Damages**") as deemed compensation to the Mobility Authority for such Losses, in the amount of \$100,000 for each Day after the Completion Deadline for the items set forth in Section 20.1.1 (a) – (e) and \$25,000 for each Day after the Completion Deadline for the items set forth in Section 20.1.1(f) as its sole remedy for failure to meet the Completion Deadline (provided that the maximum aggregate amount for failure to meet all of the items set forth in Section 20.1.1(a) – (f) is \$125,000) and \$12,000 for each Day after the Acceptance Deadline as its sole remedy for failure to meet the Acceptance Deadline.

18.1.2 Separate and apart from the Liquidated Damages described in Section 18.1.1, the DB Contractor shall be liable for and pay to the Mobility Authority Liquidated Damages with respect to any failure to meet the deadlines for toll infrastructure installation and operational testing as set forth in Technical Provision 5. Pursuant to such Technical Provision 5, toll infrastructure installation for the Toll Gantries must occur at least 90 Days prior to the Substantial Completion Deadline ("**Toll Gantry Completion Deadlines**") or Liquidated Damages will accrue at a rate of \$5,000 per Day per Toll Gantry until the installation for such toll infrastructure for the Toll Gantries actually occurs. Additionally, the DB Contractor shall pay to the Mobility Authority Liquidated Damages in the amount of \$5,000 per Toll Gantry for each Day after the Operational Testing Deadline for any failure of the DB Contractor to complete the Work required for operational testing of the Toll Gantries and related toll equipment as more fully described in

Technical Provision 5. The Operational Testing Deadline is 30 Days prior to the Substantial Completion Deadline for the Toll Gantries and related toll equipment.

The Liquidated Damages pursuant to this Section 18.1.2 are meant to cover the costs to the Mobility Authority of increased oversight related to the Project and this DB Agreement and increased costs attributable to the Mobility Authority's contract with its System Integrator, including but not limited to the cost of hiring additional System Integrator work crews to complete the System Integrator contract work. As such, these Liquidated Damages will continue to accrue and be payable to the Mobility Authority by the DB Contractor after the Completion Deadline in addition to, and not in substitution for, the Liquidated Damages payable pursuant to Section 18.1.1 for failure to meet the Completion Deadline.

18.1.3 The DB Contractor shall be liable to the Mobility Authority for certain lane assessment fees as specified in detail in Technical Provision 22. The DB Contractor understands and agrees that it is the intent of the Mobility Authority to subject certain lane closures to lane assessment fees in order to minimize lane closures due to the potential harm and detriment to Project users and the potential harm and detriment to the reputation of the Mobility Authority, which are difficult to quantify and prove.

18.1.4 [RESERVED]

18.1.5 The DB Contractor understands and agrees that any Liquidated Damages payable in accordance with this Section 18.1 are in the nature of liquidated damages and not a penalty and that such sums are reasonable under the circumstances existing as of the Effective Date. The DB Contractor further acknowledges and agrees that Liquidated Damages may be owing as the result of a Delay Event, even though no Event of Default has occurred or been declared.

18.2 **Payment Terms/Offset; Reduction; Waiver**

18.2.1 Liquidated Damages shall be payable by the DB Contractor to the Mobility Authority within thirty (30) Days after the DB Contractor's receipt of an invoice therefor from the Mobility Authority. Interest on such amounts shall accrue at the lesser of (i) 12% per annum or (ii) the maximum rate allowable under applicable Law following the expiration of such thirty (30) Day period. The Mobility Authority shall have the right, in its sole discretion, to deduct any amount owed by the DB Contractor to the Mobility Authority hereunder from any amounts owed by the Mobility Authority to the DB Contractor, including any Retainage which may be payable by the Mobility Authority to the DB Contractor.

18.2.2 Permitting or requiring the DB Contractor to continue and finish the Work or any part thereof after the Completion Deadline or Acceptance Deadline shall not act as a waiver of the Mobility Authority's right to receive Liquidated Damages hereunder or any rights or remedies otherwise available to the Mobility Authority.

18.3 **Limitation of DB Contractor's Liability**

18.3.1 The DB Contractor's liability to the Mobility Authority for damages, Losses, costs and expenses of any kind resulting from or relating to this DB Agreement or performance of the Work (or failure to perform same), whether in contract, negligence or other tort, or any other theory of law, but excluding damages and Losses covered by insurance proceeds, and gross negligence,

willful misconduct, fraud or criminal conduct on the part of the DB Contractor, shall be limited to the sum of (a) all those costs reasonably incurred by the Mobility Authority or any party acting on the Mobility Authority's behalf in completing or correcting the Work or having the Work completed or corrected by another Person (provided that the DB Contractor shall be entitled to a credit against the damages otherwise payable to the Mobility Authority for amounts deducted and withheld by the Mobility Authority from the DB Price for purposes of paying such completion and correction costs), plus (b) the amount of \$40,000,000 (which sum shall specifically include and act as a limit on Liquidated Damages paid pursuant to this Section 18 and Section 19.1, any fees paid pursuant to Sections 7.4, 14.2.1.2, and 14.2.1.4, and any payments made to or for the benefit of the Indemnified Parties pursuant to Section 23) plus (c) a maximum of \$10,000,000 for any payments for lost toll revenues pursuant to Section 12.1.4; provided, however, that the DB Contractor's liability to the Mobility Authority shall in no event exceed the amount of the DB Price.

18.3.2 Except for lost toll revenues payable pursuant to Section 12.1.4 (as limited by Section 18.3.1 (c) above) and subject to subparagraphs (a) and (b) below, in no event shall the DB Contractor be liable to the Mobility Authority for any indirect, special or consequential damages (including, without limitation, loss of use, cost of capital, debt service, loss of profit on this or related contracts, administrative costs, claims of taxpayers and other indirect damage) resulting from or relating to this DB Agreement or performance of the Work (or failure to perform same), and Mobility Authority hereby releases the DB Contractor from such liability.

The foregoing waiver of consequential damages shall apply to limit liability under actions brought under any theory of law, including actions in tort (including negligence) as well as in contract. The foregoing release of liability by the Mobility Authority shall extend to all members of the DB Contractor Group.

The foregoing waiver of consequential damages shall not exclude or affect:

(a) Any liability for gross negligence, fraud, intentional misconduct, or criminal acts by the DB Contractor or liability for Liquidated Damages under this DB Agreement; and

(b) Any liability for any type of damage or loss, to the extent such loss or damage is covered by insurance the DB Contractor carries under project specific policies applicable to the Project and the Work.

19. LABOR AND EMPLOYMENT REQUIREMENTS

19.1 Key Personnel; Qualifications of Employees

19.1.1 The Contract Documents identify certain job categories of Key Personnel for the Project. The DB Contractor shall not change, or permit any change in, any Key Personnel without the prior written consent of the Mobility Authority in accordance with Technical Provision 1.

19.1.2 All individuals performing Work shall have the skill and experience and any licenses required to perform the Work assigned to them. If the Mobility Authority determines, in its sole discretion, that any Person employed by the DB Contractor or any Subcontractor is not performing the Work in a proper, desirable and skillful manner or is detrimental to the progress of

the Work and/or the Project, then, at the written request of the Mobility Authority, the DB Contractor shall remove such Person from the Project and such Person shall not be reemployed on the Project without the prior written approval of the Mobility Authority. If such Person is not removed or if the DB Contractor fails to ensure that skilled and experienced personnel are furnished for the proper performance of the Work, then the Mobility Authority may suspend the affected portion of the Work by delivery of written notice of such suspension to the DB Contractor. Such suspension shall in no way relieve the DB Contractor of any obligation contained in the Contract Documents or entitle the DB Contractor to a Claim or Change Order. Once compliance is achieved, the DB Contractor shall be entitled to and shall promptly resume the Work. During the period of any such suspension, the DB Contractor shall not be entitled to the payment of any portion of the DB Price or any other payment hereunder.

19.1.3 The DB Contractor shall designate in writing who shall have onsite field and office authority to represent and act for the DB Contractor. An appropriately designated representative shall be present at the jobsite at all times while Work is actually in progress. While any night work or shift work is to be performed by the DB Contractor, a superintendent shall be at the jobsite at all times. The DB Contractor shall provide mobile phone numbers for all Key Personnel. The Mobility Authority requires the ability to contact these key individuals 24 hours per Day, seven Days per week.

19.1.4 The DB Contractor acknowledges and agrees that the award of this DB Agreement by the Mobility Authority to the DB Contractor was based, in large part, on the qualifications and experience of the personnel listed in the Proposal and the DB Contractor's commitment that such individuals would be available to undertake and perform the Work. The DB Contractor represents, warrants and covenants that such individuals are available for and will fulfill the roles identified for them in the Proposal in connection with the Work. Unless otherwise agreed to by the Mobility Authority in writing, individuals filling Key Personnel roles shall devote 100% of their work time, as required herein, to the prosecution and performance of the Work to the extent necessary to satisfactorily and timely complete their designated duties under the Contract Documents. By way of illustration and example, the Design Manager would be expected to devote full time to the Project until Final Design Plans are accepted by the Mobility Authority, but, thereafter, could reduce his or her commitment to such work time as is necessary to aid the Construction Manager and the DB Contractor Project Manager in completing construction of the Project.

19.1.5 If an individual filling one or more Category A Personnel roles is not available for the Work and does not maintain active involvement in the prosecution and performance of the Work and such individual has not been replaced by an individual approved by the Mobility Authority, the DB Contractor acknowledges that the Mobility Authority, the Work and the Project will suffer significant and substantial additional Losses due to the unavailability of an approved individual to fill a Category A Personnel role and that it is impracticable and extremely difficult to ascertain and determine the actual Losses which would accrue to the Mobility Authority in such event. Therefore, for each day that a Category A Personnel role is not filled by an approved individual, the Mobility Authority will apply the provisions of Exhibit Q to this DB Agreement.

19.1.6 The DB Contractor understands and agrees that any damages payable in accordance with this Section 19.1 are in the nature of Liquidated Damages and not a penalty and that such sums are reasonable under the circumstances existing as of the Effective Date. The Mobility Authority shall have the right to deduct any amount owed by the DB Contractor to the Mobility

Authority hereunder from any amounts owed by the Mobility Authority to the DB Contractor, including any Retainage which may be payable by the Mobility Authority to the DB Contractor. Notwithstanding the foregoing, the DB Contractor shall not be liable for Liquidated Damages under this Section 19.1 if (i) the DB Contractor removes or replaces such personnel at the direction of the Mobility Authority; (ii) such individual is unavailable due to death, disability, retirement, injury or no longer being employed by the applicable member of the DB Contractor Group (provided that moving to an affiliated company shall not be considered grounds for avoiding Liquidated Damages), or (iii) such individual is unavailable due to the Mobility Authority's failure to issue NTP2 within 210 Days of the Proposal Date; provided, however, in each such case, DB Contractor shall promptly propose to the Mobility Authority a replacement for such personnel, which individual shall be subject to the Mobility Authority's review and written consent. In the event NTP2 has not been issued within 210 Days after the Proposal Date, the DB Contractor shall have thirty (30) Days after issuance of NTP2 to identify any change in Category A Personnel without incurring any Liquidated Damages, provided that such new Category A Personnel must be approved by the Mobility Authority and meet the requirements of Section 19.1.2.

19.1.7 The Mobility Authority may waive Liquidated Damages pursuant to this Section 19.1 in its sole discretion.

19.1.8 The DB Contractor shall notify the Mobility Authority at least twenty (20) Business Days in advance of a proposed replacement of any Key Personnel, and submit the name and qualifications summary of the proposed replacement to the Mobility Authority. The Mobility Authority will review the qualifications and may interview the proposed replacement. The Mobility Authority reserves the right to approve or reject, without cause, any proposed replacement, and will provide such written approval or rejection within twenty (20) Business Days after receipt of the qualifications documentation. If no response is provided within twenty (20) Business Days the proposed replacement shall be considered rejected.

19.2 Responsibility for Employees and Subcontractors

The DB Contractor shall supervise and be responsible for the actions, omissions, negligence, willful misconduct, or breach of applicable Law or contract by any member of the DB Contractor Group, as though all such Persons were directly employed by the DB Contractor.

19.3 Subcontracts

19.3.1 Each instrument evidencing any agreement of the DB Contractor with any Subcontractor shall provide, in terms and in form and substance satisfactory to the Mobility Authority that: (a) the rights of the DB Contractor under such instrument are assigned to the Mobility Authority contingent only upon delivery of written request from the Mobility Authority or its successor or assign following default by the DB Contractor or termination or expiration of this DB Agreement; and (b) all warranties (express and implied) of such Subcontract shall inure to the benefit of the Mobility Authority.

19.3.2 The DB Contractor shall provide the Mobility Authority with a list of all Subcontracts from time to time upon request, shall allow the Mobility Authority access to all Subcontracts and records regarding Subcontracts and shall deliver to the Mobility Authority, within ten Days after execution, copies of all Major Subcontracts and, within ten Days after receipt

of a request from the Mobility Authority, copies of all other agreements or documents as may be requested.

19.3.3 The appointment of Subcontractors by the DB Contractor will not relieve the DB Contractor of its responsibility hereunder or for the quality of the Work or materials provided by it. The DB Contractor will at all times be held fully responsible to the Mobility Authority for the actions, omissions, negligence, willful misconduct, or breach of applicable Law or contract by its Subcontractors and persons employed by them and no Subcontract entered into by the DB Contractor will impose any obligation or liability upon the Mobility Authority to any such Subcontractor or any of its employees. Nothing in this DB Agreement will create any contractual relationship between the Mobility Authority and any Subcontractor of the DB Contractor.

19.3.4 The following requirements shall apply to Subcontracts:

(a) The DB Contractor shall, within 30 days of execution of this DB Agreement, submit to the Mobility Authority for its review a procedure for the conduct of the selection and approval process applicable to Major Subcontracts. Such procedure may provide that award of any Major Subcontract will go to the lowest responsive bid by a responsible bidder, to the bidder providing the best value proposal or through a negotiation process. The DB Contractor may use procedures set forth in the TxDOT Specifications or may submit alternative competitive low bid procedures to the Mobility Authority for review, may submit a competitive best value selection procedure to the Mobility Authority for review, or may show why a negotiation process will provide the best value. The DB Contractor shall not enter into any Major Subcontracts except in accordance with the foregoing procedure. The foregoing procedure is not required of Major Participants that have been previously identified in the DB Contractor's Proposal. Once the DB Contractor has entered into any Major Subcontract, the DB Contractor shall not have the right to make any substitution of such Subcontractor except with the Mobility Authority's prior written approval.

(b) As soon as a potential Subcontractor has been identified by the DB Contractor, but in no event later than five Days after Subcontract execution, the DB Contractor shall notify the Mobility Authority in writing of the name, address, phone number and contact name of such Subcontractor that has not been previously identified as a Major Subcontractor in the DB Contractor's Proposal.

(c) Each Subcontract shall include terms and conditions sufficient to ensure compliance by the Subcontractor with the requirements of the Contract Documents, and shall include those terms that are specifically required by the Contract Documents to be included therein. All Subcontracts, including Subcontracts with Suppliers, shall incorporate terms substantially similar to those contained in this DB Agreement, specifically including an agreement by the Subcontractor or Supplier to participate in any dispute review proceeding pursuant to Section 25, if such participation is requested by either the Mobility Authority or the DB Contractor.

19.3.5 Each Subcontract shall:

(a) Set forth a standard of professional responsibility or a standard for commercial practice equal to prudent industry standards for work of similar scope and scale and shall set forth effective procedures for claims and change orders.

(b) Require the Subcontractor to carry out its scope of work in accordance with this DB Agreement, the Governmental Approvals and applicable Law, including the applicable requirements of the DBE Performance Plan.

(c) Set forth warranties, guaranties and liability provisions of the contracting party in accordance with good commercial practice for work of similar scope and scale.

(d) Be fully assignable without cost to the Mobility Authority or TxDOT, such assignability to include the benefit of all Subcontractor warranties, indemnities, guaranties and professional responsibility and include express requirements that: (i) it will maintain usual and customary books and records for the type and scope of operations of business in which it is engaged (e.g., constructor, equipment supplier, designer, service provider); (ii) permit audit thereof by the DB Contractor, and provide progress reports to the DB Contractor appropriate for the type of work it is performing sufficient to enable the DB Contractor to provide the reports it is required to furnish the Mobility Authority or TxDOT under this DB Agreement; and (iii) allow the Mobility Authority or TxDOT to assume the benefit of the DB Contractor's rights with liability only for those remaining obligations of the DB Contractor accruing after the date of assumption by the Mobility Authority or TxDOT.

(e) Not be assignable by the Subcontractor without the DB Contractor's prior written consent.

(f) With respect to any Subcontract which, when aggregated with all Subcontracts between the DB Contractor and such Subcontractor for the same Fiscal Year, is in excess of \$250,000: (i) be terminable by the Subcontractor only for cause; and (ii) include an indemnity from the Subcontractor in favor of the DB Contractor and the Indemnified Parties against any and all Losses arising out of, related to or associated with, the actions, omissions, negligence, willful misconduct, or breach of applicable Law or contract by the Subcontractor or any of its officers, employees, agents or representatives.

(g) Expressly require the Subcontractor to participate in meetings between the DB Contractor and the Mobility Authority, upon the Mobility Authority's request, concerning matters pertaining to such Subcontract or its work, provided that all direction to such Subcontractor shall be provided by the DB Contractor, and provided further that nothing in this *clause (g)* shall limit the authority of the Mobility Authority to give such direction or take such action which, in its opinion, is necessary to remove an immediate and present threat to the safety of life or property.

(h) Expressly provide that all Liens, claims and charges of the Subcontractor and its subcontractors at any time shall not attach to any interest of the Mobility Authority in the Project or the Final ROW.

(i) Be consistent in all other respects with the terms and conditions of this DB Agreement to the extent such terms and conditions are applicable to the scope of work of such Subcontractors, and include all provisions required by the DB Agreement.

19.3.6 The DB Contractor shall not amend any Subcontract with respect to any of the foregoing matters without the prior written consent of the Mobility Authority.

19.3.7 The DB Contractor shall not enter into any Subcontracts with any Person then debarred or suspended from submitting bids by any agency of the State or the federal government.

19.3.8 The DB Contractor shall include a provision in each Subcontract requiring the Subcontractor to maintain all licenses required by applicable Laws.

19.3.9 All Subcontracts with Affiliates shall be arm's-length, and on terms no less favorable to the DB Contractor than to non-Affiliates of the Subcontractor.

19.3.10 In no event shall the DB Contractor enter into Subcontracts for more than 70% of the Work, either in terms of the DB Price or actual Work.

20. COMPLETION AND ACCEPTANCE

20.1 Substantial Completion

20.1.1 The DB Contractor shall provide written notice to the Mobility Authority no later than ninety (90) Days prior to the date when all of the following will occur:

(a) The DB Contractor has completed the Work, except for Punch List items, the portion of the Work described in *subsection (f)*, and final cleanup and other items included in the requirements for Final Acceptance of the Project;

(b) The DB Contractor has ensured that all Work relating to the Project, except for the portion of the Work described in *subsection (f)*, has been performed in accordance with the requirements of the Contract Documents, the Governmental Approvals and applicable Law;

(c) The Project may be operated without damage to the Project, the Final ROW or any other property adjacent or nearby the Final ROW, and without injury to any Person;

(d) The Project (i) can be safely opened to public use, (ii) is fully signed and striped, and (iii) has all safety appurtenances installed;

(e) All remaining Punch List work for the Project can be completed with no impact to traffic. If any lane closures are required to complete the Punch List items, the DB Contractor shall be only entitled to close lanes upon approval by the Mobility Authority; and

(f) The DB Contractor has completed the work related to shared use paths, sidewalks and ADA improvements as described in *Exhibit B* and ensured that such work has been performed in accordance with the requirements of the Contract Documents, the Governmental Approvals and applicable Law.

20.1.2 Substantial Completion of the Project shall be deemed to have occurred when:

(a) The items set forth in *Section 20.1.1 (a) – (f)* have occurred;

(b) The DB Contractor has corrected any defects and deficiencies in the Work relating to the Project to the satisfaction of the Mobility Authority, and the Mobility Authority has

notified the DB Contractor in writing of its acceptance, or waiver pending Final Acceptance, of such corrections and the concurrence that Substantial Completion of the Project has occurred;

(c) The DB Contractor has received all applicable Governmental Approvals required for the Project and to be obtained by the DB Contractor pursuant to this DB Agreement;

(d) All Adjustments have been accepted by the applicable Utility Owners;

(e) A Punch List to be performed prior to Final Acceptance of the Project has been mutually agreed to by the Mobility Authority and the DB Contractor;

(f) All equipment and other Work to be provided by the DB Contractor with respect to toll collection systems has been provided, completed, tested, and is fully operational; and

(g) The Mobility Authority has issued a certificate of Substantial Completion to the DB Contractor acknowledging the satisfaction of the conditions set forth in (a) – (f) above. The Mobility Authority agrees to issue such certificate when such conditions have been satisfied.

20.1.3 Notification of Substantial Completion

(a) The DB Contractor shall provide the Mobility Authority with not less than 20 days' prior written notification of the date the DB Contractor determines it will achieve Substantial Completion. During such 20-day period, the DB Contractor and the Mobility Authority shall meet and confer and exchange information on a regular cooperative basis with the goal being the Mobility Authority's orderly, timely inspection and review of the Project and the Final Design Documents and Construction Documents, and the Mobility Authority's issuance of a certificate of Substantial Completion.

(b) During such 20-day period, the Mobility Authority shall conduct an inspection of the Project and its components, a review of the Final Design Documents and Construction Documents and such other investigation as may be necessary to evaluate whether Substantial Completion is achieved.

(c) The DB Contractor shall provide the Mobility Authority a second written notification when the DB Contractor determines it has achieved Substantial Completion. Within five days after expiration of the 20-day period and the Mobility Authority's receipt of the second notification, the Mobility Authority shall either: (a) issue the Certificate of Substantial Completion (dated as of the date of the DB Contractor's second notification) or (b) notify the DB Contractor in writing setting forth, as applicable, why the Project has not reached Substantial Completion. If the Mobility Authority and the DB Contractor cannot agree as to the date of Substantial Completion, such dispute shall be resolved according to the dispute resolution procedures set forth in this DB Agreement.

20.2 Final Acceptance

20.2.1 Promptly after Substantial Completion of all or an agreed specified portion of the Project, the DB Contractor shall perform all Work, if any, which was deferred in connection with the Substantial Completion, and shall satisfy all of its other obligations under the Contract

Documents, the Governmental Approvals and applicable Law, including ensuring that all equipment, materials, facilities, improvements, structures and components have been properly adjusted and tested. Final Acceptance of the Project shall be deemed to have occurred when all of the following have occurred:

(a) All requirements for Substantial Completion of the Project shall have been fully satisfied, as determined by the Mobility Authority;

(b) The Mobility Authority shall have received all Design Documents, Final Construction Plans, surveys, maintenance manuals, electronic files, test data and other deliverables relating to the Project required under the Contract Documents;

(c) All special tools, equipment, furnishings and supplies purchased and/or used by the DB Contractor solely for the Project as provided in the Contract Documents shall have been delivered to the Mobility Authority and all replacement spare parts shall have been purchased and delivered to the Mobility Authority, free and clear of Liens;

(d) All personnel, supplies, equipment, waste materials, rubbish and temporary facilities of each member of the DB Contractor Group shall have been removed from the Final ROW, the DB Contractor shall restore and repair all damage or injury arising from such removal to the satisfaction of the Mobility Authority, and the Final ROW shall be in good working order and condition;

(e) The DB Contractor shall have delivered to the Mobility Authority a certification representing that there are no outstanding claims of the DB Contractor or claims, Liens or stop notices of any first tier Subcontractor, laborer, Utility Owner or railroads with respect to the Work for the Project, other than any previously submitted unresolved claims of the DB Contractor on behalf of itself or on behalf of a first tier Subcontractor, laborer, Utility Owner or railroad. For purposes of such certificate, the term "claim" shall include all matters or facts which may give rise to a claim;

(f) The Punch List items for the Project shall have been completed to the satisfaction of the Mobility Authority, all of the DB Contractor's other obligations under the Contract Documents, the Governmental Approvals and applicable Law, other than obligations which by their nature are required to be performed after Final Acceptance of the Project, shall have been satisfied in full or waived;

(g) The DB Contractor shall have finalized and closed out all Governmental Approvals; and

(h) The DB Contractor shall have requested and the Mobility Authority shall have issued a certificate of Final Acceptance to the DB Contractor acknowledging the satisfaction of the conditions set forth in clauses (a)-(g) above. The Mobility Authority agrees to issue such certificate when such conditions have been satisfied.

20.2.2 The DB Contractor shall provide the Mobility Authority with written notification when the DB Contractor determines it has achieved Final Acceptance. During the 15-day period following receipt of such notification, the DB Contractor and the Mobility Authority shall meet and confer and exchange information on a regular cooperative basis with the goal being the orderly,

timely inspection and review of the Project and the Final As-Built Plans, and the Mobility Authority's issuance of a certificate of Final Acceptance for the Project.

20.2.3 During such 15-day period, the Mobility Authority shall conduct an inspection of the Punch List items, a review of the Final As-Built Plans and such other investigation as may be necessary to evaluate whether the conditions to Final Acceptance are satisfied.

20.2.4 Within five days after expiration of such 15-day period, the Mobility Authority shall either: (a) issue a Certificate of Final Acceptance for the Project or (b) notify the DB Contractor in writing setting forth, as applicable, why Final Acceptance has not been achieved. If the Mobility Authority and the DB Contractor cannot agree as to the date of Final Acceptance, such dispute shall be resolved according to the dispute resolution procedures set forth in this DB Agreement.

20.2.5 The occurrence of Final Acceptance of the Project shall not relieve the DB Contractor of any of its continuing obligations under the Contract Documents, including Warranty obligations, or constitute any assumption of liability by the Mobility Authority.

20.3 Assignment of Causes of Action

The DB Contractor shall assign to the Mobility Authority all right, title and interest in and to all claims and causes of action it may have under Section 4 of the Clayton Act (15 U.S.C. Sec. 15), arising from purchases of goods, services or materials pursuant to the Contract Documents or any Subcontract. This assignment shall be made and become effective at the time the Mobility Authority tenders Final Payment to the DB Contractor, without further acknowledgment by the Parties.

21. [RESERVED]

22. REPRESENTATIONS AND WARRANTIES

22.1 Mobility Authority Representations and Warranties

The Mobility Authority represents and warrants to the DB Contractor as follows:

(a) The Mobility Authority is duly organized and existing regional mobility authority under Chapter 370 of the Act, and has full power, right and authority to execute, deliver and perform its obligations under, in accordance with and subject to the terms and conditions of this DB Agreement and other Contract Documents to which it is a Party.

(b) Each Person executing this DB Agreement or any other Contract Document on behalf of the Mobility Authority to which the Mobility Authority is a Party has been or at such time will be duly authorized to execute each such document on behalf of the Mobility Authority.

(c) Neither the execution and delivery by the Mobility Authority of this DB Agreement and the other Contract Documents, nor the consummation of the transactions contemplated hereby or thereby, is in conflict with or will result in a default under or violation of any other agreements or instruments to which the Mobility Authority is a Party or by which it is bound.

(d) There is no action, suit, proceeding, or litigation pending and served on the Mobility Authority which challenges the Mobility Authority's authority to execute, deliver or perform, or the validity or enforceability of, this DB Agreement and the other Contract Documents to which the Mobility Authority is a Party, or which challenges the authority of the officials executing this DB Agreement or the other Contract Documents.

(e) EXCEPT AS OTHERWISE EXPRESSLY PROVIDED HEREIN, THE MOBILITY AUTHORITY EXPRESSLY DISCLAIMS ANY REPRESENTATIONS OR WARRANTIES OF ANY KIND OR NATURE, EXPRESS OR IMPLIED, AS TO THE CONDITION OR QUALITY OF THE SITE OR THE PROSPECTS (FINANCIAL AND OTHERWISE), RISKS AND OTHER INCIDENTS OF THE SITE, THE WORK AND THE PROJECT AND THE MOBILITY AUTHORITY SPECIFICALLY DISCLAIMS ANY REPRESENTATION OR WARRANTY OF MERCHANTABILITY, USAGE, SUITABILITY OR FITNESS FOR ANY PARTICULAR PURPOSE WITH RESPECT TO THE SITE, THE WORK AND THE PROJECT, OR ANY PART THEREOF, OR COMPLIANCE WITH APPLICABLE LAWS OR GOVERNMENTAL APPROVALS. WITHOUT LIMITING THE GENERALITY OF THE FOREGOING, EXCEPT AS OTHERWISE EXPRESSLY PROVIDED HEREIN, THE MOBILITY AUTHORITY EXPRESSLY DISCLAIMS ANY REPRESENTATION OR WARRANTY OF ANY KIND REGARDING THE CONDITION OF THE SITE, OR THE SUITABILITY THEREOF IN CONNECTION WITH THE WORK AND THE PROJECT AND NO SCHEDULE OR EXHIBIT TO THIS DB AGREEMENT, NOR ANY OTHER MATERIAL OR INFORMATION PROVIDED BY OR COMMUNICATIONS MADE BY THE MOBILITY AUTHORITY, SHALL CAUSE OR CREATE ANY WARRANTY, EXPRESS OR IMPLIED, AS TO THE CONDITION OR QUALITY OF THE FINAL ROW OR THE ADDITIONAL PROPERTIES.

22.2 DB Contractor Representations, Warranties, and Covenants

The DB Contractor represents, warrants and covenants to the Mobility Authority as follows:

(a) The DB Contractor has and throughout the term of this DB Agreement shall maintain all required authority, license status, professional ability, skills and capacity to perform the DB Contractor's obligations hereunder and shall perform them in accordance with the requirements contained in the Contract Documents.

(b) Except with respect to non-material deviations as permitted herein, the design for the Project can and shall be based on the Schematic Plan, and the Project can and shall be built in conformity with the Contract Documents, all applicable Laws and Governmental Approvals.

(c) The DB Contractor has evaluated the feasibility of performing the Work within the deadlines specified herein and for the DB Price, without relying on any information or item other than that which is expressly set forth in the Contract Documents, and has reasonable grounds for believing and does believe that such performance (including achievement of Substantial Completion of the Project by the Completion Deadline and Final Acceptance by the Acceptance Deadline, for the DB Price) is feasible and practicable.

(d) The DB Contractor has, prior to submitting its Proposal, in accordance with prudent and generally accepted engineering practices, reviewed the exploratory geotechnical information, inspected and, to the extent access was made available by the Mobility Authority, examined the Site and surrounding locations and undertaken other activities sufficient to familiarize itself with surface conditions and subsurface conditions discernible from the surface affecting the Project to the extent the DB Contractor deems necessary or advisable for performing its obligations under the Contract Documents, and as a result of such review, inspection, examination and other activities the DB Contractor is familiar with and accepts the physical requirements of the Work. The DB Contractor acknowledges and agrees that it has been afforded the opportunity to review information and documents and, to the extent access was made available by the Mobility Authority, to conduct inspections and tests of the Site and surrounding locations as described above. Before commencing any work on a particular portion or aspect of the Project, the DB Contractor shall verify all governing dimensions of the Site and shall examine all adjoining work (including Adjacent Work) which may have an impact on such work. The DB Contractor shall ensure that the Design Documents and Construction Documents accurately depict all governing and adjoining dimensions.

(e) The DB Contractor acknowledges and agrees that it has familiarized itself with the requirements of any and all applicable Laws and the conditions and schedules contained in all Governmental Approvals prior to entering into this DB Agreement. The DB Contractor shall comply with the foregoing at its sole cost and expense and without any increase in the DB Price or extension of any Completion Deadline or any Acceptance Deadline on account of such compliance, regardless of whether such compliance would require additional time for performance or additional labor, equipment and/or materials not expressly provided for in the Contract Documents. The DB Contractor has no reason to believe that any Governmental Approval required to be obtained by the DB Contractor will not be granted in due course and, thereafter, remain in effect in order to enable the Work to proceed in accordance with the Contract Documents. If any Governmental Approval required to be obtained by the DB Contractor must formally be issued in the name of the Mobility Authority, the DB Contractor shall undertake all efforts to obtain such approvals, subject to the Mobility Authority's reasonable cooperation and assistance with the DB Contractor, including preparation and delivery of appropriate applications and other documentation in a form approved by the Mobility Authority.

(f) The DB Contractor shall comply with all requirements of the approved DQMP and the CQMP and all requirements of the Mobility Authority's QAP.

(g) All design and engineering work furnished by the DB Contractor shall be performed by or under the supervision of Persons licensed to practice architecture, engineering or surveying, as applicable, in the State, by personnel who are skilled, experienced and competent in their respective trades or professions, who are professionally qualified to perform the Work in accordance with the Contract Documents, the Governmental Approvals and applicable Law and who shall assume professional responsibility for the accuracy and completeness of the Design Documents and Construction Documents prepared or reviewed by them.

(h) The DB Contractor shall, at all times, schedule and direct its activities to provide an orderly progression of the Work to achieve completion within the specified time for completion and in accordance with the Project Schedule, including furnishing such employees, materials, facilities and equipment and working such hours, including continuous or extra shifts,

overtime operations, Sundays and holidays as may be necessary to achieve such goal, all at the DB Contractor's own expense except as otherwise specifically provided in Section 14.

(i) At all times, including during the course of, and notwithstanding the existence of, any dispute, the DB Contractor shall perform as directed by the Mobility Authority, in a diligent manner and without delay, shall abide by the Mobility Authority's decision or order, and shall comply with all applicable provisions of the Contract Documents.

(j) The DB Contractor is an unincorporated Joint Venture, comprised of (1) Archer Western Construction, LLC, a limited liability company, duly formed, validly existing and in good standing under the Laws of the State of Illinois, and (ii) Sundt Construction, Inc., a corporation, duly formed, validly existing and in good standing under the Laws of the State of Arizona. The DB Contractor and each of its joint venturers are duly qualified to do business and are in good standing under the Laws of the State of Texas and will remain in good standing throughout the term of this DB Agreement and for as long thereafter as any obligations remain outstanding under the Contract Documents.

(k) The DB Contractor has the requisite power and all required licenses to carry on its present and proposed activities, and has full power, right and authority to execute and deliver this DB Agreement and to perform each and all of the obligations of the DB Contractor provided for herein.

(l) The DB Contractor has taken or caused to be taken all requisite action to authorize the execution and delivery of, and the performance of its obligations under, this DB Agreement and the other Contract Documents.

(m) Each individual executing this DB Agreement or any other Contract Documents on behalf of the DB Contractor or any of its members has been or will at such time be duly authorized to execute each such document on behalf of such Person.

(n) Neither the execution and delivery of this DB Agreement and the other Contract Documents by the DB Contractor, nor the compliance by the DB Contractor with any provision hereof or thereof, nor the consummation of the transactions contemplated hereby or thereby by the DB Contractor shall violate or conflict with, or result in a breach of, any provisions of the organizational documents of the DB Contractor or its members, any other agreements and instruments to which the DB Contractor or its members is a party or by which any such Person is bound, or any Law applicable to the DB Contractor or its members.

(o) No consent or approval of, filing with or notice to any Person is required to be obtained or made by the DB Contractor or its members in connection with the DB Contractor's execution, delivery and performance of this DB Agreement and the other Contract Documents, or the consummation of the transactions contemplated hereby or thereby, which, if not obtained or made, would prevent the DB Contractor from performing its obligations hereunder or thereunder.

(p) There is no action, suit, proceeding, or litigation pending and served on the DB Contractor or any of its members which challenges the DB Contractor's authority to execute, deliver or perform, or the validity or enforceability of, this DB Agreement and the other Contract Documents, or which challenges the authority of any individual executing this DB Agreement on behalf of the DB Contractor; and the DB Contractor has disclosed to the Mobility Authority any

pending and unserved action, suit, proceeding, investigation or litigation with respect to such matters of which the DB Contractor has actual knowledge.

(q) The DB Contractor is in compliance with all Laws applicable to the DB Contractor or its activities in connection with this DB Agreement and the other Contract Documents.

(r) The DB Contractor owns, or will own, and has, or will have, good and marketable title to all materials, equipment, tools and supplies furnished, or to be furnished, by it and its Subcontractors that become part of the Project or are purchased for the operation, maintenance or repair thereof, free and clear of all Liens.

(s) The DB Contractor has delivered to the Mobility Authority true and complete copies of the financial information required under Section 26.3 ("**Audited Financial Statements**"). The Audited Financial Statements have been prepared in conformity with generally accepted accounting principles, consistently applied, and present fairly the financial position and results of the operations and cash flows of the applicable entity(ies) at the dates and for the periods stated.

(t) The information, statements, certifications and materials set forth in the Proposal are true, complete and accurate in all material respects and are not misleading in any material respect.

(u) In entering into this DB Agreement, the DB Contractor has not relied on any representation, warranty, promise or statement, express or implied, of the Mobility Authority, or anyone acting for or on behalf of the Mobility Authority, other than as expressly set forth in this DB Agreement, and that all matters concerning the Site, the Work and the Project have been or shall be independently verified by the DB Contractor, and that the DB Contractor has executed this DB Agreement and has agreed to undertake and complete the Work based solely upon the DB Contractor's own prior investigations and examinations, or the DB Contractor's election not to do so.

23. INDEMNIFICATION; RELEASES

23.1 Indemnification by the DB Contractor

23.1.1 SUBJECT TO SECTION 18.3 HEREOF, THE DB CONTRACTOR SHALL RELEASE, DEFEND, INDEMNIFY AND HOLD EACH OF THE INDEMNIFIED PARTIES HARMLESS FROM AND AGAINST ANY AND ALL LOSSES ARISING OUT OF, RELATING TO OR RESULTING FROM:

(a) THE BREACH OR ALLEGED BREACH OF THIS DB AGREEMENT OR ANY OTHER CONTRACT DOCUMENTS BY THE DB CONTRACTOR.

(b) THE FAILURE OR ALLEGED FAILURE BY ANY MEMBER OF THE DB CONTRACTOR GROUP TO COMPLY WITH ANY APPLICABLE LAWS OR THE GOVERNMENTAL APPROVALS.

(c) ANY ALLEGED PATENT OR COPYRIGHT INFRINGEMENT OR OTHER ALLEGEDLY IMPROPER APPROPRIATION OR USE OF TRADE SECRETS, PATENTS, PROPRIETARY INFORMATION, KNOW-HOW, COPYRIGHT RIGHTS OR INVENTIONS IN PERFORMANCE OF THE WORK, OR ARISING OUT OF ANY USE IN CONNECTION WITH THE PROJECT OF METHODS, PROCESSES, DESIGNS, INFORMATION, OR OTHER ITEMS FURNISHED OR COMMUNICATED TO THE MOBILITY AUTHORITY OR ANOTHER INDEMNIFIED PARTY PURSUANT TO THE CONTRACT DOCUMENTS; PROVIDED THAT THIS INDEMNITY SHALL NOT APPLY TO ANY INFRINGEMENT RESULTING FROM THE MOBILITY AUTHORITY'S FAILURE TO COMPLY WITH SPECIFIC WRITTEN INSTRUCTIONS REGARDING USE PROVIDED TO THE MOBILITY AUTHORITY BY THE DB CONTRACTOR.

(d) THE ACTS, OMISSIONS, NEGLIGENCE, RECKLESSNESS, WILLFUL MISCONDUCT, BREACH OF CONTRACT OR LAW BY ANY MEMBER OF THE DB CONTRACTOR GROUP.

(e) ANY AND ALL CLAIMS BY ANY GOVERNMENTAL ENTITY CLAIMING TAXES BASED ON GROSS RECEIPTS, PURCHASES OR SALES, THE USE OF ANY PROPERTY OR INCOME OF ANY MEMBER OF THE DB CONTRACTOR GROUP WITH RESPECT TO ANY PAYMENT FOR THE WORK MADE TO OR EARNED BY THE DB CONTRACTOR OR ITS SUBCONTRACTORS OR ANY OF THEIR RESPECTIVE AGENTS, OFFICERS OR EMPLOYEES UNDER THE CONTRACT DOCUMENTS.

(f) ANY AND ALL STOP NOTICES AND/OR LIENS FILED IN CONNECTION WITH THE WORK, INCLUDING ALL EXPENSES AND ATTORNEYS' FEES AND COSTS INCURRED IN DISCHARGING ANY STOP NOTICE OR LIEN.

(g) ANY (I) RELEASE(S) OF HAZARDOUS MATERIALS ATTRIBUTABLE TO THE ACTS, OMISSIONS, NEGLIGENCE, WILLFUL MISCONDUCT, RECKLESSNESS OR BREACH OF CONTRACT OR LAW BY ANY MEMBER OF THE DB CONTRACTOR GROUP; OR (II) THE RELEASE OF ANY HAZARDOUS MATERIALS CAUSED TO BE PRESENT ON THE FINAL ROW OR ELSEWHERE BY ANY MEMBER OF THE DB CONTRACTOR GROUP REGARDLESS OF WHETHER THOSE ARE THE PERSONS WHO ACTUALLY CAUSED THE RELEASE AND REGARDLESS OF THE CAUSE FOR THE RELEASE.

(h) ANY INCONVENIENCE, DISRUPTION, DELAY OR LOSS CAUSED BY INTERFERENCE BY ANY MEMBER OF THE DB CONTRACTOR GROUP WITH OR HINDERING THE PROGRESS OR COMPLETION OF WORK BEING PERFORMED BY OTHER CONTRACTORS RELATING TO THE PROJECT, ANY OTHER PROJECT (INCLUDING ADJACENT WORK), OR FAILURE OF ANY MEMBER OF THE DB CONTRACTOR GROUP TO COOPERATE REASONABLY WITH OTHER CONTRACTORS IN ACCORDANCE WITH THE REQUIREMENTS OF THE CONTRACT DOCUMENTS.

(i) ANY CLAIM, DEMAND, SUIT, PROCEEDING, INVESTIGATION OR CAUSE OF ACTION BROUGHT AGAINST THE MOBILITY AUTHORITY IN CONNECTION WITH ALLEGED WRONGFUL ACTS OR OMISSIONS RELATED TO THE

DESIGN AND/OR CONSTRUCTION OF THE PROJECT OR OTHER WORK, INCLUDING WITH RESPECT TO CONSTRUCTION ACCIDENTS.

(j) ANY CLAIM, DEMAND, SUIT, PROCEEDING, INVESTIGATION OR CAUSE OF ACTION BROUGHT AGAINST THE MOBILITY AUTHORITY IN CONNECTION WITH (I) THE DB CONTRACTOR'S PERFORMANCE OF, OR FAILURE TO PERFORM ITS OBLIGATIONS UNDER, ANY UTILITY ADJUSTMENT AGREEMENT, (II) ANY CLAIM FOR REIMBURSEMENT FOR THE COST OF PERFORMING UTILITY ADJUSTMENT WORK MADE BY A UTILITY OWNER AGAINST THE MOBILITY AUTHORITY, OR (III) ANY DISPUTE AS TO WHETHER WORK RELATING TO A UTILITY ADJUSTMENT CONSTITUTES A BETTERMENT.

23.1.2 SUBJECT TO SECTION 23.2, THE DB CONTRACTOR SHALL RELEASE, DEFEND, INDEMNIFY AND HOLD EACH OF THE INDEMNIFIED PARTIES HARMLESS FROM AND AGAINST ANY AND ALL LOSSES RESULTING FROM ERRORS, OMISSIONS, INCONSISTENCIES OR OTHER DEFECTS IN THE DESIGN OR CONSTRUCTION, REGARDLESS OF WHETHER SUCH ERRORS, OMISSIONS, INCONSISTENCIES OR DEFECTS WERE ALSO INCLUDED IN THE SCHEMATIC PLAN OR OTHER REFERENCE DOCUMENTS.

23.2 Restrictions

23.2.1 Subject to the releases and disclaimers herein (including Section 3.7), the DB Contractor's indemnity obligations hereunder shall not extend to any Losses incurred by an Indemnified Party to the extent caused by:

(a) the negligence, reckless or willful misconduct, bad faith or fraud of such Indemnified Party;

(b) any material defect inherent in prescriptive design or prescriptive construction specifications included in the Contract Documents, provided the DB Contractor complied with such specifications and did not actually know, or would not reasonably have known, while exercising reasonable diligence, that it was deficient or, if the DB Contractor actually knew of the deficiency, unsuccessfully sought the Mobility Authority's waiver of or approval of a Deviation from such standard;

(c) the Mobility Authority's material breach of any of its obligations under the Contract Documents; or

(d) an Indemnified Party's knowing and material violation of any Laws or Governmental Approvals which precludes development of the Project.

23.2.2 Such indemnities shall not be construed to effect any extension of statutes of limitations otherwise applicable to causes of action for breach of contract held by the Mobility Authority against the DB Contractor.

23.2.3 Such indemnities shall apply to third party claims only and shall not be enforceable by the Indemnified Parties as an additional remedy for Losses otherwise compensable through a

direct action of the Indemnified Parties against the DB Contractor due to the DB Contractor's actions or omissions.

23.3 Employee Claims

In claims by an employee of any member of the DB Contractor Group, the indemnification obligation under Section 23.1 shall not be limited by a limitation on the amount or type of damages, compensation or benefits payable by or for the DB Contractor or a Subcontractor under workers' compensation, disability benefit or other employee benefits laws.

23.4 No Relief from Responsibility

No rights of the Mobility Authority described in Section 23.1.1 above, no exercise or failure to exercise such rights, and no certificates or statements by the Mobility Authority regarding completion or acceptance, shall:

- (a) Relieve the DB Contractor of its responsibility for the selection and the competent performance of all members of the DB Contractor Group;
- (b) Relieve the DB Contractor of any of its obligations or liabilities under the Contract Documents;
- (c) Be deemed or construed to waive any of the Mobility Authority's rights and remedies under the Contract Documents, applicable Law or in equity; or
- (d) Be deemed or construed as any kind of representation or warranty, express or implied, by the Mobility Authority.

23.5 Right to Rely

Notwithstanding the provisions of Section 23.4, (a) the DB Contractor shall be entitled to rely on specific written Deviations the Mobility Authority gives under this DB Agreement, (b) the Mobility Authority is not relieved from any liability arising out of a material misrepresentation under any written statement the Mobility Authority knowingly and intentionally delivers, and (c) the Mobility Authority is not relieved from its obligations under the Contract Documents.

23.6 Survival

The indemnifications and releases under this DB Agreement, including under this Section 23 shall survive the completion of the Project and/or expiration or termination of this DB Agreement and/or any other Contract Document(s).

23.7 Intent of Indemnity for Breach of Contract

The requirement to provide indemnities for acts, omissions, errors, inconsistencies, defects, negligence and/or breach of contract set forth in Sections 23.1.1(a), 23.1.1(d) and 23.1.2 are intended to provide protection to the Mobility Authority with respect to third party claims associated with such breach. It is not intended to provide the Mobility Authority with an alternative cause of action for damages incurred directly by the Mobility Authority with respect to a breach

by the DB Contractor, nor is this paragraph intended to limit the Mobility Authority's remedies other than as specifically stated herein.

24. TORT LIABILITY

24.1 Notice of Claims

The Parties agree to provide to each other's authorized representative written notice of any claim which such Party may receive from any third party relating in any way to the matters addressed in this DB Agreement, and shall otherwise provide notice in such form and within such period as is required by Law.

24.2 Limitation on Mobility Authority's Liability

In no event shall the Mobility Authority or any other Indemnified Party be liable for injury, damage, or death sustained by reason of a defect or want of repair on or within the Site during the period the DB Contractor has operation and control of the Site, nor shall the Mobility Authority be liable for any injury, damage or death caused by the actions, omissions, negligence, willful misconduct, or breach of applicable Law or contract by any member of the DB Contractor Group. The DB Contractor expressly acknowledges and agrees that the Mobility Authority's rights in this DB Agreement to take any action with respect to the Project, including the right to review, comment on, disapprove and/or accept designs, plans, specifications, work plans, construction, installation, traffic management details, safety plan and the like, are discretionary in nature and exist solely for the benefit and protection of the Mobility Authority and do not create or impose upon the Mobility Authority any standard or duty of care toward the DB Contractor or any other Person, all of which are hereby expressly disclaimed.

25. DISPUTE RESOLUTION

25.1 General Dispute Resolution Provisions

25.1.1 Nature of Process

Partnering, as described in *Section 2.3* and in *Technical Provision 1*, will be encouraged in preference to the more formal dispute resolution mechanisms provided in this DB Agreement. Partnering in this context is intended to be a voluntary, non-binding procedure available for use by the Parties to this DB Agreement to resolve any issues that may arise during performance of the Work.

In the event partnering fails to resolve an issue and the DB Contractor elects to pursue a formal Dispute with the Mobility Authority, the Dispute shall be resolved using the procedures, methods and decision body provided by this *Section 25*.

25.1.2 Continuation of Work

At all times during this dispute resolution process or any subsequent administrative, arbitration or court proceeding, the DB Contractor and all Subcontractors shall proceed with the Project diligently, without delay, in accordance with this DB Agreement, and as directed by the Mobility Authority, so long as the Mobility Authority continues to pay the DB Contractor for that

part of the Work that is undisputed. The DB Contractor acknowledges that it shall be solely responsible for any Project delay that results from its actions or inactions during the dispute resolution process, even if the DB Contractor's position in connection with the Dispute ultimately prevails. In addition, all Parties shall continue to comply with all provisions of the Contract Documents, the Governmental Approvals and applicable Law.

25.1.3 Exclusive Jurisdiction and Venue

The DB Contractor agrees that the exclusive jurisdiction and venue for any legal action or proceeding, at law or in equity, arising out of or relating to the Contract Documents or the Project, shall be the District Court in Austin, Texas. The DB Contractor waives all objections it might have to the jurisdiction or venue of such court and hereby consents to such court's jurisdiction, regardless of the DB Contractor's residence or domicile, for any such action or proceeding.

25.2 Purpose

25.2.1 **Purpose.** A disputes review board (the "**Disputes Board**") will be established to assist in the resolution of disputes arising out of the Work. This Section 25 describes the purpose, procedure, function, and key features of the Disputes Board. The execution of a Disputes Board Agreement will formalize the creation of the Disputes Board.

25.2.2 **Duties.** The Disputes Board will assist in and facilitate the timely and equitable resolution of disputes between the Mobility Authority and the DB Contractor, in an effort to avoid construction delay and litigation. It is not the intent of the Dispute Board to serve as a channel for the Mobility Authority or the DB Contractor to bypass or default on the normal responsibility to amicably and fairly settle their differences by indiscriminately forwarding or assigning them to the Disputes Board for resolution. It is intended that the Disputes Board encourage the Mobility Authority and the DB Contractor to resolve potential disputes without resorting to this formal appeal procedure.

25.3 Disputes Board Membership

25.3.1 **General.** A Disputes Board shall be established and begin operation upon DB Agreement execution by the Mobility Authority and the DB Contractor, and shall terminate upon completion of all work required to be performed by the DB Contractor on the Project unless sooner in accordance with applicable law.

25.3.2 **Board Members.** The Disputes Board shall initially consist of two members, one selected by the Mobility Authority and one selected by the DB Contractor. The first duty of the Disputes Board shall be to select its third member. The third member selected shall be approved by both the Mobility Authority and the DB Contractor. The third member will serve as the chairman for all Disputes Board activities. The goal in selecting the third member is to complement the dispute resolution experience of the first two and to provide leadership for the Disputes Board's activities.

25.3.3 **Experience.** It is desirable and required that all Disputes Board members be experienced with highway design, construction, and environmental compliance, as well as experience in the resolution of disputes involving interpretation of design-build contracts.

25.3.4 Selection Process

Each Party shall select its Disputes Board member within six weeks after award of this DB Agreement and provide information regarding the selected individual to the other Party. Immediately upon approval of the first two members, the two members shall begin selection of the third member. The first two members shall ensure that the third member meets all of the criteria listed above. The third member shall be selected within four weeks after the first two members are notified to proceed with the selection. In the event of an impasse in selection of the third member, that member shall be selected by mutual agreement of the Mobility Authority and the DB Contractor. In so doing, they may, but are not required to, consider the nominees offered by the first two members. If the Mobility Authority and the DB Contractor cannot agree in the selection of the third member, then each party may submit a list of up to five candidates to a court of competent jurisdiction, pursuant to Section 25.1.3, for judicial resolution of the selection of the third member.

25.3.5 Conflict of Interest

It is imperative that Disputes Board members show no partiality to either the DB Contractor or the Mobility Authority, or have any conflict of interest. Accordingly, the following rules are applicable:

25.3.5.1 Members must not have an ownership interest in the Mobility Authority or the DB Contractor, or a financial interest in this DB Agreement or the Project, or in the outcome of any dispute decided on the Project, except for payment for serving on the Disputes Board.

25.3.5.2 No member shall have ever been previously employed (or have his/her employer employed) by the Mobility Authority, TxDOT, FHWA, the DB Contractor or any affiliate, within two years prior to the Effective Date, except for fee-based consulting services on other projects which are disclosed to all parties, or having had financial ties to, any party to this DB Agreement.

25.3.5.3 No member shall have had substantial prior involvement in the Project or relationship with any party or affiliate of a nature which would be grounds for disqualification by a judge or which could otherwise compromise his or her ability to impartially resolve disputes.

25.3.5.4 No member shall accept employment with the Mobility Authority, TxDOT, FHWA, the DB Contractor or any affiliate during the term of the Project and for so long thereafter as any obligations remain outstanding under the Contract Documents, except as a member of other disputes boards.

25.3.5.5 No member shall discuss employment with the DB Contractor, any affiliate, the Mobility Authority, TxDOT, FHWA, or any consultants working on the Project during the term of the Project and for so long thereafter as any obligations remain outstanding under the Contract Documents.

25.3.5.6 Each Board Member, in the performance of his or her duties on the Disputes Board, is acting as an independent contractor and not as an employee of either the Mobility Authority or the DB Contractor.

25.3.6 Submission of Disclosure Statements

Before a Board Member appointment is final, the first two prospective members shall submit complete disclosure statements for the approval of both the Mobility Authority and the DB Contractor. Each statement shall include a resume of experience, together with a declaration describing all past, present and anticipated or planned future relationships to the Project and with all parties involved in this DB Agreement, including disclosure of past or current professional or close personal relationships with TxDOT, FHWA, the DB Contractor, any affiliate, the Mobility Authority or its consultants working on the Project, or with any key member of any such entity. The third Disputes Board member shall supply such a statement to the first two Disputes Board members and to the Mobility Authority and the DB Contractor before his or her appointment is final.

25.3.7 Execution of Agreements

Promptly upon approval of the Disputes Board members, the Mobility Authority, the DB Contractor and the individual Disputes Board members shall enter into individual three-party Disputes Board Agreements which set forth the terms and conditions which apply to the services to be provided by the members. The Mobility Authority, the DB Contractor, and all three members of the Disputes Board shall execute the Disputes Board Agreement within four weeks after the selection of the third member.

25.3.8 Withdrawal; Termination; Replacements

Board Members may withdraw from the Disputes Board upon delivery of written notice of withdrawal to the Mobility Authority, the DB Contractor, and the other Board Members. Notice shall specify a withdrawal date of at least 28 Calendar Days following the date of delivery of the notice. In addition, a member may be terminated by the Mobility Authority or the DB Contractor if at any time that member fails to meet the qualifications set forth in this Section 25 of this DB Agreement. Should the need arise to appoint a replacement Board Member, the replacement member shall be appointed in the same manner as provided by this Section 25 for appointment of the original member. The selection of a replacement Board Member shall begin promptly upon notification of the necessity for a replacement, and shall be completed within 28 Calendar Days thereafter. The change in Disputes Board membership shall be evidenced by the new member's signature on the new three-party Disputes Board Agreement.

25.4 Disputes Board Operations

The Disputes Board shall formulate its own rules of operation in accordance with the Disputes Board Agreement.

25.4.1 Progress Reports

In order to keep abreast of design and construction development and progress, the members will be provided regular written progress reports and other relevant data mutually agreed upon by the Mobility Authority and the DB Contractor.

25.4.2 Regular Meetings

The Disputes Board shall visit the Project and meet with representatives of the Mobility Authority and the DB Contractor at regular intervals and at times of critical events. The frequency of these visits shall be as agreed among the Mobility Authority, the DB Contractor and the Disputes Board, depending on the progress of the Work. The regular meetings shall be held at the job site. Each meeting shall consist of an informal round table discussion followed by a field inspection of the Project. The round table discussion shall be attended by selected personnel from the Mobility Authority and the DB Contractor. The agenda shall generally include the following:

- (a) Meeting convened by the chairman of the Disputes Board;
- (b) Opening remarks by the Mobility Authority's representative;
- (c) A description by the DB Contractor of the Work accomplished since the last meeting, current status of the Project Schedule, schedule for future Work, potential disputes and proposed solutions for any problems;
- (d) Discussion by the Mobility Authority's representative of the Project Schedule as the Mobility Authority views it, potential disputes, and status of past disputes; and
- (e) Set tentative date for next meeting.

If it is considered necessary by all parties, the Disputes Board or the DB Contractor will prepare minutes of regular meetings and circulate them for comments, revisions, and/or approval of all concerned.

The field inspection shall cover all active segments of the Work. Representatives of both the Mobility Authority and the DB Contractor shall have the right to accompany the Disputes Board on field inspections.

25.4.3 External Communications

The Parties are expressly prohibited from seeking advice from, consulting with, or discussing any aspect of an existing or potential dispute with, any member of the Disputes Board, unless duly authorized representatives of both Parties agree in writing. A Board Member who has external contact with a party or party representative shall be subject to removal from the Disputes Board for cause.

25.5 Schedule for Dispute Resolution

25.5.1 Impartiality of Disputes Board

The Disputes Board shall fairly and impartially consider disputes referred to it, and shall provide written recommendations to the Mobility Authority and the DB Contractor, to assist in the resolution of disputes submitted to the Disputes Board.

25.5.2 Time Periods

Disputes shall be considered as quickly as possible, taking into consideration the particular circumstances and the time required to prepare detailed documentation. Steps may be omitted as agreed by both parties, and the time periods stated below may be shortened in order to hasten resolution.

Dispute Escalation Tiers				
<i>Tier</i>	<i>Level of Authority and Responsibility</i>			<i>Time Limit*</i>
	<i>DB Contractor</i>		<i>Mobility Authority</i>	
1	Design Discipline Lead or Superintendent	and	Design Lead or Lead Inspector	7 days
2	Design, Construction, or Project Controls Manager	and	Design, Construction, or Project Controls Manager	7 days
3	Project Manager	and	Project Manager	7 days
4	Designated DB Contractor Executive	and	Mobility Authority Director of Engineering	7 days
5	DB Contractor CEO or other Designated Executive	and	Mobility Authority Deputy Executive Director	7 days

** Time (in working days) in which dispute must be resolved or passed on to the next tier.*

25.5.3 Disputes Board Submittals

Before the DB Contractor shall have the right to submit a dispute to the Disputes Board, it must first comply with the following procedures.

25.5.3.1 Written Protest Procedure: If the DB Contractor objects to any decision, action or order of the Mobility Authority (including any rejection or modification of a proposed Change Order by the Mobility Authority), the DB Contractor may file a written protest with the Mobility Authority, stating clearly, and in detail, the basis for the objection, within one week after the date on which the DB Contractor first becomes aware of the decision, action or order. In the event any such protest is not filed within this time period, the DB Contractor shall be deemed to have waived the right to collect any and all costs incurred prior to the date of delivery of the protest, and shall be deemed to have waived the right to seek an extension of the Completion Deadlines with respect to any delay in the Critical Path which occurred prior to the date of the protest. This waiver shall occur whether or not there is any showing of prejudice to the Mobility Authority resulting from the delay in filing the protest. In no event may the DB Contractor submit to the Disputes Board a decision with respect to the testing and adequacy of construction materials.

25.5.3.2 Issuance of Mobility Authority Decision: The Mobility Authority will consider the written protest and make its decision (the "**Mobility Authority Decision**") on the basis of the pertinent Contract Document requirements, together with the facts and circumstances involved in the Dispute. The decision will be furnished in writing to the DB Contractor, within two weeks after receipt of the DB Contractor's written protest, provided that if no written decision is issued, the Mobility Authority shall be deemed to have denied the DB Contractor's written protest and a Mobility Authority Decision to that effect shall be deemed received by the DB Contractor at the end of such two-week period. This decision shall be final

and conclusive on the subject, unless a written appeal to Mobility Authority is filed by the DB Contractor within 30 Days of receiving the Mobility Authority Decision.

25.5.3.3 Finality of Decision: If a written appeal is submitted to the Mobility Authority, both parties shall pursue the matter further to attempt to settle the dispute. If the Mobility Authority fails to issue a new decision within two weeks after the date on which the appeal is submitted, the existing Mobility Authority decision shall be final and conclusive at the end of such two-week period. If the Mobility Authority issues a new decision within such two-week period, such decision shall be the Mobility Authority decision and shall be final and conclusive on the date it is issued.

25.5.3.4 Submittal of Dispute: If the Mobility Authority decision does not resolve the Dispute, then either Party may submit the dispute to the Disputes Board, or, if the Disputes Board does not then exist, directly to the courts. The dispute shall be submitted to the Disputes Board by written notice of appeal, delivered to the Disputes Board and simultaneously served upon the other party. The notice of appeal (or complaint if the Disputes Board does not exist) shall be filed and served within thirty (30) Calendar Days following the date on which the Mobility Authority decision becomes final, and shall state clearly and in full detail the specific issues of the dispute to be considered. If no notice of appeal or complaint is filed within thirty (30) Days following the date upon which the Mobility Authority decision is final, the Mobility Authority decision shall be final, conclusive and binding upon the parties.

25.5.3.5 Continuance of Work during Dispute: At all times during the course of the dispute resolution process, the DB Contractor shall continue with the Work as directed, in a diligent manner and without delay, or shall conform to the Mobility Authority's decision or order, and shall be governed by all applicable provisions of the Contract Documents. Records of the Work shall be kept in sufficient detail to enable payment in accordance with applicable provisions in the Contract Documents, if this should become necessary.

25.5.4 Date of Hearing

When a dispute is appealed to the Disputes Board, the Disputes Board, with input from the DB Contractor and the Mobility Authority, shall first decide when to conduct the hearing. If the matter is not urgent, it may be heard at the next regular Disputes Board meeting. For an urgent matter, the Disputes Board shall meet at its earliest convenience.

25.5.5 Discovery and Evidence

Once a notice of appeal is filed with the Disputes Board, discovery shall be permitted to the extent provided for in the Disputes Board Agreement. During the hearing, the DB Contractor and the Mobility Authority shall each have ample opportunity to be heard and to offer evidence.

25.5.6 Disputes Board Recommendation

The Disputes Board's recommendations for resolution of the dispute will be given in writing, to both the Mobility Authority and the DB Contractor, within two weeks of completion of the hearings. In exceptionally difficult cases, this time may be extended by mutual agreement of all parties. Following delivery of the recommendation, if requested by either party, the Disputes

Board shall meet with the Mobility Authority and the DB Contractor to provide additional clarification of its recommendation.

25.5.7 Response

Within two weeks of receiving the Board's recommendations, or such other time specified by the Disputes Board, both the Mobility Authority and the DB Contractor shall respond to the other and to the Disputes Board in writing, signifying either acceptance or rejection of the Disputes Board's recommendations. The failure of either party to respond within the specified period shall be deemed an acceptance of the Disputes Board's recommendations. If with the aid of the Disputes Board's recommendations, the Mobility Authority and the DB Contractor are able to resolve their dispute, the Mobility Authority will promptly process any required Change Orders.

25.5.8 Further Appeal

Should the dispute remain unresolved, during the six-month period following issuance of the Disputes Board recommendations, either party may appeal the decision back to the Disputes Board, may submit the dispute to judicial resolution or may resort to other methods of settlement. If the dispute has not been submitted to judicial resolution within such six-month period, and there has been no agreement between the parties for resolution of the dispute, then the parties shall be deemed to have conclusively agreed to accept the recommendation made by the Disputes Board.

25.5.9 Disputes Board Recommendations Not Admissible

Although both the Mobility Authority and the DB Contractor should place great weight on the Disputes Board recommendations, no such recommendation will be admissible as evidence in any subsequent litigation or other dispute resolution proceeding, except where the parties agree to resolve the dispute as set forth in Section 25.5.7.

25.6 Hearing

25.6.1 Location of Hearings

Normally the hearing will be conducted near the jobsite. However, any location that would be more convenient and still provide all required facilities and access to necessary documentation is satisfactory. Private sessions of the Disputes Board may be held at any convenient location.

25.6.2 Conduct and Record of Hearing

The third member of the Disputes Board will act as chairman of the hearing, or he or she may appoint one of the other members to be chairman. Normally each member keeps his or her own notes, and a formal transcript is not prepared. In special cases, when requested by either party, the Disputes Board may allow preparation of a transcript by a court reporter. Audio or video recordings are not permitted without approval by both the Mobility Authority and the DB Contractor.

25.6.3 Hearing Procedures

The Mobility Authority and the DB Contractor shall have representatives at all hearings. The DB Contractor will first discuss the dispute, followed by the Mobility Authority. Each party will then be allowed successive rebuttals until all aspects are fully covered. The Disputes Board members may ask questions, request clarification, or ask for additional data. In large or complex cases, additional hearings may be necessary in order to consider and fully understand all the evidence presented by both parties. Both the Mobility Authority and the DB Contractor shall be provided full and adequate opportunity to present all of their evidence, documentation and testimony regarding all issues before the Disputes Board. During the hearings, no Disputes Board member shall express any opinion concerning the merit of any facet of the case.

25.6.4 Recommendations of Disputes Board

After the hearings are concluded, the Disputes Board shall meet to formulate its recommendations. All Disputes Board deliberations shall be conducted in private, with all individual views kept strictly confidential. The Disputes Board's recommendations, together with an explanation of its reasoning, shall be submitted as a written report to both parties. The recommendations shall be based on the pertinent Contract Documents requirements, applicable Laws, and the facts and circumstances involved in the dispute. The Disputes Board shall make every effort to reach a unanimous recommendation. If this proves impossible, the dissenting member may prepare a minority report.

25.7 Compensation

Fees and expenses of all three members of the Disputes Board shall be shared equally by the Mobility Authority and the DB Contractor. The Mobility Authority will provide administrative services, such as conference facilities and secretarial services, and will have the right to require the DB Contractor to pay for half of the cost of these services. If the Disputes Board desires special services, such as legal consultation, accounting, data research, and the like, both parties must agree, and the costs will be shared by them as mutually agreed. The DB Contractor shall pay the invoices of all Disputes Board members after approval by both parties. The DB Contractor will then bill the Mobility Authority for 50% of such invoices.

No Board Member will be entitled to any employee benefits.

25.7.1 Expenses

25.7.1.1 **Payment.** Payment for services rendered by each Board Member and for their direct, non-salary expenses shall be calculated in accordance with the payment schedule for Board Member as agreed upon by the Mobility Authority, the DB Contractor, and the Board Member.

25.7.1.2 **Invoices.** Invoices for payment for work completed shall be submitted no more often than once per month. Such invoices shall be in a format approved by the Mobility Authority and accompanied by a general description of activities performed during this period. The value of work accomplished for payment shall be established from the billing rate and hours expended by the Board Member together with direct, non-salary expenses. Billings for

expenses shall include an itemized listing supported by copies of the original bills, invoices, expense accounts, and miscellaneous supporting data.

25.7.1.3 **Records.** Each Board Member shall keep available for inspection, for a period of five years after final payment, the cost records and accounts pertaining to the Disputes Board Agreement.

25.8 Cooperation

The parties shall diligently cooperate with one another and the Disputes Board, and shall perform such acts as may be necessary to obtain a prompt and expeditious resolution of the dispute. Participation in the Disputes Board process shall be a prerequisite to the filing of litigation by either party, except where necessary to meet any applicable statute of limitations.

25.9 Provisional Remedies

Subject to *Section 25.1.3*, no party shall be precluded from initiating a proceeding in a court of competent jurisdiction for the purpose of obtaining any emergency or provisional remedy which may be necessary, to protect its rights, including temporary and preliminary injunctive relief, attachment, claim and delivery, receivership and any extraordinary writ.

25.10 Participation in Other Proceedings

The DB Contractor agrees that at the Mobility Authority's request, the DB Contractor will allow itself to be joined as a participant in any arbitration or other proceeding that involves the Mobility Authority and any other participant in the design or construction of any part of the Project. This provision is for the benefit of the Mobility Authority and not for the benefit of any other party.

25.11 Governing Law

The three-party Disputes Board Agreement shall be governed by and construed in accordance with the law of the State of Texas.

26. DOCUMENTS AND RECORDS

26.1 Escrowed Proposal Documents

Prior to execution of this DB Agreement, the DB Contractor delivered into escrow one copy of all documentary information used in preparation of the DB Price (the "EPDs"). Upon execution of this DB Agreement, the EPDs shall be transferred from escrow and held in locked fire-proof cabinet(s) supplied by the DB Contractor and located in the Mobility Authority's Project offices or such other location agreed to by the Mobility Authority and the DB Contractor, with the key held only by the DB Contractor. Concurrently with approval of each Change Order or amendment to any Contract Document, one copy of all documentary information used in preparation of the Change Order or amendment shall be added to the cabinet to be held with the other EPDs. The EPDs will be held in such cabinet or otherwise maintained until all of the following have occurred: (a) 180 Days have elapsed from the later of Project Final Acceptance or termination of this DB Agreement, as applicable; (b) all disputes regarding the Work have been settled; and (c) Final Payment has been made and accepted.

26.1.1 Availability for Review

The EPDs shall be available during business hours for joint review by the DB Contractor, the Mobility Authority, TxDOT, and any dispute resolver in accordance with Section 25, in connection with approval of the Project Schedule, negotiation of Change Orders and resolution of disputes under the Contract Documents, and also as described in Section 26.1.6. The Mobility Authority shall be entitled to review all or any part of the EPDs in order to satisfy itself regarding the applicability of the individual documents to the matter at issue.

26.1.2 Proprietary Information

Although the EPDs will reside in the Mobility Authority's office, the EPDs are, and shall always remain, the property of the DB Contractor and shall be considered to be in the DB Contractor's possession, subject to the Mobility Authority's right to review the EPDs as provided in this Section 26. The DB Contractor will have and control the keys to the filing cabinet containing the EPDs. The Mobility Authority acknowledges that the DB Contractor may consider that the EPDs constitute trade secrets or proprietary information. The Mobility Authority agrees to maintain the confidentiality of information contained in the EPDs and not to use such information for any purpose other than in connection with the Project.

26.1.3 Representation

The DB Contractor represents and warrants that the EPDs constitute all documentary information used in the preparation of its DB Price. The DB Contractor agrees that no other price proposal preparation information will be considered in resolving disputes or claims. The DB Contractor further agrees that the EPDs are not part of the Contract Documents and that nothing in the EPDs shall change or modify any Contract Document.

26.1.4 Contents of EPDs

The EPDs shall, inter alia, clearly detail how each price included in the Proposal has been determined and shall show prices and price elements in sufficient detail as is adequate to enable the Mobility Authority to understand how the DB Contractor calculated the DB Price. The EPDs provided in connection with quotations and Change Orders shall, inter alia, clearly detail how the total price and individual components of that price were determined. The EPDs shall itemize the estimated costs of performing the required work separated into usual and customary items and cost categories and sub-items and cost categories to present a detailed estimate of costs, such as direct labor, repair labor, equipment ownership and operation, expendable materials, permanent materials, Subcontract costs, plant and equipment, indirect costs, contingencies, mark-up, overhead and profit. The EPDs shall itemize the estimated annual costs of insurance premiums for each coverage required to be provided by the DB Contractor under Section 10. The EPDs shall include all assumptions, detailed quantity price reductions, rates of production and progress calculations, and quotes from Subcontractors used by the DB Contractor to arrive at the DB Price, amendment price or Change Order price.

26.1.5 Form of EPDs

Except as otherwise provided in the RFDP, the DB Contractor shall submit the EPDs in such format as is used by the DB Contractor in connection with its Proposal. The DB Contractor

represents and warrants that the EPDs provided with the Proposal were personally examined by an authorized officer of the DB Contractor prior to delivery, and that the EPDs meet the requirements of Section 26.1.4. The DB Contractor further represents and warrants that the EPDs provided in connection with quotations and Change Orders will be personally examined prior to delivery by an authorized officer of the DB Contractor, and that they shall meet the requirements of Section 26.1.4.

26.1.6 Review by Mobility Authority

The Mobility Authority may at any time conduct a review of the EPDs to determine whether they are complete. If the Mobility Authority determines that any data is missing from an EPD, the DB Contractor shall provide such data within three Business Days after delivery of the Mobility Authority's request for such data. At that time of its submission to the Mobility Authority, such data will be date stamped, labeled to identify it as supplementary EPD information and added to the EPD. The DB Contractor shall have no right to add documents to the EPDs except upon the Mobility Authority's request. The EPDs associated with any Change Order or amendment to this DB Agreement shall be reviewed, organized and indexed in the same manner described in Section 4.5 of the Instructions to Proposers.

26.2 Subcontract Pricing Documents

The DB Contractor shall require each Subcontractor to preserve all documentary information used in establishing its Subcontract price and to provide such documentation to the DB Contractor and/or the Mobility Authority in connection with any claim exceeding \$250,000 made by such Subcontractor.

26.3 Reporting Requirements

26.3.1 The DB Contractor shall deliver to the Mobility Authority financial and narrative reports, statements, certifications, budgets and information as and when required under this DB Agreement.

26.3.2 The DB Contractor shall furnish, or cause to be furnished, to the Mobility Authority such information and statements as the Mobility Authority may reasonably request from time to time for any purpose related to the Project, this DB Agreement or the other Contract Documents. In addition, the DB Contractor shall deliver to the Mobility Authority the following financial statements for each Guarantor, at the times specified below:

26.3.2.1 [RESERVED]

26.3.2.2 Within 120 Days after the end of each fiscal year, duplicate copies of the balance sheet and a consolidated statement of financial condition of the Guarantor and its consolidated subsidiaries at the end of such year, and statements of earnings, changes in financial position of the Guarantor and its consolidated subsidiaries for such year, setting forth in each case in comparative form the figures for the previous fiscal year, all in reasonable detail and accompanied by an opinion thereon of an independent public accountant of recognized national standing selected by the Guarantor, which opinion shall state that such financial statements have been prepared in accordance with generally accepted accounting principles consistently applied (except for changes in application in which such accountants concur), and that the examination of

such accountants in connection with such financial statements has been made in accordance with generally accepted auditing standards, and accordingly, included such tests of the accounting records and such other auditing procedures as were considered necessary in the circumstances; and

26.3.2.3 Upon request of the Mobility Authority for particular fiscal quarters, copies of all other financial statements and information reported by the Guarantor to its shareholders generally and of all reports filed by the Guarantor with the Securities Exchange Commission under Sections 13, 14 or 15(d) of the Exchange Act, to be provided to the Mobility Authority as soon as practicable after furnishing such information to the Guarantor's shareholders or filing such reports with the Securities and Exchange Commission, as the case may be.

26.3.3 The DB Contractor shall cooperate and provide, and shall cause the Subcontractors to cooperate and provide, such information as determined necessary or desirable by the Mobility Authority in connection with the Project financing, including Bond financing, and applications for state and federal assistance (including TIFIA credit and other federal or state financial assistance). Without limiting the generality of the foregoing, the DB Contractor shall provide such information deemed necessary or desirable by the Mobility Authority for inclusion in the Mobility Authority's securities disclosure documents and in order to comply with Securities and Exchange Commission Rule 15c2-12 regarding certain periodic information and notice of material events. The DB Contractor shall provide customary representations and warranties to the Mobility Authority and the capital markets as to the correctness, completeness and accuracy of any information furnished.

26.3.4 The DB Contractor shall cooperate and provide, and shall cause the Subcontractors to cooperate and provide, such information as is necessary or requested by the Mobility Authority to assist or facilitate the submission by the Mobility Authority of any documentation, reports or analysis required by the State, TxDOT, USDOT, FHWA and/or any other Governmental Entity with jurisdiction over the Project.

26.3.5 All reports and information delivered by the DB Contractor under Sections 26.3.3 and 26.3.4 shall also be delivered electronically, to the extent electronic files exist, and be suitable for posting on the web.

26.4 Maintenance of, Access to, and Audit of Records

26.4.1 The DB Contractor shall maintain at its Project administration office a complete set of all books and records prepared or employed by the DB Contractor in its management, scheduling, cost accounting and other activities related to the Work and the Project. The DB Contractor shall grant to the Mobility Authority such audit rights and shall allow the Mobility Authority such access to and the right to copy such books and records as the Mobility Authority may request in connection with the issuance of Change Orders, the resolution of disputes, and such other matters as the Mobility Authority reasonably deem necessary for purposes of verifying compliance with this DB Agreement and applicable Law.

26.4.2 Where the payment method for any Work is on a time and materials basis, such examination and audit rights shall include all books, records, documents and other evidence and accounting principles and practices sufficient to reflect properly all direct and indirect costs of whatever nature claimed to have been incurred and anticipated to be incurred for the performance of such Work. If an audit indicates the DB Contractor has been overpaid under a previous progress

report or progress payment, the excess payment will be credited against current progress reports or payments.

26.4.3 For cost and pricing data submitted in connection with pricing Change Orders, claims or disputes, the Mobility Authority, TxDOT, FHWA, and their representatives shall have the right to audit all books, records, documents and other data of the DB Contractor related to the performance of Work for the purpose of evaluating the accuracy, completeness and currency of the cost or pricing data submitted; provided, however, that the foregoing shall not apply to pricing based on adequate price competition, established catalog or market prices of commercial items sold in substantial quantities to the public or prices set by Law or regulation, in each case, as determined by the Mobility Authority. Such right of examination shall extend to all documents deemed necessary by the Mobility Authority, TxDOT, FHWA, and their representatives to permit adequate evaluation of the cost or pricing data submitted, along with the computations and projections used therein.

26.4.4 The DB Contractor acknowledges that the Mobility Authority wishes to obtain information regarding the cost of performance of Utility Adjustment Work. The DB Contractor agrees to provide the Mobility Authority with such reports and information as the Mobility Authority may request from time to time relating to such costs. The DB Contractor shall maintain separate records regarding utility costs incurred in performance of the Work, and shall allow the Mobility Authority access to, and the right to copy, such separate records as may be reasonably requested by the Mobility Authority from time to time, including access to back-up data that would not normally be expected to be delivered in connection with a lump sum contract. The Mobility Authority agrees that the information described in this Section 26.4.4 shall be used solely for purposes of cost tracking and shall not be relevant for purposes of determining the amount of any payment owing to the DB Contractor, provided that the foregoing shall not affect the Mobility Authority's ability to make any cost adjustment pursuant to any other provision of the Contract Documents.

26.5 Retention of Records

The DB Contractor shall maintain all records and documents relating to the Work, including copies of all original documents delivered to the Mobility Authority, and the Project in Austin, Texas until five years after the date of the expiration of all Warranties hereunder or the termination of this DB Agreement, whichever is applicable. The DB Contractor shall notify the Mobility Authority where such records and documents are kept. Notwithstanding the foregoing, all records which relate to Demands being processed or actions brought under the dispute resolution provisions hereof shall be retained and made available until such actions and Demands have been finally resolved. Records to be retained include all books, electronic information and files and other evidence bearing on the DB Contractor's costs under the Contract Documents. The DB Contractor shall make these records and documents available for audit and inspection to the Mobility Authority, at The DB Contractor's offices in Austin, Texas, at all reasonable times, without charge, and shall allow such Persons to make copies of such documents, at no expense to the DB Contractor. If approved by the Mobility Authority, photographs, microphotographs or other authentic reproductions may be maintained instead of original records and documents.

26.6 Public Records Act

26.6.1 The DB Contractor acknowledges and agrees that all records, documents, drawings, plans, specifications and other materials in the Mobility Authority's possession, including materials submitted by the DB Contractor, are subject to the provisions of the Public Information Act. The DB Contractor shall be solely responsible for all determinations made by it under such Law, and for clearly and prominently marking each and every page or sheet of materials with "Trade Secret" or "Confidential", as it determines to be appropriate. The DB Contractor is advised to contact legal counsel concerning such Law and its application to the DB Contractor.

26.6.2 If any of the materials submitted by the DB Contractor to the Mobility Authority are clearly and prominently labeled "Trade Secret" or "Confidential" by the DB Contractor, the Mobility Authority will endeavor to advise the DB Contractor of any request for the disclosure of such materials prior to making any such disclosure. Subject to Section 29.2, under no circumstances, however, will the Mobility Authority be responsible or liable to the DB Contractor or any other Person for the disclosure of any such labeled materials, whether the disclosure is required by Law, or court order, or occurs through inadvertence, mistake or negligence on the part of the Mobility Authority.

26.6.3 In the event of litigation concerning the disclosure of any material submitted by the DB Contractor to the Mobility Authority, the Mobility Authority's sole involvement will be as a stakeholder retaining the material until otherwise ordered by a court, and the DB Contractor shall be fully responsible for otherwise prosecuting or defending any action concerning the materials at its sole cost and risk; provided, however, that the Mobility Authority reserves the right, in its sole discretion, to intervene or participate in the litigation in such manner as it deems necessary or desirable. All costs and fees, including attorneys' fees and costs, incurred by the Mobility Authority in connection with any litigation, proceeding or request for disclosure shall be reimbursed and paid by the DB Contractor.

27. COOPERATION AND COORDINATION WITH OTHER CONTRACTORS AND GOVERNMENTAL ENTITIES

27.1 Cooperation with Other Contractors

The Mobility Authority reserves the right to contract with others for and perform other or additional work on or near the Site. The DB Contractor shall cooperate with such other contractors to the extent reasonably necessary for the performance by such other contractors of their work, and shall cause all members of the DB Contractor Group to so cooperate. If other separate contracts are awarded by the Mobility Authority or TxDOT which affect the Work, including work related to abutting roadways, connectors and toll collection system design, supply, installation, operation, maintenance and repair, the DB Contractor shall conduct its Work without interfering with or hindering the progress or completion of the work being performed by other contractors. The Mobility Authority shall include similar cooperative language in any other contracts for additional work on or near the Site.

27.2 Interference by Other Contractors

Except as provided in Section 27.4, if the DB Contractor asserts that any of the Mobility Authority's or TxDOT's other contractors have hindered or interfered with the progress or

completion of the Work, then the DB Contractor's sole remedy shall be to seek recourse against such other contractors.

27.3 Coordination with Governmental Entities and Contractors

The DB Contractor shall coordinate with Governmental Entities, with owners of property adjoining the Project, the toll related work participants, including the System Integrator and contractors involved with Adjacent Work as more particularly described in Technical Provision 21.

27.4 Coordination with Toll Related Project Participants; System Integrator; Delays

27.4.1 The DB Contractor shall be responsible for coordinating with the Mobility Authority's contracted System Integrator to develop and construct the toll system components of the Project in accordance with Technical Provision 21. The DB Contractor and the System Integrator shall maintain ongoing communication regarding requirements applicable and progress with respect to the intelligent system infrastructure included in the Project as it relates to the tolling system with the Mobility Authority, representatives of the Texas Department of Public Safety, and TxDOT. The DB Contractor shall not be directly responsible for payment and performance by the System Integrator; provided, however, it shall be the responsibility of the DB Contractor to integrate the equipment and services provided by the System Integrator into the DB Contractor's Project Schedule and to notify the Mobility Authority immediately if the DB Contractor determines that any action or inaction on the part of the System Integrator will prevent the DB Contractor from meeting either the Completion Deadline or the Acceptance Deadline.

27.4.2 Subject to the requirements which are generally applicable to Change Orders in Section 14, the DB Contractor shall not be entitled to an extension of the Completion Deadline or Acceptance Deadline for delays to the Critical Path resulting from the DB Contractor's inability to complete activities caused by the System Integrator's failure or inability to provide responses to proposed plans, design documents and other submittals and matters for which response is required or any other action or inaction of the System Integrator unless the DB Contractor contemporaneously with the DB Contractor's discovery of a possible delay caused by the System Integrator communicates in writing to the Mobility Authority a written description of the circumstances that it claims will result in such delay.

28. GOVERNING LAW, COMPLIANCE WITH LAW, AND REFERENCE STANDARDS

28.1 Texas Law

This DB Agreement shall be governed and construed in accordance with the laws of the State without regard to conflict of law principles.

28.2 Compliance with Laws and Federal Requirements

The DB Contractor shall comply with, and ensure that all Subcontractors comply with, all requirements of all applicable Laws, including Environmental Laws, and the Federal Requirements.

28.3 Compliance with Referenced Standards

The DB Contractor shall ensure that the Project meets the TxDOT Standards and Specifications, except to the extent that the Contract Documents specifically allow Deviations therefrom. The DB Contractor shall also ensure that the Project meets all other applicable referenced standards, except to the extent that the Contract Documents specifically allow Deviations therefrom. Unless specifically designated to the contrary, in cases where this DB Agreement refers to TxDOT Standards and TxDOT Specifications or any manual, policy, guidance document or other similar document, it shall mean the latest edition or revision thereof and amendments or supplements thereto in effect on the Proposal Date.

29. MISCELLANEOUS

29.1 Reserved Rights

Notwithstanding anything to the contrary contained in this DB Agreement or the other Contract Documents, the Mobility Authority shall retain and enjoy the Reserved Rights.

29.2 Ownership of Documents

All data, sketches, charts, calculations, plans, specifications, electronic files, correspondence and other documents created or collected by the DB Contractor under the terms of the Contract Documents, with the exception of the DB Contractor's internal privileged communications and documents with only incidental references to the Work, are the exclusive property of the Mobility Authority and the DB Contractor shall furnish the same to the Mobility Authority upon request. All documents prepared by the DB Contractor and all documents furnished to the DB Contractor by the Mobility Authority shall be delivered to the Mobility Authority upon Substantial Completion or termination of this DB Agreement. The Mobility Authority acknowledges that such documents delivered to it by the DB Contractor were developed specifically for the Project and the DB Contractor does not represent that they are suitable for use on another project. Release of any and all information shall be in conformance with the Public Information Act exclusively by and through the Mobility Authority or its designee. Upon receipt of any such public record request, the DB Contractor shall immediately notify the Mobility Authority, which shall have responsibility for the handling of such request. Prior to the release of any such information, the Mobility Authority shall provide the DB Contractor the opportunity to seek protection for any confidential information through the Texas Attorney General.

29.3 Amendments to Contract Documents

29.3.1 The Contract Documents may be amended only by a written instrument duly executed by the Parties or their respective successors or assigns. No oral agreement or implied covenant shall be held to vary the terms hereof, any statute, Law or custom to the contrary notwithstanding.

29.3.2 If any provisions of the Contract Documents are rendered obsolete or ineffective in serving their purpose by Change in Law, passage of time, financing requirements or other future events or circumstances, the Parties agree to negotiate in good faith appropriate amendments to or replacements of such provisions in order to restore and carry out the original purposes thereof to the extent practicable; provided, however, that neither Party is obligated to agree to any

amendment or replacement which would reduce its rights or enlarge its responsibilities under the Contract Documents in any material respect.

29.4 Waiver

29.4.1 No waiver by any Party of any right or remedy under the Contract Documents shall be deemed to be a waiver of any other or subsequent right or remedy under the Contract Documents. The consent by one Party to any act by the other Party requiring such consent shall not be deemed to render unnecessary the obtaining of consent to any subsequent act for which consent is required, regardless of whether similar to the act for which consent is given.

29.4.2 No act, delay or omission done, suffered or permitted by one Party or its agents shall be deemed to waive, exhaust or impair any right, remedy or power of such Party under any Contract Document, or to relieve the other Party from the full performance of its obligations under the Contract Documents. No custom or practice between the Parties in the administration of the terms of the Contract Documents shall be construed to waive or lessen the right of a Party to insist upon performance by the other Party in strict compliance with the terms of the Contract Documents.

29.4.3 No waiver of any term, covenant or condition of the Contract Documents shall be valid unless it is in writing and signed by the Party for whom such waiver is sought.

29.4.4 Unless stated expressly to the contrary in any such provision, to the extent that waivers, releases or limitations on liability or remedies are expressed in the Agreement, then all such waivers, releases or limitations shall apply as written, notwithstanding the fault, negligence, or strict liability of the party to be released or whose liability is limited, and shall extend to the officers, employees, and related entities of such party.

29.5 Relationship of Parties

The relationship of the DB Contractor to the Mobility Authority shall be one of an independent contractor, not an agent, partner, representative, joint venturer or employee. Officials, employees, partners, Subcontractors and agents of the DB Contractor shall in no event be considered employees, contractors, agents, partners or representatives of the Mobility Authority. Notwithstanding the foregoing, Persons performing professional services under this DB Agreement shall perform their services in keeping with the standard of care applicable to their profession and shall comply with all applicable requirements of the Contract Documents in performance of such services.

29.6 Assignment

Subject to the limitations of this Section 29.6, the Contract Documents shall be binding upon and shall inure to the benefit of the Parties hereto and their respective legal representatives, successors and permitted assigns, and wherever a reference in any Contract Document to any of the Parties thereto, such reference also shall be deemed to include, wherever applicable, a reference to the legal representatives, successors and permitted assigns of such Party, as if in every case so expressed.

29.6.1 The DB Contractor may not, without the prior written consent of the Mobility Authority (in its sole discretion), voluntarily or involuntarily assign, convey, transfer, pledge, mortgage or otherwise encumber its rights or interests under the Contract Documents. No partner, joint venturer, member or shareholder of the DB Contractor may assign, convey, transfer, pledge, mortgage or otherwise encumber its ownership interest in the DB Contractor without the prior written consent of the Mobility Authority, in its sole discretion.

29.6.2 The Mobility Authority may transfer and assign all or part of its interests in the Project, this DB Agreement and any other Contract Document to:

(a) any other public agency or public entity as permitted by Law, provided that the successor or assignee has assumed all of the Mobility Authority's obligations, duties and liabilities under the applicable Contract Document then in effect, and has provided the DB Contractor with reasonable assurance of its legal and financial authority to honor and perform the same; or

(b) the Bond Trustee as security for the performance of the Mobility Authority's obligations to the Bond Trustee. In the event of such an assignment, the term "Mobility Authority" as used in this DB Agreement shall be deemed to mean the Bond Trustee as assignee of the Mobility Authority, and as such assignee the Bond Trustee shall have all rights accorded to the Mobility Authority. Any Bond Trustee may, in connection with any default under any financing document, assign any rights assigned to it hereunder to any Person; or

(c) any other Person with the prior written approval of the DB Contractor and the Bond Trustee.

Notwithstanding (a), (b), or (c), the Mobility Authority may, without the consent of the DB Contractor, make a partial assignment to TxDOT of its rights and obligations under the DB Agreement that pertain to the design and construction of the non-tolled elements of the Project.

29.7 Designation of Representatives; Cooperation with Representatives and with Financing Entities

The Parties hereto shall each designate an individual or individuals who shall be authorized to make decisions and bind the Parties on all matters relating to the Contract Documents except insofar as such authority may be limited by the particular provision or the delegation of such authority in accordance with this Section 29.7. Exhibit N hereto provides the initial designations of the authorized representatives. Such designations may be changed by a subsequent writing delivered to the other Party in accordance with Section 29.12.

29.8 No Gift or Dedication

29.8.1 Nothing contained in this DB Agreement shall be deemed to be a gift or dedication of any portion of the Project, Final ROW or Work to the general public, or be deemed to create any rights to be held by the general public in the Project, Final ROW or Work except as expressly set forth herein.

29.8.2 The DB Contractor shall not, other than as provided by Law, directly or indirectly, give, offer or promise anything of value to any present or former Mobility Authority, FHWA or

TxDOT employee or consultant that might reasonably tend to influence them in the discharge of their official duties or is offered with the intent to influence official conduct, for or because of any official act performed or to be performed by such employee. The phrase "anything of value", as used herein means any item of value, including invitations or tickets to sporting events, social gatherings, outings or parties, or the provision of meals or lodging, or the use of vehicles of any kind, and any other item or thing of monetary value.

29.9 Use of Police and Other Powers

Nothing in this DB Agreement limits the authority of the Mobility Authority to exercise its regulatory, statutory and police powers granted by Law, including its powers of condemnation with respect to all or any part of the Project, the Final ROW and any of the DB Contractor's rights hereunder.

29.10 Survival

All covenants, agreements, representations and warranties made in or pursuant to the Contract Documents shall be deemed continuing and made at and as of the date of each such document and at and as of all other applicable times during the course of the Project. All covenants, agreements, representations and warranties made in or pursuant to the Contract Documents shall survive the expiration or earlier termination thereof and shall not be waived by the execution and delivery of the Contract Documents, by completion of construction, by any investigation by the Mobility Authority or by any other event except a specific written waiver by the Party against whom waiver is asserted.

29.11 No Third Party Beneficiaries

Nothing contained in the Contract Documents is intended or shall be construed as creating or conferring any rights, benefits or remedies upon, or creating any obligations of the Parties toward any Person or entity not a Party hereto, except to the extent that specific provisions (such as the warranty and indemnity provisions) identify third parties and state that they are entitled to benefits hereunder.

29.12 Notices and Communications

29.12.1 Notices under the Contract Documents shall be in writing and (a) delivered personally, (b) sent by certified mail, return receipt requested, (c) sent by a recognized overnight mail or courier service, with delivery receipt requested, or (d) sent by facsimile communication followed by a hard copy and with receipt confirmed by telephone, to those individuals designated by the DB Contractor and the Mobility Authority from time to time in writing:

DB Contractor:

Pat Pluenneke
Great Hills Constructor
1411 Green Way Drive
Irving, TX 75038
Phone: 512-619-5238
E-mail: ppluenneke@walshgroup.com

Mobility Authority:

Director of Engineering
Central Texas Regional Mobility Authority
3300 N. IH-35
Suite 300
Austin, Texas 78705
Phone: (512) 996-9778
Fax: (512) 996-9784
E-mail: msexton@CTRMA.org

In addition, copies of all notices to proceed and suspension, termination and default notices forwarded by either Party shall be delivered to the following Persons:

C. Brian Cassidy
Locke Lord LLP
600 Congress Ave.
Suite 2200
Austin, Texas 78701
Phone: (512) 305-4716
Fax: (512) 391-4716

Austin District Engineer
Texas Department of Transportation - Austin District Office
7901 N. IH-35
Austin, Texas 78753
Phone: (512) 832-7000
Fax: (512) 478-8248

All communications to the Mobility Authority shall be clearly marked with the contract number to identify this DB Agreement and the Project name and location.

29.12.2 Notices shall be deemed received when actually received in the office of the addressee, or by the addressee if personally delivered, or when delivery is refused, as shown on the receipt of the U. S. Postal Service, private carrier or other Person making the delivery. Notwithstanding the foregoing, notices sent by telefacsimile after 4:00 p.m. Central Standard or Daylight Time, as applicable, and all other notices received after 5:00 p.m. shall be deemed received on the first Business Day following delivery. As an example, in order for a fax to be deemed received on the same Day, at least the first page of the fax must have been received before 4:00 p.m. The DB Contractor's representatives shall be available at all reasonable times for consultation with the Mobility Authority.

29.12.3 The DB Contractor shall forward a copy of all written correspondence pertaining to the Project between the DB Contractor any railroad, Utility Owner, owner of any property adjacent to the Project or which may potentially be acquired in connection with the Project and any representative of any Governmental Entity to the Mobility Authority within five 5 Days after receipt thereof.

29.13 Further Assurances

Each Party shall promptly execute and deliver to other all such instruments and other documents and assurances as are reasonably requested by the other Party to further evidence the obligations of the Parties hereunder.

29.14 Severability

If any term or provision of the Contract Documents, the deletion of which would not adversely affect the receipt of any material benefit by either Party hereunder, shall be held by a court of competent jurisdiction to be invalid or unenforceable, the remainder of the Contract Documents shall not be affected thereby and each other term and provision of the Contract Documents shall be valid and enforceable to the fullest extent permitted by Law. If any clause or provision of the Contract Documents that is found to be illegal, invalid or unenforceable, the Parties agree that they shall in good faith (a) promptly meet and negotiate a substitute therefor which shall, to the greatest extent legally permissible, effect the original intent of the Parties; and (b) if necessary or desirable, apply to the court which declared such invalidity for a judicial construction of the invalidated portion to guide the negotiations.

29.15 Headings

The captions of the sections of the Contract Documents identified therein are inserted solely for convenience. Under no circumstances are they or any of them to be treated or construed as part of each such instrument, except to the extent that the provision cannot be understood without the caption.

29.16 Interpretation of Contract Documents

29.16.1 In the Contract Documents, where appropriate and unless otherwise specified: the singular includes the plural and vice versa; references to statutes or regulations include all statutory or regulatory provisions consolidating, amending or replacing the statute or regulation referred to; the words "including," "includes" and "include" shall be deemed to be followed by the words "without limitation"; references to sections, appendices or schedules are to the document in which they are contained; words such as "herein," "hereof" and "hereunder" shall refer to the entire document in which they are contained and not to any particular provision or section; words not otherwise defined which have well-known technical or construction industry meanings, are used in accordance with such recognized meanings; references to Persons include their respective permitted successors and assigns and, in the case of Governmental Entities, Persons succeeding to their respective functions and capacities; and words of either gender used herein shall include each other gender where appropriate. Unless otherwise specified, lists contained in the Contract Documents defining the Project or the Work shall not be deemed all-inclusive. Furthermore, notwithstanding the rule of law to the effect that specific provisions contained in a contract shall govern over general provisions, specific provisions in the Contract Documents which describe tasks included in the Work shall not constitute a limit on the Scope of Work, unless specifically so stated.

29.16.2 The DB Contractor acknowledges and agrees that it had the opportunity and obligation, prior to submission of its Proposal, and during the negotiation process prior to award of this DB Agreement, to review the terms and conditions of the Contract Documents and to bring

to the attention of the Mobility Authority any conflicts or ambiguities contained therein. The DB Contractor further acknowledges and agrees that it has independently reviewed the Contract Documents with legal counsel, and that it and each of its members has the requisite experience and sophistication to understand, interpret and agree to the particular language of the provisions of the Contract Documents. Accordingly, in the event of an ambiguity in or dispute regarding the interpretation of the Contract Documents, they shall not be interpreted or construed against the Party which prepared them, and instead other rules of interpretation and construction shall be utilized.

29.16.3 The final answers to the questions posed during the Proposal process shall in no event be deemed part of the Contract Documents and shall not be relevant in interpreting the Contract Documents except as they may clarify provisions otherwise considered ambiguous.

29.16.4 Headings set forth in the Contract Documents are set forth for convenience and shall not be used to interpret the terms thereof.

29.17 Approvals under Contract Documents

In all cases where approvals or consents are required to be provided under the Contract Documents by the Mobility Authority, the DB Contractor or other parties thereto, such approvals or consents shall not be withheld unreasonably except in cases where a different standard (such as sole discretion) is specified. In cases where sole discretion is specified, the decision shall not be subject to dispute resolution hereunder.

29.18 Counterparts and Electronic Signature

This instrument may be executed in two or more counterparts, each of which shall be deemed an original, but all of which together shall constitute one and the same instrument.

Electronic delivery of an executed counterpart of this instrument shall be effective as delivery of an original executed counterpart of this instrument, to the extent and as provided for in any applicable law, including the Federal Electronic Signatures in Global and National Commerce Act and the Texas Uniform Electronic Transactions Act. Each party acknowledges and agrees that they may execute this DB Agreement, using electronic signatures. Such electronic signatures are intended to authenticate this writing and to have the same force and effect as handwritten signatures.

29.19 Non-Business Days

If the date to perform any act or give any notice specified in the Contract Documents falls on a non-Business Day, such act or notice may be timely performed on the next succeeding Business Day. Notwithstanding the foregoing, requirements contained in the Contract Documents relating to actions to be taken in the event of an emergency, and other requirements for which it is clear that performance is intended to occur on a non-Business Day, shall be required to be performed as specified, even though the date in question may fall on a non-Business Day.

EXHIBIT A

ABBREVIATIONS AND DEFINITIONS

FOR

DEVELOPMENT OF THE

183 NORTH MOBILITY PROJECT

THROUGH A DESIGN-BUILD AGREEMENT

PROJECT NUMBER: 20183N22701C



BY THE

CENTRAL TEXAS REGIONAL MOBILITY AUTHORITY

EXECUTION COPY

EXHIBIT A

ABBREVIATIONS AND DEFINITIONS

Unless otherwise specified, wherever the following abbreviations or terms are used in this DB Agreement, the Scope of Work, and Technical Provisions, they shall have the meanings set forth below:

AAP	AASHTO Accreditation Program
AASHTO	American Association of State Highway and Transportation Officials
ACHP	Advisory Council on Historic Preservation
ACI	American Concrete Institute
ACT	Antiquities Code of Texas
ADA	Americans with Disabilities Act
ADT	Average Daily Traffic
AISC	American Institute of Steel Construction, Inc
ANSI	American National Standards Institute
ARC	Average Recycled Content
AREMA	American Railway Engineering Association
ASTM	American Society of Testing and Materials
ATC	Alternative Technical Concept
AVI	Automatic Vehicle Identification
AWG	American Wire Gauge
AWS	American Welding Society
BI	Base Index
BMP	Best Management Practice
BO	Biological Opinion
CADD	Computer Aided Drafting and Design
CAMPO	Capital Area Metropolitan Planning Organization
CCI	Construction Cost Index
CD-R	Compact Disc Recordable
CD ROM	Compact Disc Read Only Memory
CFR	Code of Federal Regulations
CMP	Construction Monitoring Plan
CMTA	Capital Metro Transit Authority
CO	Carbon Monoxide
CQA	Construction Quality Acceptance
CQAM	Construction Quality Acceptance Manager
CQC	Construction Quality Control

CQCM	Construction Quality Control Manager
CQMP	Construction Quality Management Plan
CRCP	Continuous Reinforced Concrete Pavement
CRP	Community Relations Program
CRPP	Community Relations Program Plan
CSAB	Cement Stabilized Abutment Backfill
CSJ	Control Section Job
CST/M&P	Construction Division, Materials and Pavement Section (TxDOT)
CTRMA	Central Texas Regional Mobility Authority
CUE	Civil/Utility Engineer
CWA	Clean Water Act
CWMP	Construction and Demolition Waste Management Plan
DB	Design-Build
DBE	Disadvantaged Business Enterprise
DEIS	Draft Environmental Impact Statement
DQA	Design Quality Assurance
DQAM	Design Quality Assurance Manager
DQC	Design Quality Control
DQMP	Design Quality Management Plan
DP	DB Price
DRB	Disputes Review Board
DSS	Decent Safe and Sanitary (dwelling)
EA	Environmental Assessment
ECI	Environmental Compliance Inspector
ECM	Environmental Compliance Manager
ED	Environmental Documents
EMR	Environmental Monitoring Report
EP	Extraction Procedure (toxicity)
EPA	United States Environmental Protection Agency
EPD	Escrowed Proposal Documents
EPIC	Environmental Permits Issues and Commitments
ESA	Endangered Species Act of 1973, as amended; Environmental Site Assessment
ESAL	Equivalent Single-Axle Load
ET	Environmental Team
ETC	Electronic Toll Collection
ETCS	Electronic Toll Collection System

FA	Final Acceptance
FAPG	FHWA’s Right-of-Way Project Development Guide
FCA	Final Construction Acceptance (Final Acceptance)
FEMA	Federal Emergency Management Agency
FONSI	Finding of No Significant Impact
FSS	Facilities Security System
FTP	File Transfer Protocol
FHWA	Federal Highway Administration
FOB	Field Operation Building
FWA	Final Warranty Acceptance
GAAP	Generally Accepted Accounting Principles
GIS	Geographical Information System
HMA	Hot Mix Asphalt
HOV	High Occupancy Vehicle
HVAC	Heating Ventilation and Air Conditioning
IA	Independent Assurance
ID	Identification
IH	Interstate Highway
IRI	International Roughness Index
ISDN	Integrated Services Digital Network
ISI	Initial Serviceability Index
ITP	Instructions to Proposers
ITS	Intelligent Transportation System
IWP	Investigative Work Plan
JSA	Job Safety Analysis
LED	Light-Emitting Diode
LPST	Leaking Petroleum Storage Tank
LRFD	Load and Resistance Factor Design
LSLS	Licensed State Land Surveyor
MAT	Materials Acceptance Testing
MOT	Maintenance of Traffic
MOU	Memorandum of Understanding
MPH	Miles Per Hour
MQAF	Materials Quality Acceptance Firm
MQAM	Materials Quality Acceptance Manager
MQAT	Materials Quality Acceptance Testing

MS4	Municipal Separate Storm Sewer System
MSE	Mechanically Stabilized Earth
MSL	Mean Sea Level
MTP	Mainline Toll Plaza
MUAA	Master Utility Adjustment Agreement
NAVD	North American Vertical Datum
NBI	National Bridge Inventory
NBIS	National Bridge Inspection Standards
NCE	Noncompliance Event
NCHRP	National Cooperative Highway Research Program
NCR	Non-Conformance Report
NEC	National Electrical Code
NEPA	National Environmental Policy Act
NFIP	National Flood Insurance Program
NHPA	National Historical Preservation Act
NHS	National Highway System
NICET	National Institute for Certified Engineering Technicians
NMP	Noise Mitigation Plan
NOI	Notice of Intent
NPDES	National Pollutant Discharge Elimination System
NRCS	National Resources Conservation Service
NTP	Notice to Proceed
OSB	Overhead Sign Bridge
OSHA	Occupational Safety and Health Administration
OSM	Office of Surface Mining
OVT	Owner Verification Testing
PA	Programmatic Agreement
PBS-1	Preliminary Project Baseline Schedule
PBS-2	Project Baseline Schedule
PCC	Portland Cement Concrete
PCO	Proposed Change Order
PCS	Pavement Condition Survey
PDA	Project Development Agreement
PH	Percent Hydrogen
PI	Plasticity Index
PM	Project Manager

PMP	Project Management Plan
POS	Project Operating System
PPDS	Project Power Distribution System
PSL	Project Specific Location
QAP	Quality Assurance Program
QC / QA	Quality Control / Quality Assurance
QMP	Quality Management Plan
RE	Resident Engineer
RFC	Released for Construction
RFDP	Request for Detailed Proposals
RFI	Request For Information
RFCQ	Request for Competing Qualifications
RHA	Rivers and Harbors Act
ROD	Record of Decision
ROW	Right-of-Way
ROWIS	Right-of-Way Information System
RPLS	Registered Public Land Surveyors
RTP	Ramp Toll Plazas
SDS	Safety Data Sheet
S.F.	Square Foot
SH	State Highway
SHPO	State Historic Preservation Officer
SI	System Integrator
SIR	Site Investigative Report
SOV	Schedule of Values
SSCB	Single Slope Concrete Barrier
SSTR	Single Slope Traffic Railing
SUE	Subsurface Utility Engineering
SW3P	Stormwater Pollution Prevention Plan
TAC	Texas Administrative Code
TCEQ	Texas Commission on Environmental Quality
TCLP	Toxicity Characteristic Leaching Procedure
THC	Texas Historical Commission
TIFIA	Transportation Infrastructure Finance and Innovation Act
TIM / OS	Turnpikes Intelligent Management / Operation System
TL	Testing Level

TMUTCD	Texas Manual on Uniform Traffic Control Devices
TPDES	Texas Pollutant Discharge Elimination System
TSI	Terminal Serviceability Index
TxDOT	Texas Department of Transportation
UAA	Utility Adjustment Agreement
UAAA	Utility Adjustment Agreement Amendment
UAR	TxDOT Utility Accommodation Rules
UCL	Utility Clearance Letter
UCS	Utility Coordination Specialist
UJUA	Utility Joint Use Agreement
UM	Utility Manager
UPA	Utility and Personnel Access-Way
UPS	Uninterruptible Power Supply
UPRR	Union Pacific Railroad
USACE	United States Army Corps of Engineers
USDOT	United States Department of Transportation
USFWS	United States Fish and Wildlife Service
USGS	United States Geological Survey
USPAP	United States Professional Appraisal Practices
VMS	Variable Message Sign
WBS	Work Breakdown Structure

AASHTO Guidelines shall mean the standards for design and construction of roadways and related facilities promulgated by American Association of State Highway and Transportation Officials.

Abbreviated Utility Assembly shall mean a compilation of utility documents in a format, and containing the documents, as described in *Technical Provision 8*.

Acceleration Costs shall mean those fully documented increased costs reasonably incurred by the DB Contractor (that is, costs over and above what the DB Contractor would otherwise have incurred) which are directly and solely attributable to increasing the rate at which the Work is performed in an attempt to complete necessary elements of the Work earlier than otherwise anticipated, such as for additional equipment, additional crews, lost productivity, overtime and shift premiums, increased supervision and any unexpected material, equipment or crew movement necessary for re-sequencing in connection with acceleration efforts and/or a Recovery Schedule.

Acceptance Deadline shall have the meaning set forth in *Section 5.2.2* of this DB Agreement.

Act shall have the meaning set forth in *Recital C* of this DB Agreement.

Additional Properties shall mean any real property (which term is inclusive of all permanent estates and interests in real property), improvements and fixtures outside of the Schematic ROW, that will be acquired in connection with the Project, including (a) the Mitigation Site and rest area sites, (b) DB Contractor-Designated ROW, and (c) any additional real property outside of the Schematic ROW that must be acquired due to a Mobility Authority-Directed Change, including any air space, surface rights and subsurface rights within such additional real property area that Mobility Authority directs the DB Contractor to acquire for the Project. The term specifically excludes (y) New Utility Property Interests and (z) any temporary easements or other temporary real property interests that the DB Contractor may deem necessary or advisable to acquire, at its own cost and expense, for work space, contractor lay-down areas, material storage areas, or other convenience of the DB Contractor.

Adjacent Work shall mean any project, work, improvement or development to be planned, designed or constructed which could or does impact the Project and/or is adjacent to the Project. Examples of Adjacent Work include proposed subdivisions, other roads constructed by Governmental Entities, site grading and drainage and other development improvement plans and Utility projects.

Adjust shall mean to perform an Adjustment.

Adjustment shall have the meaning set forth in *Technical Provision 8*.

Adjustment Permits shall mean all Governmental Approvals and any private approvals, including the consent of a property owner, necessary for any Utility Adjustment. The term specifically excludes Utility Joint Use Agreements.

Affiliate shall mean: (1) any Person which directly or indirectly through one or more intermediaries controls, or is controlled by, or is under common control with, the DB Contractor or any Major Participant, and (2) any Person for which 10% or more of the equity interest in such Person is held directly or indirectly, beneficially or of record by the DB Contractor, any Major Participant or any Affiliate of the DB Contractor under *clause (1)* of this definition. For purposes of this definition the term “control” means the possession, directly or indirectly, of the power to cause the direction of the management of a Person, whether through voting securities, by contract, family relationship or otherwise.

Alternate Procedure shall mean the alternate procedure for processing Utility Adjustments for FHWA approval pursuant to 23 C.F.R. Section 645.119, which was approved by the FHWA for TxDOT by letter dated October 16, 1973.

Alternative Technical Concept shall mean a concept developed by a Proposer, during the procurement, that requires approval by the Mobility Authority due to a deviation or deviations from the Project requirements. Alternative Technical Concepts approved by the Mobility Authority, and included in the successful Proposer’s Proposal, shall be incorporated into the Work.

Antiquities Permit shall mean a permit issued by the Texas Historical Commission to a qualified professional archeologist for performing an archeological survey or to a qualified architect (or other qualified professional) for performing work at a designated historic building or structure.

Archeological Survey shall mean a field investigation by which archeologists collect information about the location, distribution and organization of past human cultures across a project site.

Archeologist shall mean a member of the Project Environmental Team responsible for assessment of cultural resources potentially impacted by the Work.

As-Built Documents or Record Drawings shall mean the documents to be provided by the DB Contractor for the completed Project as described in the Technical Provisions.

Audited Financial Statements shall have the meaning set forth in *Section 22.2(s)* of this DB Agreement.

Austin District shall mean the Austin District of the Texas Department of Transportation.

Average Recycled Content shall mean the ratio of recycled material to total material as expressed in a percentage as determined in accordance with *Technical Provision 26*.

Base Scope Work shall mean the construction of four express lanes (two in each direction) and widening of the existing US 183 and direct connector ramps providing access between the new express lanes on US 183 and the existing express lanes on MoPac, a new shared-use path, new sidewalks, cross-street connections for bicycles/pedestrians along US 183, and other

improvements and widening necessary for the aforementioned improvements., as more particularly described in *Exhibit B* to this DB Agreement.

Baseline Schedule shall mean the Project Baseline Schedule (PBS-2), as defined herein.

Basic Configuration shall mean the following elements defining the Project as set forth in the Schematic Plan:

- (a) the mainline horizontal and mainline vertical alignments,¹
- (b) number of lanes, including auxiliary lanes,
- (c) the general location of the toll gantries,
- (d) the general location of ramps,
- (e) the general location of interchanges and the type of interchanges, if any, and
- (f) general location of sound walls.

Basic Costs shall have the meaning set forth in the definition of “Cost Differential” as set forth in this *Exhibit A*.

Basic Material shall mean any material that cannot be segregated without changing the material composition of the material component itself including but not limited to binders, aggregate, base and subbase or embankment materials, metal, finished plastic, and wood. Existing asphalt qualifies as a Basic Material when used as recycled asphalt pavement because it is difficult to separate the binder from the aggregate.

Best Efforts means the efforts that a prudent business person desirous of achieving a result would use exercising sound business judgment in similar circumstances to achieve that result as expeditiously as reasonably practical, provided, however, that a person required to use Best Efforts under the DB Agreement will not be thereby required to take actions that would result in a material adverse change in the benefits to such person under the DB Agreement

Best Management Practices shall have the meaning set forth in *Storm Water Management For Construction Activities: Developing Pollution Prevention Plans and Best Management Practices* (EPA Document 832 R 92-005).

Betterment shall mean, with respect to any Utility being Adjusted, any upgrading of such facility in the course of such Adjustment that is not attributable to the construction of the Project

[1] In determining whether a material change in Basic Configuration to the mainline alignment (item (a) of the Basic Configuration definition) has occurred, the following standards shall apply: no material change in Basic Configuration shall be deemed to have occurred as the result of any horizontal alignment or vertical alignment shift unless it causes any component of the project defined by the Schematic Plan (excluding private property access roads, drainage facilities and utility relocations) to be located outside of the Schematic ROW, or requires a re-evaluation of the Environmental Documents to be issued.

and is made solely for the benefit of and at the election of the Utility Owner; provided, however, that the following shall not be considered Betterments:

- (a) any upgrading which is required by the Project;
- (b) replacement devices or materials that are of equivalent standards although not identical;
- (c) replacement of devices or materials no longer regularly manufactured with the next highest grade or size;
- (d) any upgrading required by applicable Law;
- (e) replacement devices or materials which are used for reasons of economy (e.g., non-stocked items may be uneconomical to purchase); or
- (f) any upgrading required by the Utility Owner's written "standards."

For fiber optic Utilities, extension of an Adjustment to the nearest splice boxes shall not be considered a Betterment if required by the Utility Owner in order to maintain its written telephony standards.

In case of a dispute as to whether or not a particular upgrade to a Utility qualifies as a Betterment, the Mobility Authority and the DB Contractor shall apply the guidance and policies set forth in the TxDOT Utility Adjustment Rules; provided, however, that for purposes of said Rules, any upgrading required by the Utility Owner's written "standards" shall be deemed to be of direct benefit to the highway project.

Notwithstanding the foregoing, (a) any component of an Adjustment which is established as a betterment in the applicable Utility Adjustment Agreement shall be deemed a "**Betterment**" for purposes of this DB Agreement, and (b) in case of any discrepancy between the definition of "**Betterment**" set forth above in this *Exhibit A* and the definition of betterment set forth in a particular Utility Adjustment Agreement, the term "**Betterment**" shall have the meaning set forth in such Utility Adjustment Agreement for all Adjustments to which such Utility Adjustment Agreement applies.

Board Member shall mean a member of the Disputes Board described in *Section 25* of this DB Agreement.

Bond or **Bonds** shall mean any bond or bonds issued to fund the costs of development, design, construction, operation, repair and maintenance of the Project, except where specifically used in the context of Proposal Bond, Performance Bond, Payment Bond and Warranty Bond.

Bond Trustee shall mean the Person or Persons acting as bond trustee, paying agent or other designated representative of the bondholders under any bond indenture or resolution for the Bonds or any other indebtedness issued by the Mobility Authority to finance the Project, its legal

successor, or any other commercial bank or trust company duly organized and existing under the laws of any state or the United States of America, which is authorized under the laws of the State to exercise corporate trust powers and is subject to examination by federal authority, appointed pursuant to the Project Finance Documents as its successor or its successors.

Business Day (or Work Day) shall mean days on which the Mobility Authority is officially open for business.

Category A Personnel shall mean those individuals performing the roles listed under “Category A” in *Technical Provision 1*.

Category B Personnel shall mean those individuals performing the roles listed under “Category B” in *Technical Provision 1*.

Certified Wood shall mean wood deemed certified by the Forest Stewardship Council (<http://www.fscus.org>).

Change in Law shall mean the enactment, adoption, modification, repeal or other change in any Law that occurs after the Proposal Date, including any change in the judicial or administrative interpretation of any Law, or adoption of any new Law, which is materially inconsistent with Laws in effect on the Proposal Date, but excluding any such change in or new Law which was passed or adopted but not yet effective as of the Proposal Date.

Change Order shall mean a written order issued by the Mobility Authority to the DB Contractor delineating changes in the requirements of the Contract Documents in accordance with *Section 14* of this DB Agreement and establishing, if appropriate, an adjustment to the DB Price, the Completion Deadline or the Acceptance Deadline.

Claim shall mean a separate demand by the DB Contractor, which is disputed by the Mobility Authority, for a time extension under this DB Agreement, or payment of money or damages arising from work done on behalf of the DB Contractor in connection with this DB Agreement.

Commissioning Testing Deadline shall mean the deadline by which the DB Contractor shall have completed construction of the infrastructure required for operational testing of the toll equipment as more fully described in *Technical Provision 21*.

Community Relations Program Plan shall have the meaning set forth in *Technical Provision 4*.

Community Relations Specialist shall have the meaning set forth in *Technical Provision 4*.

Completion Deadline shall mean the deadline for achieving Substantial Completion as more fully described in *Section 5.2.1* of this DB Agreement. The lower case term "completion deadline" shall mean collectively the Completion Deadline and Acceptance Deadline.

Construction and Demolition Waste Management Plan shall mean the plan developed by the DB Contractor in accordance with *Technical Provision 26* that addresses how waste on the Project will be handled.

Construction Documents shall mean all shop drawings, working drawings, fabrication plans, material and hardware descriptions, specifications, construction quality control reports, construction quality acceptance reports and samples necessary or desirable for construction of the Project in accordance with the Contract Documents.

Construction Fund shall mean the Construction Fund established by the Project Finance Documents, and includes any separate accounts or sub-accounts established by the terms of the Contract Documents.

Construction General Permit shall mean a permit under the TPDES program for the management of storm water discharges from construction sites as more particularly described in *Technical Provision 9*.

Construction Monitoring Plan (CMP) shall mean the plan indicating times, locations, and other conditions under which monitoring of construction activities are to be performed to maintain and ensure compliance with Environmental Laws and Contract Documents as more particularly described in *Technical Provision 9*.

Construction Quality Assurance (COA) shall have the meaning set forth in *Technical Provision 2*.

Construction Quality Assurance Manager (COAM) shall have the meaning set forth in *Technical Provision 2*.

Construction Quality Control (CQC) shall have the meaning set forth in *Technical Provision 2*.

Construction Quality Control Manager (COCM) shall have the meaning set forth in *Technical Provision 2*.

Construction Quality Management Plan (CQMP) shall have the meaning set forth in *Technical Provision 2*.

Construction Work means all Work to build or construct, make, form, manufacture, furnish, install, supply, deliver or equip the Project and/or the Utility Adjustments. Construction Work includes landscaping.

Contract Documents shall mean this DB Agreement, including all exhibits, appendices, and the other documents listed in *Section 1.2* of this DB Agreement, including all amendments to the foregoing and all Change Orders issued.

Corrective Action shall mean the cleanup, removal, or stabilization of Hazardous Materials-contaminated soil and/or groundwater as required for compliance with Environmental Laws.

Cost Differential shall mean the following:

- (a) For any Unidentified Utility for which the DB Contractor is claiming an increase in the DB Price, the “**Cost Differential**” shall be the incremental increase in the “Basic Costs” described below for such Utility which is directly attributable to the lacking or inaccurate information which was included in the Existing Utility Information.

For purposes of this definition, the “Basic Costs” for the Adjustment of any Utility shall mean the costs for the following, whether incurred by the DB Contractor directly or reimbursed by the DB Contractor to a Utility Owner:

- (i) design and construction of such Adjustment, plus
- (ii) acquisition of New Utility Property Interests or compensation to the Utility Owner for relinquishment of Existing Utility Property Interests within the Final ROW required for such Adjustment.

For purposes of paragraph (a) above, any incremental increase in Basic Costs shall be determined by comparing (i) the Parties’ reasonable estimate of the actual Basic Costs which the DB Contractor will incur in Adjusting such Utility, based on the DB Contractor’s final determination of its location, ownership, type and other characteristics (referred to in this definition as the “Final Utility Information”) and in accordance with the final Adjustment design developed and approved pursuant to *Technical Provision 8* (provided, however, that for any Unidentified Utility which is not in fact Adjusted, the amount of such estimate shall be zero), with (ii) the Parties’ reasonable estimate of the Basic Costs which the DB Contractor would have incurred in Adjusting such Utility, based on the Existing Utility Information (provided, however, that for any Unidentified Utility not shown at all on the Existing Utility Information, or for which no Adjustment would have been necessary based on the Existing Utility Information, the amount of such estimate shall be zero). The estimates used for the foregoing comparisons shall comply with the requirements of *Section 14.6* of this DB Agreement. If the Parties are unable to agree upon a reasonable estimate of the actual Basic Costs which the DB Contractor will incur in Adjusting a Utility based on the Final Utility Information and final Adjustment design, then the amount of such actual Basic Costs shall be based on time and materials records pursuant to *Section 14.7* of this DB Agreement.

The calculation of the Cost Differential with respect to a particular facility shall be subject to all limitations on Change Orders set forth in *Section 14* of this DB Agreement, in addition to the following:

- (i) All estimates of Basic Costs (A) shall exclude Acceleration Costs and any other delay or disruption damages, and (B) shall be made in accordance with *Section 14.6*

of this DB Agreement (including mark-ups not to exceed the amounts specified in Section 14.7 of this DB Agreement).

- (ii) The costs for comparable items shall be determined on the same basis for each estimate prepared for a particular Utility, whether based on the Existing Utility Information or on the Final Utility Information.
- (iii) The Basic Costs and Cost Differential shall be calculated on a facility-by-facility basis, individually for each Utility facility, regardless of whether such facility is addressed together with other facilities in a single Utility Adjustment Agreement.

Critical Habitat shall mean the specific areas within a geographic area, occupied by a Threatened or Endangered Species at the time it was listed, which contain the physical or biological features that are essential to the conservation of the species and that may need special management or protection. Critical habitat may also include areas that were not occupied by the species at the time of listing but are essential to its conservation.

Critical Path shall mean each critical path on the Project Schedule, which ends on the date of Substantial Completion or the deadline for Final Acceptance, as applicable (i.e. the term shall apply only following consumption of all available Float in the schedule for Substantial Completion or Final Acceptance, as applicable). The lower case term "critical path" shall mean the activities and durations associated with the longest path(s) through the Project Schedule.

Day or day shall mean calendar days unless otherwise expressly specified.

DB Agreement (or Contract) shall mean that certain Design-Build Contract, to which this Exhibit A is attached, executed by the Mobility Authority and the DB Contractor, including any and all amendments thereto.

DB Contractor shall mean Great Hills Constructors, a joint venture between Archer Western Construction, LLC and Sundt Construction, Inc.

DB Contractor-Designated ROW shall mean any permanent interest in real property (which term is inclusive of all estates and interests in real property), improvements and fixtures outside of the Schematic ROW that the DB Contractor determines is necessary or advisable to be acquired for the Project and which acquisition is approved by the Mobility Authority to be acquired at the DB Contractor's cost and expense, excluding the New Utility Property Interests. The term specifically includes any easements required for drainage for the Project defined by the Project Design. The term specifically includes any air space, surface rights and subsurface rights within the DB Contractor-Designated ROW. The term specifically excludes any temporary easements or other temporary real property interests that the DB Contractor may deem necessary or advisable to acquire, at its own cost and expense, for excessive work space, contractor lay-down areas, material storage areas, or other convenience of the DB Contractor.

DB Contractor Group shall mean (i) the DB Contractor, (ii) partners, joint ventures and/or members in or with the DB Contractor, (iii) Subcontractors (including Suppliers), (iv) any

other Persons performing any of the Work, (v) any other Persons for whom the DB Contractor may be legally or contractually responsible, and (vi) the employees, agents, officers, directors, shareholders, representatives, consultants, successors, assigns and invitees of any of the foregoing.

DB Contractor-Managed Utility Adjustment Agreement shall mean a Utility Adjustment Agreement providing for construction by the DB Contractor of the Utility Adjustment(s) addressed therein.

DBE Performance Plan shall mean the DB Contractor's plan for meeting the DBE participation goals submitted with its Proposal.

DBE Program shall mean that program used by the Mobility Authority for federally assisted projects such as the Project, as set forth in *Exhibit H* to this DB Agreement.

Deferred Work shall mean the design and construction of an additional direct connector ramp from the new southbound US 183 express lanes to the Loop 1 general purpose lanes providing local access from southbound US 183 to Steck Ave, Anderson Lane and Far West Blvd., as more particularly described in *Exhibit B* to this DB Agreement.

Delay Event shall have the meaning set forth in *Section 17.3* of this DB Agreement.

Design Acceptance shall have the meaning set forth in *Technical Provision 2*.

DB Price shall mean the price set forth in *Section 13.1* of this DB Agreement, as it may be modified from time to time in accordance with the express provisions of this DB Agreement.

Design Documents shall mean all drawings (including plans, elevations, sections, details and diagrams), specifications, reports, calculations, records and submittals necessary for, or related to, the design of the Project in accordance with the Contract Documents, the Governmental Approvals and applicable Law.

Design Exception shall mean a deviation from the Project design criteria and any design standards referenced in the Contract Documents. A Design Exception requires written approval by the Mobility Authority, TxDOT, FHWA, and other agencies depending on the deviation for which approval is sought.

Design Firm shall mean the qualified Registered Professional Engineer's firm responsible for the design of the Project.

Design Quality Assurance (DQA) shall have the meaning set forth in *Technical Provision 2*.

Design Quality Assurance Manager (DQAM) shall have the meaning set forth in *Technical Provision 2*.

2. **Design Quality Control (DQC)** shall have the meaning set forth in *Technical Provision*

Design Quality Management Plan (DQMP) shall have the meaning set forth in *Technical Provision 2*.

Design Work means all Work of design, engineering, or architecture for the Project or Utility Adjustments.

Deviations shall mean any change, deviation, modification or alteration from the requirements of the Contract Documents, applicable Law and the Governmental Approvals.

Differing Site Condition shall mean: (1) subsurface or latent conditions which differ materially from those conditions indicated in the geotechnical reports included in *Exhibit D-Item 03*, at the actual boring holes as identified in such geotechnical reports; or (2) physical conditions of an unusual nature, differing materially from those ordinarily encountered in the area and generally recognized as inherent in the type of work provided for in the DB Agreement. The term shall specifically exclude all such conditions of which the DB Contractor had actual or constructive knowledge as of the Proposal Date. The foregoing definition specifically excludes (a) Utility facilities; (b) Hazardous Materials, including contaminated groundwater; (c) any conditions which constitute or are caused by a Force Majeure Event; and (d) discovery of Karst features.

Direct Costs shall mean the actual out-of-pocket costs incurred with respect to an item of Work, without any additional mark up, compensation percentage for overhead, profit or other indirect costs. Such term shall include applicable sales taxes, freight and delivery charges.

Directive Letter shall have the meaning set forth in *Section 14.1.1.2* of this DB Agreement.

Disadvantaged Business Enterprise or **DBE** shall have the meaning set forth in *Exhibit H* to this DB Agreement.

Disputes Board shall mean the disputes board established to assist in the resolution of disputes arising out of the Work, as detailed in *Section 25* of this DB Agreement.

Disputes Board Agreement shall have the meaning set forth in *Section 25.3.7* hereof.

Draw Request shall mean a Draw Request and Certificate in the form of *Exhibit L* to this DB Agreement.

Duct Bank shall have the meaning provided in *Technical Provision 18*.

Dust/Emission and Odor Control Plan shall mean the plan developed by the DB Contractor in accordance with *Technical Provision 26* that delineates how dust, emissions, and odor will be mitigated on the Project.

2. **Early Release-for-Construction** shall have the meaning provided in *Technical Provision*

Early Release for Construction Design Package shall have the meaning provided in *Technical Provision 2*.

Early Utility Adjustment shall mean Utility Adjustment work performed before issuance of NTP1 as described in *Technical Provision 8*.

Edwards Aquifer Recharge Zone shall mean the area where surface geology creates a potential for recharge of surface waters into the Edwards Aquifer. The recharge zone is identified as that area designated as such on official maps produced by TCEQ.

Edwards Aquifer Rules shall mean rules found in Title 30 Texas Administrative Code Chapter 213, which address activities that could pose a threat to water quality in the Edwards Aquifer, including wells and springs fed by the aquifer and water sources to the aquifer, including uplands areas draining directly to it and surface streams. The rules apply to regulated (e.g., construction-related and post-construction) activities and require an application be submitted to, and approved via letter by, the TCEQ for projects located within specific geographic areas identified as the Edwards Aquifer Recharge Zone, Edwards Aquifer Contributing Zone, and Edwards Aquifer Transition Zone.

Effective Date shall mean the date of this DB Agreement or such other date as shall be mutually agreed upon in writing by the Mobility Authority and the DB Contractor.

Engineering News Record Construction Cost Index shall mean the 12-month “Construction Cost Index” published by Engineering News-Record.

Environmental Approvals shall mean all Governmental Approvals arising from or required by any Environmental Law in connection with development of the Project.

Environmental Assessment (EA) shall mean the EA performed by TxDOT with respect to the Project.

Environmental Compliance Inspectors (ECIs) shall mean the person(s) who provide on-site monitoring of the Project under direction of the Environmental Compliance Manager as more particularly described in *Technical Provision 9*.

Environmental Compliance Manager (ECM) shall mean the person responsible for monitoring, documenting, and reporting environmental compliance for the Work as more particularly described in *Technical Provision 9*.

Environmental Documents (ED) shall mean the final versions of the following documents: (i) *Exhibit D-Item 2.1 – Environmental Assessment (EA)*; (ii) *Exhibit D-Item 2.2 – TxDOT Finding of No Significant Impact (FONSI)*; and the subsequent *Environmental Reevaluations of the EA/FONSI*.

Environmental Law shall mean any Law applicable to the Project or the Work regulating or imposing liability or standards of conduct that pertains to the environment, Hazardous Materials, contamination of any type whatsoever, or environmental health and safety matters, and any lawful requirements and standards that pertain to the environment, Hazardous Materials, contamination of any type whatsoever, or environmental health and safety matters, set forth in any permits, licenses, approvals, plans, rules, regulations or ordinances adopted, or other criteria and guidelines promulgated, pursuant to Laws applicable to the Project or the Work, as such have been or are amended, modified, or supplemented from time to time (including any present and future amendments thereto and reauthorizations thereof) including those relating to:

- (a) The manufacture, processing, use, distribution, existence, treatment, storage, disposal, generation, and transportation of Hazardous Materials;
- (b) Air, soil, surface and subsurface strata, stream sediments, surface water, and groundwater;
- (c) Releases of Hazardous Materials;
- (d) Protection of wildlife, Threatened or Endangered Species, sensitive species, wetlands, water courses and water bodies, historical, archeological, and paleontological resources, and natural resources;
- (e) The operation and closure of underground storage tanks;
- (f) The safety of employees and other persons; and
- (g) Notification, documentation, and record keeping requirements relating to the foregoing.

Without limiting the above, the term "Environmental Laws" shall also include the following:

- (i) The National Environmental Policy Act (42 U.S.C. §§ 4321 *et seq.*), as amended;
- (ii) The Comprehensive Environmental Response, Compensation, and Liability Act (42 U.S.C. §§ 9601 *et seq.*), as amended;
- (iii) The Solid Waste Disposal Act, as amended by the Resource Conservation and Recovery Act (42 U.S.C. §§ 6901 *et seq.*);
- (iv) The Emergency Planning and Community Right to Know Act of 1986 (42 U.S.C. §§ 11001 *et seq.*), as amended;
- (v) The Clean Air Act (42 U.S.C. §§ 7401 *et seq.*), as amended;

- (vi) The Federal Water Pollution Control Act, as amended by the Clean Water Act (33 U.S.C. §§ 1251 *et seq.*);
- (vii) The Resource Conservation and Recovery Act (42 U.S.C. §§ 6901, *et seq.*), as amended;
- (viii) The Toxic Substances Control Act (15 U.S.C. §§ 2601 *et seq.*), as amended;
- (ix) The Hazardous Materials Transportation Act (49 U.S.C. §§ 1801 *et seq.*), as amended;
- (x) The Oil Pollution Act (33 U.S.C. §§ 2701 *et seq.*), as amended;
- (xi) The Federal Insecticide, Fungicide and Rodenticide Act (7 U.S.C. §§ 136 *et seq.*), as amended;
- (xii) The Federal Safe Drinking Water Act (42 U.S.C. §§ 300 *et seq.*), as amended;
- (xiii) The Federal Radon and Indoor Air Quality Research Act (42 U.S.C. §§ 7401 *et seq.*), as amended;
- (xiv) The Occupational Safety and Health Act (29 U.S.C. §§ 651 *et seq.*);
- (xv) The Endangered Species Act (16 U.S.C. §§ 1531 *et seq.*), as amended;
- (xvi) The Fish and Wildlife Coordination Act (16 U.S.C. §§ 661 *et seq.*), as amended;
- (xvii) The National Historic Preservation Act (16 U.S.C. §§ 470 *et seq.*), as amended;
- (xviii) The Coastal Zone Management Act (33 U.S.C. §§ 1451 *et seq.*), as amended;
- (xix) The Texas Health and Safety Code, including Chapter 382 (the Clean Air Act), Chapter 383 (the Clean Air Financing Act), Chapter 361 (the Texas Solid Waste Disposal Act), Chapter 362 (the Solid Waste Resource Recovery Financing Act), Chapter 363 (the Municipal Solid Waste Act), Chapter 364 (the County Solid Waste Control Act), Chapter 370 (the Texas Toxic Chemical Release Reporting Act), Chapter 371 (the Texas Used Oil Collection, Management, and Recycling Act), Chapter 401 (the Texas Radioactive Materials and other Sources of Radiation Act), Chapter 402 (the Texas Low-Level Radioactive Waste Disposal Authority Act), Chapter

502 (the Texas Hazard Communication Act), Chapter 505 (the Texas Manufacturing Project Community Right-To-Know-Act), Chapter 506 (the Texas Public Employer Community Right-To-Know Act), and Chapter 507 (the Texas Non-manufacturing Facilities Community Right-To-Know-Act), and Chapter 711 (General Provisions Relating to Cemeteries);

- (xx) The Texas Natural Resources Code, including Chapter 40 (the Texas Oil Spill Prevention and Response Act of 1991);
- (xxi) The Texas Water Code;
- (xxii) The Texas Parks and Wildlife Code;
- (xxiii) The Texas Agriculture Code, including Chapter 76 (Pesticide and Herbicide Regulation) and Chapter 125 (the Agricultural Hazard Communication Act);
- (xxiv) The Texas Asbestos Health Protection Act (Chapter 1954, Texas Occupations Code);
- (xxv) The Surface Coal Mining and Reclamation Act (Chapter 134, Texas Natural Resources Act);
- (xxvi) The Texas Antiquities Code;
- (xxvii) Section 4(f) of the U.S. Department of Transportation Act (23 U.S.C. § 138, 49 U.S.C. § 303); and
- (xxviii) Section 6(f)(3) of the Land and Water Conservation Fund Act (16 U.S.C. § 4601-4).

Environmental Monitoring Program shall mean the program that the Environmental Compliance Manager supervises. The program includes monitoring field activities for environmental compliance by environmental inspectors, producing weekly reports, providing an environmental training program including a training staff, and developing an environmental team as more particularly described in *Technical Provision 9*.

Environmental Monitoring Reports (EMRs) shall mean the weekly reports prepared by the DB Contractor providing detailed information on development activities, species or resources monitored, and compliance / non-compliance issues as more particularly described in *Technical Provision 9*.

Environmental Protection Training Program shall mean that program to be initiated by the DB Contractor and overseen by Mobility Authority personnel to ensure the Work is conducted in accordance with the environmental commitments and requirements set forth in all Laws, rules,

regulations, and environmental approvals applicable to the Project as more particularly described in Technical Provision 9.

Environmental Reevaluation shall mean the process and resulting documentation to determine whether or not the EA and FONSI remain valid under circumstances listed in 43 TAC 2.85 and 23 CFR 771.129.

Environmental Team (ET) shall mean the personnel team appointed by the DB Contractor to ensure compliance with all Laws, rules, regulations, and environmental approvals applicable to the Project as more particularly described in Technical Provision 9.

Environmental Training Staff shall mean project personnel with appropriate experience appointed by the DB Contractor to develop and implement an Environmental Protection Training Program as more particularly described in Technical Provision 9.

Escrowed Proposal Documents or **EPDs** shall have the meaning set forth in Section 26.1 of this DB Agreement.

Event of Default shall have the meaning set forth in Section 17.2 of this DB Agreement.

Existing Utility Information shall mean the documents provided in Exhibit D - Item 4.

Existing Utility Property Interest shall mean any right, title or interest in real property (e.g., a fee or an easement) claimed by a Utility Owner as the source of its right to maintain an existing Utility in such real property, which is compensable in eminent domain.

Expendable Materials shall mean construction materials (e.g. wood, steel, concrete and re-bar) and equipment (e.g. shovels, power tools, office equipment or computers) that are completely incorporated into the Work or have no salvage value at completion of the Work.

Federal Requirements shall mean the provisions required to be part of federal-aid construction contracts, including the provisions set forth in Exhibit E to this DB Agreement.

Federal Utility Procedure List shall mean the list of applicable Utility Owners and other pertinent information as described in Technical Provision 18 that will be submitted to FHWA.

Final Acceptance or **Project Final Acceptance** or **Final Contract Acceptance** or **Final Construction Acceptance** shall mean the occurrence of all of the events and satisfaction of all of the conditions set forth in Section 20.3 of this DB Agreement for final acceptance of the Project.

Final As-Built Plans shall mean the final plans on which the DB Contractor shall have documented all changes made to the Final Design Package during the construction process. All field changes shall be documented and updated on the Final As-Built Plans set including changes from all RFI's.

Final Design shall mean, depending on the context: (a) the Final Design Plans, (b) the design concepts set forth in the Final Design Plans or (c) the process of development of the Final Design Plans.

Final Design Plans or **Final Design Documents** or **Final Design Package** shall mean the complete design package of Plans and supporting documentation addressing all constructability, DQC, DQA, Mobility Authority, TxDOT, FHWA or other agency reviews and comments in accordance with the Contract Documents. The Final Design Package represents a complete package for the Project corridor or a pre-established section of the Project with defined Project station limits.

Final Design Submittal shall have the meaning set forth in *Technical Provision 2*.

Final Draw Request shall mean the written request for Final Payment under the DB Agreement as described in *Section 13.6* of this DB Agreement.

Final Payment shall mean payment by Mobility Authority of the final installment of the DB Price, as modified in accordance with the terms of this DB Agreement.

Final ROW shall mean the Schematic ROW and the Additional Properties, but excluding therefrom any portion of the Schematic ROW eliminated from the Project by a Change Order.

Final Utility Information shall have the meaning set forth in the definition of “**Cost Differential**” as set forth in this Exhibit A.

Final Warranty Acceptance shall have the meaning set forth in *Technical Provision 3*.

Finance Closing Date shall mean the date on which all of the following have occurred (i) adoption of the Mobility Authority Board resolution authorizing the Indenture securing the Bonds; (ii) the Bonds have been issued, sold, and delivered to investors in accordance with the terms of the Project Finance Documents and the initial funds for performance of the Work have been released thereunder; (iii) adoption of the TxDOT Minute Order authorizing TxDOT funding for the Project; (iv) approval of funding for the Project from CAMPO; and (v) all other capital and funds required for payment of the Work and the DB Price for the Project shall have been contractually obligated.

Finding of No Significant Impact (FONSI) shall mean the FONSI issued by TxDOT with respect to the Project.

Fiscal Year shall mean the calendar year or any other consecutive 12-month period selected by the DB Contractor and approved by the Mobility Authority.

Float shall mean generally the difference between early completion times and late completion times for activities as shown on the Project Schedule, and shall include any float contained within an activity as well as any period containing an artificial activity (that is, one

which is not encompassed within the meaning of Work), as more particularly described in Section 5.6 of this DB Agreement.

Force Majeure Event shall mean any of the events listed in clause (a) through (k) below, subject to the exclusions listed in clauses (i) through (ix) below, which materially and adversely affects the DB Contractor's obligations, provided such events are beyond the control of members of the DB Contractor Group and are not due to an act, omission, negligence, recklessness, willful misconduct, breach of contract or Law of any member of the DB Contractor Group, and further provided that such events (or the effects of such events) could not have been avoided by the exercise of caution, due diligence, or reasonable efforts by the DB Contractor:

- (a) Any earthquake, tornado, hurricane or other natural disaster in the vicinity of and directly affecting the Project;
- (b) Any epidemic, blockade, rebellion, war, riot, act of sabotage or civil commotion in the vicinity of and directly affecting the Project;
- (c) The discovery at, near or on the Final ROW (excluding DB Contractor-Designated ROW) of any archaeological, paleontological or cultural resources provided that the existence of such resources or substances was not disclosed in, or ascertainable from, the RFDP Documents, was not otherwise known to the DB Contractor prior to the Proposal Date and would not have become known to the DB Contractor by undertaking reasonable investigation prior to the Proposal Date, and excluding any risks of delays arising from such discovery allocated to the DB Contractor in Section 14.10.1 of this DB Agreement;
- (d) The discovery at, near or on the Final ROW of any species listed as threatened or endangered under the federal or State endangered species act (regardless of whether the species is listed as threatened or endangered as of the Proposal Date);
- (e) Any Change in Law, which results in an increase in the DB Contractor's costs of at least \$150,000 as a result of (1) a material modification of the Project design, (2) a new major State or federal environmental approval not previously required for the Project, or (3) a law that specifically targets the Project or the DB Contractor;
- (f) Any Release of Hazardous Material by a third party who is not a member of the DB Contractor Group which occurs after the Proposal Date and is required to be reported to a Governmental Entity and which renders use of the roadway or construction area unsafe absent assessment, containment and/or remediation;
- (g) Issuance of a temporary restraining order or other form of injunction by a court that prohibits prosecution of a material portion of the Work, except to the extent arising out of, related to or caused by, the delay, act, omission, negligence, willful misconduct, recklessness or breach of contract or Law by any member of the DB Contractor Group;

- (h) The suspension, termination, interruption, modification, denial or failure to obtain or non-renewal of any Mobility Authority-Provided Approval, except to the extent that such suspension, termination, interruption, modification, denial or failure to obtain or non-renewal arises from any modification by the DB Contractor in the Final Design from the original design concept included in the Environmental Documents;
- (i) [RESERVED]
- (j) The discovery during bridge widening on the Project of an unknown condition, not described in TxDOT's condition survey of Project bridges, which exists in a currently existing bridge that requires the expenditure by the DB Contractor of more than \$50,000 per bridge to correct above and beyond any amounts that are otherwise necessary as part of the DB Contractor's normally expected Work related to bridge widening; and
- (k) Issuance of a Homeland Security Advisory System (HSAS) threat level Severe (Red) or issuance of a rule, order or directive from the U.S. Department of Homeland Security or any Governmental Entity regarding specific, material environmental or security threats to the Project or the region in which the Project is located, to the extent such rule, order or directive requires specific material changes in the DB Contractor's normal design, construction, operation or maintenance procedures in order to comply.

The term “**Force Majeure Event**” shall be limited to the matters listed above and specifically excludes from its definition the following matters which might otherwise be considered a force majeure event:

- (i) any fire or other physical destruction or damage, or delays to the Project which occur by action of the elements, including lightning, explosion, drought, rain, flood, snow, storm, except as specified in *clause (a)* above;
- (ii) except as provided in *clause (b)* above, malicious or other acts intended to cause loss or damage or other similar occurrence, including vandalism or theft;
- (iii) any strike, labor dispute, work slowdown, work stoppage, secondary boycott, walkout or other similar occurrence;
- (iv) the suspension, termination, interruption, denial, failure to obtain, non-renewal or change in any requirements of any Governmental Approval, except for any such matter falling within the scope of clause (e), (f) or (h) above;
- (v) any increased costs or delays related to any Utility Adjustment Work or railroad work or failure to obtain any approval, work or other action from a

Utility Owner or railroad, except to the extent directly due to any of the matters listed in clause (a) through (j) above;

- (vi) the presence at, near or on the Site, as of the Effective Date, of any Hazardous Material, including substances disclosed in the Reference Documents;
- (vii) any Change in Law which has the effect of modifying a Utility Owner's required specifications, standards of practice and/or construction methods for the Utility Adjustment Work to be furnished or performed by the DB Contractor (or reimbursed by the DB Contractor), which occurs after the Proposal Date but prior to the date on which the applicable Utility Adjustment Agreement is signed by the Utility Owner;
- (viii) the virus known as severe acute respiratory syndrome coronavirus 2 (SARS-CoV-2) and the disease known as COVID-19, including any disruptions to, and delays or interruptions in, development of the Project in accordance with the DB Agreement and any approved Baseline Schedule, as also including impacts of the aforementioned virus or disease on workforce, supply chain, and availability of equipment or materials; and
- (ix) any matters not caused by the Mobility Authority or beyond the control of the Mobility Authority and not listed in clause (a) through (j) above.

Formal Consultation (Section 7) shall mean the process under Section 7 of the ESA required when a project may affect or is likely to affect a Threatened or Endangered Species, in which a Federal agency (or its proxy) and the USFWS share information about the proposed project and the species likely to be affected, after which the USFWS will prepare a biological opinion on whether the proposed activity will jeopardize the continued existence of a listed species.

Formal Design Review shall mean Plan reviews required in the process of developing the Final Design Package:

- (i) Preliminary (30%) Design Submittal: Schematic plans modified to reflect the final plan format with the DB Contractor suggested revisions.
- (ii) Intermediate (65%) Design Submittal: Shall have the meaning set forth in *Technical Provision 2*.
- (iii) Final (100%) Design Submittal: Plans completed to reflect all improvements sufficiently to allow construction to be completed.

Generally Accepted Accounting Principles or **GAAP** shall mean such accepted accounting practice as, in the opinion of the accountant, conforms at the time to a body of generally accepted accounting principles.

General Engineering Consultant (GEC) shall mean WSP, or any other entity designated in writing by the Mobility Authority to serve as its GEC, together with any subconsultants to WSP.

Geologist shall mean the team member designated by the Environmental Compliance Manager to provide expertise on monitoring impacts on voids, caves and karst features due to construction activities related to the Design-Build Work as more particularly described in *Technical Provision 9*.

Geotechnical Engineering Reports shall mean the reports which meet the requirements described in the *Technical Provision 14*.

Governmental Approval shall mean any permit, license, consent, authorization, waiver, variance or other approval, guidance, mitigation agreement, or memoranda of agreement/understanding, and any amendment or modification of any of them provided by Governmental Entities including State or federal regulatory agencies, agents, or employees, which authorize Work, but excluding any such approvals given by or required from any Governmental Entity in its capacity as a Utility Owner or railroad owner.

Governmental Entity shall mean any federal, State or local government and any political subdivision or any governmental, quasi-governmental, judicial, public or statutory instrumentality, administrative agency, authority, body or entity other than the Mobility Authority.

Green Credit(s) shall mean the credits awarded to the DB Contractor for completion of Mandatory Sustainable Initiatives and Optional Sustainable Initiatives as more fully described in *Technical Provision 26*.

Guarantor shall mean each of the entities which provided a guarantee in the form of some or all of the obligations of the DB Contractor under this DB Agreement.

Hazardous Materials shall mean any element, chemical, compound, material or substance, whether solid, liquid or gaseous, which at any time is defined, listed, classified or otherwise regulated in any way under any Environmental Laws, or any other such substances or conditions (including mold and other mycotoxins or fungi) which may create any unsafe or hazardous condition or pose any threat to human health and safety. The term "**Hazardous Materials**" includes the following:

- (a) Hazardous wastes, hazardous material, hazardous substances, hazardous constituents, and toxic substances or related materials, whether solid, liquid, or gas, including substances defined as or included in the definition of "hazardous substance", "hazardous waste", "hazardous material", "extremely hazardous waste", "acutely hazardous waste", "radioactive waste", "radioactive materials", "bio-hazardous waste", "pollutant", "toxic pollutant", "contaminant", "restricted hazardous waste", "infectious waste", "toxic substance", "toxic waste", "toxic material", or any other term or expression intended to define, list or classify substances by reason of properties harmful to health, safety or the indoor or outdoor

environment (including harmful properties such as ignitability, corrosivity, reactivity, carcinogenicity, toxicity, reproductive toxicity, "TCLP toxicity" or "EP toxicity" or words of similar import under any applicable Environmental Laws);

- (b) Any petroleum, including crude oil and any fraction thereof, and including any refined petroleum product or any additive thereto or fraction thereof or other petroleum derived substance; and any waste oil or waste petroleum byproduct or fraction thereof or additive thereto;
- (c) Any drilling fluids, produced waters and other wastes associated with the exploration, development or production of crude oil, natural gas or geothermal resources;
- (d) Any flammable substances or explosives;
- (e) Any radioactive materials;
- (f) Any asbestos or asbestos-containing materials;
- (g) Any lead and lead-based paint;
- (h) Any radon or radon gas;
- (i) Any methane gas or similar gaseous materials;
- (j) Any urea formaldehyde foam insulation;
- (k) Electrical equipment which contains any oil or dielectric fluid containing regulated levels of polychlorinated biphenyls;
- (l) Pesticides;
- (m) Any other chemical material or substance, exposure to which is prohibited, limited or regulated by any Governmental Entity or which may or could pose a hazard to the health and safety of the owners, operators, users or any Persons in the vicinity of the Project or to the indoor or outdoor environment; and
- (n) Soil, or surface water or ground water, contaminated with Hazardous Materials as defined above.

Hazardous Materials Delay shall have the meaning set forth in Section 14.8.3 of this DB Agreement.

Hazardous Materials Management shall mean sampling, stock-piling, storage, backfilling in place, asphalt batching, recycling, treatment, clean-up, remediation, transportation

and/or off-site disposal of Hazardous Materials, whichever is the most cost-effective approach authorized under applicable Law.

Hazardous Materials Management Plan shall have the meaning set forth in *Technical Provision 9*.

Hazardous Materials Manager shall mean the person designated by the Environmental Compliance Manager to provide expertise in the safe handling of Hazardous Materials in accordance with *Technical Provision 9*.

Identified Utility shall mean any Utility impacted by the Project to which any one or more of the following applies:

- (a) Its owner is accurately stated on the Existing Utility Information, and, as determined by the Mobility Authority, the location and extent of such Utility as shown on the Existing Utility Information (whether as existing or proposed) is a reasonable representation of the location and extent of such Utility, given the quality level of investigation performed in developing the Existing Utility Information;
- (b) Its type (e.g., gas, water, electric) is accurately stated on the Existing Utility Information (differences in material, e.g., clay vs. plastic, shall not be considered a difference in type), and, as determined by the Mobility Authority, the location and extent of such Utility as shown on the Existing Utility Information (whether as existing or proposed) is a reasonable representation of the location and extent of such Utility, given the quality level of investigation performed in developing the Existing Utility Information;
- (c) It is an overhead Utility existing as of the Proposal Date or which commenced installation prior to the Proposal Date;
- (d) A surface inspection of the area in which the Utility is located on the Proposal Date would have shown the Utility's existence or the likelihood of its existence by reason of above-ground facilities such as buildings, meters, manholes or markers; provided, however, that if the DB Contractor has not been granted access to the parcel on which a Utility is located prior to the Proposal Date, then for purposes of determining whether a surface inspection would have shown the Utility's existence or likelihood of its existence, such surface inspection shall be deemed to have been made from the nearest parcel to which the DB Contractor has been granted access prior to the Proposal Date, or from the nearest public right of way, whichever is closer; or
- (e) It is located in the same trench as an Identified Utility, and is of the same type or ownership as the Identified Utility.

If a Utility falls within any of the categories listed in clauses (a) through (e) above, then it is an Identified Utility regardless of any discrepancy between (i) the information provided on the Existing Utility Information, and (ii) the actual characteristics of that Utility with respect to its

size, its horizontal or vertical location, its ownership, its type, or any other characteristic. Without limiting the generality of the foregoing, if a Utility is shown on the Existing Utility Information as being on public right of way, and it is in fact located on private right of way, or vice versa, that discrepancy is of no relevance in determining whether or not that Utility is an Identified Utility.

Impacted Soil Material shall mean areas within closed or abandoned landfills that contain buried solid waste material interspersed throughout the soil profile. The Impacted Soil Material can be disposed of in Type I or Type IV landfills, depending on waste characterization. Impacted Soil Material includes the entire soil profile through which the buried solid waste is interspersed. This term specifically excludes any types of Hazardous Material, other than the solid waste described above, encountered within the Impacted Soil Material. Any other types of Hazardous Material are considered to be Unknown Hazardous Materials as stated in *Technical Provision 9* and *Exhibit D – Item 1q – Hazardous Materials Monitoring and Mitigation Plan*.

Incentive Payment shall have the meaning set forth in *Section 13.4* of this DB Agreement.

Incidental Utility Adjustment Work shall mean all of the following that is necessary or determined by the DB Contractor to be required for the construction and/or accommodation of the Project:

- (a) service line relocation/adjustments including appurtenances whether or not shown as an Identified Utility;
- (b) temporary relocation/adjustments;
- (c) Utility appurtenance adjustments;
- (d) protections-in-place; and,
- (e) all surface restoration work including resurfacing pavements and sidewalks, reconstruction of curbs and gutters, restriping, and landscaping where necessary due to Utility Adjustment Work.

Indemnified Parties shall mean the Mobility Authority, TxDOT, the State and their respective successors, assigns, officeholders, officers, directors, agents, representatives, consultants and employees (including the Resident Engineer).

Indenture shall mean the indenture of trust or similar trust and security agreement entered into between the Mobility Authority and the Bond Trustee pursuant to which the Bonds are issued, and any authorized amendment or supplement thereto.

Initial Site Assessment shall mean a process that is very similar to the Phase I ESA process, with the primary difference being that the ISA typically covers multiple parcels of land for a project corridor, as opposed to the single parcel or business development typical for an ASTM Phase I ESA.

Instructions to Proposers shall mean the Instructions to Proposers issued by the Mobility Authority in final form on May 14, 2020 as part of the RFDP with respect to the Project, including all attachments thereto and any subsequent addenda.

Intelligent Transportation System (ITS) shall have the meaning set forth in *Technical Provision 18*.

Intermediate (65%) Design Submittal shall have the meaning set forth in *Technical Provision 2*.

Investigative Work Plan (IWP) shall mean a plan prepared by the DB Contractor addressing the methods, techniques, and analytical testing requirements to adequately characterize the extent of impacts by Hazardous Materials to an area of concern as more particularly described in *Technical Provision 9*.

Karst Plan Delay shall have the meaning set forth in *Section 14.18.3* of this DB Agreement.

Karst Mitigation Delay shall have the meaning set forth in *Section 14.18.3* of this DB Agreement.

Key Personnel shall mean those individuals and DB Contractor personnel (Category A and B) identified in *Technical Provision 1*.

Law or **Laws** shall mean any statute, law, regulation, ordinance, rule, judgment, order, decree, permit, concession, grant, franchise, license, agreement, directive, guideline, policy requirement or other governmental restriction or any similar form of decision of or determination by, or any interpretation or administration of any of the foregoing by, any Governmental Entity, which is applicable to the Project, the Final ROW, and/or the Work, whether now or hereafter in effect, including Environmental Laws.

Leaking Petroleum Storage Tank shall mean a tank installed underground to store petroleum fuel product, from which a release of fuel product has occurred potentially contaminating surrounding soil, groundwater, or surface waters, or affecting indoor air spaces.

Licensed Professional Geoscientist shall mean an individual who has been duly licensed by the Texas Board of Professional Geoscientists to engage in the public practice of geoscience in the State of Texas.

Lien shall mean any pledge, lien, security interest, mortgage, deed of trust or other charge or encumbrance of any kind, or any other type of preferential arrangement (including any agreement to give any of the foregoing, any conditional sale or other title retention agreement, any lease in the nature of a security instrument and the filing of or agreement to file any financing statement under the Uniform Commercial Code of any jurisdiction).

Liquidated Damages shall have the meaning set forth in *Section 18.1* of this DB Agreement.

Losses shall mean any loss, damage (including personal injury, property damage and natural resource damages), injury, liability, cost, expense (including attorneys' fees and expenses (including those incurred in connection with the enforcement of any provision of this DB Agreement)), fee, charge, demand, investigation, proceeding, action, suit, claim, judgment, penalty, fine or Third Party Claims.

Major Change Order shall mean a Change Order that requires prior FHWA approval to be eligible for federal participation, including a Change Order that (i) reduces the geometric design or structural capacity below Project design criteria, (ii) increases the DB Price by \$300,000 or more, (iii) changes the limits of the Project; (iv) changes the Traffic Control Plan in such a way as to reduce capacity for through traffic or cross streets, (v) involves the settlement of a dispute, and/or (vi) changes the access on the controlled access portion of the Project.

Major Participant shall mean each entity with: (a) primary responsibility for design; (b) primary responsibility for the Design Quality Control (DQC); (c) primary responsibility for the construction; (d) primary responsibility for the Construction Quality Control (CQC) and/or Materials Quality Assurance Testing; (e) a direct equity interest in the Proposer (whether as a member, partner, shareholder or otherwise); or (f) a proposed subcontract with a value greater than or equal to \$5,000,000. Notwithstanding the foregoing, if the Proposer is a publicly traded company, shareholders owning less than 10% of the outstanding stock shall not be considered Major Participants.

Major Subcontracts shall mean a Subcontract in excess of \$5,000,000.

Mandatory Sustainable Initiative shall mean an activity that the DB Contractor is required to complete in accordance with *Technical Provision 26* with the goal of achieving a more environmentally sustainable Project.

Master Utility Adjustment Agreement shall mean an agreement with a particular Utility Owner in the format provided in *Exhibit D-Item 4* that specifies the delegation of Utility Adjustment cost and work responsibility between the DB Contractor and the Utility Owner. See Also "Utility Adjustment Agreement."

Material Acceptance shall have the meaning set forth in *Technical Provision 2*.

Materials Acceptance Testing (MAT) shall have the meaning provided in *Technical Provision 2*.

Materials on Hand means non-perishable materials that do not have a shelf life or characteristics that would materially change when exposed to the elements, and that have been sample tested approved and certified and are ready for incorporation into the Work. Such materials include structural steel, reinforcing steel, pre-cast concrete elements, and illumination poles, or

other non-perishable materials at Mobility Authority discretion. Materials that would not be considered Materials on Hand include cement, fine aggregate, and fill.

Materials Quality Acceptance Firm (MQAF) shall have the meaning provided in *Technical Provision 2*.

Materials Quality Acceptance Manager (MQAM) shall have the meaning provided in *Technical Provision 2*.

Materials Quality Acceptance Testing (MQAT) shall have the meaning provided in *Technical Provision 2*.

Mitigation Plan shall mean the plan prepared by the DB Contractor detailing the mitigation requirements contained in the Governmental Approvals and Mobility Authority-Provided Approvals.

Mitigation Site shall mean any real property (which term is inclusive of all estates and interests in real property), improvements and fixtures outside of the Schematic ROW that will be acquired to mitigate the Project's environmental effects pursuant to the requirements set forth in *Technical Provision 9*, and pursuant to *Sections 3 and 17* of this DB Agreement. The term specifically includes any air space, surface rights and subsurface rights within the Mitigation Site that the Mobility Authority directs the DB Contractor to acquire for the Project.

Mobility Authority shall mean the Central Texas Regional Mobility Authority, and any entity succeeding to the powers, authorities and responsibilities of the Mobility Authority invoked by or under the Contract Documents. References herein to Mobility Authority with respect to certain approvals and the exercise of certain authority shall include Mobility Authority's duly appointed designees.

Mobility Authority-Caused Delays shall mean unavoidable delays arising from the following matters and no others, but only to the extent that they (i) materially adversely affect a Critical Path, (ii) are not mitigated or susceptible of handling by a work around, and (iii) are not due to an act, omission, negligence, recklessness, willful misconduct, breach of contract or violation of Law of or by any member of the DB Contractor Group:

- (a) Mobility Authority-Directed Changes;
- (b) Failure or inability of the Mobility Authority to make the DB Contractor Designated ROW available on or before 240 Days following Mobility Authority or TxDOT approval of the condemnation packet in accordance with Section 6.5 of this DB Agreement;
- (c) Failure or inability of the Mobility Authority to make Schematic ROW available for construction within the time frame specified in *Section 6.6* of this DB Agreement;

- (d) Failure or inability of the Mobility Authority to provide responses to proposed schedules, plans, Design Documents, condemnation and acquisition packages, and other submittals and matters for which response is required, within the time periods (if any) indicated in the Contract Documents, or other failure of Mobility Authority to act within a reasonable time period with respect to actions which it is required to take under this DB Agreement, following delivery of written notice from the DB Contractor requesting such action in accordance with the terms and requirements of this DB Agreement;
- (e) Uncovering, removing and restoring Work pursuant to Section 7.3.3 of this DB Agreement if such Work exposed or examined is in conformance with the requirements of the Contract Documents, the Governmental Approvals and applicable Law, unless such conforming Work was performed or materials used without adequate notice to and opportunity for prior inspection by the Mobility Authority.
- (f) Failure or inability of the Mobility Authority to provide New Environmental Approvals to the extent that such New Environmental Approvals are necessitated by a Mobility Authority-Directed Change.
- (g) Failure or inability of the Mobility Authority to issue NTP2 within 90 Days of the date of issuance of NTP1 in accordance with Section 13.2.2.3 of this DB Agreement.
- (h) Subject to the notice requirements of Section 27.4.2 of this DB Agreement, any action or inaction on the part of the System Integrator that causes a delay to the DB Contractor.

Any suspension of Work arising from litigation shall not be considered a Mobility Authority-Caused Delay (although it may qualify as a Force Majeure Event under clause (g) of the definition of “**Force Majeure Event**”) despite the fact that Mobility Authority may specifically direct the DB Contractor to suspend the Work.

Mobility Authority-Directed Changes shall mean any changes in the scope of the Work or terms and conditions of the Contract Documents (including changes in the standards applicable to the Work) that increase or decrease the DB Contractor’s costs by more than \$50,000, which the Mobility Authority has directed the DB Contractor to perform as described in Section 14 of this DB Agreement. In no event shall the DB Contractor’s responsibility for Mobility Authority-Directed Changes involving less than \$50,000 in additional costs or involving a delay to a Critical Path exceed an aggregate amount of \$300,000.

Mobility Authority Director of Engineering shall mean the person designated by the Mobility Authority to serve in such capacity for the Project.

Mobility Authority-Provided Approvals shall mean the following:

- (a) the EA and FONSI;
- (b) approvals under the National Historic Preservation Act (16 U.S.C. §470(f)) and implementing regulations (36 C.F.R §§800, et seq.) to the extent the Mobility Authority has agreed to be responsible therefor; and
- (c) any other Mobility Authority provided Governmental Approval set forth in Technical Provision 9.

Monthly Updates shall mean the monthly updates to the Project Schedule, as more fully described in Technical Provision 5.

MOT Diary shall have the meaning set forth in Technical Provision 22.4.3.2.

MOT Task Force shall mean representatives of the the DB Contractor, the Mobility Authority, TxDOT, municipal and county representatives having jurisdiction over the Project, law enforcement agencies, emergency response providers, all affected stakeholders, and other agencies.

Natural Resource Biologist shall mean the team member designated by the Environmental Compliance Manager to provide expertise on monitoring impacts on wildlife and the natural environment due to construction activities related to the Work as more particularly described in Technical Provision 9.

New Environmental Approval shall mean (a) any Environmental Approval required for the Project, other than Mobility Authority-Provided Approvals, and (b) any revision, modification, or amendment to any Mobility Authority-Provided Approval.

New Utility Property Interest shall mean any permanent right, title or interest in real property outside of the Final ROW (e.g., a fee or an easement) which is acquired for a Utility being reinstalled in a new location as a part of the Utility Adjustment Work. The term specifically excludes any statutory right of occupancy or permit granted by a Governmental Entity for occupancy of its real property by a Utility.

Noise Mitigation Plan shall mean the plan developed by the DB Contractor in accordance with Technical Provision 26 to address how to mitigate construction noise.

Nonconforming Work shall mean Work that does not conform to the requirements of the Contract Documents, Governmental Approvals, applicable Law or the Design Documents.

Notice of Intent (NOI) shall mean the notice of intent prepared and submitted by the DB Contractor to the TCEQ under the Construction General Permit for storm water discharges from construction sites.

Notice of Termination shall mean a notice issued by the Mobility Authority to terminate all or a portion of this DB Agreement and the performance of the Work by the DB Contractor pursuant to Section 16.3 of this DB Agreement.

Notice to Proceed (NTP) shall mean a written notice issued by the Mobility Authority to the DB Contractor authorizing the DB Contractor to proceed with Work.

NTP1 Work shall mean certain design work and Utility Adjustment work, not to exceed an aggregate of \$23,724,604, to be performed following issuance of NTP1 as more fully described in Exhibit B – Scope of Work.

Operational Testing Deadline shall have the meaning set forth in Section 18.1.2 of this DB Agreement.

Optional Sustainable Initiative shall mean an activity that the DB Contractor chooses to perform to achieve Green Credits. These activities are described in Technical Provision 26.

Owner Managed Utility Adjustment Agreement shall mean a Utility Adjustment Agreement providing for construction by the Utility Owner of the Utility Adjustment(s) addressed therein.

Party shall mean the DB Contractor or the Mobility Authority, as the context may require, and “**Parties**” shall mean the DB Contractor and the Mobility Authority, collectively.

Payment Activity shall mean a Schedule Activity that represents Work that is included in the DB Price and has been cost-loaded in accordance with Section 5.2.2, of the Technical Provision 5, as well as Mobilization payment, as described in Section 12.3.4.1 of this DB Agreement.

Payment Bond shall have the meaning set forth in Section 9.3 of this DB Agreement, the form of which is attached to this DB Agreement as Exhibit J.

Payment Curve shall mean the Payment Curve set forth in Exhibit G, which constitutes the aggregate amount of payments which may be made to the DB Contractor hereunder at any specified time.

PCO Notice shall mean a notice delivered by the DB Contractor to the Mobility Authority, in strict accordance with the provisions of Section 14.3.2.3 of this DB Agreement for the purpose of informing the Mobility Authority of a potential change to the Work.

Performance Bond shall have the meaning set forth in Section 9.2 of this DB Agreement, the form of which is attached to this DB Agreement as Exhibit I.

Person shall mean any individual, corporation, joint venture, limited liability company, company, voluntary association, partnership, trust, unincorporated organization or Governmental Entity.

Phase I Environmental Site Assessment shall mean a review of records, a site inspection, and interviews with owners, occupants, neighbors and local government officials for a potentially contaminated property by an environmental professional trained in the appropriate standards.

Phase II Sampling shall mean the sampling and laboratory analysis necessary to confirm the presence of hazardous materials as part of a Phase II ESA. This sampling may include: surface soil and water samples; subsurface soil borings; groundwater monitoring; drum sampling; dry well, floor drain and catch basin sampling; transformer/capacitor sampling; geophysical testing for buried tanks and drums; or underground storage tank testing.

Plans shall mean approved contract drawings, working drawings, supplemental drawings, detail sheets or exact reproductions thereof, which show the location, character, dimensions and details of the Work to be done.

Preliminary (30%) Design Submittal shall have the meaning set forth in *Technical Provision 2*.

Preventive Action shall mean the cleanup, removal, or stabilization of Hazardous Materials-contaminated soil or groundwater required to facilitate construction of the Project.

Private Pipeline means a private line, facility or system used for the carriage, transmission and/or distribution of gas, oil, petroleum products, hydrocarbons, and similar substances, which is used for the benefit of one or more individual recipients rather than directly or indirectly serving the public.

Professional Engineer shall mean an individual who holds a license as a Professional Engineer issued by the Texas Board of Professional Engineers.

Professional Geoscientist shall mean an individual who holds a license as a Professional Geoscientist issued by the Texas Board of Professional Geoscientists.

Programmatic Agreement (PA) shall mean a cooperative agreement between the FHWA, TxDOT, Advisory Council on Historical Preservation (ACHP) and Texas Historical Commission (THC) which addresses the responsibilities for coordination and communication between agencies for the conservation of cultural resources in regards to State and federal transportation projects.

Project shall have the meaning set forth in the first Recital to this DB Agreement.

Project Baseline Schedule (PBS-2) shall mean the schedule consistent with the completion deadlines, submitted by the DB Contractor for approval, setting forth the approved schedule of Work against which any subsequent schedule amendments are tracked, as more particularly described in *Technical Provision 5*.

Project Design shall mean the design developed by the DB Contractor for the facility to be constructed by the DB Contractor in accordance with such design, meeting at least the minimum requirements of the Contract Documents.

Project Development Agreement (PDA) shall mean the Project Development Agreement between TxDOT and the Mobility Authority with respect to the Project.

Project Finance Documents shall mean those documents, including trust agreements, to be entered into by the Mobility Authority to secure or evidence the Bonds and the other obligations to be issued or entered into for the purpose of financing the Project.

Project Management Plan shall have the meaning set forth in *Technical Provision 1*.

Project Manager shall mean the individual designated by the DB Contractor and approved in writing by the Mobility Authority who will be in the position to take full responsibility for the prosecution of the Work and who will act as a single point of contact on all matters on behalf of the DB Contractor, pursuant to *Section 3.6.3* of this DB Agreement.

Project Specific Location shall mean a material source, waste site, parking area, storage area, field office, staging area, haul road, or other accessory site associated with the construction of a transportation project.

Project Schedule shall mean the original schedule submitted with the Proposal, (the preliminary Project Baseline Schedule (PBS-1)), the accepted Project Baseline Schedule (PBS-2), the accepted Project Baseline Schedule (PBS-3), or the most recently accepted PBS (PBS-4, PBS-5, etc.) incorporating changes submitted in an accepted Revised PBS .

Project Status Schedule Update shall have the meaning set forth in *Technical Provision 5*.

Proposal shall mean the Proposal submitted by the DB Contractor to the Mobility Authority on August 18, 2020 in response to the RFDP issued by the Mobility Authority in final form on July 1, 2020.

Proposal Bond shall mean the proposal bond provided by the DB Contractor on the Proposal Date as required by the RFDP Documents.

Proposal Date or Proposal Due Date shall mean August 18, 2020.

Proposer shall mean each entity that was shortlisted based on the Mobility Authority's evaluation of submissions in response to the Request for Qualifications for the Project.

Protected Species shall mean animal or plant species listed by the U.S. Fish and Wildlife Service or Texas Parks and Wildlife Department ("TPWD") as Threatened or Endangered Species, or listed by TPWD as Species of Greatest Conservation Need.

Protection in Place or **protection in place** shall mean any action taken to avoid damaging a Utility which does not involve removing or relocating that Utility, including staking the location of a Utility, exposing the Utility, avoidance of a Utility's location by construction equipment, installing steel plating or concrete slabs, encasement in concrete, temporarily de-energizing power

lines, and installing physical barriers. The term includes both temporary measures and permanent installations meeting the foregoing definition.

Public Information Act shall mean the Texas Government Code Chapter 552.001 *et seq.*

Punch List shall mean the list of Work which remains to be completed after Substantial Completion has been achieved and before Final Acceptance, and shall be limited to items of the Work that are necessary to correct minor imperfections and deviations from the requirements of the Contract Documents, Governmental Approvals, applicable Law and Design Documents, but which have no material or adverse effect on the use, safety or operability of the Project.

Quality Assurance Program (QAP) shall have the meaning set forth in *Technical Provision 2*.

Quitclaim Deed shall mean a quitclaim deed to be executed by a Utility Owner relinquishing its rights to maintain a Utility in a particular location, as more particularly described in *Technical Provision 8*.

Recognized Environmental Condition shall mean the presence or likely presence of any hazardous substances or petroleum products in, on, or at a property: (1) due to any release to the environment; (2) under conditions indicative of a release to the environment; or (3) under conditions that pose a material threat of a future release to the environment.

Record Drawings. See “As Built Documents.”

Recovery Schedule shall mean the schedule the DB Contractor is required to provide under *Section 5.5* of this DB Agreement.

Reference Documents shall mean those documents listed in *Exhibit D* of this DB Agreement. The Reference Documents are not considered Contract Documents, except to the extent portions may be incorporated into the Contract Documents by a specific reference, and were provided to the DB Contractor for informational purposes only and without representation or warranty by the Mobility Authority.

Referenced Standard shall mean any standard applicable to the Project established by reference contained in the Contract Documents to a described publication.

Registered Professional Engineer shall mean a person who has been duly licensed and registered by the Texas State Board of Registration for Professional Engineers to engage in the practice of engineering in the State.

Reimbursable Hazardous Materials Costs shall mean the DB Contractor’s actual costs of performance of Hazardous Materials Management, determined in accordance with *Section 14.8* of this DB Agreement.

Reimbursable Karst Features Costs shall have the meaning set forth in Section 14.18.2 of this DB Agreement.

Release of Hazardous Materials shall mean any spill, leak, emission, release, discharge, injection, escape, leaching, dumping or disposal of Hazardous Materials into the soil, air, water, groundwater or environment, including any exacerbation of an existing release or condition of Hazardous Materials contamination.

Released-for-Construction Plans shall have the meaning provided in Technical Provision 2.

Remedial Action Plan shall mean a plan that specifies the measures needed to implement the cleanup of contaminated soil, fill and/or fluids from a site in which hazardous materials have been confirmed.

Replacement Utility Property Interest shall mean any right, title or interest in real property (e.g., a fee or an easement) required by a Utility Owner to replace an Existing Utility Property Interest as a result of Adjustment due to the Project.

Request for Change Order Resolution Meeting shall mean the notice by the DB Contractor delivered to the Mobility Authority requesting that the Mobility Authority schedule a meeting to discuss a particular event or situation that qualifies as an Eligible Change in accordance with Section 14.3.1.2 of this DB Agreement, as more particularly described in Section 14.3.2.2 of this DB Agreement.

Request for Change Proposal shall mean a written notice issued by the Mobility Authority to the DB Contractor under Section 14.2.1 of this DB Agreement, advising the DB Contractor that the Mobility Authority may issue a Mobility Authority-Directed Change or wishes to evaluate whether to initiate such a change pursuant to Section 14.2.1 of this DB Agreement.

Request for Detailed Proposals or **RFDP** shall mean the Request for Detailed Proposals issued by the Mobility Authority in final form on July 1, 2020 with respect to the Project, including all attachments thereto and any subsequent addenda.

Request for Early Opening shall mean a request by the DB Contractor to open up a portion or the entire Project to traffic prior to the Acceptance Deadline.

Request for Information (RFI) shall mean a written request for information prepared by the DB Contractor after Final Design to initiate the process for potential design changes or clarifications during the construction period.

Reserved Rights shall mean all of the following:

(a) The Mobility Authority's right, subject to TxDOT concurrence, to use, possess, develop and enjoy any real and personal property over, on, under or adjacent to the Final ROW

for other transportation or related facilities, including tunnels, flyovers, frontage roads, local roads, interchanges and fixed guide-ways; and

- (b) all right to use, and use of:
 - (i) all electrical, fiber optic and wireless conduit, cable, capacity, towers, antennas and associated equipment or other telecommunications equipment, hardware and capacity existing over, on, under or adjacent to any Final ROW installed by anyone, whether before or after the Effective Date, and all software which executes such equipment and hardware and related documentation, to the extent not necessary and required for traffic management for the Project or for other project purposes;
 - (ii) any area or space over, on, under or adjacent to the Final ROW for development and operation of any office, commercial, industrial, residential, retail or mixed use real estate project, including revenue-generating service or rest areas;
 - (iii) any equipment, facilities or capabilities for ITS studies or applications installed by or on behalf of the Mobility Authority and the right to install any such equipment, facilities or capabilities; and
 - (iv) any area or space over, on, under or adjacent to the Final ROW for any other commercial or non-commercial development or use.

Resident Engineer shall have the meaning provided in *Technical Provision 2*.

Responsible Party shall mean that party that is legally responsible for performing a Corrective Action or Preventive Action involving Hazardous Materials.

Retainage shall have the meaning set forth in *Section 13.3.10* of this DB Agreement.

Revised Project Baseline Schedule or Revised Project Schedule shall mean Mobility Authority approved modifications to the Project Baseline Schedule.

RFDP Documents shall mean all of the information and materials supplied to the DB Contractor in connection with the issuance of the RFQ, the RFDP, including Instructions to Proposers, and the Reference Documents and any addenda issued in connection therewith.

ROW Project Manager shall mean the DB Contractor's representative responsible for preparation and quality review of all documents required for the acquisition of all DB Contractor Designated ROW.

Rules shall have the meaning set forth in *Recital C* of this DB Agreement.

Safety Data Sheet (formerly **Material Safety Data Sheet**) shall mean a document that Federal law requires chemical manufacturers, distributors, and importers provide for each hazardous chemical to downstream users to communicate information on these hazards.

Safety and Health Plan or **Safety Plan** shall have the meaning set forth in *Technical Provision 25*.

Sampling and Analysis Plan shall mean a plan developed by the DB Contractor for the sampling and analysis of elements present at a Project site where Hazardous Materials may reasonably be expected to be encountered, as specified in *Technical Provision 9*.

Schedule Activity shall mean the smallest division of the Work at each WBS level to be tracked in the Project Schedule. Schedule Activities are elements of Work required for the timely completion of the Project. In addition to construction tasks, Schedule Activities include quality assurance tasks, environmental tasks, fabrication of structural steel and precast and prestressed concrete structures, material and equipment procurement, Utility Adjustment Work and delivery to the site or storage locations, and maintenance of traffic tasks.

Schedule of Values shall have the meaning set forth in *Technical Provision 5*.

Schematic Plan shall mean the roadway schematic plan for the design of the Project as set forth as *Exhibit D - Item 3* to this DB Agreement.

Schematic ROW shall mean any real property (which term is inclusive of all estates and interests in real property), improvements and fixtures within the lines established by the Mobility Authority in *Exhibit D - Item 3* to delineate the outside limits of the Schematic Plan, as such limits may be adjusted from time to time in accordance with the Contract Documents. The term specifically includes all air space, surface rights, and subsurface rights within the limits of the Schematic ROW.

Schematic ROW Maps and Documents shall mean the documents shown in *Exhibit D-Item 5*.

Scope of Work shall mean the document describing the scope of the Work, attached hereto as *Exhibit B*.

Section 7 Formal Consultation (see **Formal Consultation (Section 7)**).

Select Fill shall have the meaning provided in *Technical Provision 20*.

Service Line shall mean a Utility line, the function of which is to directly connect the improvements on an individual property to another Utility line located off such property, which other Utility line connects more than one such individual line to a larger system.

Site shall mean Schematic ROW, Additional Properties, New Utility Property Interests, and any temporary rights or interests that the DB Contractor may acquire at its own cost and expense in connection with the Project.

Site Investigation Report shall mean a report prepared by the DB Contractor on the investigative methods and techniques and analytical testing completed to adequately characterize the extent of impacts from Hazardous Materials at a site of concern as more particularly described in *Technical Provision 9*.

Site Recycling Plan shall mean the plan developed by the DB Contractor in accordance with *Technical Provision 26* that addresses recycling of materials on the Project.

State shall mean the State of Texas.

Subcontract shall mean any agreement by the DB Contractor with any other Person, Subcontractor or Supplier to perform any part of the Work or provide any materials, equipment or supplies for any part of the Work, or any such agreement at a lower tier, between a Subcontractor and its lower tier Subcontractor or a Supplier and its lower tier Supplier, at all tiers.

Subcontractor shall mean any Person with whom the DB Contractor has entered into any Subcontract to perform any part of the Work or provide any materials, equipment or supplies for the Project on behalf of the DB Contractor and any other Person with whom any Subcontractor has further subcontracted any part of the Work, at all tiers.

Substantial Completion shall mean the occurrence of all of the events and satisfaction of all of the conditions set forth in *Section 20.1.2* of this DB Agreement.

Supplemental Utility Assembly shall mean a compilation of utility documents in a format, and containing the documents, as described in *Technical Provision 8*.

Supplier shall mean any Person not performing work at or on the Site which supplies machinery, equipment, materials, hardware, software, systems or any other appurtenance to the Project to the DB Contractor or to any Subcontractor in connection with the performance of the Work. Persons who merely transport, pick up, deliver or carry materials, personnel, parts or equipment or any other items or persons to or from the Site shall not be deemed to be performing Work at the Site.

Surety shall mean each properly licensed surety company, insurance company or other Person approved by the Mobility Authority, which has issued any Payment Bond or Performance Bond.

Sustainability Level 2 Project shall have the meaning set forth in *Technical Provision 26*.

Sustainability Level 3 Project shall have the meaning set forth in *Technical Provision 26*.

Synthetic Absorbents and Absorbent Pads shall mean man-made products that are specialized to absorb high quantities of oil while repelling water.

System Integrator shall mean the Mobility Authority's contractor that shall design, supply, install, test and commission the toll collection system and ITS for the Project, including scanners, readers, loops, enforcement mechanisms, automated toll collection systems, and ITS Equipment.

Tangible Net Worth shall mean, for a corporation, the difference between (the sum of paid-in capital stock plus preferred stock plus retained earnings) less (the sum of treasury stock plus minority interest plus intangible assets e.g., goodwill, patents, licenses), all determined in accordance with Generally Accepted Accounting Principles ("GAAP") and as interpreted by the Securities and Exchange Commission in connection with financial statements filed pursuant to the Securities Exchange Act of 1934. With respect to a partnership or limited liability company, the term shall mean the sum of the partners' or members' capital accounts determined in accordance with GAAP.

Technical Provisions means the Technical Provisions attached to this DB Agreement as *Exhibit C*, as revised or amended pursuant to the DB Agreement.

Third Party Claims shall mean any and all claims, disputes, disagreements, causes of action, demands, suits, actions, judgments, investigations or proceedings brought by a Person that is not a Party with respect to damages, injuries, liabilities, obligations, losses, costs, penalties, fines or expenses (including attorneys' fees and expenses) sustained or incurred by such Person.

Threatened and Endangered Species shall mean any species listed by the USFWS as threatened or endangered pursuant to the Endangered Species Act, as amended, 16 U.S.C. §§ 1531, *et seq.* or any species listed as threatened or endangered pursuant to the State endangered species act.

Time and Materials Change Order shall mean a Change Order issued in accordance with *Section 14.7* of this DB Agreement.

Toll Gantry means the structures and equipment associated with collection of tolls at the locations described in *Exhibit D*.

Toll Gantry Completion Deadline(s) shall mean the deadlines by which the DB Contractor shall have completed construction of the infrastructure to support installation of toll equipment at the applicable gantry locations in accordance with *Section 18.1.2* of this DB Agreement and *Technical Provision 21*.

Total Suspended Solids shall mean total suspended matter in water, which is commonly expressed as a concentration in terms of milligrams per liter. The term is equivalent to nonfilterable residue, as used in 40 Code of Federal Regulations Part 136 and in previous editions of the publication entitled, *Standard Methods for the Examination of Water and Wastewater*.

Traffic Control Device Installation Records shall have the meaning set forth in *Technical Provision 22.4.3.2*.

Turnpike Intelligent Management/Operation Systems shall have the meaning set forth in *Technical Provision 18*.

TxDOT Austin District Standards shall mean those standards for design and construction contained in *Exhibit D - Item 3*.

TxDOT Prices shall mean the average low bid prices for the Austin District of TxDOT, as published by TxDOT with respect to certain specified materials and products, provided that TxDOT statewide published prices shall be applied if no Austin District prices are available for a specified material or product.

TxDOT Specifications shall mean the Texas Department of Transportation Standard Specifications for Construction and Maintenance of Highways, Streets and Bridges, adopted by the Texas Department of Transportation.

TxDOT Standard Plans shall mean the Statewide Standard plans/files maintained by TxDOT Divisions, the TxDOT Austin District Standard plans/files, and Modified Standard plans/files particular to the Project developed by the DB Contractor. The TxDOT Austin District Standard plans/files shall take precedence over the Statewide Standard plans/files maintained by TxDOT Divisions.

TxDOT Standards shall mean the Texas Department of Transportation Policies, Procedures, Guidelines, Manuals, Standard Drawings, General Notes and other related documents published on TxDOT's internet system, provided that any reference to TxDOT Standards and Specifications shall include TxDOT Austin District Standards, which shall take precedence over statewide TxDOT Standards and Specifications or any other local district standards.

TxDOT Utility Manual shall mean the Utility Manual issued by the Right of Way Division of TxDOT, as the same may be amended, supplemented or replaced from time to time.

Ultimate Design or **Ultimate Project Design** shall mean the design included in the roadway Schematic Plan set forth in *Exhibit D - Item 3*.

Unidentified Utility shall mean any Utility impacted by the Project (other than a Service Line) which is not an Identified Utility.

Uniform Act shall mean the Federal Uniform Relocation Assistance and Real Property Acquisition Policies Act, P.L. 91-646, as amended.

Unknown Hazardous Materials shall mean Hazardous Materials that meet all of the following criteria:

- (a) The Hazardous Materials are in, on or under the Schematic ROW, or parcels added to the Site by a Mobility Authority-Directed Change or required due to a Force Majeure Event as of the date the Mobility Authority makes available to the DB Contractor the affected parcel;
- (b) The existence of such Hazardous Materials was not disclosed in, or ascertainable from, the RFDP Documents, and was not otherwise known to the DB Contractor prior to the Proposal Due Date; and
- (c) The Hazardous Materials are not required to be removed and disposed of due to a Release of Hazardous Materials by the DB Contractor.

For purposes of this definition, "makes available" means (i) the Effective Date for parcels acquired as of the Effective Date or (ii) as to parcels not yet acquired as of the Effective Date, the date the DB Contractor first receives access to the parcel in accordance with the Contract Documents. The term Unknown Hazardous Materials does not include (1) Hazardous Materials falling within paragraph (f) of the definition for Force Majeure; or (2) Hazardous Materials with respect to the sand filters located within the water quality ponds described in *Exhibit C, Attachment 15-1* to this DB Agreement.

Utility(ies) or **utility(ies)** shall mean (1) a public, private, cooperative, municipal and/or government line, facility or system used for the carriage, transmission and/or distribution of cable television, electric power, telephone, telegraph, water, gas, oil, petroleum products, steam, chemicals, hydrocarbons, telecommunications, sewage, storm water not connected with the drainage of the Project, and similar substances that directly or indirectly serve the public, and/or (2) a Private Pipeline. The term "Utility" or "utility" specifically excludes (a) storm water facilities providing drainage for the Final ROW, and (b) Intelligent Transportation Systems, street lights and traffic signals. The necessary appurtenances to each utility facility shall be considered part of such utility. Without limitation, any Service Line connecting directly to a utility shall be considered an appurtenance to that utility, regardless of the ownership of such Service Line.

Utility Accommodation Rules (UAR) shall mean the provisions contained in 43 TAC 21.31 through 21.56, as the same may be amended, supplemented or replaced from time to time.

Utility Adjustment Agreement shall mean an agreement between the DB Contractor, TxDOT or the Mobility Authority and a Utility Owner which sets forth terms and conditions for one or more Utility Adjustments, as the same may be amended or supplemented from time to time and as more particularly described in *Technical Provision 8*. A document is a "**Utility Adjustment Agreement**" if it meets the foregoing definition, without regard to the title of the document. A reference in the Contract Documents to any Utility Adjustment Agreement shall include, in addition to the Utility Adjustment Agreement, any Utility Adjustment Agreement Amendment executed by the DB Contractor, TxDOT or the Mobility Authority and the Utility Owner with respect thereto, as well as any informal supplement or modification entered into between the DB Contractor, TxDOT or the Mobility Authority and the Utility Owner as permitted by *Technical Provision 8*. The term "**Master Utility Adjustment Agreement**" shall have the same meaning.

Utility Adjustment Agreement Amendment shall mean an agreement between the DB Contractor or the Mobility Authority and the Utility Owner which amends a Utility Adjustment Agreement, as more particularly described in *Technical Provision 8*.

Utility Adjustment Concept Plan shall mean a design document which shows the existing location and the DB Contractor's Adjustment recommendation for each Utility impacted by the Project, as more particularly described in *Technical Provision 8*.

Utility Adjustment Field Modification shall mean a modification to an Adjustment or group of Adjustments as described in *Technical Provision 8*.

Utility Adjustment Plan(s) shall mean the construction plans for a particular Adjustment or group of Adjustments as described in *Technical Provision 8*.

Utility Adjustment Work shall mean (a) the work associated with Adjustment of Utilities as necessary to accommodate the Project Design or permit construction of the improvements of the Project (except for Early Adjustments), and (b) any Betterments added to the Work pursuant to *Section 14.12.2* of this DB Agreement. The term includes all coordination, design, design review, permitting, construction, inspection, maintenance of records, relinquishment of Existing Utility Property Interests, preparation of Joint Use Agreements, and acquisition of New Utility Property Interests as necessary for the work described in the preceding sentence, whether provided by the DB Contractor or by the Utility Owners, and all other work described as "**Utility Adjustment Work**" or "**Incidental Utility Adjustment Work**" in *Technical Provision 8*.

Utility Appurtenance Adjustment shall mean the adjustment of Utility appurtenances (e.g. manholes, valve boxes, and vaults) for line and grade upon completion of roadway work.

Utility Assembly shall mean a compilation of utility documents that fully describes the applicable Utility Adjustment(s) in a format, and containing the documents, as described in *Technical Provision 8*.

Utility Clearance Letter shall have the meaning set forth in *Technical Provision 8*.

Utility Enhancement shall mean a Betterment or a Utility Owner Project.

Utility Joint Use Acknowledgement shall mean an agreement between (i) the Mobility Authority and/or TxDOT and (ii) a Utility Owner which establishes the rights and obligations of the Mobility Authority and/or TxDOT and the Utility Owner with respect to occupancy of the Final ROW by a Utility owned by such Utility Owner.

Utility MOU shall mean any non-binding agreement or memorandum of understanding between (i) the Mobility Authority or TxDOT and (ii) a Utility Owner establishing a general framework for the Adjustment of such Utility Owner's Utilities as necessary for the Project.

Utility Owner shall mean the owner or operator of any Utility (including both privately held and publicly held entities, cooperative utilities, and municipalities and other governmental agencies).

Utility Owner Delay shall mean a delay to the Critical Path which is directly attributable to the Utility Owner's failure to cooperate with the DB Contractor with respect to the Adjustment of its Utility, within the time period reasonably scheduled for performance of such work by the DB Contractor, where the DB Contractor and such Utility Owner have not yet executed a Utility Adjustment Agreement addressing such Adjustment.

Utility Owner Project shall mean the design and construction by or at the direction of a Utility Owner (or by the DB Contractor pursuant to *Section 14.12.2.3* of this DB Agreement) of a new Utility other than as part of a Utility Adjustment. Betterments are not Utility Owner Projects. Utility Owner Projects shall be entirely the financial obligation of the Utility Owner.

Utility Strip Map shall mean the plan showing all of the Utilities within the Final ROW as more fully described in *Technical Provision 8*.

Utility Tracking Report shall mean a report regarding Utilities likely to be impacted by the Project which the DB Contractor shall maintain on a current basis, and which the DB Contractor shall periodically submit to the Mobility Authority, as more particularly described in *Technical Provision 8*.

Warranty shall have the meaning set forth in *Section 12.1.1* of this DB Agreement.

Warranty Bond shall have the meaning set forth in *Section 9.4* of this DB Agreement, the form of which is attached to this DB Agreement as *Exhibit K*.

Water Pollution Abatement Plan shall mean a detailed plan required by the Edwards Aquifer Rules for projects in the Edwards Aquifer Recharge Zone, which outlines best management practices that will be implemented to protect water quality from project activity. Requirements for Water Pollution Abatement Plans are outlined in 30 TAC 213.5(b).

Water Quality Specialist shall mean the person designated by the Environmental Compliance Manager to provide expertise in conducting development activities in accordance with the storm water management and water quality provisions of the TPDES (see *Technical Provision 9*).

Work shall mean all of the work required to be furnished and provided by the DB Contractor under the Contract Documents, including all administrative, design, engineering, real property acquisition and occupant relocation, support services, Utility Adjustment Work to be furnished or provided by the DB Contractor, reimbursement of Utility Owners for Utility Adjustment Work furnished or provided by such Utility Owners or their contractors and consultants, procurement, professional, manufacturing, supply, installation, construction, supervision, management, testing, verification, labor, materials, equipment, maintenance, documentation and other duties and services to be furnished and provided by the DB Contractor

as required by the Contract Documents, including all efforts necessary or appropriate to achieve Final Acceptance of the Project except for those efforts which such Contract Documents expressly specify will be performed by Persons other than members of the DB Contractor Group.

Work Breakdown Structure (WBS) shall mean the organization of Project activities and elements as more particularly described in *Technical Provision 5*.

[END OF DEFINITIONS]

EXHIBIT B

SCOPE OF WORK

FOR

DEVELOPMENT OF THE

183 NORTH MOBILITY PROJECT

THROUGH A DESIGN-BUILD AGREEMENT

PROJECT NUMBER: 20183N22701C



BY THE

CENTRAL TEXAS REGIONAL MOBILITY AUTHORITY

EXECUTION COPY

1.0 SCOPE OF WORK

1.1 GENERAL STATEMENT OF SCOPE AND USE OF THIS DOCUMENT

This document provides information relating to, and requirements applicable to, the Work to be performed under the Design-Build Agreement (the “DBA”) for the 183 North Mobility Project. This document shall be interpreted as provided in the DBA. Initially capitalized terms not otherwise defined in the body of this Exhibit B – Scope of Work have the definitions set forth in Exhibit A – Abbreviations and Definitions of the DBA. References to Exhibits shall mean Exhibits to the DBA, unless otherwise specified. References to sections contained herein shall mean sections of this Exhibit B – Scope of Work, unless otherwise specified. References to Attachments shall mean documents included in Exhibit C – Technical Provisions, unless otherwise specified. The Reference Documents are listed in Exhibit D – Reference Documents.

The DB Contractor is responsible for the completion of all Work in accordance with the requirements of the DBA. The Mobility Authority’s criteria for design and construction of the Project are specified in Exhibit C. All Work shall be done in accordance with Exhibit C even if not referenced under specific section herein. The Basic Configuration is provided as Exhibit D – Item 3. The DB Contractor shall develop the Project Design based on this Exhibit B and Exhibit C.

Tolling guidelines and associated documents have been developed for the Project and are included as Exhibit D – Item 3. These plans have been provided for informational purposes. Conflicts between Exhibit B, the Schematic Plan, and Exhibit C identified by the DB Contractor shall be brought to the Mobility Authority’s attention.

1.2 GENERAL PROJECT DESCRIPTION

The Project extends generally from State Highway (SH) 45 North/Ranch-to-Market (RM) 620 to State Loop 1 (MoPac), a distance of approximately nine miles as shown in Figure 1.

183 North Mobility Project

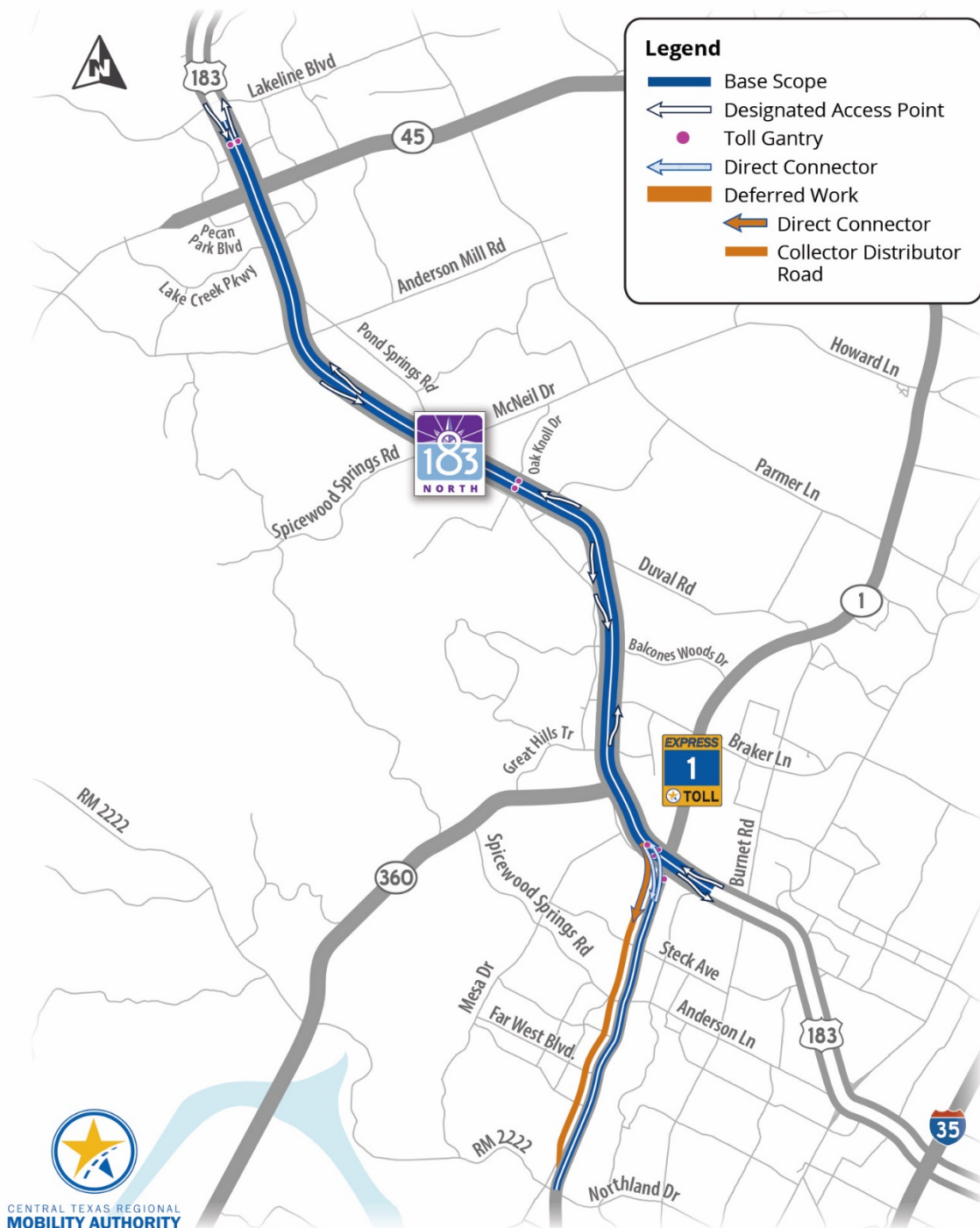

Figure 1: 183 North Mobility Project Map

The Project will consist of a Base Scope and Deferred Work as described in this *Exhibit B* and depicted on the schematic plan contained in *Exhibit D – Item 3*. The Work shall be in accordance with the Schematic Plan and include but is not limited to the following elements as depicted on the Schematic Plan:

1.2.1 Base Scope

The Base Scope will generally consist of the construction of four express lanes (two in each direction) and widening of the existing United States Highway (US) 183 as required to bring the total number of general purpose lanes to four in each direction. Other improvements include the addition of direct connector ramps providing access between the new express lanes on US 183 and the existing express lanes on MoPac, ITS infrastructure to support tolling of the express lanes in addition to traffic management/incident management, a new shared-use path, new sidewalks, cross-street connections for bicycles/pedestrians along US 183, and other improvements and widening necessary for the aforementioned improvements.

1.2.1.1 US 183

- Construct one to two variable-priced (tolled) express lanes in each direction, northbound and southbound, along US 183 from just north of SH 45N/RM 620 on the north end to Loop 1 on the south end (approximately 7.9 miles). The limits of the US 183 two-lane express lanes are generally from Anderson Mill Road to the Loop 1 direct connectors near Loop 360 (approximately 5.3 miles).
- Construct US 183 express-lane transitions to existing 183A Toll north of SH 45N and to existing US 183 south of Loop 1.
- Construct entrance and exit ramps between the express lanes and general purpose, also referred to as express lane ingress and egress ramps, generally at the following locations:
 - Southbound ingress near Balcones Club Drive
 - Southbound egress near Duval Road
 - Southbound ingress Balcones Woods Drive
 - Northbound egress near Roxie Drive
 - Northbound ingress near Tweet Court
 - Northbound egress near Celeta Lane
- Construct one-lane per direction express-lane direct connector providing access between US 183 express lanes and Loop 1 express lanes.
- Construct a fourth US 183 (non-tolled) general purpose lane, northbound and southbound, generally in those areas where only three general purpose lanes currently exist: northbound between Braker Lane and McNeil Drive/Spicewood Springs Road; southbound from approximately Lake Creek Parkway to the entrance ramp from SH 45N; and southbound between approximately one mile north of McNeil Drive/Spicewood Springs Road and Loop 1.

- Widen US 183 general purpose lanes and reconstruct US 183 entrance/exit ramps and, if necessary, auxiliary lanes and speed change lanes to accommodate the above US 183 improvements within the Project limits.
- Reconstruct US 183 southbound frontage roads generally from Thunder Creek Drive to Angus Road nominally from US 183 centerline Station 101+25 to Station 112+00 and from Loop 360 to Stonelake Boulevard (approximately 0.4 miles) nominally from US 183 centerline Station 200+00 to Station 212+00.
- Construct new toll gantries for northbound and southbound express lanes between Anderson Mill Road and McNeil Drive/Spicewood Springs Road, and for northbound and southbound express lanes south of Capital of Texas Highway, including any direct connections with the MoPac express lanes
- Reconstruct northbound gantry south of Lakeline Mall Drive and accommodate proposed northbound express lane gantry. Construct southbound express lane gantry north of SH 45.
- Conduct all Work necessary to construct and install the Express Lanes and toll infrastructure. All civil, electrical and communication infrastructure required to support the toll system and ITS devices shall be provided by the DB Contractor as specified in Exhibit C – Technical Provisions 18 and 21, and Exhibit C – Attachment 21-1 – Toll Facility and ITS Responsibility Matrix. The System Integrator will be responsible for mounting, installing, terminating and testing the toll system and ITS equipment owned by the Mobility Authority. The DB Contractor shall be responsible for procuring mounting, installing, terminating and testing ITS equipment owned by TxDOT.
- The DB Contractor shall be responsible for relocating, as necessary, and reconnecting TxDOT-owned Project ITS to the existing network, including communications links Combined Transportation and Emergency Communications Center (CTECC), the TxDOT Austin District, and the TxDOT Traffic Safety Division Office in Cedar Park.
- Construct shared use (bicycle/pedestrian) path and associated improvements to connect the existing paths located along Lake Creek Parkway, Pond Springs Road, and Jollyville Road.
- Edge mill and overlay the US 183 frontage road pavement within the project limits.
- Restripe all cross streets except for Lake Creek Parkway, Braker Lane, and Loop 360 to include bike lanes under US 183 as described in the NEPA Documents. Provide bike lane striping within the schematic ROW limits and transition beyond, as necessary, to match existing lane striping. Mill and overlay full width of roadway pavement a minimum of 1-inch deep matching the extent of intersection restriping. Reconstruct all traffic signals and associated improvements impacted by widening required to provide bike lanes. If the DB Contractor can demonstrate that the existing bike lanes at Spicewood Springs Rd / McNeil Dr meet requirements, then Spicewood Springs Rd / McNeil Dr can be added to the exclusion list above.
- Construct shared use paths, sidewalks and ADA improvements along one or both sides of US 183 frontage roads from SH 45N/RM 620 to Business Park Drive near Loop 1.

- Reconstruct select non-compliant existing sidewalks, curb ramps, and other ADA elements within the Schematic Right of Way as further defined below. Reconstructed elements shall comply with the current *TxDOT Roadway Design Manual* requirements. The DB Contractor shall correct the following deficiencies as identified in the Sidewalk Assessment Report and any that would be encountered during the design development:
 - Change in Level and Ground Space: Correct all general items;
 - Curb Ramps: Construct curb ramps where they are no curb ramp connections to the existing sidewalks. Retrofit existing curb ramps with Detectable Warning Surfaces at pedestrian street crossings/refuge. Correct all non-compliant curb ramps;
 - Openings: Correct all nonstandard openings;
 - Cross slopes: Correct sections of sidewalks with cross slopes greater than 2.5% to meet the current requirements;
 - Clear Width: Correct all existing sidewalk clear width deficiency per TxDOT Roadway Design Manual of providing at least 48 inches; and
 - Wet Conditions: Correct locations with wet conditions.

1.2.1.2 Loop 1

- Construct Loop 1 additional one-lane variable-priced (tolled) express lanes in each direction, northbound and southbound, generally from the US 183 express-lane direct connectors to Anderson Lane (approximately 0.7 miles).
- Construct Loop 1 express-lane transitions between the express-lane direct connectors and existing Loop 1 express lanes including modifications to the existing northbound and southbound express-lane ingress and egress ramps located between Far West Boulevard and RM 2222.
- Widen Loop 1 and reconstruct Loop 1 entrance/exit ramps and, if necessary, auxiliary lanes and speed change lanes to accommodate the above Loop 1 improvements within the Project limits (approximately 3.2 miles).
- Modify existing noise walls to accommodate Project improvements.
- Mill and overlay with PFC the entire roadway within limits of restriping.

1.2.1.3 US 183 and Loop 1

- Construct, widen, or modify roadway elements to accommodate Project improvements.
- Construct, widen, or modify bridges and retaining walls to accommodate Project improvements.
- Repair and restore each existing bridge structure and bridge class culvert with a condition rating of less than 7. This work is limited to those structures identified in *Exhibit C Attachment 12-1*.

- Construct and/or modify drainage systems to accommodate Project improvements.
- Construct and/or modify water detention/quality systems to accommodate Project improvements.
- Construct aesthetic treatment/application to new and existing structures.
- Construct and/or modify Toll and ITS facilities to accommodate Project improvements.
- Construct and/or modify lighting, signing, pavement markings, and traffic signal elements to accommodate Project improvements.
- Perform utility adjustments to accommodate Project improvements.

1.2.1.4 City of Austin Utility Work

- Replace the existing 8-inch wastewater line crossing US 183 at approximate station 955+70. Design replacement wastewater line per the requirements of the Austin Utility Criteria Manual and specifications. Replacement wastewater line shall be encased.
- Extend 36-inch casing on the existing 24-inch waterline crossing US 183 at approximate station 997+75. Casing shall be extended beyond the proposed retaining walls per the requirements of the Austin Utility Criteria Manual and specifications.
- Extend 20-inch casing on the existing 8-inch wastewater line crossing US 183 at approximate station 70+20. Casing shall be extended beyond the proposed retaining walls per the requirements of the Austin Utility Criteria Manual and specifications.
- Extend the 36-inch casing on the existing 24-inch water line crossing US 183 at approximate station 156+00. Casing shall be extended beyond the proposed retaining walls per the requirements of the Austin Utility Criteria Manual and specifications.

1.2.2 Deferred Work

The Deferred Work will generally consist of the design and construction of an additional direct connector ramp from the new southbound US 183 express lanes to the Loop 1 general purpose lanes providing local access from southbound US 183 to Anderson Lane and Far West Blvd., thereby reducing local access weaving movements on the southbound Loop 1 general purpose lanes from the southbound express lanes between the US 183/Loop 1 interchange and Far West Blvd.

The proposed direct connector from the southbound US 183 express lanes provides direct access to the existing Loop 1 southbound frontage road just south of Steck Avenue. The direct connector transitions into a collector distributor road between Steck Avenue and Spicewood Springs Road. The direct connector then converts into a southbound Loop 1 frontage road auxiliary lane between just south of Spicewood Spring Road and just north of Far West Boulevard. This hybrid facility includes exit ramps to the southbound Loop 1 frontage road just south of Steck Avenue, just south of Spicewood Spring Road, an entrance ramp to the collector distributor road just north of Spicewood Springs Road and an entrance ramp to the southbound Loop 1 general purpose lanes just north of Far West Boulevard.

The hybrid direct connector/collector distributor roadway generally consists of one 14-foot wide lane with 6-foot and 4-foot shoulders as shown on the Schematic Plan in Exhibit D – Item 3.

1.2.2.1 US 183

- Construct a one-lane direct connector ramp providing access between US 183 southbound express-lane direct connector and Loop 1 southbound non-tolled collector-distributor stated in the Loop 1 section below (approximately 0.3 miles).

1.2.2.2 Loop 1

- Construct Loop 1 a one-lane collector-distributor road with auxiliary lanes and ramps from the US 183 southbound express-lane direct connector to Anderson Lane (approximately 1.0 mile). Ramps include exit ramps to Steck Avenue and Anderson Lane and an entrance ramp from Steck Avenue.
- Design and reconstruct the existing noise wall between Loop 1 and the N MoPac Service Rd as necessary and as reflected in the Environmental Documents to accommodate the Collector Distributor. The DB Contractor shall not use materials from the existing noise wall in the construction of the replacement noise wall.

1.2.3 Ultimate Design

The Ultimate Design is defined in Exhibit A. The Ultimate Design elements are depicted in Exhibit D – Item 3. The DB Contractor shall accommodate the Ultimate Design by designing and constructing the Project elements such that no Project elements shall be in conflict with the Ultimate Design elements. The DB Contractor shall be responsible for demonstrating how the Project is accommodating the Ultimate Design.

The Ultimate Design elements generally consists of:

- **Ultimate US 183 Direct Connectors at RM 620:** US 183 NB to RM 620 WB and the RM 620 EB to US 183 SB direct connectors. No elements, including substructure or foundations, are required to be constructed.
- **Ultimate Ramps between 183N Express Lanes and US 183/ RM 620 Direct Connectors.** Elevated ramps and approaches between Lake Creek Parkway and Anderson Mill Road. No bridge elements are required to be constructed. All elements of the roadway approaches as shown on the Schematic Plan shall be designed and constructed to accommodate the Ultimate Design.

1.3 DB CONTRACTOR SCOPE OF WORK OBLIGATIONS

The DB Contractor shall not rely on the physical description contained in this Exhibit B to identify all Project components. The DB Contractor shall determine the full scope of the Project through examination of the Contract Documents and the Project Site, or as may be reasonably inferred from such examination. Any revisions to this Exhibit B included in the DB Contractor's Proposal may be implemented only if

approved in writing by the Mobility Authority and incorporated into the DBA. Acceptance of the DB Contractor's Proposal, and/or award of the DBA, shall not serve as written approval for deviations from the scope. Unless expressly stated otherwise, no provision contained herein which states that the DB Contractor may propose revisions shall be construed to allow the DB Contractor to implement any revisions without the Mobility Authority's prior written approval. The Mobility Authority, at its sole discretion, shall have the right to accept or reject any DB Contractor-proposed revisions to this Exhibit B.

The DB Contractor shall provide the personnel, equipment, materials, and tools necessary to plan, design, construct, and perform all Work, including final Utility Adjustments.

If DB Contractor-Designated ROW is required by the DB Contractor's design and approved by the Mobility Authority, the DB Contractor will be responsible for these acquisition costs and services.

The DB Contractor's organization must be structured and staffed with experienced, qualified personnel to manage the Work in a manner that ensures safety, quality, and environmental sensitivity. The DB Contractor shall provide for Key Personnel and shall abide by the procedures set forth in the Contract Documents with respect to Key Personnel, including removal and replacement requirements.

The DB Contractor shall coordinate and report to the Mobility Authority all activities with Governmental Entities and other Persons that are directly or indirectly impacted by the Work.

The DB Contractor shall be responsible for the documentation of all Work and Project-related actions.

The DB Contractor shall be responsible for assuring quality performance.

The DB Contractor shall be responsible for performing the environmental commitments reflected in the Environmental Documents.

The DB Contractor shall be responsible for the adequacy of its plan and schedule to manage its personnel, equipment, materials, Subcontractors, and other resources to meet the requirements of the Contract Documents.

The DB Contractor shall cooperate with the System Integrator (SI) to be separately appointed by the Mobility Authority and which will be responsible for delivery of the toll system and toll-related ITS owned by the Mobility Authority.

The DB Contractor shall be responsible for assisting the Mobility Authority with the implementation of a comprehensive Community Relations Program (CRP) to inform the public throughout the design and construction of the Project.

The DB Contractor shall be responsible for all actions and associated costs for obtaining all Governmental Approvals for the Project or otherwise necessary to undertake and complete the Work regardless of whether the Mobility Authority had initiated the approval process (except those expressly identified and specified as the responsibility of others). The DB Contractor is responsible for satisfying and complying with all requirements (including, but not limited to, testing, monitoring, and documentation) of the individual Governmental Approvals (including those obtained by others). Unless

otherwise approved in writing by the Mobility Authority, all permits must be closed prior to Final Acceptance.

The DB Contractor shall provide documentation of the existing conditions along the entire Project corridor, including all adjacent facilities and Utilities that could be impacted by Work operations by video and/or photos, prior to starting construction operations.

The DB Contractor unless otherwise specified herein, shall provide design be governed by the standards, policies, and specifications in the DBA, this Exhibit B, and Exhibit C with all addenda, supplements, and revisions thereto. This requirement shall include all Reference Documents to the extent such Reference Documents are specifically incorporated into the Contract Documents.

The DB Contractor shall use sound engineering judgment in applying design criteria in situations where a strict adherence to these criteria is not possible. If Project conditions warrant that an exception to the design criteria be considered, the DB Contractor shall submit the Design Exception with justification in writing to the Mobility Authority for the Mobility Authority's review and comment. Use of Design Exceptions is discouraged and the DB Contractor shall investigate and present alternatives prior to submitting a Design Exception to the Mobility Authority. The DB Contractor shall resolve Mobility Authority review comments prior to formal submission of a Design Exception to TxDOT and FHWA. The Mobility Authority reserves the right to reject Design Exceptions.

Design Exceptions shall be submitted in accordance with the procedures outlined in the TxDOT *Roadway Design Manual* and other relevant design references. The DB Contractor shall be responsible for obtaining all approvals for Design Exceptions.

1.4 PERFORMANCE AND COMMENCEMENT OF THE WORK

This Exhibit B shall be used to clarify specific requirements applicable to this Project. All Work shall be performed in accordance with the applicable requirements of Exhibit C, even if not referenced under specific section herein. The DB Contractor shall manage, plan, execute, and control all aspects of the Work except for those retained by the Mobility Authority.

The Mobility Authority intends to issue NTP1 on or about the date of execution of the DBA. This will allow the DB Contractor to perform NTP1 Work. Issuance of NTP1 authorizes the DB Contractor to enter the Project ROW in order to conduct surveys and site investigations, including geotechnical, Hazardous Materials and Utility Work. Upon acceptance of the design quality management plan, NTP 1 also authorizes DB Contractor to commence Design Work in accordance with Exhibit C.

Following issuance of NTP1, but prior to issuance of NTP2, the DB Contractor may perform Utility Work in accordance with Technical Provisions 8 to include coordination, design, design review, permitting, and Utility Adjustment construction. Following issuance of NTP1, but prior to issuance of NTP2, the DB Contractor may perform work effort related to DB Contractor-Designated ROW acquisition to include mapping, surveying, appraisal, and appraisal review services.

The Mobility Authority intends to issue both NTP2 and NTP3 as soon as possible after the date of the finance closing. Issuance of NTP2 authorizes the DB Contractor to perform all the Base Scope Work that

is not included in NTP1 Work. Issuance of NTP3 authorizes the DB Contractor to commence the Deferred Work.

EXHIBIT C

TECHNICAL PROVISIONS

FOR

DEVELOPMENT OF THE

183 NORTH MOBILITY PROJECT

THROUGH A DESIGN-BUILD AGREEMENT

PROJECT NUMBER: 20183N22701C



BY THE

CENTRAL TEXAS REGIONAL MOBILITY AUTHORITY

EXECUTION COPY

Table of Contents

1.0	PROJECT ADMINISTRATION AND MANAGEMENT	1-1
1.1	Introduction.....	1-1
1.1.1	General Requirements.....	1-1
1.1.2	Project Management Plan	1-2
1.1.3	Key Personnel.....	1-3
1.1.4	Communication and Partnering	1-5
1.1.5	DB Contractor Subcontracts	1-7
1.2	Facilities, Office Space, and Equipment.....	1-8
1.2.1	General Requirements.....	1-8
1.2.2	Mobility Authority Project Office Space	1-8
1.2.3	Mobility Authority Project and Field Office Services and Systems.....	1-10
1.2.4	Mobility Authority Office Space Requirements.....	1-10
1.2.5	Mobility Authority Office Equipment.....	1-11
1.3	Project Records	1-12
1.3.1	Documentation Media.....	1-12
1.3.2	Distribution of Communications.....	1-12
1.3.3	Electronic File Backups	1-13
1.3.4	Project Office Documentation.....	1-13
1.3.5	Document Control	1-15
1.4	Computer Software Requirements	1-15
1.4.1	General Guidelines.....	1-15
1.4.2	Required Project Software	1-15
1.4.3	Drawing Production – Computer Aided Drafting and Design (CADD)	1-16
1.4.4	Roadway Geometric Design	1-16
1.4.5	Three-Dimensional (3-D) Design	1-16
1.4.6	3-D Design Requirements.....	1-16
1.4.7	Immersive 3-D Review Meetings	1-17
1.4.8	3-D Design Deliverables.....	1-18
1.4.9	Drainage Design	1-19
1.4.10	Geotechnical Design.....	1-19
1.4.11	Pavement Design	1-20
1.4.12	Structural Design	1-20
1.4.13	Sign Design.....	1-21
1.4.14	Traffic Modeling and Signal Design.....	1-21
1.4.15	Advanced Traffic Management System (ATMS) Design.....	1-21
1.4.16	Architectural Plans.....	1-21
1.4.17	Project Scheduling	1-22
1.4.18	PC Operating System, Word Processing, and Spreadsheets.....	1-22
1.4.19	Construction Quality Control Inspection and Material Testing.....	1-22
1.5	Electronic Communications Requirements.....	1-22
1.5.1	Communications Management	1-22
1.5.2	Electronic Files	1-22

1.5.3	Mobility Authority Audit.....	1-23
1.5.4	Network Communications.....	1-23
1.5.5	File Transfer Protocol.....	1-23
1.5.6	E-mail Guidelines.....	1-23
1.6	Submittals.....	1-24
2.0	QUALITY MANAGEMENT.....	2-1
2.1	Quality Management Program.....	2-1
2.1.1	Responsibilities.....	2-1
2.1.2	Program Goals.....	2-1
2.1.3	Quality Management Plans.....	2-1
2.2	Definitions.....	2-3
2.3	Design Quality Management.....	2-4
2.3.1	Design Quality Management Plan (DQMP).....	2-4
2.3.2	Design Quality Control/Assurance Personnel.....	2-7
2.3.3	Design Quality Control.....	2-7
2.3.4	Design Quality Assurance.....	2-8
2.3.5	Design Acceptance.....	2-8
2.3.6	Submittal and Review Process.....	2-10
2.3.7	Design Submittals.....	2-12
2.3.8	Plan Submittal Requirements.....	2-15
2.3.9	Resubmittal Process.....	2-17
2.3.10	Released-for-Construction Submittals.....	2-18
2.3.11	Design Changes.....	2-19
2.3.12	Early Release for Construction (ERFC).....	2-20
2.4	Construction Quality Management.....	2-21
2.4.1	Construction Quality Management Plan (CQMP).....	2-22
2.4.2	Construction Quality Control and Material Acceptance.....	2-25
2.4.3	Construction Quality Control.....	2-27
2.4.4	Mobility Authority Material Acceptance.....	2-28
2.4.5	Independent Assurance and Testing Dispute Resolution.....	2-29
2.4.6	Material Inspection and Testing.....	2-29
2.4.7	Reporting, Record-Keeping, and Documentation.....	2-29
2.4.8	Requirements of Laboratories.....	2-31
2.4.9	Source and Quality of Materials.....	2-31
2.4.10	Access to Testing Facilities.....	2-32
2.4.11	Nonconformance Report.....	2-33
2.4.12	Construction Documentation.....	2-33
2.5	Submittals.....	2-38
3.0	WARRANTIES.....	3-1
3.1	Referenced Standards and Guidelines.....	3-1
3.2	Summary of Project Warranties.....	3-1
3.3	Warranty Requirements.....	3-2

3.3.1	Final Warranty Acceptance (FWA).....	3-2
3.3.2	Warranty Bond.....	3-3
3.3.3	Rights and Responsibilities of the Mobility Authority.....	3-3
3.3.4	Responsibilities of the DB Contractor.....	3-4
3.3.5	Evaluation Method.....	3-5
3.3.6	Corrective Action Requirements.....	3-5
3.3.7	Emergency Repairs.....	3-6
3.4	Warranty Specifications.....	3-6
3.4.1	Flexible Pavement: New Constructed Hot-Mix Asphalt.....	3-6
3.4.2	Rigid Pavement: New Concrete.....	3-8
3.4.3	Structural Concrete.....	3-10
3.4.4	Steel Paint Systems.....	3-12
3.4.5	Concrete Sealer Systems.....	3-12
3.4.6	Differential Settlement of New Roadway Grade (Including Bridge Fills).....	3-13
3.4.7	Settlement and Deflection: Sound, Retaining, and Neighborhood Walls and Barriers.....	3-14
3.4.8	Signing (Permanent).....	3-15
3.4.9	Traffic Signals.....	3-15
3.4.10	Turf and Landscape/Tree Establishment.....	3-15
3.4.11	Lighting.....	3-16
3.4.12	Utilities.....	3-17
3.4.13	Buildings, Toll Facilities, and Related Facilities.....	3-17
3.4.14	Pavement Markings and Flexible Delineators.....	3-17
3.5	Failure Adjustments Terms.....	3-17
3.6	Submittals.....	3-18
4.0	COMMUNITY RELATIONS PROGRAM.....	4-1
4.1	Introduction.....	4-1
4.2	Community Relations Program (CRP).....	4-1
4.3	Staffing Requirements.....	4-2
4.4	Project Website/Social Media.....	4-3
4.5	Special Events and Activities.....	4-4
4.6	Community/Business Outreach.....	4-5
4.7	Briefings, Meetings, and Coordination.....	4-7
4.8	Emergency Response Activities.....	4-8
4.9	Submittals.....	4-9
5.0	PROJECT SCHEDULE.....	5-1
5.1	General Requirements.....	5-1
5.2	Project Baseline Schedule.....	5-3
5.2.1	General.....	5-3
5.2.2	Work Breakdown Structure.....	5-4
5.2.3	Project Baseline Schedule Requirements.....	5-5
5.2.4	Schedule of Values.....	5-6

5.2.5	Project Baseline Schedule Coding	5-7
5.2.6	Calendars	5-8
5.2.7	Milestones/Constraints.....	5-8
5.2.8	Activities.....	5-9
5.2.9	Changes	5-9
5.2.10	Float.....	5-10
5.2.11	Narrative	5-10
5.2.12	Project Baseline Schedule Submission.....	5-11
5.2.13	Utility, Railroad, and Other Third Party Submittals	5-12
5.2.14	System Integrator Coordination.....	5-12
5.3	Project Status Schedule Updates	5-12
5.3.1	General Requirements.....	5-12
5.3.2	Narrative	5-13
5.3.3	Submittal Requirements.....	5-15
5.4	As-Built Schedule	5-16
5.5	Time Impact Analysis.....	5-16
5.6	Recovery Schedule.....	5-18
5.7	Submittals	5-19
6.0	RAILROAD COORDINATION	6-1
6.1	General Requirements	6-1
6.2	Submittals	6-2
7.0	RIGHT-OF-WAY.....	7-1
7.1	General	7-1
7.1.1	Standards.....	7-1
7.1.2	Personnel Qualifications	7-2
7.2	Schematic Right-of-Way and Documents	7-2
7.3	DB Contractor Responsibilities.....	7-2
7.4	DB Contractor-Designated ROW Acquisition and Use	7-3
7.4.1	Description of Services	7-4
7.5	Mobility Authority Responsibilities.....	7-16
7.6	Submittals	7-17
8.0	UTILITIES.....	8-1
8.1	General Requirements	8-1
8.2	Referenced Standards and Guidelines	8-2
8.3	Information Provided by the Mobility Authority.....	8-3
8.4	General Description of Work.....	8-3
8.5	Utility Adjustment Team	8-4
8.6	Coordination and Cooperation with Utilities	8-5
8.6.1	DB Contractor Role	8-5
8.6.2	Failure of Utility to Cooperate	8-5
8.7	Meetings and Correspondence	8-5

8.7.1	Meetings with Utility Owners.....	8-5
8.7.2	Meetings Between Mobility Authority and DB Contractor	8-6
8.8	Verification of Utility Locations	8-6
8.8.1	DB Contractor’s Responsibility	8-6
8.8.2	Notification as to Newly Identified Utilities.....	8-6
8.8.3	Utility Tracking Report.....	8-7
8.9	Administrative Requirements	8-7
8.9.1	Standards.....	8-7
8.9.2	Real Property Matters	8-8
8.10	Agreements	8-9
8.10.1	Certain Components of the Utility Adjustment Work.....	8-9
8.10.2	Agreements Between DB Contractor and Utility Owners.....	8-10
8.10.3	Master Utility Adjustment Agreements	8-11
8.10.4	Utility Adjustment Agreement Amendments.....	8-11
8.11	Design Requirements.....	8-12
8.11.1	General Design Criteria	8-12
8.11.2	Utility Adjustment Plans.....	8-12
8.11.3	Plans Prepared by the DB Contractor.....	8-12
8.11.4	Plans Prepared by the Utility Owner.....	8-13
8.11.5	Design Documents.....	8-13
8.11.6	Certain Requirements for Underground Utilities	8-13
8.11.7	Utility Assemblies.....	8-13
8.12	Construction.....	8-16
8.12.1	General Construction Criteria	8-16
8.12.2	Inspection of Utility Owner Construction	8-16
8.12.3	Scheduling Utility Adjustment Work.....	8-16
8.12.4	Standard of Care Regarding Utilities	8-17
8.12.5	Emergency Procedures	8-17
8.12.6	Utility Adjustment Field Modifications	8-17
8.12.7	Switch Over to New Facilities	8-17
8.12.8	Record Drawings	8-18
8.12.9	Maintenance of Utility Service	8-18
8.12.10	Traffic Control	8-18
8.13	Submittals	8-18
8.13.1	Maximum Number of Submittals	8-18
8.13.2	Utility Assembly Submittals	8-19
8.13.3	FHWA Federal Procedure	8-20
8.14	Submittals	8-20
9.0	ENVIRONMENTAL COMPLIANCE	9-1
9.1	General	9-1
9.2	Environmental Approvals.....	9-7
9.2.1	Mobility Authority-Provided Approvals.....	9-7
9.2.2	DB Contractor Responsibility for Obtaining Environmental Approvals.....	9-7

9.2.3	Coordination Between The DB Contractor, The Mobility Authority and Regulatory Agencies.....	9-9
9.3	Performance Requirements.....	9-10
9.3.1	Environmental Mitigation Guidelines.....	9-10
9.3.2	Hazardous Materials Requirements	9-10
9.3.3	Noise/Sound Abatement Requirements	9-14
9.3.4	Air Quality Mitigation	9-15
9.3.5	Wildlife and Vegetation.....	9-15
9.3.6	Cultural Resources.....	9-17
9.3.7	Water Quality.....	9-18
9.3.8	Groundwater Impacts and Requirements	9-20
9.3.9	Floodplain Encroachment	9-20
9.3.10	Jurisdictional Waters, Including Wetlands.....	9-20
9.3.11	Geology and Karst Features.....	9-21
9.3.12	Edwards Aquifer Rules	9-23
9.4	Environmental Monitoring and Reporting.....	9-23
9.4.1	General Monitoring/Reporting Requirements.....	9-23
9.5	Environmental Protection Training	9-26
9.5.1	Training Goals	9-26
9.5.2	Training Scope and Content.....	9-27
9.5.3	Participation and Responsibilities	9-28
9.5.4	Training Schedule	9-28
9.5.5	Training Documentation	9-29
9.6	Environmental Personnel.....	9-29
9.6.1	Environmental Personnel.....	9-29
9.6.2	Environmental Compliance Manager	9-30
9.6.3	ECI Responsibilities.....	9-32
9.6.4	Karst Species Specialist	9-32
9.6.5	Natural Resource Biologist	9-33
9.6.6	Project Geoscientist.....	9-34
9.6.7	Water Quality Specialist	9-34
9.6.8	Hazardous Materials Manager.....	9-35
9.7	Submittals	9-36
10.0	LANDSCAPE AND AESTHETICS.....	10-1
10.1	General Purpose	10-1
10.2	Aesthetic Matrix and Color Palette	10-3
10.3	Bridge Components.....	10-3
10.4	Retaining Walls.....	10-3
10.4.1	Abutment Walls.....	10-4
10.5	Traffic Barriers.....	10-4
10.6	Sound Walls.....	10-4
10.7	Overhead Sign Structures, Toll Gantries, and ITS.....	10-5

10.8	Shared Use Path	10-5
10.9	Aesthetic Lighting Fixture Standards	10-5
10.10	Typical Cross-street Intersection Conditions	10-5
10.10.1	Cleaning and Repair of Flat Work	10-5
10.10.2	Cleaning of Existing Retaining Walls	10-6
10.10.3	Cleaning of Existing Bridges	10-6
10.10.4	General Non-Vehicular Paving.....	10-7
10.10.5	ADA Accessible Route.....	10-7
10.11	Coatings and Textures	10-7
10.12	Drainage and Grading Aesthetics.....	10-7
10.13	Landscape	10-8
10.14	Preservation and Repair of Areas to be Preserved	10-10
10.14.1	Tree and Plant Preservation	10-10
10.14.2	Maintaining Existing Vegetation and Soils.....	10-10
10.15	Seeding Revegetation	10-12
10.16	Maintenance and Establishment Period.....	10-12
10.16.1	Mowing.....	10-13
10.16.2	Invasive Species Control.....	10-14
10.17	Submittals	10-17
11.0	ROADWAY DESIGN	11-1
11.1	General Requirements	11-1
11.2	Roadway Design Criteria.....	11-2
11.3	General Scope Requirements	11-2
11.4	Standards and Guidelines.....	11-2
11.5	Roadway Elements.....	11-3
11.5.1	Traffic Lanes.....	11-4
11.5.2	Driveways and Entrances.....	11-4
11.5.3	Traffic Barriers and Attenuators.....	11-5
11.5.4	Medians	11-6
11.5.5	Front Slopes and Back Slopes.....	11-6
11.5.6	Pedestrian Traffic and Crossings.....	11-6
11.5.7	Bicycle Facilities.....	11-7
11.6	Aesthetics Design Elements.....	11-7
11.7	Additional Requirements	11-8
11.7.1	Standard Design Plans	11-8
11.7.2	Surveying and Construction Staking.....	11-8
11.7.3	Submittals	11-8
12.0	BRIDGES & HIGHWAY STRUCTURES DESIGN.....	12-1
12.1	General	12-1
12.2	Standards and Guidelines.....	12-1
12.3	General Requirements	12-3

12.3.1	Drawing Format.....	12-3
12.3.2	Subsurface Investigations.....	12-5
12.4	Bridge Design Requirements	12-5
12.4.1	General Requirements.....	12-5
12.4.2	Beams and Girders.....	12-9
12.4.3	Foundation Design.....	12-9
12.4.4	Bridge Bearings	12-10
12.4.5	Bridge Railing and Barriers	12-10
12.4.6	Accommodation of Ultimate Design	12-11
12.5	Retaining Walls.....	12-11
12.6	Drainage Structures	12-14
12.7	Structural Sign Supports	12-14
12.8	Other Bridge Structures	12-15
12.9	Existing Bridge Structures	12-15
12.10	Submittals	12-16
13.0	PERMANENT SIGNING DESIGN.....	13-1
13.1	Referenced Standards and Guidelines	13-1
13.2	Performance Requirements.....	13-1
13.3	Roadway Sign Design Criteria.....	13-2
13.3.1	Existing Signs	13-2
13.3.2	Sign Construction and Placement	13-3
13.3.3	Maintenance During Construction.....	13-4
13.4	Guide Sign Design Criteria.....	13-4
13.5	Advance Toll Sign Design Criteria	13-5
13.6	Third Party Signs.....	13-5
13.7	Signing Reports and Plans	13-5
13.7.1	Permanent Signing Concept Report.....	13-5
13.7.2	Permanent Signing Plans	13-7
13.8	Submittals	13-8
14.0	GEOTECHNICAL DESIGN REQUIREMENTS.....	14-1
14.1	Standards and Guidelines.....	14-1
14.2	Subsurface Investigation.....	14-2
14.2.1	General Requirements.....	14-2
14.2.2	Review and Inspection.....	14-3
14.2.3	Foundation Soil Borings	14-4
14.2.4	Standard Penetration Tests.....	14-5
14.2.5	Texas Cone Penetration Test.....	14-5
14.2.6	Soil Sampling.....	14-5
14.2.7	Rock Core Drilling.....	14-5
14.2.8	Borehole Sealing and Cleanup.....	14-5
14.2.9	Field Boring Logs	14-6

14.3	Laboratory Soil Tests	14-7
14.3.1	Soil Classification	14-7
14.3.2	Laboratory Tests	14-8
14.3.3	Final Boring Log.....	14-9
14.4	Geotechnical Analysis and Design.....	14-10
14.4.1	Geotechnical Reports.....	14-10
14.5	Geotechnical Field Instrumentation	14-14
14.6	Settlement Damage to Adjacent Properties	14-15
14.7	Vibration Monitoring and Control	14-15
14.7.1	Notification.....	14-16
14.7.2	Preconstruction Survey	14-16
14.7.3	Vibration Controls	14-19
14.7.4	Monitoring of Vibrations	14-19
14.8	Submittals	14-21
15.0	DRAINAGE DESIGN.....	15-1
15.1	Standards and Guidelines.....	15-1
15.2	Drainage Analysis and Evaluation	15-2
15.2.1	Data Collection for Drainage Design.....	15-3
15.2.2	Hydrology Analyses and Design.....	15-4
15.3	Design and Construction Criteria.....	15-6
15.3.1	Specific Requirements	15-6
15.3.2	General Purpose Lanes, Ramps, Collector Distributers and Direct Connector Drainage.....	15-9
15.3.3	Frontage Road Drainage	15-9
15.3.4	City and County Cross-Streets Drainage (Minor Collectors).....	15-9
15.4	Conveyance System Design.....	15-10
15.4.1	Design Criteria.....	15-10
15.4.2	System Material.....	15-11
15.4.3	Outlet Protection.....	15-11
15.4.4	Outfall Channel Improvements.....	15-12
15.5	Bridge Hydraulics	15-12
15.6	Open Channels and Ditches	15-12
15.7	Stormwater Management System.....	15-14
15.7.1	Detention and Water Quality Design	15-14
15.7.2	Underground Systems.....	15-16
15.8	Stormwater Pollution Prevention Plan (SW3P)	15-16
15.9	Water Resources Permits.....	15-16
15.10	Coordination of Water Resources Issues	15-17
15.11	As-Built Drainage Plans	15-17
15.12	Submittals	15-18
16.0	PAVEMENT MARKINGS	16-1

16.1	Referenced Manuals, Standards, and Guidelines	16-1
16.2	General	16-1
16.3	Pavement Marking Materials	16-2
16.3.1	Permanent Pavement Markings	16-2
16.3.2	Interim Pavement Markings.....	16-3
16.4	Submittals	16-3
17.0	TRAFFIC SIGNALS.....	17-1
17.1	Permanent and Temporary Signal Requirements.....	17-2
17.1.1	DB Contractor Responsibilities.....	17-2
17.1.2	Obtaining Equipment.....	17-4
17.2	Other Requirements.....	17-4
17.3	Design Plan Requirements.....	17-5
17.4	Submittals	17-5
18.0	DUCT BANKS & INTELLIGENT TRANSPORTATION SYSTEMS.....	18-1
18.1	Introduction.....	18-1
18.2	Maintenance of ITS During Construction.....	18-2
18.3	Duct Bank	18-2
18.3.1	Restoration of ITS Network.....	18-4
18.4	Mobility Authority CCTV Cameras.....	18-5
18.5	TxDOT CCTV Cameras	18-5
18.6	Mobility Authority Dynamic Message Signs.....	18-8
18.7	TxDOT Dynamic Message Signs.....	18-9
18.8	Barrier Mounted Gates	18-10
18.9	Mobility Authority Vehicle Detectors	18-10
18.10	TxDOT Vehicle Detectors	18-10
18.11	Roadside Communication Units.....	18-11
18.12	Electrical Services	18-11
18.13	Communication with Traffic Management Center.....	18-12
18.14	ITS Detailed Requirements.....	18-12
18.14.1	TxDOT Equipment/Systems.....	18-14
18.14.2	Inductive Detection Loops.....	18-16
18.14.3	License Plate Recognition System	18-16
18.14.4	Equipment Cabinet	18-16
18.14.5	Plan and Detail Sheets.....	18-16
18.14.6	Mounting Hardware.....	18-16
18.15	Submittals	18-17
19.0	LIGHTING	19-1
19.1	Referenced Manuals, Standards, and Guidelines	19-1
19.2	Lighting Requirements	19-1
19.2.1	Permanent Lighting.....	19-2

19.2.2	Temporary Lighting.....	19-5
19.3	Lighting Aesthetic Requirements.....	19-5
19.4	Lighting Roll Plot.....	19-6
19.5	Lighting Plans	19-7
19.6	Project Records	19-8
19.7	Submittals	19-10
20.0	PAVEMENT	20-1
20.1	General Requirements	20-1
20.2	Pavement Materials and Construction Requirements.....	20-1
20.2.1	Express and General Purpose Lane Widening Pavement and Structural Section Requirements.....	20-1
20.2.2	Loop 1 Express Lane and General Purpose Lane Widening and Structural Section Requirements	20-2
20.2.3	Frontage Road Pavement and Structural Section Requirements	20-3
20.2.4	Loop 1 Frontage Road Widening and Structural Section Requirements.....	20-4
20.2.5	Shared Use Path Pavement and Structural Section Requirements.....	20-4
20.2.6	Subgrade.....	20-4
20.2.7	Embankment.....	20-6
20.3	Pavement Texture.....	20-7
20.4	Pavement Testing.....	20-7
20.5	Submittals	20-11
21.0	TOLL SYSTEM	21-1
21.1	DB Contractor Responsibilities.....	21-1
21.2	Tolling Facilities	21-2
21.2.1	Subgrade Infrastructure.....	21-3
21.2.2	At-Grade Infrastructure.....	21-4
21.2.3	Above Grade Structures for Electronic Toll Collection (ETC) System.....	21-5
21.3	Toll Systems	21-6
21.4	DB Contractor’s Coordination Responsibilities with System Integrator.....	21-7
21.5	Submittals	21-11
22.0	MAINTENANCE OF TRAFFIC.....	22-1
22.1	General Requirements	22-1
22.2	MOT Plan	22-1
22.2.1	Development of MOT Plan.....	22-1
22.2.2	Items in MOT Plan	22-2
22.2.3	MOT Design Criteria.....	22-3
22.2.4	MOT Plan Implementation.....	22-5
22.3	Traffic Analysis Techniques and Software.....	22-5
22.3.1	VISSIM Modeling.....	22-5
22.4	MOT Staff.....	22-9
22.4.1	Traffic Control Engineer.....	22-9

22.4.2	Traffic Control Supervisor	22-10
22.4.3	Traffic Simulation Modeler.....	22-11
22.4.4	Local Traffic Control Crew.....	22-13
22.4.5	MOT Task Force	22-13
22.5	Lane Closures.....	22-14
22.5.1	General.....	22-14
22.5.2	Restricted Dates and Times.....	22-14
22.5.3	Detours.....	22-18
22.5.4	Lane Closure Notices.....	22-19
22.5.5	Traffic Switches	22-20
22.6	Traffic Control Devices	22-21
22.6.1	Temporary Guardrail, Concrete Traffic Barriers, and Attenuators.....	22-22
22.6.2	Signage	22-22
22.6.3	Pavement Markings	22-23
22.6.4	Lighting	22-24
22.6.5	Signals	22-24
22.7	Miscellaneous	22-25
22.7.1	MOT Compliance, Suspension, and Liquidated Damages.....	22-25
22.7.2	Emergency Response.....	22-25
22.7.3	MOT Safety	22-26
22.7.4	Courtesy Patrol	22-27
22.8	Submittals	22-29
23.0	CONSTRUCTION	23-1
23.1	Construction Specifications	23-1
23.1.1	Specific Specification Modifications	23-1
23.1.2	Materials on Site	23-2
23.1.3	Stockpiles.....	23-2
23.1.4	Foundation Load Tests.....	23-3
23.2	House Keeping.....	23-3
23.2.1	Protection of Surface Waters and Flood Plains	23-3
23.2.2	Drainage Facilities	23-4
23.2.3	Maintenance of Right-of-Way	23-4
23.2.4	Protection and Restoration of Property and Landscape.....	23-4
23.2.5	Pedestrian Access & Recreational Trails	23-5
23.3	Construction Documentation	23-5
23.4	Construction Operations	23-5
23.5	Surveying and Construction Staking	23-7
23.5.1	General.....	23-7
23.5.2	Reference Documents	23-7
23.5.3	Performance Requirements.....	23-7
23.6	Video Inspection of Drainage System	23-9
23.7	Project Segments.....	23-10

23.7.1	Design Requirements.....	23-10
23.7.2	Environmental Requirements.....	23-11
23.7.3	Utilities.....	23-11
23.7.4	Right-of-Way.....	23-11
23.7.5	Project Schedule and Schedule of Values.....	23-11
23.8	Submittals.....	23-12
24.0	MAINTENANCE	24-1
24.1	General Requirements	24-1
24.2	General Maintenance Requirements.....	24-3
24.3	Limitations of Operations	24-4
24.4	Submittals	24-4
25.0	SAFETY PLAN	25-1
25.1	General Requirements	25-1
25.2	Submittals	25-2
26.0	SUSTAINABILITY.....	26-1
26.1	INVEST Project Type and Module.....	26-1
26.2	Required INVEST Achievement Level for Project.....	26-1
26.3	Pre-Scoring Workshop	26-1
26.3.1	Pre-Scoring Workshop Preparation.....	26-1
26.4	Reporting	26-2
26.5	Awards and Incentives Associated with INVEST Achievement Levels	26-2
26.5.1	INVEST Silver Achievement Level Project	26-2
26.5.2	INVEST Gold Achievement Level Project.....	26-2
26.5.3	INVEST Platinum Achievement Level Project	26-2
26.6	Effects on Price and Schedule.....	26-2
26.7	Personnel and Staffing.....	26-3
26.8	Submittals	26-3

Attachments

Attachment 5-1	WBS Minimum Requirements
Attachment 5-2	SOV Structure for Cost Reporting
Attachment 6-1	UPRR Scope of Work
Attachment 10-1	US 183 North Mobility Project Aesthetic Design Guide
Attachment 11-1	Design Criteria Summary-Project Roadways
Attachment 12-1	Bridge Condition Rating Summary
Attachment 15-1	Impact Assessment Evaluation Requirements
Attachment 21-1	Toll Facility and ITS Responsibility Matrix
Attachment 21-2	Toll System Installation Dependency Matrix

1.0 PROJECT ADMINISTRATION AND MANAGEMENT

1.1 Introduction

The DB Contractor shall be responsible for developing, implementing, and maintaining the Project Management organization and system in accordance with the requirements identified in this *Technical Provision 1*.

The DB Contractor shall perform all Work in cooperation with the Mobility Authority and in a manner consistent with the following primary management goals and in accordance with the requirements of the Contract Documents:

- Schedule certainty.
- Maintain mobility during construction.
- Minimize impacts to local businesses.
- Effective communication of closures and delays.
- Quality in design and construction.

1.1.1 General Requirements

The DB Contractor Responsibilities. The DB Contractor shall:

- Manage and administer the planning, execution, and control of all aspects of the Project, including coordinating all activities required to complete the Project in accordance with the Contract Documents.
- Coordinate its activities with the Mobility Authority, members of the DB Contractor team, Governmental Entities, and other entities that are directly or indirectly impacted by the Project.
- Document and report the Project activities and progress in accordance with the requirements of the Contract Documents.
- As required, resubmit documents in a timely manner and incorporate the resubmittals in the Project Schedule to document any possible schedule impacts.

Management Approach. The DB Contractor's management approach shall provide all components of an effective and efficient management system, including (but not limited to):

- Communication and reporting.
- Documentation of the Project.

- Create and update monthly a comprehensive critical-path method schedule reflecting the Project status.
- Supervision of Project personnel and activities.
- Procurement and the effective utilization of all tools, facilities, services, and materials.
- Environmental compliance, protection, and mitigation.
- Safety of Project personnel, motorists, and the general public.
- Any other management elements needed to produce and document a high-quality, safe, efficient, and operable Project that minimizes environmental impacts.

Working Together. Communications shall be open between the Mobility Authority and the DB Contractor, and both parties shall continually work together towards Project betterment. The staff at all levels shall continually seek opportunities to improve efficiency, and at the same time meet the goals and requirements of the Contract Documents. The DB Contractor shall empower all levels of its organization to meet Project goals and the DB Contractor’s obligations.

1.1.2 Project Management Plan

The DB Contractor shall submit a detailed Project Management Plan (PMP) to the Mobility Authority for acceptance as a condition for issuance of NTP2. The PMP shall update and expand upon the preliminary PMP contained in the DB Contractor’s Proposal.

The PMP shall set out the DB Contractor’s management approach to design, construction, and public involvement. It shall contain the DB Contractor’s plan for executing the Project and related contract administration. The PMP shall clearly illustrate the DB Contractor’s capability to:

- Control, coordinate, and manage Subcontractors, sub-consultants, suppliers and other resources.
- Interface with the Mobility Authority, its consultants and third parties.
- Control and manage the costs and schedules of the Project.
- Comply with applicable Law.
- Provide the experienced personnel, facilities, and resources required to successfully complete the Project.
- Maintain stakeholder support via community outreach.
- Address the critical elements and success factors.

1.1.3 Key Personnel

1.1.3.1 Key Personnel Positions

Key Personnel are the persons in the DB Contractor's organization who are responsible for the following particular Project functions:

Category A:

- Project Manager
- Design Manager
- Construction Manager
- Project Scheduler
- Design Quality Assurance Manager (DQAM)
- Construction Quality Assurance Manager (CQAM)
- Traffic Control Engineer
- Environmental Compliance Manager (ECM)

Category B:

- Utilities Manager
- Safety Manager
- Senior Geotechnical Engineer
- Senior Design Engineer—Structures
- Senior Design Engineer—Roadways
- Senior Design Engineer—Drainage
- Civil/Utility Engineer (CUE)
- Project Superintendent
- Structures Superintendent
- Paving Superintendent
- Grading Superintendent
- Construction Quality Control Manager (CQCM)
- Senior Construction Inspector – Roadway (QC)
- Senior Construction Inspector – Structures (QC)

Senior Construction Inspector – Traffic (QC)
Senior Construction Inspector – Utilities (QC)
Senior Construction Inspector - Drainage (QC)
Senior Construction Materials Testing Superintendent (QC)
Community Relations Specialist (CRS)
Architect
Traffic Simulation Modeler

Co-location requirements for this Project are:

- **All** Category A Key Personnel and Category B Key Personnel, unless agreed to by the Mobility Authority in writing, shall be located at the main Project office for the duration of their assignment.
- While the Mobility Authority views the co-location of the Project Design team in the main Project office as a benefit to the Project, the design support staff such as designers, engineers, and drafters are not required to be located at the Project Office during design efforts. However, during the design and construction of the Project, these personnel may need to be located at the Project Office for periods of time for design reviews and to address Project design/construction issues.

DB personnel shall be available as necessary to respond to project requirements, irrespective of their location. Timely response is required to avoid any impacts to project delivery or to Mobility Authority, TxDOT, or FHWA review times.

With prior written consent from the Mobility Authority, the DB Contractor may designate one individual to perform the function of a maximum of two Key Personnel positions.

1.1.3.2 Qualifications and Mobility Authority Approval

Qualifications. Key Personnel shall have the following qualifications:

- Experience in his or her appropriate field.
- A work history relevant to the assigned area of Project responsibility.
- The appropriate professional licenses and certifications.

The Project Scheduler must have a Project Management Institute Scheduling Professional (PMI-SP) certification or an Association for the Advancement of Cost Engineering (AACE) Planning and Scheduling Professional (PSP) certification within three months after NTP1 or prior to issuance of NTP2.

At a minimum, the following Key Personnel shall be Registered Professional Engineers within three months after NTP 1 or prior to issuance of NTP 2:

- Design Manager
- Design Quality Assurance Manager (DQAM)
- Senior Geotechnical Engineer
- Senior Design Engineer, Structures
- Senior Design Engineer, Roadways
- Senior Design Engineer, Drainage
- Traffic Control Engineer
- Civil/Utility Engineer (CUE)
- Traffic Simulation Modeler

Senior Design Engineers. The DB Contractor shall designate the Senior Design Engineer(s) (engineer[s] in responsible charge) for each technical item or element of the Project. The Senior Design Engineer shall be a Registered Professional Engineer with at least 15 years of experience. The Senior Design Engineer may have less than 15 years of experience with prior written approval from the Mobility Authority. The Senior Design Engineer is personally responsible for directly supervising the Project Design and who will certify, sign, and date all design plans, reports, and submittals for a given technical item or element of the Project.

1.1.3.3 Directory and Organization Chart

Key Personnel Directory. Within 30 Business Days after issuance of NTP 1, the DB Contractor shall submit to the Mobility Authority a directory that contains the following information for each Key Personnel: name, title (with respect to the Project), Project office address and location, e-mail address, and telephone numbers (office, home, and cellular). The directory shall be kept current throughout the course of the Project and resubmitted to the Mobility Authority within 3 Business Days of a change in Key Personnel.

Organization Chart. The DB Contractor shall provide to the Mobility Authority as part of the Project Management Plan (PMP) a Project organization chart that graphically represents the hierarchy and functional interaction of the Key Personnel, and indicates the functional responsibilities of each. The organization shall be monitored and the chart updated and provided to the Mobility Authority when changes to the DB Contractors' organization chart occur.

1.1.4 Communication and Partnering

DB Contractor Responsibility. The DB Contractor shall establish the communication systems necessary to control all facets of the Project and maintain communications with the Mobility Authority, local

stakeholders and Governmental Entities that have review and approval authority on the Project, including local and regional emergency response agencies or entities, per the requirements of the Contract Documents.

1.1.4.1 *Coordination Meetings*

Weekly Meetings. The DB Contractor shall meet weekly with the Mobility Authority to discuss and coordinate the Project progress, issues, and planned Work for all Project phases, including design, right-of-way (ROW) acquisition, utilities relocation, permits and agreements, environmental compliance, and construction. The DB Contractor and the Mobility Authority will jointly develop the agenda. The DB Contractor shall provide the meeting facilities unless directed otherwise by the Mobility Authority. The DB Contractor shall keep minutes of each coordination meeting and, within 2 Business Days, distribute copies marked as “DRAFT” to Mobility Authority participants for their review and comments. Upon receipt of Mobility Authority comments, the DB Contractor shall prepare final minutes and distribute copies to all participants within 1 Business Day.

Other Meetings. In addition to the weekly meetings, the DB Contractor and the Mobility Authority will meet as needed to discuss Project-related issues. The DB Contractor will also attend monthly long-term strategy meetings with the Mobility Authority. The DB Contractor shall keep minutes of each meeting and, within 2 Business Days after the meeting, distribute copies marked as “DRAFT” to Mobility Authority participants for their review and comments. Upon receipt of Mobility Authority comments, the DB Contractor shall prepare final minutes and distribute copies to all participants within 1 Business Day.

The DB Contractor’s Project Manager shall prepare for and participate in Mobility Authority Board of Directors Meetings to present Project status as requested by the Mobility Authority.

1.1.4.2 *Monthly and Weekly Reports*

Detailed reporting requirements for the Project are described in various sections of the Contract Documents.

1.1.4.3 *Project Partnering*

The Mobility Authority requires the use of partnering principles on this Project. A formal dispute resolution procedure shall be included in the PMP to assist in resolving any disagreements quickly and keep the Project moving forward on schedule. In the event partnering fails to resolve an issue and the DB Contractor elects to pursue a formal dispute with the Mobility Authority, the dispute shall be resolved using the procedures, methods, and decision body provided by Section 25 of the DB Agreement.

Attendees. All Category “A” Personnel listed on the DB Contractor’s organizational chart, representatives from any major Subcontractor scheduled to work on the Project, and key personnel from the Mobility Authority and the Mobility Authority’s GEC. Other attendees the Mobility Authority may elect to invite may include representatives from TxDOT, FHWA, representatives from Utility and Railroad companies involved with the Project, and other third parties.

Initial Workshop. The DB Contractor shall initiate a 1 day facilitated workshop to set the process in motion and shall be held prior to the start of design. The content of the workshop will be determined cooperatively by the DB Contractor and the Mobility Authority. The workshop shall provide coffee breaks and lunch for the participants.

Additional Quarterly Executive Partnering Workshops. The DB Contractor shall plan and hold half day workshops quarterly with Category A personnel, Mobility Authority, TxDOT, and FHWA. The content of the workshop will be determined cooperatively by the DB Contractor and the Mobility Authority.

Additional Full Team Partnering Workshop. The DB Contractor shall plan and hold a 1 day workshop to also include Category B personnel. The content and schedule of the workshop will be determined cooperatively by the DB Contractor and the Mobility Authority. The workshop shall provide coffee breaks and lunch for the participants.

The partnering facilitator shall be an independent impartial third party, not representing either the Mobility Authority or the DB Contractor. The DB Contractor and the Mobility Authority shall jointly hire and pay the partnering facilitator. Each party shall pay 50% of the costs of the partnering facilitator. The DB Contractor shall provide the Mobility Authority the resume of their proposed partnering facilitator no less than 20 Business Days prior to the workshops for approval by the Mobility Authority.

Costs. All costs of providing the partnering workshop(s), excluding the partnering facilitator, shall be paid by the DB Contractor.

1.1.4.4 Toll and ITS Site Turnover Coordination

Upon the completion of construction at each toll and ITS site owned by the Mobility Authority, the DB Contractor shall coordinate with the SI and Mobility Authority to review the constructed infrastructure prior to acceptance of each site by the Mobility Authority. The DB Contractor shall include in their PMP a detailed process for coordination communication and turnover coordination. A site shall not be considered complete until it is accepted by the Mobility Authority.

1.1.5 DB Contractor Subcontracts

Subcontracting Plan. Within 20 Business Days after issuance of NTP 1, the DB Contractor shall provide the Mobility Authority its proposed Subcontracting Plan. The Mobility Authority will review the plan for consistency with the Mobility Authority's requirements regarding Subcontracts and its disadvantaged business enterprise (DBE) policy, and then provide comments. The DB Contractor shall promptly incorporate the Mobility Authority's comments into the Subcontracting Plan and comply therewith. The approved Subcontracting Plan shall be updated monthly to reflect any changes to the DB Contractor Subcontract agreements and submitted to the Mobility Authority for review. If no changes to the Subcontracting Plan have occurred, then the DB Contractor shall so state in its monthly progress report to the Mobility Authority.

As a minimum, the Subcontracting Plan shall include the DB Contractor's DBE Policy, Commitment and Program to meet their commitment along with a listing of each Subcontractor's Name, Address, Phone Number, Contact Person, Scope of Work, Price or Fee, and DBE status.

Coordination. The DB Contractor shall be solely responsible for scheduling and coordinating the Work of Subcontractors, suppliers, Utility Owners, and other individuals or entities performing or furnishing any of the Work under a direct or indirect contract with the DB Contractor.

1.2 Facilities, Office Space, and Equipment

1.2.1 General Requirements

DB Contractor Responsibilities. The DB Contractor shall:

- Provide and pay for all office and working space, facilities, equipment, services, and vehicles necessary for the DB Contractor to manage, coordinate, and administer the design, construction, and maintenance of the Project in accordance with the Contract Documents.
- Maintain the main Project office facilities for at least 60 days after Final Acceptance, or until otherwise agreed to by the Mobility Authority in writing.
- After Final Acceptance, provide disposal or removal of all facilities. Restore and revegetate in accordance with Technical Provision 10, unless otherwise approved by the Mobility Authority.

Main Project Office. The DB Contractor shall establish a main Project office and locate its Key Personnel, as required by this Technical Provision 1.1.3.1, in that office.

Main Project Office Location. The main Project office shall be located within a 2-mile radius of the Project. With Prior written approval from the Mobility Authority, the main Project office may be located greater than 2 miles from the Project. The Main Project Office shall not be located within the project Right of Way.

Location of Design Firm. The Mobility Authority views the co-location of the Project Design team in the main Project office as a benefit to the Project. If the DB Contractor performs a portion or all of the Project Design outside of the main Project office, the DB Contractor's PMP shall address the unique challenges associated with performing design off site.

1.2.2 Mobility Authority Project Office Space

Mobility Authority Project Office. The DB Contractor shall develop, in coordination with the Mobility Authority, a Project office layout that promotes daily communication and partnering. There shall be no separated portion of the main Project office designated specifically for the Mobility Authority staff; rather the required Mobility Authority offices, cubes, and equipment as indicated in this Technical Provision 1.2 shall be co-mingled within the DB Contractor's space. Mobility Authority offices, enclosed file/storage rooms, and server room shall be lockable.

Mobility Authority Project Office Space Deadline. The DB Contractor shall provide the Mobility Authority Project office space, meeting the requirements of this *Technical Provision 1.2* within 30 Business Days after issuance of NTP 1.

Mobility Authority Approval. The location, condition, furniture, and amenities of the Mobility Authority Project office are subject to the Mobility Authority's prior written approval.

Mobility Authority Project Office Condition. The office facilities, furniture, and equipment for the Mobility Authority shall be provided by the DB Contractor and shall be in good and serviceable condition (at least of the same quality as those of the DB Contractor's main Project office). Both parties shall participate in a facility condition survey prior to and at the completion of occupancy. The Mobility Authority will return possession of the DB Contractor-provided facilities to the DB Contractor in essentially the same condition as when the Mobility Authority first occupied the facilities, except for reasonable wear and tear and except for alterations, loss, or damage caused by the DB Contractor.

Mobility Authority Project Office Space Requirements. The DB Contractor shall, as part of the Project:

- Secure a well-graded site that has an access road, a parking area, and building space that meets all local building code requirements.
- Obtain all site permits.
- Provide all utility services.
- Provide a Mobility Authority parking area for at least 30 vehicles that is reasonably level and has an all-weather surface and all-weather access.
- Provide at least two building entrance/exits, each secured with a door lock plus a dead-bolt lock.
- Ensure that the site and main Project office facilities meet all access requirements of the Americans with Disabilities Act (ADA), as amended (42 USC §§12101, *et seq.*).

Mobility Authority Field Offices. If the DB Contractor's construction office is not at the main Project office, the DB Contractor shall provide a separate fully furnished office for the Mobility Authority, in a configuration approved by the Mobility Authority. This facility shall serve as a Mobility Authority field office and shall be located in close proximity to the DB Contractor's construction office. The DB Contractor shall not use Project Right-of-Way to provide for either its project office or Mobility Authority office spaces.

The DB Contractor shall also provide a separate office for the Mobility Authority, in a configuration approved by the Mobility Authority, at the Asphaltic Concrete Production site. This facility shall serve as an Asphalt Mix Control Laboratory. This Laboratory will generally comply with Item 504 – Type C Structure (Asphalt Mix Control Laboratory) for Construction Inspectors as specified in the TxDOT

Standard Specifications for Construction and Maintenance of Highways, Streets, and Bridges, adopted by TxDOT in November 2014 including a dedicated T-1 telephone line for the Mobility Authority's sole use.

1.2.3 Mobility Authority Project and Field Office Services and Systems

Office Services and Systems Requirements. For all offices provided by the DB Contractor, the DB Contractor shall provide and pay for:

- Potable water and sewer service, including functional hot and cold water faucets.
- Bottled drinking water service.
- Electricity service and interior overhead lighting that meet Occupational Safety and Health Administration (OSHA) standards and building and electrical code requirements for office space, with minimum electrical circuit capacity of 20 amperes and with at least two duplex electrical receptacles in each personal office area.
- Heating, ventilation, and cooling systems capable of maintaining temperatures between 65 and 70 degrees Fahrenheit in all spaces throughout the year.
- Daily janitorial service (except on Saturdays, Sundays and Holidays), including maintenance of trash containers and trash pickup service.
- Maintenance of the exterior areas, including the access to parking areas, that keeps them neat, clean, in good repair, and safe.
- Exterior security lighting that is automatically activated at low light levels to maintain at least 2-foot candles of lighting within the fenced office site.
- Dedicated telephone lines for the Mobility Authority's sole use, including monthly service charges
- Telephone service with at least one outside line (with voice-mail service) for each person assigned to the office.
- 20 Megabyte/sec, at a minimum, synchronous transfer rate business class Ethernet system. Hardware shall be provided by TxDOT approved vendors or equivalent.

1.2.4 Mobility Authority Office Space Requirements

Office Space Requirements. The Mobility Authority Project office space provided by the DB Contractor, inclusive of space at the main Project office, shall include the following elements:

- Eight enclosed offices (of at least 225 square feet each).
 - These offices shall be located at the main Project office.
- Twenty cubicles (of at least 100 square feet each).

- If the DB Contractor's construction office is not at the main Project office, 16 cubicles shall be located at the main Project office and 8 cubicles shall be located at the Mobility Authority field office.
- One enclosed conference room (of at least 400 square feet).
- One enclosed conference room (of at least 200 square feet) for the Mobility Authority's sole use.
- One secure server room (of at least 6 x 9 feet) for the Mobility Authority's sole use with supplemental AC if internal AC cannot keep the room at or below 75 degrees at all times. This room shall be no further than 300 feet from the farthest cube/office. Electrical in the server room shall consist of two 20-AMP 120V circuits with 2 National Electrical Manufacturers Association (NEMA) 5-15 and 1 NEMA 5-20 outlet on each circuit.
- Two lockable enclosed spaces for storage/filing (combined areas, at least 150 square feet).
- An enclosed lockable space for storage of equipment (of at least 150 square feet).
- Cell phone service acceptable to the Mobility Authority.
- Two restrooms (one each for men and women) that include toilets and sinks (sized appropriately for an office of 20 people) and continuously stocked with tissue, toweling, soap, and other supplies typical of such facility.
- A combination break and lunch room area with sink, refrigerator, and microwave (of at least 200 square feet).

1.2.5 Mobility Authority Office Equipment

The DB Contractor shall provide, install, and maintain the following equipment (in working order) for the Project and field offices, including paper and toner.

1.2.5.1 Specific Requirements for Fax, Copiers, and Printers

Multi-Functional Printer Equipment for Project Office

The DB Contractor shall provide:

- A minimum of two high-speed color printer/photocopy machines capable of handling 11x17 prints with scanner and email capabilities for Mobility Authority staff only and not to be shared with the DB Contractor or any other staff.
- Access to a full-scale plotter and color copier printer (may be shared with the DB Contractor if located in adjacent office space within the same building).

1.2.5.2 Loss or Damage to Mobility Authority Office(s)

DB Contractor Responsibility. If any the DB Contractor-provided office space, facility, or equipment is damaged, destroyed, or stolen during the Project duration, the DB Contractor shall (at its own expense, except as noted herein) repair it, replace it, and/or otherwise restore it to its original condition within 5 Business Days after the occurrence of such damage or loss.

If any DB Contractor-provided office space loses network connectivity, power, HVAC or copying/scanning capabilities, the DB Contractor shall repair or replace the capabilities at that location within 24 hours after the occurrence of such loss.

Mobility Authority Responsibility. If any loss or damage has been caused as a direct result of willful misconduct of Mobility Authority personnel or its consultant staff, the Mobility Authority will reimburse the DB Contractor for the actual, reasonable, and documented costs of the repair, replacement, and/or restoration prior to Final Acceptance.

1.3 Project Records

General Requirements. The DB Contractor shall be responsible for documentation of all Project activities.

Specific Requirements. This Technical Provision 1 is general in nature and applies to all Project activities. For specific documentation requirements related to a specific Project element, refer to the pertinent subsections of the Exhibit B – Scope of Work and Exhibit C – Technical Provisions.

Submittals Receipt Date. All submittals to the Mobility Authority received after 1:00PM on any Business Day will be stamped received the following Business Day.

1.3.1 Documentation Media

All Project files shall be maintained in the electronic medium using the software programs specified in Technical Provision 1.4.

1.3.2 Distribution of Communications

The DB Contractor shall prepare and circulate to the Mobility Authority and other appropriate parties electronic copies of all correspondence, minutes of meetings, and other external documents reflecting or constituting any and all communications with:

- The Mobility Authority
- TxDOT
- Utility Owners
- Railroads

- Communities
- Governmental Entities and regulatory agencies
- Businesses and Project stakeholders
- Landowners

1.3.3 Electronic File Backups

All electronic files shall be backed up daily. The backup tapes, USBs or other storage media shall be delivered weekly to a secure off-site storage area that has been approved in writing by the Mobility Authority. Electronic Data Management systems using Internet transfer and off-site storage may also be used with prior approval of the Mobility Authority.

1.3.4 Project Office Documentation

1.3.4.1 Design and Construction Communications and Submittals

Design Communications and Submittals

Main Project Office Files. The DB Contractor shall maintain at all times, at its main Project office, at least one complete organized set of all documents related to the design of the Project, including (but not limited to) the following items:

- Contract Documents and master agreements.
- Subcontracts.
- All other legal agreements and proceedings related to the Project or Work.
- All Manuals and Standards referenced in these *Technical Provisions*.
- Design calculations and analyses.
- Mix designs.
- Reports, studies, and investigations.
- Project Schedule.
- Monthly pay request documentation.
- Released-for-Construction plans, construction sketches, and diagrams.
- Soil boring logs, laboratory test results, QC records and audits, etc..
- Communications (includes all written communications, such as correspondence, transmittal and other forms, e-mail messages, facsimile transmissions).
- Minutes of meetings.

- Review comments from the Mobility Authority.
- Governmental Approvals.
- Change Orders and claims (including all related communications and disputes resolution proceedings).
- Insurance policies, correspondence, and terms.

Construction Communications and Submittals

Main Project Office Files. The DB Contractor shall maintain at its main Project office at all times, and make available for Mobility Authority review at any time, at least one complete organized set of all documents related to the construction and maintenance of the Project, including (but not limited to) the following items:

- Construction contracts.
- Subcontracts and supplier contracts.
- Change Orders and claims.
- Working drawings.
- Shop drawings.
- Pay requests.
- Minutes of meetings.
- Safety, injury, damage, and incident reports.
- Hazardous material manifests.
- Calculations.
- Reports.
- NCRs and RFIs.
- Tests.
- QC/QA records and audits.
- Drawings (two sets: one unmarked “clean” set, and one master copy set for Record Drawings control records).

Submittal Media. All design and construction communications, submittals and documentation (including in-process, final, and Record Drawings) shall be submitted to the Mobility Authority as both hard-copy printouts and electronic files, as indicated below.

Electronic Files. As a condition of the Final Acceptance, the DB Contractor shall deliver one complete electronic copy of all above-listed design and construction documents to the Mobility Authority for its retention and use at the completion of the Project. The detailed organization of the electronic files must be acceptable to the Mobility Authority. This submittal is to be complete and accurate and the DB Contractor cannot rely on previous submittals to supplement this requirement.

1.3.5 Document Control

Document Control. The DB Contractor shall establish and maintain an electronic document control system in accordance with this Technical Provision 1. Such system shall be compatible with the Mobility Authority system to allow sharing of documents. The system shall be able to export all documents, metadata and document index criteria into an aggregated spreadsheet or database file, which provides links to all of the project files with all associated metadata and index criteria available in the system. In general, the Mobility Authority uses Microsoft Office for document production and exchange.

Monthly Verification. The DB Contractor shall develop a monthly certification form (subject to the approval of the Mobility Authority) that verifies compliance with the Project document control standards and practices identified within these Contract Documents. As part of the draw request and Project certification, this certification will be completed monthly, signed by the Design Quality Assurance Manager and the Construction Quality Assurance Manager and submitted to the Mobility Authority for its review and validation of the DB Contractor's document control performance.

1.4 Computer Software Requirements

1.4.1 General Guidelines

DB Contractor Responsibilities. The DB Contractor shall acquire, use, and maintain all of the computer software as specified in this Technical Provision.

Versions. The DB Contractor shall use the current version of the specified software in effect as of NTP 1, unless specifically called out otherwise in this Technical Provision.

Updates. The DB Contractor shall update their software programs throughout the term of the DB Agreement within 6 months of release of a software update, unless otherwise mutually agreed to by the parties. Software updates shall receive prior approval from the Mobility Authority.

File Server. Data files for the applications included in this Technical Provision shall reside on the DB Contractor's file server.

1.4.2 Required Project Software

The DB Contractor shall use the software programs for the Project as specified below.

1.4.3 Drawing Production – Computer Aided Drafting and Design (CADD)

The DB Contractor shall use Bentley OpenRoads Designer CONNECT Edition.

1.4.4 Roadway Geometric Design

Software used by the DB Contractor for roadway geometric design shall be Bentley OpenRoads Designer CONNECT Edition.

1.4.5 Three-Dimensional (3-D) Design

The DB Contractor shall design the Project utilizing 3-D methodologies and techniques, and submit its 3-D design files to the Mobility Authority for use during the design and construction process.

Utilization of 3-D design is an integral part of the performance of the Project prior to and during construction and throughout the Project's service life. Additionally, the implementation of 3-D design techniques is intended to improve quality, reduce risk, improve collaboration with project stakeholders, provide an early focus toward technical review, and increase opportunity for innovation.

The DB Contractor shall utilize Bentley MicroStation Connect Edition with OpenRoads Designer to develop the 3-D design, unless the DB Contractor receives advanced written approval from the Mobility Authority.

1.4.6 3-D Design Requirements

The DB Contractor shall submit proposed 3-D design file and feature definitions naming conventions to the Mobility Authority for review and acceptance. Naming conventions shall be consistent with the TxDOT published workspace.

The DB Contractor shall incorporate relevant portions of the Mobility Authority Schematic Design into the DB Contractor's Project design files utilizing 3-D methodologies and techniques.

The DB Contractor shall create an integrated 3-D model of the existing condition including existing ground surface and subsurface elements and infrastructure (including, but not limited to, drainage structures, utilities, bridges and wall foundations), utilizing data from light detection and ranging (LiDAR), SUE, field surveys, and existing plans (as-built) data collection; including currently available LiDAR or other existing ground surface data (digital terrain model (DTM) or triangulated irregular network (TIN) formats) provided in the RID.

The DB Contractor shall utilize 3-D methodologies and techniques to develop the geometric design as well as the 3-D design model for each proposed roadway and incorporate it into the Project's integrated design models. All geometric design shall be prepared in accordance with the DB Scope of Work and Technical Provisions:

- Refine and finalize 3-D horizontal and vertical alignments for all managed lanes, general purpose lanes, ramps, direct connectors, collector-distributors, frontage roads, crossing and parallel roadways, pavement transitions, and tie-ins to existing lanes.
- Determine horizontal and vertical clearances at grade separations, underpasses and overpasses.
- Develop superelevation and superelevation transition designs for each roadway. Verify rollover constraints are adequately addressed, including ramp, collector-distributor, and direct connector gore locations.

The DB Contractor shall include proposed 3-D design features for the following Elements of Work in accordance with the Scope of Work and *Technical Provisions*:

- Roadway: pavement structures, concrete barriers, metal beam guard fence (MBGF), pedestrian facilities, existing and proposed ROW.
- Drainage: storm sewers (inlets, manholes), culverts, and channel grading.
- Structures: sufficient detail to show top of deck surface, structure type, bottom of beam surface, bent cap, piers, foundations (size and length), abutment, and retaining wall locations including straps, nails and footings.
- Additionally, the DB Contractor shall incorporate within the 3-D model sufficient level of detail for existing features to demonstrate design integration and coordination.

1.4.7 Immersive 3-D Review Meetings

The DB Contractor shall present the Project 3-D design model to the Mobility Authority and stakeholders at review meetings. The DB Contractor shall utilize software that allows for interactive visualization of the 3-D design model key features. The 3-D design model shall be completed to a sufficient level of detail that existing terrain, proposed design features, and existing infrastructure to remain in place can be viewed, analyzed, and discussed among participants. Review meetings shall occur prior to any design Submittals to the Mobility Authority.

The DB Contractor's 3-D design model shall be capable of providing the following minimum functionality during the immersive 3-D milestone review meetings:

- View the model and manipulate view settings to interactively change data display on the screen (e.g. pan, rotate, walk, fly, zoom, etc.).
- Measure distances and areas throughout all areas of the model.
- Reference baseline geometry, stationing, and existing and proposed ROW.
- Dynamically visualize key existing and proposed design features and detect conflicts/clashes amongst the following disciplines:
 - Roadway.

- Drainage.
- Structures (bridges, retaining walls).
- Utilities (existing and proposed).
- Signing (overhead span or cantilever sign structure locations and structure type).
- Lighting (pole and foundation locations).
- Signals (controller, pole, and foundation locations).
- Toll infrastructure.
- Temporary structures.

The DB Contractor shall submit the following before every review meeting:

- Adobe PDF file of Project 3-D model which shall include proposed striping.
- All CADD and other electronic files used to develop the 3-D model along with all associated files required to duplicate the model.
- Updated Utility Adjustment Concept Plan.

1.4.8 3-D Design Deliverables

Integrated design model deliverables shall consist of 3-D MicroStation file(s) containing 3-D graphical elements (components, contours, superelevation transitions limits, and existing and proposed finish grade triangles) representative of the entire proposed project. Additional electronic design files to be submitted to the Mobility Authority by the DB Contractor include:

- OpenRoads: MicroStation design files containing civil data of alignments, profiles, pertinent geometry, terrain surfaces, civil cells, corridor models and final surface. In addition to other MicroStation elements used in the creation of the corridor model such as point controls, corridor references, etc..
- InRoads template library (ITL): OpenRoads Template Libraries.
- XML: Output files of alignments, profiles, pertinent geometry, DTM for terrain surface and final surfaces.
- Drawing exchange format (DXF): Output files of DTM for terrain surfaces and final surfaces.
- Infrastructure Consensus Model (ICM) output files in a rich data exchange format using Bentley i-model standards. The ICMs will be used to transfer the 3-D model information to construction equipment.
- DTM data:
 - GEOPAK original ground TIN file, or Digital Terrain Model (DTM) file as appropriate

- Preliminary design surfaces.
- Final design surface.

Preliminary design surfaces refer to surfaces in preliminary design state but not final, which are part of a surface model that represents the Project's existing and proposed terrain features.

Additionally, the DB Contractor shall submit electronic construction i-models compatible with the DB Contractor's construction equipment. The i-models will be utilized by the Mobility Authority to verify grading operations of subgrade and the final pavement surface, as well as construction of storm sewer systems and culverts.

1.4.9 Drainage Design

Software shall be as proposed by the DB Contractor, subject to approval of the Mobility Authority and any appropriate regulatory agencies. The software packages and technical advisories pre-approved by the Mobility Authority are:

- StormCAD for OpenRoads (SUDA)
- HEC-HMS
- HEC-RAS
- HY-8
- SCS TR-55
- EPA SWMM

1.4.10 Geotechnical Design

Software shall be as proposed by the DB Contractor, subject to approval of the Mobility Authority and any appropriate regulatory agencies. The software packages pre-approved by the Mobility Authority are:

- CAPWAP
- DRIVEN
- gINT
- GRLWEAP
- LPILE and LPILEPLUS
- MSEW
- SHAFT
- SLIDE

- SLOPE-W
- WINCORE
- SETTLE3D
- SNAILZ
- SNAP
- AASHTOWare

1.4.11 Pavement Design

Software shall be as proposed by the DB Contractor, subject to approval of the Mobility Authority and any appropriate regulatory agencies. The software packages pre-approved by the Mobility Authority are:

- TxCRCP-ME
- DARWin (pavement design software)
- DARWin-MET SLAB
- FPS21

1.4.12 Structural Design

Software shall be as proposed by the DB Contractor, subject to approval of the Mobility Authority and any appropriate regulatory agencies. The software packages pre-approved by the Mobility Authority are:

- BGS
- BMCOL51
- CAP 18
- CONSPAN
- GT STRUDL
- LARSA 4D
- LUSAS
- MATHCAD
- MDX
- SPCOLUMN
- PSTRS14
- RCPIER

- PGSUPER
- RISA 3D
- SAP2000
- STAAD
- STLBRIDGE

1.4.13 Sign Design

Software shall be as proposed by the DB Contractor, subject to approval of the Mobility Authority and any appropriate regulatory agencies. The software package pre-approved by the Mobility Authority is SignCAD.

1.4.14 Traffic Modeling and Signal Design

Software shall be as proposed by the DB Contractor, subject to approval of the Mobility Authority and any appropriate regulatory agencies. The software packages pre-approved by the Mobility Authority are:

- Highway Capacity Software (by McTrans)
- Synchro/SimTraffic
- VISSIM

1.4.15 Advanced Traffic Management System (ATMS) Design

Software shall be as proposed by the DB Contractor, subject to approval of the Mobility Authority and any appropriate regulatory agencies. The software packages pre-approved by the Mobility Authority are:

- ArcView (by ESRI)
- ArcINFO
- FREQ
- Integration
- MINUTP (by Comsis)

1.4.16 Architectural Plans

Software shall be as proposed by the DB Contractor, subject to approval of the Mobility Authority and any appropriate regulatory agencies.

1.4.17 Project Scheduling

The scheduling software employed by the DB Contractor shall be compatible with the current and any future scheduling software employed by the Mobility Authority (currently Primavera 8.3). Compatible shall mean that the DB Contractor-provided electronic file version of a schedule may be loaded or imported by the Mobility Authority using the Mobility Authority's scheduling software with no modifications, preparation, or adjustments to do so.

1.4.18 PC Operating System, Word Processing, and Spreadsheets

The operating system must be compatible with the current Mobility Authority standard, Windows 10. Only those operating systems meeting current Mobility Authority standards will be acceptable; all computer equipment furnished with operating systems not meeting current Mobility Authority standards will be rejected.

The DB Contractor shall use the following software: Microsoft Office 2016 (Professional Edition)

1.4.19 Construction Quality Control Inspection and Material Testing

Software for construction quality control inspection and material testing shall be compatible with the Mobility Authority's needs and be approved by the Mobility Authority. The DB Contractor shall submit a commercially available software specification to the Mobility Authority for review and approval within 5 Business Days after NTP 1. The final software to be used for construction activity tracking will be determined by the Mobility Authority within 20 Business Days after receipt of the DB Contractor's submittal.

1.5 Electronic Communications Requirements

1.5.1 Communications Management

All Project data shall be shared between the DB Contractor and the Mobility Authority. Implementation details will be arranged after issuance of NTP 1. At a minimum, data sharing shall accommodate the following Mobility Authority requirements.

1.5.2 Electronic Files

All hard copy submittals for review (including plans, specifications, and data) shall be accompanied with electronic representations of the pages using Adobe Acrobat PDF files. These files shall be searchable and not compressed. At the request of the Mobility Authority, the DB Contractor may be required to supply the submittal data in the software format in which the submittal was created.

1.5.3 Mobility Authority Audit

Audits. The Mobility Authority shall have access to the design data files only for auditing purposes. (No ‘change permissions’).

1.5.4 Network Communications

The DB Contractor must provide to all Project offices Internet access and be able to communicate using secure file transfer protocol (FTP), secure e-mail, and secure websites.

1.5.5 File Transfer Protocol

The DB Contractor shall make all submittals available to the Mobility Authority via the DB Contractor’s electronic document control system described in *Technical Provision 1.3.5*. The DB Contractor shall provide the Mobility Authority with procedures and software, if necessary, for accessing the submittals, including user identification, secure passwords, and website address.

The website shall be segregated into Adobe Acrobat PDF files and actual design data files. All Adobe Acrobat PDF and data files shall be well organized and easy to locate.

The DB Contractor shall maintain the website and keep it up-to-date with the latest plan, design, and construction file data.

File transfer shall be conducted as follows:

- The DB Contractor shall not include any files as attachments to electronic mail (e-mail) messages.
- E-mail may be used to notify the Mobility Authority of the availability of document files on the File Transfer Website, and must include a link to the document file to facilitate ease of use.

1.5.6 E-mail Guidelines

The DB Contractor shall use an e-mail system which meets the following limitations:

Format. All e-mail messages must be in rich text or HTML.

Sensitive Information. All information which is considered sensitive materials or confidential information shall not be sent via e-mail.

1.6 Submittals

Table 1-1: Submittals to Mobility Authority

Submittals	Submittal Schedule	Mobility Authority Action	Reference Section
Project Management Plan (PMP)	Within 30 days of issuance of NTP 1.	Acceptance	1.1.2
Key Personnel Change	20 Business Days in advance of a proposed replacement of any Key Personnel	Review and Approval	1.1.3.3
Key Personnel Directory	30 Business Days after issuance of NTP 1	Information	1.1.3.3
Project Organization Chart	As part of the Project Management Plan (PMP)	Information	1.1.3.3
Weekly Meeting Draft Minutes	Within 2 Business Days	Review and Comments	1.1.4.1
Weekly Meeting Final Minutes	Within 1 Business Days	Information	1.1.4.1
Proposed Subcontracting Plan	1. Within 20 Business Days after issuance of NTP 1, 2. Update Monthly	Review	1.1.5
Construction Quality Control Inspection and Material Testing Software	5 Business Days after NTP 1	Review and Approval	1.4.19

2.0 QUALITY MANAGEMENT

2.1 Quality Management Program

2.1.1 Responsibilities

DB Contractor Responsibility. The DB Contractor shall be responsible for the design and construction quality of the Project and for fully complying with its accepted quality management program. The goal of the program is to maximize Project quality by requiring the daily attention and continued efforts of every worker who is involved with the design and construction of the Project, from issuance of Notice To Proceed (NTP 1) to Final Warranty Acceptance (FWA). The DB Contractor shall develop the program in accordance with the requirements in this *Technical Provision 2* and in 43 TEX. ADMIN. CODE § 27.56.

Mobility Authority Role. The Mobility Authority will supplement the DB Contractor's quality management program with implementation of the Construction Quality Assurance Program (QAP).

2.1.2 Program Goals

Integrated Program. The DB Contractor shall develop and implement a quality management program that:

- Establishes comprehensive quality management procedures.
- Integrates the quality goals of both the design and construction elements of the Project.
- Defines the minimum standards and procedures for quality management.
- Assigns the responsibilities for specific quality management functions.

Flexibility. The description of the quality management program in this *Technical Provision 2* is not intended to be all encompassing, but to give the DB Contractor and the Mobility Authority the flexibility to design a program that best fits the needs of the Project and both parties.

2.1.3 Quality Management Plans

Although the overall concepts and goals of the quality management program apply to the Project as a whole, the DB Contractor shall describe and specify its program by developing and implementing a Quality Management Plan (QMP), as specified herein:

- Design Quality Management Plan (DQMP) (*Technical Provision 2.3.1*)
- Construction Quality Management Plan (CQMP) (*Technical Provision 2.4.1*)

These plans shall be consistent with and expand upon the quality approaches and commitments described in the draft DQMP and draft CQMP submitted with the Proposal.

The QMP shall describe the system, policies, and procedures that ensure the Work meets the requirements of the Contract Documents. The QMP shall encompass all Work performed by the DB Contractor and Sub-contractors of all tiers. The QMP shall describe the authority and responsibility for the administration of the QMP and describe how all requirements of the Contract Documents will be met.

The QMP shall contain detailed procedures for the DB Contractor's QA/QC activities. The DB Contractor's quality process shall incorporate planned and systematic verifications and audits. The DB Contractor shall conduct all QA/QC in accordance with the QMP and the requirements of the Contract Documents.

The DB Contractor shall regularly maintain the QMP to contain current versions of the following information:

- The organizational chart that identifies all quality management personnel, their roles, authorities and line reporting relationships. Personnel relationships relating to quality shall comply with the requirements in these *Technical Provisions*.
- Names, contact details, titles, description of roles responsibilities, and specific experience of all quality management Key Personnel, other quality management personnel and those who have the authority to stop Work.
- Identification of testing agencies, including information on each agency's capability to provide the specific services required for the Work, certifications held, equipment used, and location of laboratories for products produced both on and off the Site.
- Identification of what products or services are to be subcontracted, updated when new Subcontractor or Supplier contracts are implemented.

The QMP procedures shall:

- Ensure the DB Contractor personnel, including Subcontractor personnel, are familiar with all the provisions of the Contract Documents concerning their respective responsibilities.
- Provide for the education, training and certification, as appropriate, of personnel performing activities affecting or assessing the quality of the Work to assure such personnel achieve and maintain the required proficiency.
- Ensure the Work is performed according to the QMP, Good Industry Practice, and the Contract Documents.

The DB Contractor shall plan the training required for each individual and maintain a register demonstrating the QMP training record of all personnel affecting quality.

The QMP shall be conformed and updated annually. The DB Contractor shall revise its QMP within 14 days of the Mobility Authority's or the DB Contractor's detection of a substantial or systemic problem

related to the Work, or as directed by the Mobility Authority. Submissions of the QMP and all updates to the QMP shall include both a clean copy and a copy tracking all changes since the previous approval.

Technical Provision 2.3.1 and 2.4.1 describe the minimum requirements to be addressed in the DB Contractor's DQMP and CQMP.

The DB Contractor shall submit the QMP for the Mobility Authority's review and acceptance within 30 days of issuance of NTP 1.

2.2 Definitions

Design Program Definitions

The DB Contractor shall use the following definitions in preparing the DQMP and executing the Design Work:

Design Quality Control (DQC): The actions of the DB Contractor in examining, verifying, checking and certifying design elements and calculations to determine the correctness and accuracy of the Project Design. The DB Contractor QC activities shall be performed under the direction of the Design Manager.

Design Quality Assurance (DQA): Shall mean quality assurance checks of the design quality control program performed by DB Contractor staff. The staff shall be independent of the production staff and under the direction of the Design Quality Assurance Manager (DQAM).

Design Acceptance: Shall mean the Mobility Authority's program to provide confidence that the DQMP objectives and results meet the requirements of the Contract Documents. While the DB Contractor retains responsibility for internal quality control and quality assurance of its design products, the Mobility Authority's Design Acceptance program will include external assurance reviews of the DB Contractor's processes that may include calculation checks, plan reviews, audits of the DB Contractor's DQMP or other actions as deemed appropriate by the Mobility Authority.

Design Quality Control and Quality Assurance Personnel: The DB Contractor's personnel with specific design quality control and quality assurance (QC/QA) responsibilities.

Early Release-for-Construction Plans: Partially completed plans that have sufficient detail for construction elements to be constructed early, at the risk of the DB Contractor. Early construction items are items that can and, if necessary, shall be changed (at no cost to the Mobility Authority) by the DB Contractor as the design proceeds; items may include, but are not limited to, clearing and grubbing, stripping topsoil, subgrade construction, and temporary traffic crossovers.

Released-for-Construction Plans: Plans that are completed sufficiently to provide proper guidance for the construction of an element or portion of the Work.

Construction Program Definitions

The DB Contractor shall use the following definitions in preparing the CQMP and executing the Construction Work:

Quality Assurance Program (QAP): The Mobility Authority's program of planned policies, procedures, detailed responsibilities, and systematic actions necessary to provide confidence that the construction quality management and results meet the requirements of the Contract Documents related to the final construction elements; includes discretionary construction oversight, and audits of the DB Contractor's construction quality control.

Construction Quality Control (CQC): The actions of the DB Contractor in examining, witnessing, inspecting, checking, testing and certifying in-process Work to determine conformity to Project construction requirements. The CQC shall be performed by a CQCM.

Material Acceptance: The actions of viewing or looking carefully at construction practices, products, and processes (including document control and shop drawings) to ensure compliance with the quality requirements contained in the Contract Documents. Material Acceptance shall be performed by the Mobility Authority.

Materials Acceptance Testing (MAT): Shall mean material tests and related activities performed by the Mobility Authority that form the basis of the material acceptance decision verifying that all materials incorporated into the Work are in conformance with the CQMP and the requirements of the Contract Documents pursuant to the *Mobility Authority's Quality Assurance Program for Design-Build Projects with Agency Acceptance Provisions*.

2.3 Design Quality Management

Documentation. The DB Contractor shall maintain a record of internal design quality activities. A summary of the design review activities and design quality proceedings shall be included with the monthly Project Schedule documents submittals in accordance with *Technical Provision 5.3*.

2.3.1 Design Quality Management Plan (DQMP)

The DB Contractor shall prepare and submit a Design Quality Management Plan (DQMP) based on the Draft DQMP submitted in its Proposal that addresses Design Quality Control (DQC) and Design Quality Assurance (DQA).

2.3.1.1 General

DB Contractor Responsibility. The objective of the DQMP is to place the responsibility for conducting DQC and DQA review duties solely with the DB Contractor and the Design Acceptance duties solely with the Mobility Authority. This arrangement allows the Mobility Authority to fulfill its responsibilities of

exercising due diligence in overseeing the design process and accepting the design products. The Mobility Authority reserves the right to audit the DQMP at any time during the Project.

Design Standards. The DQMP shall include procedures to ensure that all investigations, reports, calculations, plans, and specifications are prepared in accordance with accepted design and engineering practices as governed by the Contract Documents.

General Requirements. The DQMP shall outline:

- Systematic approach to the Project Design on a task level basis by defining the processes, procedures, design criteria, and documentation to be used.
- Comprehensive CAD standards and file naming structure.
- List of Design Packages.
- Design submittal work flow including planned Early Release for Construction design packages.
- Design submittal work flow including Released-for-Construction design packages.
- The DB Contractor's internal DQC procedures to be followed by design production personnel during Project Design.
- The DB Contractor's DQA procedures.

2.3.1.2 Mobility Authority Review

Final DQMP. The DB Contractor shall submit the final DQMP for review and comment by the Mobility Authority within 20 Business Days after NTP 1. The DB Contractor shall not begin design until after acceptance of the DQMP. If the DB Contractor begins design before resolving all comments to the satisfaction of the Mobility Authority, it shall do so only at its sole risk. The Mobility Authority reserves the right to withhold payment for the Work until the Mobility Authority accepts the DQMP. If the proposed DQMP is unacceptable to the Mobility Authority, the DB Contractor shall modify and resubmit an acceptable plan. Once the plan is accepted, the DB Contractor shall not revise any portion without the prior written acceptance of the Mobility Authority.

2.3.1.3 DQMP Contents

The DQMP shall describe and include at least the following:

Responsibilities. Clear definition of the specific responsibilities of the Design Firm's internal DQC/DQA functions and duties.

DQC Procedures. The DQC procedures are for the design plans; specifications; reports; calculations, and other construction documents, organized by engineering disciplines (such as structural, civil, and utilities). These procedures shall specify measures to ensure that appropriate quality requirements are specified and

included in Design Documents and to control deviations from such requirements. The DB Contractor shall not deviate from such procedures unless the deviations have been previously approved by the Mobility Authority in writing.

Independent Plan Checking. The DQC procedures for ensuring independent checking of the preparation, verification, and checking of all plans, specifications, calculations, reports, and other submitted items.

Procedures for Released-for- Construction Plans. Specific DQC procedures for items planned for early construction, including specific procedures for verifying the final design and any computer programs used for design.

Identification of Design Personnel. Clear identification of the designer and checker on the face of all final design documents. Plans, specifications, calculations, reports, and other documents shall be certified, signed, and dated by the engineer in responsible charge for that item or element of the Project.

Adequacy of Design. Description of the level, frequency, and methods of checking the adequacy of the Project design for all Design Documents.

Coordination. Procedures for coordinating the various design activities that are performed by different individuals or firms for related tasks. The coordination procedures shall include the review, approval, release, distribution, and revision of documents involving such parties. These procedures shall ensure that conflicts, omissions, or misalignments do not occur between drawings or between the drawings and the specifications.

Personnel Qualifications. Procedures to:

- Ensure that the DB Contractor’s personnel are familiar with all the provisions of the Contract Documents concerning their respective responsibilities.
- Provide for the education, training, and certification (as appropriate) of personnel performing activities affecting or assessing the quality of the Project Design to ensure that such personnel achieve and maintain reasonable proficiency.

Standards. Procedures to ensure that the Project Design is performed according to the DQMP, generally accepted engineering practices in the State of Texas, and the Contract Documents.

Documentation. The specific responsibilities of personnel responsible for satisfying documentation requirements and procedures for meeting documentation requirements; for filing design criteria, reports, notes, calculations, plans, specifications, schematic drawings, and supporting materials needed during the Final Design; and for developing Record Drawings. The DB Contractor shall maintain, organize, and index all Design Documents and make copies available to the Mobility Authority upon request.

Audits. Procedures and schedules for the DQAM to audit the Design Firm’s QC & QA procedures and to interface with the Mobility Authority.

Formal Design Reviews: Plan reviews shall be set up by the Design Manager at the following stages of design:

- Preliminary (30%) Design Submittal
- Intermediate (65%) Design Submittal
- Final (100%) Design Submittal

2.3.2 Design Quality Control/Assurance Personnel

2.3.2.1 Quality Control/Assurance Personnel

The following Design Quality Control Personnel positions shall be identified in the DQMP.

Design Manager. The DQC responsibilities of the Design Manager (DM) include assigning staff to perform QC reviews of the design plan submittals and ensuring that the QC is performed in accordance with the accepted DQMP prior to commencement of the DQA activities as described below in Technical Provision 2.3.4.

Design Quality Assurance Manager. The DB Contractor shall designate a Design Quality Assurance Manager (DQAM) who shall:

- Be a Registered Professional Engineer.
- Be responsible for management of the DQMP.
- Have no involvement with direct scheduling or production activities.
- Conduct monthly reviews with the Mobility Authority to review progress and any areas of concern identified during the design QC/QA reviews and the Mobility Authority Design Acceptance reviews.

Design QC/QA Engineers. The design QC/QA staff shall include experienced engineers to perform detailed checks of all design calculations and review of construction plans as defined by the DB Contractor’s quality control plan. An engineer shall be considered qualified to perform design QC/QA if he/she is an engineer and has practiced in the design discipline and type of Work being checked for at least 5 years.

2.3.3 Design Quality Control

DQC as outlined in the DQMP shall include:

- The preparation of all design elements under the direct supervision of a Registered Professional Engineer.
- The complete check of all calculations and drawings by experienced engineers as defined in *Technical Provision 2.3.2*.
- Establishment of a systematic approach to the Project Design by defining the processes, procedures, and documentation to be used.
- Interdisciplinary design checks to ensure compatibility with other design disciplines.
- A constructability review.
- The complete check of all requirements of the Contract Documents.

2.3.4 Design Quality Assurance

The design quality assurance (DQA) reviews will be performed by the DB Contractor and shall include:

- Checks and fatal flaw reviews to assure compliance with the requirements of the Contract Documents.
- Audit of records, documentation, procedures, and processes to verify compliance with the accepted DQMP.
- Audits of design to verify compliance with these *Technical Provisions*.

Revisions. After each review, the DB Contractor shall address all comments and concerns by revising the design and plans to the DQAM & the Mobility Authority’s satisfaction.

Periodic DQA Checks. The DQA check shall include a general review of all plans, reports, calculations, specifications, and supporting materials incorporated into the Design Documents.

Design Certification. The DQAM shall certify, prior to any design submittal to the Mobility Authority, that the submittal has been through the DQC and DQA processes and meets the DQMP standards and the requirements of the Contract Documents.

2.3.5 Design Acceptance

The Mobility Authority will perform the Design Acceptance reviews and reserves the right to audit the DB Contractor’s DQMP operations. The DB Contractor shall request and obtain Mobility Authority acceptance on a design package prior to the package being released for construction. Such acceptance shall not relieve the DB Contractor of its sole responsibility and liability for designing the Project in accordance with all applicable Laws, Governmental Approvals, TxDOT Standards and Specifications, AASHTO’s Guidelines, and the Contract Documents, nor shall it affect the legal and professional obligations applicable to the DB Contractor’s engineers in charge to provide a sound engineering design for the Project.

2.3.5.1 Over-the-Shoulder Reviews

Purpose and Description. Over-the-shoulder reviews are informal examinations by the Mobility Authority of Design Documents during the Project Design process and are not intended to be an acceptance of any portion of the design. Over-the-shoulder reviews will mainly assess whether the requirements and design criteria of the Contract Documents are being followed and whether the DB Contractor's DQC and DQA activities are being undertaken in accordance with the accepted DQMP. The over-the-shoulder reviews may include any relevant design information as requested by the Mobility Authority.

Extent. It is the intent of these over-the-shoulder reviews to check for concept, level of detail, design criteria, and fatal flaws. These reviews will not routinely include detailed calculation or drawing reviews, although the Mobility Authority retains the right to perform detailed reviews of any item at any time. If mutually agreed upon between the parties, for specific review items, the over-the-shoulder review may consist of an exchange of electronic files between the DB Contractor's Design Firm and the Mobility Authority.

2.3.5.2 In-Progress Design Workshops

In addition to the mandatory in-progress design workshops required below, throughout the design process, the DB Contractor or the Mobility Authority may request (at least 5 Business Days in advance) additional in-progress design workshops to discuss and verify design progress and to assist DB Contractor and its Design Firm(s) in resolving design questions and issues. The workshop is informal and discussions are non-binding unless agreed to by both parties in writing.

Timing. The following mandatory in-progress design workshops shall be conducted in the DB Contractor's office no later than 2 weeks prior to each of the following submittals:

- Preliminary (30%) Design Submittal
- Intermediate (65%) Design Submittal
- Final (100%) Design Submittal
- Released-for-Construction (RFC) Submittals

3-D Design Model. The DB Contractor shall present a Project 3-D design model to the Mobility Authority and stakeholders at the in-progress design workshops in accordance with Technical Provision 1.4.7.

Preparation. At least 5 Business Days prior to each in-progress workshop, the DB Contractor shall assemble and submit drawings or other documents to be reviewed during the workshop to the Mobility Authority for its information and review. With respect to the 3-D design model that will be reviewed at the workshops, the DB Contractor shall submit the following at least 5 Business Days prior to each workshop:

- Adobe PDF file of Project 3-D model which shall include proposed striping; and

- All CADD and other electronic files used to develop the 3-D model along with all associated files required to duplicate the model; and
- Updated Utility Adjustment Concept Plan.

Review Records. Within 5 Business Days after the in-progress workshop the DB Contractor shall submit a written record of the in-progress design workshop, including:

- A list of the participants in attendance.
- Description of the items covered and discussed .
- Identification of discrepancies and comments, and a report on corrective actions (both those taken and those planned).
- Identification of follow-up action items, due dates, the party responsible for action items requiring resolution, and deadlines for resolution.

2.3.5.3 Mobility Authority Visits

Throughout the design process, the Mobility Authority may make visits to discuss and verify design progress and ascertain the overall progress of the Project with respect to the DB Contractor’s DQMP. If, at the sole option of the Mobility Authority, the DB Contractor is not meeting the goals and objectives of the DQMP, the DB Contractor shall suspend all Project Work and the Mobility Authority may withhold payment in accordance with DBA Section 13.3.12.

2.3.6 Submittal and Review Process

Working Meetings. The DB Contractor shall conduct a series of working meetings with staff, the DQAM, and the Mobility Authority to establish and mutually agree upon procedures to be utilized during the design review process that are consistent with the Contract Documents. These procedures shall be included in the DQMP. The working meetings are also to develop an understanding on general design concepts, such as the geometric design, aesthetics, drainage, maintenance of traffic, pavement design, and structures.

Review by Design Package. At a minimum, the DB Contractor’s design QC/QA engineers shall conduct detailed reviews of mandatory design submittals for each Design Package, as indicated in the DQMP. The Mobility Authority shall be notified and may attend the submittal reviews, and the DB Contractor shall maintain formal documentation of these meetings for the Mobility Authority’s audits. The Mobility Authority may choose to audit these reviews at any time.

Purpose. The purpose of the submittal reviews is for the design QC/QA engineers to verify and document that all design is proceeding in accordance with Project requirements, good engineering practice, applicable Law, the Governmental Approvals, and the Contract Documents.

DQAM Role. Prior to submittal to the Mobility Authority for review, all design calculations and drawing submittals shall undergo internal checks for accuracy, constructability, and thoroughness by the DQAM and QA staff. The DQAM shall not submit packages to the Mobility Authority until all internal checks are completed as outlined in the DQMP.

Mobility Authority Role. All submittals are subject to review and acceptance by the Mobility Authority. Resubmittal of any Design Document for review may be required as appropriate to obtain acceptance from the Mobility Authority. The Mobility Authority shall refuse and reject any submittal that does not comply with the requirements of applicable Law, the Governmental Approvals, or the Contract Documents.

TxDOT and FHWA Role. The Mobility Authority has entered into a project development agreement (PDA) that requires TxDOT to concurrently review and concur with the design submittals with FHWA oversight. The DB Contractor shall provide the Mobility Authority with electronic copies of each design submittal via the DB Contractor’s electronic document control system as required in *Technical Provision 1.3.5* for the Mobility Authority to submit to TxDOT and FHWA for review. All FHWA submittals will be provided through TxDOT.

Design Submittals. The DB Contractor may split the Project into multiple segments as approved by the Mobility Authority for which separate Preliminary (30%) Design, Intermediate (65%) Design, and a Final (100%) Design Submittal packages may be submitted. The location where the segments adjoin shall be clearly identified and submitted to the Mobility Authority for acceptance prior to submitting the Preliminary Design.

Mandatory Design Submittals. The DB Contractor’s Design Firm shall furnish to the Mobility Authority at least three mandatory design submittals (as described herein) and any necessary resubmittals. The mandatory submittals are:

- Preliminary (30%) Design Submittal
- Intermediate (65%) Design Submittal
- Final (100%) Design Submittal

Review Time Requirements. The Mobility Authority, TxDOT and FHWA will complete their concurrent reviews of the DB Contractor’s plans and submittals based on the following review time requirements. Durations shown are inclusive of Mobility Authority, TxDOT and FHWA review times. Business Days for these review times shall exclude state and federal holidays.

Determination if Submittal is complete & acceptable (prior to each Submittal review)	5 Business Days
Preliminary (30%) Design Submittal:	15 Business Days
Intermediate (65%) Design Submittal:	20 Business Days
Final (100%) Design Submittal:	15 Business Days

Release For Construction (RFC) Submittal:	15 Business Days
Early Release for Construction (ERFC) Submittal:	15 Business Days
RFI Submittal:	5 Business Days

Note: Review times are based on receipt of no more than 2 plan submittals per day up to 3 continuous Business Days within the same discipline and no more than 6 plan submittals of any combination of disciplines per day up to 3 continuous Business Days.

The DB Contractor shall provide an advance notice to the Mobility Authority a minimum of 10 Business Days prior to submitting a Preliminary (30%), Intermediate (65%), or Final (100%) Design Submittal package. If the package is not received on the date indicated in the advance notice, the Mobility Authority shall retain the right to revise the review deadlines by 1 Business Day for every Business Day the package was submitted earlier or later than the date indicated in the advance notice.

2.3.7 Design Submittals

2.3.7.1 Preliminary (30%) Design Submittals

Purpose. The purpose of the Preliminary (30%) Design Submittal is to obtain acceptance by the Mobility Authority of the DB Contractor’s roadway typical sections, horizontal and vertical geometric design, bridge clearances, and limits of the Project.

Content. The 30% Submittal shall include all plans, specification and other documents required for the submittal per Technical Provision 2.3.8. The submittal shall also include all accepted modifications to the Basic Configuration and design standards, all property requirements, impacts on Federal and State jurisdictional wetlands, subsurface geotechnical investigations and recommendations, slope stability analysis and recommendations, settlement monitoring program, vibration monitoring program, and construction specifications. Along with or prior to the Preliminary (30%) Design Submittal, the DB Contractor shall document and justify all Design Exceptions consistent with the procedures outlined by the Mobility Authority.

DQAM Role. Prior to submitting to the Mobility Authority, the DQAM shall certify that the Preliminary Design Submittal package has been checked in accordance with the DB Contractor’s accepted DQMP and the Contract Documents.

Mobility Authority Role. The Mobility Authority shall notify the DB Contractor within 5 days if the submittal is complete and acceptable for review per Technical Provision 2.3.8. If acceptable, the Mobility Authority will submit to TxDOT for its review and complete the Mobility Authority review. If rejected, the DB Contractor will be required to resubmit. If rejected, a meeting will be conducted between the Mobility Authority and the DQAM to discuss the deficiencies in the submittal.

2.3.7.2 Intermediate (65%) Design Submittals

Purpose. The purpose of the Intermediate (65%) Design Submittal is to ensure that the design is progressing in accordance with the requirements of the Contract Documents, applicable Law, and the Governmental Approvals. The Intermediate (65%) Design Submittal shall also ensure that:

- Existing field conditions have been properly identified and addressed.
- The various design disciplines and elements of the Project are being properly coordinated between the DB Contractor and persons responsible for adjacent Work, appropriate landowners, Utility Owners, developers, contractors, Railroads, and Governmental Entities.

Content. The Intermediate (65%) Design Submittal shall include all plans, specification and other documents required for the submittal per Technical Provision 2.3.8. The submittal shall also include preliminary construction plans not yet submitted as appropriate to demonstrate sufficient interdisciplinary design coordination., resolution to all comments made on the Preliminary (30%) Design Submittal, specifications, and design information indicating the DB Contractor's interpretations of the design requirements of the Contract Documents.

DQAM Role. Prior to submitting to the Mobility Authority, the DQAM shall certify that the Intermediate Design Submittal package has been checked in accordance with the DB Contractor's accepted DQMP and the Contract Documents.

Mobility Authority Role. Notify within 5 days if submittal is complete and acceptable for review per Technical Provision 2.3.8. If acceptable, the Mobility Authority will submit to TxDOT for their review and complete the Mobility Authority review. If rejected, the DB Contractor will be required to resubmit. If rejected, a meeting will be conducted between the Mobility Authority and the DQAM to discuss the deficiencies in the submittal.

2.3.7.3 Final (100%) Design Submittal

The DB Contractor shall submit the Final (100%) Design Submittal package with DQAM certification. The Mobility Authority shall perform a formal review of the DQAM certified package and provide comments. Upon addressing all review comments to the Mobility Authority's satisfaction and meeting the requirements of this Technical Provision 2.3.7.3, the DB Contractor may prepare the Released-for-Construction (RFC) package for Design Acceptance by the Mobility Authority.

Organization. Construction packages for individual Work elements shall be organized such that the Final (100%) Design Submittal package can be assembled into a Released-for-Construction package that could be used to construct the Work or could be used with minor revisions for Record Drawings.

DQAM Role. When the DB Contractor has completed the Final (100%) Design Submittal package, the DQAM shall certify that:

- The design meets all applicable requirements of the Contract Documents, applicable Law, and the Governmental Approvals.
- The design has been checked in accordance with the DB Contractor’s accepted DQMP and the Contract Documents.
- The item or element is ready for construction.
- All required ROW has been secured, along with any and all approvals from governmental agencies, Utility Owners, and Railroads.
- All comments from previous reviews have been incorporated into the Final (100%) Design Submittal package.

After the DQAM certifies the above items, the Mobility Authority will conduct a formal review of the Final (100%) Design Submittal package for said item or element.

Contents. The Final (100%) Design Submittal package shall include all plans, specification and other documents required for the submittal per *Technical Provision 2.3.8*. The submittal shall consist of complete Design Documents, incorporating resolution of all review comments and any over-the-shoulder comments. All documentation, including the comments of the DQC and DQA reviews, DQAM written certifications, copies of the Mobility Authority’s approval of deviations from design standards, and/or approved Design Exceptions shall be provided.

Mobility Authority Role. The Mobility Authority shall notify the DB Contractor within 5 days if the submittal is complete and acceptable for review per *Technical Provision 2.3.8*. If acceptable, the Mobility Authority will submit to TxDOT for their review and complete the Mobility Authority review. If rejected, the DB Contractor will be required to resubmit. If rejected, a meeting will be conducted between the Mobility Authority and the DQAM to discuss the deficiencies in the submittal.

Process. The DB Contractor shall incorporate comments from the Mobility Authority into the Final (100%) Design Submittal package and resubmittals and resolve all concerns and questions to the satisfaction of the Mobility Authority and TxDOT. Then the DB Contractor shall resubmit to the Mobility Authority the Final (100%) Design Submittal package, which shall include (at a minimum):

- Design plans.
- Design calculations.
- Design reports.
- Specifications.
- Electronic files.
- Governmental, Utility Owner, and Railroad approvals.
- DQAM Certification of Compliance with the DQMP and Contract Documents.

Deficiencies. If the Mobility Authority determines that the Final (100%) Design Submittal package does not meet the requirements of the Contract Documents, applicable Law, and the Governmental Approvals, the Mobility Authority will notify the DB Contractor in writing of any specific deficiencies in the package. Upon receipt of the Mobility Authority's comments, the DB Contractor shall correct such deficiencies and modify the Final (100%) Design submittal package for resubmittal.

2.3.8 Plan Submittal Requirements

2.3.8.1 Plans and Specifications

The DB Contractor shall produce plans and specifications that aid and facilitate design review by the Mobility Authority, TxDOT, and FHWA and provide adequate information for safe, efficient, and high-quality construction. Plan sets and sheet types shall be developed in accordance with the Design Quality Management Plan, the TxDOT PS&E Preparation Manual and local City and County requirements for facilities they have jurisdiction over, before construction may begin. The submittals shall include (at a minimum) the following plan sheet types for each Design Submittal as indicated below in **Table 2-1**.

Table 2-1: Plan Sheet Types by Design Submittal

SHEET TYPE		DESIGN SUBMITTAL		
		30%	65%	100%
I.	General			
	Title Sheet	X	X	X
	Project Layout/Index	X	X	X
	Typical Sections	X	X	X
	General Notes (Austin District Master General Notes shall be provided to the DB Contractor for development of General Notes. All applicable special specifications and special provisions as of the date of the Proposal shall be included)		X	X
II.	Traffic Control Plan			
	Typical Sections	X	X	X
	Phases Narrative		X	X
	Phase Layouts		X	X
	Detour Layout and Barricade Layout		X	X
	Temporary Traffic Signals, Illumination		X	X
	TxDOT Standard Plans		X	X
III.	Roadway Details			
	Removal Plans		X	X
	Alignment Data Sheets		X	X
	Survey Data and Control Plans	X	X	X
	Plan and Profile	X	X	X
	Intersection Details		X	X

SHEET TYPE		DESIGN SUBMITTAL		
		30%	65%	100%
	Driveway Details		X	X
	Miscellaneous Details		X	X
	TxDOT Standard Plans		X	X
IV.	Retaining Wall Details			
	Wall Layouts (sheets laid out so profile view is of wall face)	X	X	X
	Retaining Wall Design Details		X	X
	TxDOT Standard Plans		X	X
V.	Drainage Details			
	Hydraulic/Hydrologic Data	X	X	X
	Drainage Area Maps	X	X	X
	Drainage Discharge Calculation Table		X	X
	Inlet Capacity/Ponding Calculation Table		X	X
	Pipe/Culvert Flowline and Length Table		X	X
	Pipe/Culvert Hydraulic Calculation Table		X	X
	(Including Hydraulic Grade Line Elevation, Flow Velocity)		X	X
	Water quality BMP design and calculations	X	X	X
	Culvert Layouts – All Types – Bridge Classification	X	X	X
	Pavement Underdrain Plans		X	X
	TxDOT Standard Plans		X	X
VII.	Utilities			
	Existing Utilities (Plan and Profile) Layout	X	X	
	Proposed Utilities (Plan and Profile) Layout		X	X
	Standards (for each utility type)		X	X
VIII.	Bridge			
	Bridge Hydraulic Data Sheets		X	X
	Bridge Layouts	X	X	X
	Foundation Layouts and Details		X	X
	Boring Logs	X	X	X
	Bridge Details		X	X
	TxDOT Standard Plans		X	X
IX.	Traffic Items			
	Traffic Signal Layouts		X	X
	Illumination		X	X
	Signing		X	X
	Pavement Markings		X	X
	Intelligent Transportation System (ITS)		X	X
	TxDOT Standard Plans		X	X
X.	Environmental Issues			

SHEET TYPE		DESIGN SUBMITTAL		
		30%	65%	100%
	SW3Ps		X	X
	Sensitive Areas	X	X	X
	Wetland Mitigating Plan		X	X
	TxDOT Standard Plans		X	X
XI.	Miscellaneous Items			
	Aesthetic Plans and Details	X	X	X
	Landscaping/Irrigation		X	X
	Preserved Trees		X	X
	Designated Preservation Areas		X	X
	Mandatory Sustainability Plans and Details		X	X
	Roadway Cross Sections	X	X	X
	CRCP Joint Plan	X	X	X
XII	Toll Facilities			
	Toll Features Support Plan		X	X

2.3.9 Resubmittal Process

General. Resubmittals of any design package may be required if the Mobility Authority determines that the package is either incomplete or does not meet the requirements for submittal. Comments must be addressed and a package resubmitted within 20 Business Days of receipt of comments or all comments provided by the Mobility Authority will be deemed acceptable to and fully incorporated by the DB Contractor. Each resubmittal must address all comments received from a prior submittal in a manner satisfactory to the Mobility Authority. The resubmittal shall be considered at the same level of completion (i.e., 30%) as the previously submitted document. The DB Contractor shall not be entitled to any additional compensation or time extension due to any resubmittal requirement by the Mobility Authority review and Design Acceptance process.

The DB Contractor acknowledges and agrees that resubmittal of the Final (100%) Design Submittal package may be required. The DB Contractor shall resubmit the Final (100%) Design Submittal (as well as any other required design resubmittal) as many times as necessary to address the comments from the DQAM on the DQMP process and from the Mobility Authority.

Continuing Activities. The DB Contractor may continue its design activities, at its sole risk, during the resubmittal process. Such continuation in no way relieves the DB Contractor of the responsibility to incorporate the comments of the DQMP resubmittal process and the Mobility Authority into the Design Documents.

2.3.10 Released-for-Construction Submittals

A Released-for-Construction (RFC) plan submittal shall provide adequate information for safe, efficient, and high-quality construction. RFC Plans are intended to allow construction to begin on portions or elements of the Work after the Final (100%) Design Submittal has been certified by the DQAM and all concerns and questions have been addressed to the satisfaction of the Mobility Authority and TxDOT. At a minimum, the following activities shall occur prior to the Mobility Authority's Design Acceptance of a RFC Plan submittal:

- The Mobility Authority and TxDOT have concurred with the DQAM certification of the Final (100%) Design Submittal.
- The DQAM has certified that all comments have been addressed and incorporated into the RFC Plan submittal.
- All ROW required for the construction of the RFC Plan submittal has been acquired, or a right of use and possession agreement has been executed that allows for the construction of the portion of the Work.
- The DB Contractor has obtained the required approvals from applicable Governmental Entities and Railroads.
- The DB Contractor has coordinated the Work with the applicable Utility Owners.
- The DB Contractor has created a quantity estimate for the RFC Plan submittal.

DB Contractor Responsibility. The Mobility Authority's Design Acceptance will not constitute approval of the design or subsequent construction, nor relieve the DB Contractor of its responsibility to meet the requirements hereof irrespective of whether the Mobility Authority provides the DB Contractor with the authority to begin construction on elements of the Project prior to completion of the entire design. The DB Contractor shall bear the responsibility to ensure that construction meets the requirements of the Contract Documents, applicable Law, and the Governmental Approvals.

DB Contractor's Risk. The DB Contractor may proceed with construction of certain elements or portions of the Project in accordance with this Technical Provision before the design of the entire Project has been completed but only if accepted as RFC by the Mobility Authority.

Mobility Authority Review. Within the timescale specified in Technical Provision 2.3.6, Mobility Authority will notify the DB Contractor of its acceptance or rejection of its RFC plan submittal. The Mobility Authority will review RFC Plan submittals only for internal consistency as design packages. Impacts from future submittals cannot be anticipated by the Mobility Authority. The DB Contractor shall be obligated to revise Plans and construction as required to address changes as a result of design development.

Quantity Estimates. The DB Contractor shall provide quantity estimates for Project Work covered by RFC Plans. The quantity estimates shall be in units consistent with the requirements for quality acceptance sampling and testing.

2.3.11 Design Changes

Either the DB Contractor or the Mobility Authority may initiate design changes for items, elements, or phases undergoing construction or after Final Design.

RFI. In every instance in which the DB Contractor intends to or has constructed Work that deviates from the RFC Plans, the DB Contractor shall submit to the Engineer of Record (EOR) a Request for Information (RFI) and include, at a minimum, the plan set and sheet number containing the potential design change, a brief description of the change, and the reason why the item of concern cannot be or was not constructed in accordance with the RFC Plans.

The DB Contractor cannot resolve Nonconforming Work solely through the use of an RFI but shall follow the procedures defined in the CQMP, pursuant to the Mobility Authority's QAP and Section 7.4 of the DBA.

The Mobility Authority reserves the right to review all RFIs.

The DB Contractor shall use RFIs that identify minor changes to the Work to transfer that information to the Record Drawings. Minor changes are defined as those changes that do not require either a design change or modified calculations.

The DB Contractor shall submit a copy of RFIs that identify the need for either a design change or modified calculations as determined by the EOR, and do not require a Change Order, to the Mobility Authority for concurrence. If the Mobility Authority concurs with the request, then the DB Contractor shall submit a Notice of Design Change (NDC) to the EOR with a copy to the Mobility Authority to commence the design change process.

Quality Procedures. Any design change shall undergo the same design DQC and DQA procedures specified above for the original design, and must be documented and approved by the Design Firm responsible for the original design. All plans, final submittals, specifications, calculations, and reports for design changes shall be signed, sealed, and dated by a Registered Professional Engineer.

DQAM Role. For each design change to be accepted by the Mobility Authority, the DQAM shall certify in writing that the design change has been:

- Designed in accordance with the requirements of the Contract Documents, applicable Law, and the Governmental Approvals.
- Checked in accordance with the DB Contractor's accepted DQMP.

- Prepared consistently with other elements of the original design.

NDC Design Reviews. The DB Contractor shall schedule formal NDC reviews of design changes to the RFC Plans and Final Design Plans as agreed to by the Mobility Authority. The DB Contractor shall define both a single design review process and an interim and a final design review process for design changes dependent on the extent of the change. The process shall be subject to approval by the Mobility Authority and shall be defined in the DQMP.

Record Drawings. The DB Contractor shall also document all changes made through the NDC process in the Record Drawings.

2.3.12 Early Release for Construction (ERFC)

An ERFC Design Package may be submitted (after completion and Mobility Authority acceptance of the 30% design package and all other appropriate permits and approvals are obtained) by the DB Contractor to initiate an Early Start of Construction before obtaining the Mobility Authority's concurrence with the DQAM's certification of the Final 100% Design Submittal for the Final Design Package that includes said portions or items of the Work. The requirements of this *Technical Provision 2* shall apply to any portion of the Work that the DB Contractor performs before receiving the Mobility Authority's written acceptance of the Final (100%) Design Submittal for the respective portions or items of the Work. An ERFC Design Package must be approved by the DB Contractor's Design Manager and certified by the DQAM and accepted by the Mobility Authority prior to commencing construction. The Mobility Authority, at its sole discretion, may defer or reject ERFC for any portion or item requested by the DB Contractor.

Work that is constructed through the ERFC process is a portion or certain items of the Project that, under certain circumstances, can and, if necessary, shall be changed (at no cost to the Mobility Authority) by the DB Contractor as the design proceeds. Such items may include:

- Grading and Drainage Package
- Early Phase Traffic Control Package
- Bridge Substructure Package

The list above is provided as a reference of the types of design packages that could potentially be processed as ERFC; the Mobility Authority at its sole discretion will determine what is considered eligible for ERFC vs. RFC.

The procedures for ERFC shall be included in the DQMP, which procedures shall, among other things, include a process for distributing Construction Documents stamped "Early Release for Construction" signed and sealed by a Registered Professional Engineer to the Mobility Authority and the field staff of the DB Contractor. The DQMP shall also include a list of all design submittal packages for which the DB Contractor plans to use ERFC. The following design activities will be considered the minimum requirements to process an ERFC Design Package:

- The Mobility Authority has concurred with the DQAM certification of the Preliminary (30%) Design Submittals.
- All comments from previous reviews have been incorporated into the ERFC Design Package.
- All ROW required for the construction of the portion of the Work represented by the ERFC Design Package has been acquired, or a right of use and possession agreement has been executed that allows for the construction of the portion of the Work.
- The DB Contractor has obtained approval from applicable Governmental Entities and Railroads.
- The DB Contractor has coordinated the ERFC Design Package with the applicable Utility Owners.
- The DB Contractor has created a quantity estimate for the ERFC Design Package.
- The DB Contractor has received Mobility Authority acceptance of general notes.

DB Contractor Risk. All such Work is performed at the sole risk of the DB Contractor. An ERFC does not release the DB Contractor from any of the design submittal processes described in Technical Provision 2.3.7 and Technical Provision 2.3.8. If, as a result of the review process, the Mobility Authority (at its sole discretion) requires construction modifications or changes to already-completed Work performed under the ERFC, the DB Contractor shall make any and all such construction modifications, removals, or reconfigurations at its sole cost and expense, without any entitlement to time extensions or adjustment in the DB Price.

Mobility Authority Review. Within the timescale specified in Technical Provision 2.3.6, the Mobility Authority will notify the DB Contractor in writing if the ERFC Design Package is accepted or rejected. The Mobility Authority will review for conformance with the Contract Documents. The Mobility Authority will provide only conditional acceptance of ERFC Design Packages. An ERFC Design Package does not represent a complete design. The Mobility Authority can only review ERFC Design Packages for internal consistency as a partial package. Impacts from future submittals and the production of the Final Design Package cannot be anticipated by the Mobility Authority. The DB Contractor shall be obligated to revise the Work as required to address changes as a result of design development until delivery of a Final Design Package acceptable to the Mobility Authority. The Mobility Authority reserves the right to accept or reject any ERFC at its sole discretion.

2.4 Construction Quality Management

The DB Contractor shall maintain a record of construction quality activities and include a summary with the monthly Project Schedule update.

2.4.1 Construction Quality Management Plan (CQMP)

The DB Contractor shall prepare a Construction Quality Management Plan (CQMP) that describes the policies and procedures to manage and ensure the quality of the Construction Work (including that of subcontractors) consisting of construction QC and QA activities and materials acceptance procedures in accordance with the Mobility Authority's *Quality Assurance Program for Design-Build Projects with Agency Acceptance Provisions (QAP)* provided in Exhibit D – Item 1 – General.

The DB Contractor shall prepare and submit a CQMP, for Mobility Authority review and acceptance, based on the draft CQMP submitted in its Proposal that addresses Construction Quality Control (CQC) and how those activities will be coordinated with the Mobility Authority's Material Acceptance. The requirements for the DB Contractor's Construction Quality Control and the Mobility Authority's Material Acceptance are included in the QAP. Mobility Authority acceptance of the CQMP shall be a condition of the commencement of Construction Work.

2.4.1.1 General

DB Contractor Responsibility. The objective of the CQMP is to place the responsibility for conducting CQC duties solely with the DB Contractor while enabling the Mobility Authority to conduct Material Acceptance and MAT. The DB Contractor is responsible to inspect and check all Work prior to releasing to the Mobility Authority for acceptance inspections or tests.

Focus on Quality. The DB Contractor's obligations for Construction Quality Control (CQC) and Construction Quality Assurance (CQA) activities shall comply with the CQMP requirements, supplemented by the Mobility Authority's QAP. The DB Contractor's CQC program includes the internal procedures used by the DB Contractor, suppliers, and subcontractors that will ensure that the Project is delivered in accordance with the RFC Plans, approved shop drawings, working drawings, and specifications. This requires the active and continuous participation of the entire work force; by focusing on achieving construction quality initially, so that rework can be reduced or eliminated.

Role of the CQAM. The Construction Quality Assurance Manager (CQAM) shall oversee the implementation of the CQA program.

Role of the CQCM. The Construction Quality Control Manager (CQCM) shall be responsible for the implementation of the CQMP and oversee all Construction Work and CQC activities.

CQMP Changes. If changes to the CQMP are required after commencement of Construction Work, update the Record of Revisions at the front of the CQMP with the revision number, date of the revision and a description of the revision if changes to the CQMP are required. Only the revised section(s) of the CQMP and applicable procedure(s) are required to be submitted for review and approval.

General Requirements. The DB Contractor's CQC elements shall require as a minimum the following:

- CQC Inspections and tests are performed on a full time basis by qualified Senior CQC Representatives (*Technical Provision 1.1.3*) independent of production Work. The DB Contractor's CQC elements shall employ the use of hold points. A hold point is the point at which a Material Acceptance or material sample and/or test is required before proceeding with that element of Work. Hold points shall be identified by the DB Contractor and approved by Mobility Authority and inserted in the CQMP, CQC Inspection Procedures and CQC Inspection Forms. Hold points shall be identified by the DB Contractor and communicated to the Mobility Authority a minimum of 24-hours in advance of each respective hold point.
- Identification of Material Acceptance and MAT by the Mobility Authority in the CQMP with hold points and must be completed prior to proceeding or continuance of Work by the DB Contractor.
- The levels of CQC/ Material Acceptance of critical elements will be identified in the CQMP accepted by Mobility Authority. At a minimum, the DB Contractor's CQMP shall specify CQC inspections and tests for all items covered by the Mobility Authority acceptance inspections and testing in the Mobility Authority's QAP.

2.4.1.2 Mobility Authority Review

The DB Contractor shall submit a final CQMP to the Mobility Authority at least 40 Business Days before beginning construction activities for Mobility Authority's review and acceptance. The DB Contractor shall not begin any construction activities until the DB Contractor resolves all comments to the satisfaction of the Mobility Authority.

2.4.1.3 CQMP Contents

The DB Contractor shall address the CQMP requirements and prepare the procedures described in QAP Section 2.2.2 provided in Exhibit D – Item 1 - General. The CQMP shall clearly outline the activities for CQC and the benchmarks for Material Acceptance.

The CQMP and associated procedures shall describe and address at least the following:

Authority. Clear definition of the authority and responsibility for administering the DB Contractor's CQC and Mobility Authority's Material Acceptance program.

Work Force Participation. Methods and procedures to obtain active participation of the DB Contractor's work force in CQC activities to achieve a quality project.

Reporting Forms. Reporting forms to be used by the responsible CQC personnel.

Staffing Plan. A CQC organization and staffing plan that includes the period of time that each CQC staff member will be on-site.

Staffing Qualifications. Resumes and applicable certifications of the key staff members and the experience, knowledge, and skill levels of the CQC support staff.

Procedures. Procedures for inspecting, checking, and documenting the Project, for the inspection, examinations, and measurements for each operation (such as demolition, clearing, drainage, grading, surfacing, and paving), and for coordinating with the Material Acceptance staff.

Controlled Conditions. Procedures to ensure that all activities affecting the quality of the Project are accomplished under controlled conditions, using appropriate equipment for the task being performed.

Personnel Standards. Procedures to ensure that the standards of education, training, and certification of personnel performing CQC activities are achieved and maintained.

Critical Elements. Procedures to ensure that critical elements of the Project (such as the deck pour) are not started or continued without acceptance by the Material Acceptance staff.

Conformance and Performance. Specific procedures to ensure that all Work conforms to the requirements of the Contract Documents, Governmental Approvals, applicable Law, and the Design Documents, and that all materials, equipment, and elements of the Project will perform satisfactorily for the purpose intended. Procedures shall include CQC testing processes and minimum testing frequencies.

Compliance Criteria. A requirement that all activities undertaken by or on behalf of the DB Contractor affecting the quality of the Project shall be prescribed and accomplished by documented instructions, procedures, and appropriate drawings, all of which shall include quantitative and qualitative criteria to be used to determine compliance.

Purchase Compliance. Measures that ensure that purchased materials, equipment, and services conform to the Contract Documents, the Governmental Approvals, applicable Laws, rules, regulations, and the Design Document (including measures for source evaluation and selection, provision of objective evidence of quality furnished by subcontractors and suppliers, inspection at the manufacture or vendor source, and examination of products upon delivery).

RFI Procedures. Procedures for processing RFIs to resolve discrepancies and/or questions in the Released-for-Construction Plans so that all changes are documented and approved by the DB Contractor's design engineers. The DB Contractor shall involve the Mobility Authority throughout the entire RFI process.

Coordination. A program for coordination of all inspections and testing with the inspections and tests of Governmental Entities and Utility Owners.

Adverse Conditions. Procedures to ensure that conditions adverse to quality (such as failures, malfunctions, deficiencies, defective material and equipment, deviations, and other Nonconforming Work) are promptly identified and corrected; to ensure that the cause of the condition is determined and prompt corrective action taken to preclude repetition; and to document and report the identification of the significant condition adverse to quality, the cause of the condition, and the corrective action taken be documented in writing to the Mobility Authority and to appropriate levels of the DB Contractor’s management team.

Instrumentation. Procedures and personnel to be used to assure that specified instrumentation is installed and monitored in accordance with applicable specifications.

Certificates of Compliance. The form and distribution of certificates of compliance.

Construction Staking. Procedures for checking and verifying the accuracy and adequacy of construction stakes, lines, and grades established by the DB Contractor.

Nonconforming Work. Procedures for identifying and correcting materials/products and Work that have been determined not to be in compliance with the design or construction requirements (i.e., Nonconformance Report process). Regardless of the corrective action or resolution, the Mobility Authority reserves the right to reject use of materials/products found to be not in compliance.

Inspections, reviews, and testing. Procedures ensuring that only personnel with appropriate training and qualifications, shall perform each appropriate item of Work (items produced on and off the Project Site) using appropriate equipment that is accurately calibrated and maintained in good operating condition and accredited in compliance with the Mobility Authority’s QAP.

2.4.2 Construction Quality Control and Material Acceptance

2.4.2.1 Quality Control Personnel

The DB Contractor’s CQC organization shall, at a minimum, consist of the following individuals.

Construction Quality Assurance Manager. The DB Contractor shall assign an on-site CQA Manager (CQAM) who shall be responsible for development, implementation, and management of the DB Contractor’s CQA program, shall not be involved with scheduling or production activities, and shall report directly to the DB Contractor’s Project Manager. The CQAM shall oversee CQA inspection and testing efforts are implemented and followed by the DB Contractor and subcontractors. The CQAM shall not be involved with design, scheduling, or production activities but has the authority to stop work.

Construction Quality Control Manager. The DB Contractor shall assign an on-site CQC Manager (CQCM) who shall be responsible for management of CQC for the Construction Work and for performing quality control for the DB Contractor. The CQCM will ensure that the methods and procedures as described in the accepted CQMP are implemented and followed by the DB Contractor and any subcontractor(s) of the DB Contractor in the performance of the Construction Work. The CQCM shall not be involved with

design, scheduling, or production activities and shall report directly to the DB Contractor's Project Manager. The CQCM has the authority to stop work. The CQCM must be a Professional Engineer with a minimum ten years' relevant construction quality control management experience on design-build projects of similar type, size, and scope.

The person serving as the CQCM may also simultaneously serve as any of the five (5) identified Category B Key Personnel Senior Construction Inspector roles listed in Technical Provision 1.1.3.

CQC Staff. Each person on the DB Contractor's and subcontractors' construction work force is considered to be a member of the DB Contractor's QC staff, as each and every one is responsible for the quality of the Project. CQC inspections shall be performed on a full time basis by senior CQC representatives independent of production work. Personnel performing quality control sampling, testing, and inspection shall be knowledgeable in the testing and inspection methods and procedures. CQC staff responsible for the quality control of asphalt shall be certified as required in the applicable specifications found in the *TxDOT Standard Specifications of Construction and Maintenance of Highways, Streets, and Bridges*.

2.4.2.2 *Material Acceptance*

The Mobility Authority will perform or cause to be performed the Material Acceptance Testing (MAT).

Material Acceptance Staff. The Mobility Authority will assign MAT personnel to the Project responsible for material sampling/testing, under the direction of the Mobility Authority, of all materials incorporated into the Project by any member of the DB Contractor's group.

2.4.2.3 *Mobility Authority Role during Construction*

The Mobility Authority will perform, at its sole discretion, material acceptance reviews and audits of the DB Contractor's construction quality management operations.

Mobility Authority's Material Acceptance program will consist of the following individuals.

Resident Engineer (RE). An on-site engineer, registered in the State of Texas, responsible for management of the QAP shall be assigned to the Project. The RE has the authority to observe, test, inspect, approve, and accept the Work. The RE decides all questions about the quality and acceptability of materials, Work performed, Work progress, Contract Documents interpretations, and acceptable Contract Documents fulfillment or other procedures requiring the "Engineers' review, approval, acceptance, authorization, examination, interpretation, confirmation, etc." which are contained in the *TxDOT Standard Specifications of Construction and Maintenance of Highways, Streets, and Bridges*, adopted by TxDOT. The RE has the authority to enforce and make effective these decisions.

The RE acts as a referee in all construction questions arising under the terms of the DB Agreement.

Material Acceptance Staff. Material Acceptance personnel will be assigned to the Project responsible for acceptance under the direction of the RE, of all construction activities performed and materials incorporated into the Project by any member of the DB Contractor's group. The Material Acceptance staff will perform acceptance oversight and testing services, with the exception of monitoring tests and means and methods. The Mobility Authority reserves the right to back charge the DB Contractor for failed tests and multiple acceptance retests.

Material Acceptance staff shall provide oversight and perform audits of the quality control inspection and material acceptance sampling/testing operation.

Construction activities requiring continuous field quality acceptance review or sampling and testing, in the sole discretion of the Mobility Authority, shall proceed only in the presence of assigned Material Acceptance personnel. The CQMP shall identify those activities.

Should the Mobility Authority determine that the DB Contractor is not complying with the CQMP due to lack of coordination with the Material Acceptance staff, the Mobility Authority shall have the right, without penalty or cost, including time extensions or delay damages, to restrict Work efforts until appropriate levels of coordination with the Material Acceptance staff are consistent with the CQMP and satisfactory to the Mobility Authority.

2.4.3 Construction Quality Control

The DB Contractor shall perform any and all construction inspections and reviews necessary to provide a quality Project which meets the objectives of the Contract Documents. The DB Contractor is responsible to inspect and check all Work prior to releasing to the Mobility Authority for acceptance inspection or testing.

At a minimum, the QC inspections and testing shall meet the following requirements:

- Prior to being implemented into the Work, the DB Contractor shall provide all Portland cement concrete and hot-mix asphalt concrete mix designs in accordance *TxDOT Standard Specifications for Construction and Maintenance of Highways, Streets, and Bridges*, to the Mobility Authority for approval.
- Designation by the DB Contractor and each supplier and subcontractor of a Senior Quality Control Inspector to perform daily field inspections of Project materials and Work, and preparation of a daily CQC report to document the inspections.
- Sampling and testing of all materials during the crushing, screening, or manufacturing processes so that only materials meeting the specifications are supplied for ultimate incorporation into the Project.
- Establishment of a systematic approach to the Project that defines all requirements for processes, procedures, and documentation.

2.4.4 Mobility Authority Material Acceptance

Definition. The Mobility Authority’s Material Acceptance program shall include the following:

Material Acceptance:

Review of all Project elements to verify and document that the Project has been constructed in conformance with the RFC and ERFC plans, specifications, and approved working and shop drawings.

Authority to stop a specific activity of the Project if (in the opinion of the RE) the CQMP is not being implemented correctly

Audit of the DB Contractor’s records, documentation, procedures, and processes to verify compliance with the accepted CQMP. Audit results shall be documented, reviewed, and acted upon by the DB Contractor. Follow-up action, including re-audit of deficient areas following corrective action, shall be taken where indicated.

Material Acceptance Testing:

Review and approval of all Portland cement concrete and hot-mix asphalt concrete mix designs by a Registered Professional Engineer.

The Mobility Authority will perform material sampling and testing at the point of acceptance in accordance with TxDOT’s *Construction Contract Administration Manual*, *Manual of Testing Procedures*, *Material Inspection Guide*, and the Mobility Authority’s *Guide Schedule, Minimum Sampling and Testing For Design-Build Projects*.

Codify the material inspections and testing similar to that used by TxDOT’s Construction Division – Materials and Pavement Section (CSTM&P).

In accordance with TxDOT procedures, material inspection and testing of materials/products supplied by manufacturers or producers approved by TxDOT for use on TxDOT projects (i.e., materials from a TxDOT approved list) will not be required unless the quality of the job site material is questioned. The Mobility Authority reserves the right to independently test samples to verify compliance with the construction requirements.

Inspection and Testing by Others. When any Governmental Entity or Utility Owner is to accept or pay for a portion of the cost of the Project, its respective representative(s) shall also have the right to inspect such Project. Such inspection does not make such person a party to the DB Agreement or a beneficiary of any of the rights and obligations hereunder, nor will it change the rights and obligations of the DB Contractor or the Mobility Authority under the Contract Documents.

Uncovering of Finished Project. If the Mobility Authority is not given adequate notice of and/or the opportunity for prior Material Acceptance of any DB Work done or materials used, then the Mobility Authority may order that such DB Work or materials be uncovered, removed, or restored at the DB Contractor's expense, and the DB Contractor shall not be entitled to a time extension, even if the DB Work proves to conform with the requirements of the Contract Documents, the Governmental Approvals, and applicable Law after uncovering.

2.4.5 Independent Assurance and Testing Dispute Resolution

Independent Assurance: The technician testing certification and laboratory equipment calibration will be performed by TxDOT or an Independent Assurance laboratory certified by TxDOT.

Testing Dispute Resolution System: When Mobility Authority acceptance test results differ from that of the DB Contractor CQC test results, testing disputes shall be elevated to a referee laboratory and shall be resolved by the referee laboratory. The referee laboratory shall be TxDOT or a Testing Firm approved jointly by the DB Contractor and the Mobility Authority. The referee laboratory shall perform testing or evaluation in a reliable, unbiased manner. The decision by the referee laboratory shall be final.

Fees: Any fees charged for the Independent Assurance certifications for the DB Contractor material testing program and testing dispute resolution will be the responsibility of the DB Contractor. Any fees associated with the referee laboratory will be split evenly between the DB Contractor and the Mobility Authority. The DB Contractor will pay the fees in total, and subsequently include the Mobility Authority's portion of the fees in the applicable Draw Request.

2.4.6 Material Inspection and Testing

Weekly Inspection Notices. On a weekly basis, the DB Contractor shall provide the Mobility Authority, with a rolling 3-week inspection notice. At a minimum, the inspection notification shall detail the fabrication schedule and planned construction activities.

Advance Notice. Contractor shall provide notice by 2:00 PM the day before any hold-point inspections or operations requiring QA testing.

Failure to provide the Mobility Authority with adequate notice as specified above may result in the Mobility Authority failure to schedule resources, in which case the Mobility Authority shall be entitled to withhold a portion of the DB Contractor's progress payments.

2.4.7 Reporting, Record-Keeping, and Documentation

The DB Contractor shall maintain construction workmanship and materials quality records of all CQC inspections and tests performed per the accepted CQMP, and report results to the RE.

General Content. These records shall include factual evidence that the required CQC inspections and tests have been performed, including the type and number of CQC inspections involved; the results of CQC inspections; the nature of defects, deviations, causes for rejection, etc.; proposed remedial action(s); and corrective actions taken. These records shall cover both conforming and defective or deficient features, and shall include a statement that all supplies and materials incorporated in the Work are in full compliance with the terms of the Contract Documents.

Weekly Construction Schedule. These records shall be made available to the Mobility Authority in format and content as specified in the CQMP. The DB Contractor shall provide to the Mobility Authority specific construction schedule activities (including location and planned quantities) on a weekly basis to enhance coordination of the Mobility Authority's Material Acceptance activities.

Specific Content. Requirements for the DB Contractor's CQC inspection records shall include, but are not necessarily limited to, the following:

Reports and Results. Quality Control inspection reports, in electronic format, shall be submitted to the Mobility Authority within 24 hours following the inspection or test. Quality control inspection reports and material sampling/testing results shall be updated within 48 hours following the inspection or test and be available for the Mobility Authority review or audit.

Daily Logs. The CQAM shall maintain (in an electronic format acceptable to the Mobility Authority) a daily log of all QC inspections performed for both the DB Contractor and subcontractor operations. These daily QC inspection logs shall document the day's events, activities, and discussions by identifying all inspections conducted, results of CQC inspections, location and nature of defects found, causes for rejection, and remedial or corrective actions taken or proposed. The responsible technician and his/her supervisor shall sign the daily QC inspection logs. The logs shall be accessible to the Mobility Authority at the end of each work shift.

Electronic Reports. The CQAM shall establish an electronic system for recording all QC inspection and material test results consistent with Mobility Authority requirements. Preliminary QC inspection and test results from each day's work period shall be signed by the responsible technician and his/her supervisor, and electronically transmitted to the Mobility Authority. The results of the daily QC inspection shall be provided within 5 Business Days of the day of record. In addition, weekly summary status reports shall also be provided within 5 Business Days.

Database Format. The CQC's inspection shall electronically deliver the QC results to the Mobility Authority in a database format. The DB Contractor and the Mobility Authority, prior to construction testing, shall agree upon the format for this database.

2.4.8 Requirements of Laboratories

Certification. Staff must comply with the requirements of the AASHTO's Accreditation Program (AAP) or other appropriate certification acceptable to the Mobility Authority and must be certified for the pertinent test. Sampling and testing personnel must obtain and keep current the following certifications unless otherwise waived by governing specifications:

- ACI Concrete Field Testing Technician – Field Grade I
- ACI Concrete Strength Testing Technician
- TxAPA HMA Plant Production Specialist – Level 1A
- TxAPA HMA Roadway Specialist – Level 1B
- TxAPA HMA Mix Design Specialist – Level 2
- TxAPA Properties Specialist – SB 101
- TxAPA Field Specialist – SB 102
- TxAPA Materials Analysis Specialist – SB 103
- TxAPA Strength Specialist – SB 201
- TxAPA Compressive Strength Specialist – SB 202

Reciprocity may be granted to individuals who have been successfully qualified under another state's program. These situations will be considered on a case-by-case basis and must meet the approval of the Mobility Authority. A copy of certificate(s) shall be transmitted to the Mobility Authority upon their receipt by the testing laboratory.

2.4.9 Source and Quality of Materials

The quality of all materials shall conform to the Mobility Authority's requirements, as contained in the Contract Documents. Manufacturers' test reports may supplement, but not replace, the CQC inspections, CQC sampling and testing, MAT and certification provisions.

TxDOT Services. The Mobility Authority has entered into an Interlocal Agreement with the Texas Department of Transportation to provide for material testing and inspection services at points in Texas where the State routinely provides resident inspection services for its own highway materials and at other locations throughout the contiguous United States.

Three weeks prior to TxDOT performing any inspections, the DB Contractor shall prepare work orders, which will be issued by the Mobility Authority to TxDOT for execution. Each work order will include the following information:

- Project Information (i.e., contract number, project control numbers, etc.).

- Work Description.
- Type and quantity of highway material(s) to be tested and/or inspected.
- One (1) copy of the appropriate design documents, including plans, special provisions, supplemental specifications, and notes.
- Two sets of approved shop drawings to the fabricator's location, one of which is specifically to be stamped "For TxDOT Use." Shop drawings submittals must be complete and clearly indicate any special fabrication requirements.
- Assigned fabrication for each highway material including: the fabricator's location, contact, and phone number.
- Date inspection should occur.
- Signature and telephone number of authorized Mobility Authority and the DB Contractor representatives.

A supplemental work order will be required when changes are made to the work order.

Random Testing. When material that cannot be identified by specific test reports is proposed for use, the RE will select random samples from the lot for testing by the DB Contractor. The RE shall determine the number of such samples and test specimens.

Furnishing of Samples. If requested by the Mobility Authority, the DB Contractor shall furnish to the Mobility Authority samples of materials to be incorporated into the Project. The DB Contractor shall use no material that is subject to such a request without written authorization by the Mobility Authority to proceed. Manufacturers' Warranties, guarantees, instruction sheets, parts lists, and other materials that are furnished with articles or materials incorporated into the Project shall be made available to the Mobility Authority upon request.

Mobility Authority Inspections. The Mobility Authority may, at its sole discretion, inspect the production of all material or the manufacture of products at the source of supply, except for materials that are routinely accepted by manufacturers' certificates of compliance. The Mobility Authority shall have free entry at all reasonable times to such parts of the plant relating to the manufacture or production of materials. The Mobility Authority shall assume no obligation to inspect materials at the source of supply, but will perform inspections at times and frequencies that the Mobility Authority determines are in its own best interest.

2.4.10 Access to Testing Facilities

The Mobility Authority reserves the right to check testing equipment, procedures, and techniques for compliance with the Mobility Authority's and AASHTO's test methods, equipment requirements, and calibration standards. The Mobility Authority also reserves the right to access the testing facilities to witness the testing, and to verify compliance of the testing procedures, techniques, and results.

2.4.11 Nonconformance Report

The DB Contractor shall identify, document, and report to the Mobility Authority any instance of Nonconforming Work. This reporting shall be compiled by the CQAM and shall be in the form of a Nonconformance Report (NCR).

Submittal. The NCR shall be submitted to the Mobility Authority in writing within 24 hours of the DB Contractor obtaining knowledge of the same. The DB Contractor shall simultaneously send a copy of each NCR to the Design Manager, or designee, and the Mobility Authority.

Contents. The NCR shall clearly describe the element of the DB Work that is nonconforming and the reason for the nonconformance. The DB Contractor's Design Engineer who certified and sealed the drawings for the DB Work shall evaluate the effect of the nonconformance on the performance, safety, durability, and long-term maintenance of both the Project and the specific element affected. If the Design Engineer or the Mobility Authority determines that remedial action is necessary, the proposed remedial action shall be documented and bear the stamp of the original responsible Professional Engineer. The DB Contractor's Design Manager, or designee, and the Mobility Authority must also sign off on the NCR stating that the remedial actions to be employed have undergone the same level of design QC/QA as the DB Work design.

Record-Keeping and Closure. The RE will maintain a log of all NCRs. Each NCR will be numbered sequentially, given a brief description, a status and, if it is not closed, an expected date for closure. All NCRs must be closed with the stamp of Design Firm's qualified engineer in charge or the responsible Registered Professional Engineer from the same firm assigned to replace the original one and Mobility Authority approval. The Mobility Authority will not grant Final Acceptance for the Project if there is an outstanding NCR.

Mobility Authority Role. The Mobility Authority shall have the authority to require the removal of any Nonconforming Work. The Mobility Authority shall also retain the right to write its own NCRs. NCRs generated by the Mobility Authority shall require the same review and ultimate closure by the DB Contractor as an NCR prepared by the DB Contractor.

Cost Adjustments. The Mobility Authority reserves the right to make cost adjustments for the DB Contractor Work that, although not in conformance with plans and specifications, Contract Documents, the Governmental Approvals, or applicable Law, and is nevertheless permitted by the Mobility Authority to remain in place.

2.4.12 Construction Documentation

The DB Contractor shall maintain in a secure place at the construction field office one record copy of all drawings, specifications, addenda, amendments, Change Orders, CQC material sampling and test reports, CQC inspectors reports, RFIs, NCRs, written interpretations, and clarifications, all in good order and

annotated to show changes made during construction. These documents, as well as all approved samples and approved shop drawings, shall be available at all times to the Mobility Authority.

2.4.12.1 General Requirements

Required Data. During performance of the Project, the DB Contractor shall collect and preserve the following data, at a minimum, in written form acceptable to the Mobility Authority:

- Daily manpower and equipment reports for the DB Contractor and each subcontractor for construction-related activities.
- Daily occurrence logs for construction-related activities, recording in narrative form all significant occurrences on the Project, including:
 - Unusual weather.
 - Asserted Force Majeure events.
 - Events and conditions causing or threatening to cause any significant delay or disruption or interference with the progress of the DB Work.
 - Significant injuries to person or property.
 - A listing of each activity depicted on the current Project Schedule status submittal that is being actively prosecuted.
 - A daily record in a standard format recording all labor, materials, and equipment expenses that are being incurred.

CQC. The DB Contractor shall maintain quality records documenting all CQC operations, CQC inspections, activities, and CQC tests performed, including the CQC elements performed by subcontractors. Such records shall include any delays encountered and a list of any Nonconforming Work, together with the corrective actions taken.

Utilities. For any Governmental Entity betterments or Utility Adjustment Work, such data shall be maintained separately for each Governmental Entity or Utility.

Hazardous Materials. For the Hazardous Materials management Work element, such data shall be maintained separately for each area in which Hazardous Materials management Work is performed.

Future Claims. If it becomes necessary to undertake Work for which a Change Order has not been executed or that may be the subject of a future claim, the DB Contractor shall identify this Work on separate daily occurrence logs.

Monthly Certifications. The DB Contractor shall maintain a monthly written certification in accordance with Section 13.3.4 of the DBA.

Certificates of Compliance. Materials certificate of compliance at Final Acceptance of the Project will be submitted by the Mobility Authority.

2.4.12.2 Shop and Working Drawings

The DB Contractor’s design engineers shall review, approve, authorize, and confirm any methods or procedures that are contained in the latest edition of the TxDOT *Standard Specifications for Construction and Maintenance of Highways, Streets, and Bridges*, adopted by TxDOT in November 2014 and then submit the certified and sealed design drawings to the DB Contractor’s construction team. The construction team shall then generate shop and working drawings as necessary to clearly define, control, construct, and inspect the Project. These working drawings shall be sent back to the design team for review. All such drawings shall be reviewed by qualified personnel, and shall be stamped “Approved for Construction.” Working drawings requiring signing and sealing per the TxDOT *Standard Specifications for Construction and Maintenance of Highways, Streets, and Bridges*, adopted by TxDOT in November 2014 shall be signed and sealed by a Registered Professional Engineer, prior to being issued for construction.

Other Approvals. The DB Contractor shall provide the Mobility Authority and all other applicable Governmental Entities copies of the preliminary and final shop and working drawings and shall coordinate the preparation, submittal, and review of all such shop and working drawings. Where Governmental Approvals or approvals from Utility Owners are required, shop and working drawings shall be submitted to the applicable party for review and approval in accordance with its requirements.

Contents. Shop and working drawings for the Project shall include structural steel fabrication plans, anchor bolt layouts, shop details, erection plans, equipment lists, and any other information specifically required by the CQMP, TxDOT *Standard Specifications for Construction and Maintenance of Highways, Streets, and Bridges*, adopted by TxDOT in November 2014 or other Governmental Entities.

Temporary Work. Shop and working drawings and calculations for excavation shoring, cribs, cofferdams, falsework, overhead signs, temporary support systems, formwork, and other temporary Project elements that describe the methods of construction proposed to be used for the Project shall be prepared by the DB Contractor in accordance with the DQMP. The Mobility Authority will not review or regularly receive copies of these submittals unless it specifically requests such documents. Receipt of submittals for temporary Project elements by the Mobility Authority shall in no way constitute approval of the planned Project element or impose any liability upon the Mobility Authority.

Submittal to Mobility Authority. Approved shop or working drawings shall be made available to the Mobility Authority at least 5 Business Days prior to the start of any DB Work detailed by those drawings. The DB Contractor shall make no changes in any approved shop or working drawing after the design engineer has approved them. Any deviations from approved shop or working drawings shall require the fabricator to submit revised drawings to the DB Contractor’s design engineers for their approval, as outlined above.

2.4.12.3 Record Drawings

As a condition to Final Acceptance of the Project, the DB Contractor shall provide to the Mobility Authority the Project’s Record Drawings, consisting of two hard-copy sets, one electronic file of each plan in .pdf format, one electronic file in MicroStation .dgn format of the Record Drawings, and design feature file Geodatabase, sign images and GPS files and accuracy reports delivered on DVD or external hard drive.

Contents. These Record Drawings shall depict the final completed Project, including all changes and data showing the electrical systems, drainage systems, lighting systems, underground Utilities, traffic controls, intelligent transportation system, signing placement, shop plans, highway alignment and grade revisions, bridge detail changes, bridge settlement reference elevations and joint seal measurements, typical sections and cross sections and all other relevant data, including any operations and maintenance manuals for the mechanical and electrical systems.

Table 2-2: Features and Feature Types

Features	Feature Type
Bridges	Point
Barriers	Line
Attenuator	Point
Guardrail Terminal	Point
Sidewalk	Line
Shared Use Path	Line
Curb	Line
Toll Gantry	Point, Line
ITS Pole	Point
Culvert Headwalls	Polygon
Inlets	Point
Illumination Pole	Point
UCV Box	Point
Rip Rap	Polygon
Retaining Walls	Line
Landscape	Polygon for outside limits of landscape area
Signs Supports	Point or Multipoint, if more than one support
Signs-Large	SignLarge Point UID corresponding to SupportSign Large point feature
Signs-Small	SignSmall Point UID corresponding to SupportSign Small point feature

The design features in ArcGIS feature classes are to be used with a mapping or survey grade GPS collection application so that the horizontal positions can be verified and corrected in the field. The DB Contractor will provide collection or post-processing at an accuracy level of 2 meters or less for 95% of the design features.

Results of GPS collection and/or post-processing are to be further edited using ArcGIS desktop to ensure proper data integrity of the linear and polygon design features. This process will correct any linear or polygon feature design issues that may have been introduced during the GPS collection or post-processing of the GPS data. In order to fulfill this requirement, line and polygon topology will be generated, validated and corrected, as necessary, using the following rules:

Line topology rules:

- Must Not Overlap – line features from one layer must not overlap lines from the same layer.
- Must Not Intersect – lines features must not intersect or overlap lines from the same layer.
- Must Not Self-Overlap – line features from one layer must not intersect or overlap itself.
- Must Not Self Intersect – line features from one layer must not intersect itself.
- Must Be Single Part – line features from one layer must not have more than one part.

Polygon topology rules:

- Must Not Overlap – area features must not overlap another area from the same layer.

The following are GIS and GPS as-built delivery requirements:

- Raw GPS collection files in native format.
- Corrected or post-processed GPS files in native format. Include horizontal positional accuracy reports for each GPS collection file.
- Final design features will be in a single Esri File Geodatabase format using 10.1 or earlier version.
- All feature classes and datasets will use Texas State Plane grid coordinates, NAD83, Central Zone with units in U.S. Survey Feet.
- All feature classes must be 2D only without enabled Z or M geometry coordinate values.
- All feature classes, datasets and topologies will use an XY resolution and topology cluster tolerance of 0.003280833333333 U.S. Survey feet.
- Horizontal positional accuracy of design features must be at an accuracy level of 2 meters or less for 95% of all design features.
- Linear and polygon design features must have validated topologies without errors.
- All feature classes must have complete metadata for the following sections:
 - Item Description (Summary, Description, Credits, and Use Limitation).
 - Metadata Contacts.

- Resource (Constraints, Data Quality, Lineage, and Fields).
- Design feature File Geodatabase, sign images and GPS files and accuracy reports will be delivered on DVD or external hard drive.

Bridge Plans. The Record Drawings relating to bridges shall show the actual profile grade elevations at each substructure centerline and the tip elevation of drilled shafts or pile foundations on the bridge layouts. The DB Contractor shall obtain and record actual beam seat elevations prior to placing beams or girders.

Signoff. The DB Contractor’s Engineer of Record shall sign, seal, and date the title sheet of the Record Drawings and certify that the Project was completed in accordance with the plans, the Contract Documents, the Governmental Approvals, and applicable Law.

2.5 Submittals

Table 2-3: Submittals to Mobility Authority

Submittals	Submittal Schedule	Mobility Authority Action	Reference Section
Quality Management Plan (QMP)	Condition for issuance of NTP 2	Review and Acceptance	2.1.3
Design Quality Management Plan (DQMP)	20 days after NTP 1	Review and Comment	2.3.1.2
Project 3-D Design Model	At least 5 Business Days prior to each in-progress workshop	Information and Review	2.3.5.2
In-progress Design Workshop Meeting Minutes	Within 5 Business Days after the in-progress workshop	Information	2.3.5.2
Preliminary (30%) Design Submittal	As specified in Project Schedule	Review and Acceptance	2.3.6
Intermediate (65%) Design Submittal	As specified in Project Schedule	Review and Acceptance	2.3.6
Final (100%) Design Submittal	As specified in Project Schedule	Review and Acceptance	2.3.6
Design submittal notice	10 Business Days prior to any design submittal	Information	2.3.6
Released-for-Construction (RFC)	Prior to commencement of construction	Review and Acceptance	2.3.10

Submittals	Submittal Schedule	Mobility Authority Action	Reference Section
Early Release for Construction (ERFC)	Prior to commencement of construction	Review and Acceptance	2.3.12
Construction Quality Management Plan (CQMP)	40 Business Days before beginning construction activities	Review and Acceptance	2.4.1
Approved Shop and Working Drawings	5 Business Days prior to the start of any DB Work detailed by those drawings	Information	2.4.12.2

3.0 WARRANTIES

The Mobility Authority requires Warranties on construction items to help ensure both the initial and long-term quality of the Project's products, workmanship, and materials.

The Warranties shall also apply to all Work redone, repaired, corrected or replaced after Final Acceptance. Following acceptance by the Mobility Authority of redone, repaired, corrected or replaced Work the Warranties shall apply for the longer of (i) the remainder of the Warranty term, or (ii) 1 year from the date of acceptance by the Mobility Authority of the repaired, replaced, or corrected Work.

Any incidental Work associated with the redone, repaired, corrected or replaced Work to restore the Project to Final Acceptance condition performed under the Warranty shall be included as part of the Warranty.

Liquidated Damages identified in *Technical Provision 22* apply to closures during Warranty Work. Closure of the lanes for Warranty Work shall be subject to the lane closure restrictions in *Technical Provision 22*.

3.1 Referenced Standards and Guidelines

The DB Contractor shall meet all material requirements identified in the TxDOT *Standard Specifications for Construction and Maintenance of Highways, Streets, and Bridges*, adopted by TxDOT in November 2014.

3.2 Summary of Project Warranties

The DB Contractor shall warranty the Work in accordance with the Contract Documents. The Warranties must remain in effect until the times specified in **Table 3-1** (*Summary of Project Warranties*). Warranty periods for all Work shall commence upon Final Acceptance. All Warranties longer than 2 years are performance Warranties and the performance specifications related to such performance Warranties are set forth in *Technical Provisions 3.4.1 through 3.4.6* hereof.

Table 3-1: Summary of Project Warranties

General Subject	Warranty Period
Flexible Pavement: New Constructed Hot-Mix Asphalt - Pavement Failure in Surface/Base	5 years
Flexible Pavement: New Constructed Hot-Mix Asphalt - Cracking, Raveling, Flushing, Rutting, and Popouts	3 years
Rigid Pavement: New Concrete - Cracking, Joint Deficiencies, Punch-Outs, and Surface Defects	5 years
Structural Concrete	5 years
Steel Paint Systems	5 years
Concrete Sealer Systems	5 years
Differential Settlement of New Roadway Grade	5 years
Settlement and Deflection: Sound, Retaining, Neighborhood Walls and Barriers	5 years
Signing (Permanent)	2 years
Traffic Signals	2 years
Lighting	2 years
Utilities -DB Contractor directed Utility Relocations	2 years
Buildings, Toll Facilities, and Related Facilities	2 years
Pavement Markings and Flexible Delineators	2 years

3.3 Warranty Requirements

The DB Contractor shall provide Warranties to the Mobility Authority against defects in materials and workmanship.

Definitions. Related to Warranties, the following definitions shall apply:

Final Acceptance (FA): The date on which the occurrence of all the events and satisfaction of all the conditions set forth in Section 20.2 of the DBA occurs. This date constitutes the start of the Warranty period for all Work.

Final Warranty Acceptance (FWA): The date that defines the completion of the 5-year Warranty period, and the date upon which the Warranty Bond must be released by the Mobility Authority. Acceptance will occur as soon as the Mobility Authority has determined that the Contract Document requirements have been met for the Warranty Work.

3.3.1 Final Warranty Acceptance (FWA)

The Mobility Authority and the DB Contractor must jointly review all completed Warranty Work or a portion thereof, as determined by the Mobility Authority. If the Work does not meet the requirements of the Contract Documents as determined by the Mobility Authority, the DB Contractor must make all necessary corrections, at its own expense, before acceptance. The date on which acceptance occurs is termed the date of FWA.

Exclusion for Corrections. The Mobility Authority may accept the Work and begin the Warranty period, excluding any area needing corrective Work, to accommodate limitations or staged construction.

Disclaimer. Neither the Final Acceptance nor any prior inspection, acceptance, or approval by the Mobility Authority diminishes the DB Contractor's responsibility under this Warranty.

Documentation. The DB Contractor shall document the FWA and execute jointly with the Mobility Authority on a form furnished by the Mobility Authority. The Mobility Authority will send a copy of the form to the DB Contractor's Warranty Bond surety agent.

Material. Acceptance of material in penalty will not relieve the DB Contractor from the responsibility of meeting the material and workmanship Warranty requirements for the accepted material.

3.3.2 Warranty Bond

Amount and Term. The DB Contractor shall furnish a single-term Warranty Bond in the amount designated in the Contract Documents. The effective starting date of the Warranty Bond must be the date of Final Acceptance. The Warranty Bond will be released at the end of the Warranty period (at FWA) or after all Warranty Work has been completed and accepted, whichever is latest.

3.3.3 Rights and Responsibilities of the Mobility Authority

3.3.3.1 Mobility Authority Rights

The Mobility Authority reserves the right to:

- Approve the schedule proposed by the DB Contractor to perform Warranty Work.
- Approve all materials and specifications used in the Warranty Work.
- Determine whether Warranty Work performed by the DB Contractor meets the Contract Document specifications.
- Perform, or have performed, routine maintenance during the Warranty period, which routine maintenance will not diminish the DB Contractor's responsibility under the Warranty.
- Perform, or have performed, emergency repairs under certain conditions, as specified in Section 12.1.5 of the DBA.

3.3.3.2 Mobility Authority Responsibilities

It is the responsibility of the Mobility Authority to:

- Monitor the Project throughout the Warranty period and (annually or as determined by the Mobility Authority) provide the DB Contractor formal written reports on the Project related to the Warranty requirements.

- Communicate the Warranty requirements and the quality of the Warranty Work to be performed by the DB Contractor.
- Notify the DB Contractor, in writing, of any corrective action required to meet the Warranty requirements.

3.3.4 Responsibilities of the DB Contractor

The DB Contractor shall:

- Warrant to the Mobility Authority that the warranted Work is free of defects in materials and workmanship.
- Perform all temporary or emergency repairs that are necessitated by non-compliance with the Warranty requirements or determined by the Mobility Authority to have been caused by defective materials and/or workmanship, using Mobility Authority approved materials and methods.
- Notify the Mobility Authority and submit a written plan for performing the needed Warranty Work at least 10 Business Days before starting Warranty Work, except in case of emergency repairs as detailed in this *Technical Provision 3*. The submittal must propose a schedule for performing the Warranty Work and the materials and methods to be used, including a traffic control plan (TCP).
- Follow a DB Contractor prepared and Mobility Authority accepted TCP when performing Warranty Work.
- Schedule non-emergency Warranty Work during non-peak-hour traffic and as approved by the Mobility Authority.
- Supply to the Mobility Authority original documentation that all insurance required by the Contract Documents is in effect during the period that Warranty Work is being performed. This shall include Railroad protective liability coverage, when necessary.
- Complete all Warranty Work before conclusion of the Warranty period, or as otherwise agreed to by the Mobility Authority.
- Be liable during the Warranty period in the same manner as contractors currently are liable for their construction-related activities with the Mobility Authority pursuant to the latest edition of the TxDOT *Standard Specifications for Construction and Maintenance of Highways, Streets, and Bridges*, adopted by TxDOT in November 2014. This liability arises and continues only during the period when the DB Contractor is performing Warranty Work. This liability is in addition to the DB Contractor performing and/or paying for any required Warranty Work, and must include liability for injuries and/or damages and for any expenses resulting there from that are not attributable to normal wear and tear of traffic and weather, but are due to noncompliant materials, faulty workmanship, and/or the operations of the DB Contractor.

- Within 7 Days of receipt of notice from the Mobility Authority specifying a failure of any DB Contractor Work to satisfy the Warranties, the DB Contractor and the Mobility Authority shall mutually agree when and how the DB Contractor shall remedy such violation; provided, however, that in the case of an emergency requiring immediate curative action, the DB Contractor shall implement such action as it deems necessary and shall immediately notify the Mobility Authority in writing of the emergency.

3.3.5 Evaluation Method

Segmentation. The Mobility Authority will measure and quantify Project condition parameters by evaluating certain selected segments of the Project. A segment is defined as any consecutive 500-foot section of driving lane and/or shoulder. The segmentation scheme (i.e., the segment termini) and the segments selected for evaluation will vary according to the condition parameter being evaluated.

Method. Evaluation will include use of the TxDOT's pavement management information system (PMIS) and/or field pavement condition reviews.

Waiver. This evaluation may be waived by the Mobility Authority in emergency situations.

3.3.6 Corrective Action Requirements

Segment Criteria. Warranty Work will be required as a result of certain defects in materials and/or workmanship. If 50% or more of the evaluated segments in any mile exceed the threshold limits, the entire mile will require corrective action; otherwise, only the affected segments will require corrective action.

Thresholds. The specific thresholds for corrective action are shown in tables in this Technical Provision 3.

Investigations. To determine whether the failure to meet the Warranty criteria is a result of defects in materials and/or workmanship, a Mobility Authority scheduled annual field investigation will be conducted jointly by the Mobility Authority and the DB Contractor. The Mobility Authority and/or the DB Contractor may, if mutually agreed upon, elect a third party to conduct a forensic investigation of the failure. The results of any such investigation shall be final and binding. The decision to undertake a forensic investigation, the scope of it, and the selection of the party to conduct it shall be determined jointly by the Mobility Authority and the DB Contractor. All costs of the forensic investigation shall be shared proportionately, based on the determined cause of the condition as related to the materials and workmanship as stated in the Contract Documents.

Non-warranted Conditions. During the Warranty period, the DB Contractor will not be held responsible for distresses that are caused by identifiable factors unrelated to materials and workmanship. These include, but are not limited to, chemical and fuel spills, vehicle fires, and destructive testing done by the Mobility Authority during the Warranty period. Upon written request from the DB Contractor and on a case-by-case basis, the Mobility Authority will consider other factors that appear to be beyond the control of the DB Contractor.

Time Requirements for Corrective Action. The DB Contractor shall undertake corrective action Work within 20 Business Days after notice by the Mobility Authority of acceptance of the written plan for Warranty correction. If the Work cannot be started then because of limitations, the DB Contractor must so notify the Mobility Authority and submit (for Mobility Authority approval) a schedule for completion of the corrective action Work. Failure by the DB Contractor to respond to the Mobility Authority or undertake corrective action within the specified period of time will be cause for the Mobility Authority to undertake the corrective action Work itself and recover the costs of such Work from the Warranty Bond.

3.3.7 Emergency Repairs

Emergency repairs will be addressed as outlined in Technical Provision 3.3.3.1.

3.4 Warranty Specifications

The DB Contractor shall warrant its workmanship and materials as specified herein.

3.4.1 Flexible Pavement: New Constructed Hot-Mix Asphalt

Application. This section applies to pavement Warranties on new and reconstructed hot-mix asphalt (HMA) pavement placed on an unbound or stabilized aggregate base. Distress identification must be according to the latest methods used by TxDOT, specifically the latest version of TxDOT Pavement Management Information System (PMIS) rater’s manual, except all travel lanes and shoulders will be evaluated every 500 feet and the following definitions shall be used.

Limits of Warranted Work. The warranted Work shall include all HMA on driving lanes and shoulders within the Project limits.

Condition Parameters. Condition parameters are used to measure the performance of the HMA pavement during the Warranty term. Each condition parameter has a threshold level applied to each segment and a maximum number of defective segments allowed before corrective action (Warranty Work) is required.

Definitions:

Transverse Cracking: A crack that is predominantly perpendicular to the pavement

Longitudinal Cracking or Open Joint: A crack that is predominantly parallel to the pavement centerline

Block Cracking: A pattern of cracks that divides the pavement into approximately rectangular areas that range in approximate size from 1 to 100 square feet

Alligator Cracking: A series of interconnected cracks in the early stages of development, evolving into many-sided, sharp-angled pieces, usually less than 1 foot on the longest side, with a characteristic chicken-wire or alligator pattern

Debonding: A physical separation of the new pavement surface from the underlying pavement surface (visually identified by shoving or the loss of new surface course); includes surface potholes (regardless of depth) to the extent derived from debonding of the new surface course

Raveling: Wearing away of the HMA pavement surface caused by the dislodging of aggregate particles and loss of asphalt binder

Flushing: Excess bituminous binder on the pavement surface, which may cause a shiny glasslike reflective surface that may be tacky to the touch; usually found in the wheel paths

Popout: A small piece of pavement or aggregate greater than ¼ inch in diameter that has broken loose from the surface

Rutting: A longitudinal surface depression in the wheel path; may have associated transverse displacement

Failure: Where the underlying materials of the surface or base migrates to the surface resulting in pavement displacement

Threshold Limits. Table 3-2 lists the allowable threshold limit for each condition parameter within each Project segment. If any threshold limit is exceeded as a result of a defect in materials and/or workmanship, corrective action (Warranty Work) will be required. The defective segments for surface distress do not have to be contiguous to necessitate corrective action. Each driving lane and shoulder must be evaluated independently. Any pavement surface requiring removal or replacement to correct deficiencies for any condition parameter must be placed full-width across the driving lane or shoulder.

Corrective Actions. Table 3-2 suggests corrective actions to illustrate acceptable treatments for the various condition parameters. The Mobility Authority will accept the listed corrective action if the action addresses the cause of the distress. The DB Contractor may implement the Mobility Authority suggested corrective action or an alternative, subject to Mobility Authority approval.

**Table 3-2: Threshold Limit & Corrective Action – New Constructed Hot-Mix Asphalt Pavement
(for any consecutive 500-foot segment)**

Condition Parameter	Segment Threshold Limits*	Recommended Action
Transverse Cracking	5 cracks per segment, each greater than or equal to 6 feet long and greater than or equal to 1/8 inch wide	Mill and overlay ¹
Longitudinal Cracking	Greater than or equal to 1/8-inch wide totaling 5% of the segment length	Mill and overlay ¹
Block Cracking	None allowed	Mill and overlay
Alligator Cracking	None allowed	Repair to full depth and resurface
Debonding	None allowed	Mill and overlay
Raveling	1% of the segment area	Mill and overlay
Flushing	1% of the segment length	Mill and overlay
Popouts	15 per square yard	Mill and overlay
Rutting	Average rut depth of 0.5 inch	Mill and overlay.
Failures	None allowed	DB Contractor to provide proposed action ²

*12-foot lane or shoulder width for any consecutive 500-foot segment

¹ Cracks greater than 1 inch wide will be considered failures.

² Recommended action must be approved by the Mobility Authority.

3.4.2 Rigid Pavement: New Concrete

Application. This *Technical Provision 3* applies to pavement Warranties on new concrete pavement placed on an unbound or stabilized aggregate base course. Distress identification must be according to the SHRP Distress Identification Manual for the Long-Term Pavement Performance Project and the following definitions.

Limits of Warranted Work. The warranted Work shall include all concrete pavement on driving lanes, ramps, and shoulders within the Project limits.

Condition Parameters. Condition parameters are used to measure the performance of the concrete pavement during the Warranty term. Each condition parameter has a threshold level applied to each segment and a maximum number of defective segments allowed before corrective action (Warranty Work) is required.

Definitions:

Cracking: A visible fissure or surface discontinuity that may or may not extend through the entire slab; singular or in multiple patterns. Crack types are:

Transverse: Cracks that are predominantly perpendicular to the pavement centerline

Longitudinal: Cracks that are predominantly parallel to the pavement centerline

D-Cracking: A portion of the panel separated by a crack that intersects the adjacent transverse and longitudinal joints, describing approximately a 45-degree angle with the direction of traffic, and with the length of the sides ranging from 1 foot to ½ the width of the panel on each side of the corner

Map: A series of cracks that extend only into the upper surface of the slab; for larger cracks, frequently oriented in the longitudinal direction of the pavement and interconnected by finer transverse or random cracks

Shrinkage: Partial-depth drying and plastic shrinkage cracks resulting from tensile stresses

Joint Spalling: Cracking, breaking, chipping, or fraying of the panel edges within 2 feet of the transverse or longitudinal joint

Joint Sealant Damage: Any condition that enables incompressible materials or a significant amount of water to infiltrate the joint from the surface; typically, extrusion, hardening, adhesive failure (debonding), cohesive failure (splitting), and complete loss of sealant

Shattered Slab: A pavement slab broken into four or more sections by full-depth cracks

Scaling: Deterioration of the upper concrete slab surface, normally from 0.125 to 0.5 inch in extent, and occurring anywhere on the pavement

Popout: A small piece of pavement greater than ¼ inch in diameter that has broken loose from the surface

Nonfunctioning Joints: Transverse panel joints with misaligned dowel bars or dowel bars that do not function as designed

Threshold Limits. Table 3-3 lists the allowable threshold limit for each condition parameter within each segment. If any threshold limit is exceeded, corrective action (Warranty Work) will be required. The defective segments for surface distress do not have to be contiguous to necessitate corrective action. Each driving lane, shoulder, and ramp must be evaluated independently. Any pavement surface requiring removal or replacement to correct deficiencies for any condition parameter must be placed full-width across the driving lane, shoulder, or ramp.

Corrective Actions. Table 3-3 suggests corrective actions to illustrate acceptable treatments for the various condition parameters. The Mobility Authority will accept the listed corrective action if the action addresses the cause of the distress. The DB Contractor may implement the Mobility Authority suggested corrective action or an alternative, subject to Mobility Authority approval.

Table 3-3: Threshold Limit & Corrective Action – New or Reconstructed Concrete Pavement

Condition Parameter	Segment Threshold Limits	Severity Levels ¹	Recommended Action
<u>Cracking:</u>			
Transverse	Each Affected Slab	Low Medium High	None Full Slab Replacement Full Slab Replacement
Longitudinal	Each Affected Slab	Low Medium High	None Full Slab Replacement Full Slab Replacement
D-crack	Each Affected Slab	Low Medium High	None Full Slab Replacement Full Slab Replacement
Map	>10 square feet total per slab*	N/A	Full Slab Replacement
Shrinkage	Each Affected Slab	N/A	Full Slab Replacement
<u>Joint Deficiencies:</u>			
Joint Spalling	Each Affected Joint	Low Medium High	None Partial Depth Repair Replace Joint (3 feet either side)
Joint Sealant Damage	Each Affected Joint	N/A	Replace Affected Joint Sealant
<u>Surface Defects:</u>			
Shattered Slab	Each Affected Slab	N/A	Full Slab Replacement
Popouts	>10 occurrence per slab*	N/A	Full Slab Replacement
Scaling	>10 square feet total per Slab *	N/A	Full Slab Replacement
Nonfunctioning Joints	Each Affected Joint	N/A	Replace Joint (3 feet each side)

¹ The DB Contractor shall refer to SHRP “Distress Identification Manual for the Long-Term Pavement Performance Project (SHRP-P-338) for definition of distress severity levels and measurement procedures.

*Slab is defined as: for jointed pavement, the pavement length between joints and one lane in width; for continuously reinforced pavement, a 100-foot length of pavement one lane in width. When occurrences/areas exceed the values in this table the entire length of the slab shall be replaced. When occurrences/areas are less than these values, spot repairs shall be performed (full depth for map cracking; partial depth for popouts and scaling).

3.4.3 Structural Concrete

Application. This Technical Provision 3 applies to structural concrete, including walls and barriers, water quality basin walls and structures, and concrete paving associated with bridge construction.

Limits of Warranted Work. The warranted Work shall include concrete bridge rail, bridge approach slabs, bridge deck paving, bridge superstructures, and other structural systems, including sound and retaining walls.

Condition Parameters. Condition parameters are used to measure the performance of the concrete during the Warranty term. The following condition parameters apply.

Definitions:

Through-Deck Cracking: Full-depth cracks in concrete bridge decks, typically represented by efflorescence on the bottom of the deck

Delamination: An area in the concrete where cracks have propagated from the reinforcement layers toward the concrete surface, typically due to corrosion of the reinforcement; determinable by sounding, chain drags, or other nondestructive testing methods

Spalling: Areas of concrete where cracks have progressed to cause areas of the concrete to come loose from the element

Scaling: Deterioration of the upper concrete slab surface, normally 0.125 to 0.5 inch, occurring anywhere on the deck

Popout: A small piece of the deck greater than 0.25 inch in diameter that has broken loose from the surface

Surface Finish Defects: Defects in the special surface finishes or architectural color systems, including peeling, discoloration, and staining (including any changes to the appearance of the concrete surface that do not match the specified colors of the surface treatment)

Joint Sealant Damage: Any condition that enables incompressible materials or a significant amount of water to infiltrate the joint from the surface; typically, extrusion, hardening, adhesive failure (debonding), cohesive failure (splitting), and complete loss of sealant

Threshold Limits. Table 3-4 lists the allowable threshold limit for each condition parameter. If any threshold limit is exceeded, corrective action (Warranty Work) is required.

Corrective Actions. Table 3-4 suggests corrective actions to illustrate acceptable treatments for the various condition parameters. The Mobility Authority will accept the listed corrective action if the action addresses the cause of the distress. The DB Contractor may implement the Mobility Authority suggested corrective action or an alternative, subject to Mobility Authority approval.

Table 3-4: Threshold Limit & Corrective Action - Structural Concrete

Condition Parameter	Threshold Limits	Recommended Action
Through-Deck Cracking	Any occurrence	Inject epoxy ¹
Delaminations and Spalling	Any occurrence	See Note 1 below
Scaling	Any occurrence	See Note 1 below
Popouts	5 per square yard	See Note 1 below
Surface Finish Defects	Any occurrence	See Note 1 below
Joint Sealant Damage	None allowed	Replace joint sealant

¹. The DB Contractor shall work in conjunction with the Mobility Authority to determine appropriate repair. The Mobility Authority will be the final authority on determination of the necessity for corrective action Work and acceptable treatments with respect to the listed condition parameters.

3.4.4 Steel Paint Systems

Application. This *Technical Provision 3* applies to all steel paint systems used on ornamental metal railings and structural steel members.

Limits of Warranted Work. The warranted Work shall include all structural members and steel ornamental railing.

Condition Parameters. Condition parameters are used to measure the performance of the paint systems during the Warranty term. The following condition parameters apply.

Definitions:

Visible Rust or Rust Breakthrough: Any corrosion of the steel member

Paint Blistering: Areas in the paint system where the paint has bubbled or loosened from the steel member

Peeling and Scaling: Areas in the paint system where the paint is no longer adhering to the steel member, causing loss of paint system

Chalking: White or gray surface imperfection, apparent from discoloration of surface

Threshold Limits. Table 3-5 lists the allowable threshold limit for each condition parameter. If any threshold limit is exceeded, corrective action (Warranty Work) is required.

Corrective Actions. Table 3-5 suggests corrective actions to illustrate acceptable treatments for the various condition parameters. The Mobility Authority will accept the listed corrective action if the action addresses the cause of the distress. The DB Contractor may implement the Mobility Authority suggested corrective action or an alternative, subject to Mobility Authority approval.

Table 3-5: Threshold Limit & Corrective Action – Steel Paint Systems

Condition Parameter	Threshold Limits	Recommended Action
Visible Rust or Rust Breakthrough, Paint Blistering, Peeling, Scaling, or Chalking	Any occurrence	Repair to meet painting specifications. Obtain approval of all repair procedures by the RE. ¹

¹ The DB Contractor shall work in conjunction with the Mobility Authority to determine appropriate repair. The Mobility Authority will be the final authority on determination of the necessity for corrective action Work and acceptable treatments with respect to the listed condition parameters.

3.4.5 Concrete Sealer Systems

Application. This *Technical Provision 3.4.5* applies to all pigmented and clear stains and sealers used on ornamental concrete walls and structural concrete members.

Limits of Warranted Work. The warranted Work shall include all structural concrete members and ornamental concrete walls.

Condition Parameters. Condition parameters are used to measure the performance of the stain and sealer systems during the Warranty term. The following condition parameters apply.

Definitions:

Visible Rust or Staining: Any corrosion of the underlying structural members that result in rust or staining on the concrete surface.

Sealer Blistering: Areas in the concrete sealer system where the sealer has bubbled or loosened from the steel member

Peeling and Scaling: Areas in the sealer system where the sealer is no longer adhering to the concrete member, causing loss of sealer system

Chalking: White or gray surface imperfection, apparent from discoloration of surface

Threshold Limits. Table 3-6 lists the allowable threshold limit for each condition parameter. If any threshold limit is exceeded, corrective action (Warranty Work) is required.

Corrective Actions. Table 3-6 suggests corrective actions to illustrate acceptable treatments for the various condition parameters. The Mobility Authority will accept the listed corrective action if the action addresses the cause of the distress. The DB Contractor may implement the Mobility Authority suggested corrective action or an alternative, subject to Mobility Authority approval.

Table 3-6: Threshold Limit & Corrective Action - Concrete Sealer Systems

Condition Parameter	Threshold Limits	Recommended Action
Visible Rust or Staining, Sealer Blistering, Peeling, Scaling, or Chalking	Any occurrence	Repair to meet concrete sealer specifications. Obtain approval of all repair procedures by the RE. ¹

¹ The DB Contractor shall work in conjunction with the Mobility Authority to determine appropriate repair. The Mobility Authority will be the final authority on determination of the necessity for corrective action work and acceptable treatments with respect to the listed condition parameters.

3.4.6 Differential Settlement of New Roadway Grade (Including Bridge Fills)

Application. This Technical Provision 3 applies to settlement Warranties on all new roadway and ramp subgrades constructed within the Project limits.

Limits of Warranted Work. The warranted Work shall include all subgrade excavation, embankment, and aggregate base placed on the roadway below the pavements and in sideslope areas, including bridge approach panels and pavement over culverts and utilities.

Condition Parameter. Condition parameters are used to measure settlement in surface differential settlement in the pavement. The differential settlement will be measured (both along the roadway profile and transversely between lanes, shoulders, and adjacent structures) along 25-foot intervals using a high-

speed or lightweight inertial profiler, certified at the Texas Transportation Institute in accordance with Item 585 in the *Standard Specifications for Construction and Maintenance of Highways, Streets, and Bridges*, adopted by TxDOT in November 2014. Transverse profile shall be recorded with a 16’ straight edge with an interval of at least every 1/10 of a mile and at discrete locations where uneven pavement is apparent. Longitudinal profiles 100 feet leading into and away from bridge structures shall be recorded with a 16’ straight edge.

Threshold Limits. Table 3-7 lists the allowable threshold limit within each segment. If any threshold limit is exceeded, corrective action (Warranty Work) is required. The defective segments for surface distress do not have to be contiguous to necessitate corrective action. Any pavement surface requiring removal or replacement to correct deficiencies for any condition parameter must be placed full-width across the driving lane, shoulder, or ramps.

Corrective Actions. Table 3-7 suggests corrective action to illustrate acceptable treatment for the condition parameter. The Mobility Authority will accept the listed corrective actions. The DB Contractor may implement the Mobility Authority suggested corrective action or an alternative action, subject to Mobility Authority approval.

Table 3-7: Threshold Limit & Corrective Action - Differential Settlement of New Roadway Grade

Condition Parameter	Segment Threshold Limit	Recommended Action
Pavement Surface Differential Settlement (longitudinal measurement outside bridge areas)	IRI>95	Profile mill/ milling and overlay as necessary to maintain pavement thickness
Pavement Surface Differential Settlement (longitudinal measurement 100 feet leading into and away from bridges)	1/8-inch variation between any two contacts on a 16-foot straight edge	Profile mill/ milling, overlay and/or jacking as necessary to maintain pavement thickness
Pavement Surface Differential Settlement (transverse measurement)	1/8-inch variation between any two contacts on a 16-foot straight edge	Profile mill/ milling and overlay as necessary to maintain pavement thickness

3.4.7 Settlement and Deflection: Sound, Retaining, and Neighborhood Walls and Barriers

Application. This *Technical Provision 3* applies to all sound, retaining, and neighborhood walls and barriers designed and constructed by the DB Contractor.

Limits of Warranted Work. The warranted Work shall include all sound, retaining, and neighborhood wall and barrier materials, footings, and hardware designed and constructed by the DB Contractor and the installation procedures (including problems arising from excessive settlement).

Threshold Limits. Table 3-8 lists the allowable threshold limits for differential settlement and lateral deflection of sound, retaining, and neighborhood walls and barriers. If any threshold limit is exceeded, corrective action (Warranty Work) is required.

Table 3-8: Threshold Limit & Corrective Action - Settlement of Sound, Retaining, and Neighborhood Walls and Barriers

Condition Parameter	Threshold Limit	Recommended Action
Differential Settlement	0.5 inch in 10 feet of horizontal distance	Submit recommended design for corrective action to the Mobility Authority for approval. In lieu of corrective action, the DB Contractor may be assessed 50% of the current replacement cost of the wall.
Lateral Deflection	1.00 inch in 10 feet of vertical height	Submit recommended design for corrective action to the Mobility Authority for approval. In lieu of corrective action, the DB Contractor may be assessed 50% of the current replacement cost of the wall.

3.4.8 Signing (Permanent)

Application. This Technical Provision 3 applies to all permanent signing installed by the DB Contractor.

Limits of Warranted Work. The warranted Work shall include all permanent signing materials, hardware, and overhead sign structures installed by the DB Contractor. Signs damaged by forces beyond the control of the DB Contractor, such as maintenance activities, accidents, or acts of nature, will relieve the DB Contractor of any further Warranty related to the damaged portion of the sign device.

Warranty Requirements. The DB Contractor must repair or replace any material or equipment that fails to perform or meet the Project signing standards and/or specifications.

3.4.9 Traffic Signals

Application. This Technical Provision 3 applies to all traffic signals installed by the DB Contractor.

Limits of Warranted Work. The warranted Work shall include all material, equipment, and installation of traffic signals by the DB Contractor.

Warranty Requirements. The DB Contractor must repair or replace any material or equipment that fails to perform or meet the Project traffic signal standards and/or specifications.

3.4.10 Turf and Landscape/Tree Establishment

Application. This Technical Provision 3 applies to turf establishment on all disturbed areas within the Project limits and landscape and tree establishment as shown in the Exhibit C – Attachment 10-1 183 North Mobility Project Aesthetic Design Guide.

Limits of Warranted Work. The warranted Work shall include all plant materials and seeding, fertilizing, irrigation, and mulching necessary to establish turf and landscape and trees within the Project limits.

Condition Parameter. Condition parameters are used to measure the performance of the turf and landscape/tree establishment.

Threshold Limits. Table 3-9 lists the allowable threshold limits for grass establishment and tree and shrub establishment. If any threshold limit is exceeded, corrective action (Warranty Work) is required.

Corrective Actions. Table 3-9 specifies corrective action to illustrate acceptable treatments for the condition parameter. The Mobility Authority will accept the listed corrective actions. The DB Contractor may implement the Mobility Authority suggested corrective action or an alternative action, subject to Mobility Authority approval. Once the inspected areas have been reestablished by the DB Contractor, the Mobility Authority will notify the DB Contractor that the terms of the Warranty period have been met and that the Warranty period is complete.

Table 3-9 Threshold Limit & Corrective Action - Plant Coverage for Erosion Control in Seeded Areas

Condition Parameter	Threshold Limit	Recommended Action
Turf Establishment Landscape/Tree Establishment	<ul style="list-style-type: none"> • 2-inch high grass growth • >5% of seed areas is bare ground • Any area >100 square feet is bare ground • Single trunk trees shall have a straight leader with less than 1 degree deviation from parallel from the top of the rootball to the crown of the tree. • Trees and shrubs shall have full, healthy leaf cover on all branches. • Deciduous trees and shrubs that are in a point of dormancy shall have their warranty extended until leaves are out and can be evaluated. • Trees and shrubs shall be symmetrically balanced in form. 	Repair and reseed to meet Turf (Grasses) and Landscaping/Tree Establishment specifications. Obtain approval of all repair procedures by the Mobility Authority. ¹

¹ The DB Contractor shall work in conjunction with the Mobility Authority to determine appropriate repair. The Mobility Authority will be the final authority on determination of the necessity for corrective action work and acceptable treatments with respect to the listed condition parameters.

3.4.11 Lighting

Application. This *Technical Provision 3* applies to all new lighting within the Project limits and to existing lighting relocated by the DB Contractor.

Limits of Warranted Work. The warranted Work shall include all material (including replacement of light bulbs), equipment, and installation of the lighting for this Project.

Warranty Requirements. The DB Contractor must repair or replace any lighting material or equipment that fails to perform or meet the Project lighting standards and/or specifications.

3.4.12 Utilities

Application. This Technical Provision 3 applies to Warranties on all the DB Contractor directed utility relocations within the Project limits.

Limits of Warranted Work. The warranted Work shall include all material and workmanship associated with the DB Contractor managed utility relocations for this Project.

Warranty Requirements. The DB Contractor must perform video camera inspections before the Final Acceptance to verify that materials and workmanship comply with specifications.

3.4.13 Buildings, Toll Facilities, and Related Facilities

Application. This Technical Provision 3 applies to Warranties on all DB Contractor directed buildings, toll facilities and related facilities.

Limits of Warranted Work. The warranted Work shall include all material and workmanship associated with the DB Contractor directed buildings, toll facilities and related facilities.

Warranty Requirements. The DB Contractor must repair or replace any material or equipment that fails to perform or meet the Project standards and/or specifications.

3.4.14 Pavement Markings and Flexible Delineators

Application. This Technical Provision 3 applies to Warranties on all new pavement markings and flexible delineators installed by the DB Contractor.

Limits of Warranted Work. The warranted Work shall include all material, equipment, and installation of pavement markings and flexible delineators by the DB Contractor. Flexible delineators damaged by forces beyond the control of the DB Contractor, such as maintenance activities, accidents, or acts of nature, will relieve the DB Contractor of any further Warranty related to the damaged portion of the delineator.

Warranty Requirements. The DB Contractor must repair or replace any material or equipment that fails to perform or meet the Project pavement marking and flexible delineator standards and/or specifications including color, retroreflectivity, or durability performance requirements.

3.5 Failure Adjustments Terms

In the event of a failure on any items contained in this Technical Provision 3, the Warranty term for the failed element shall be modified as follows:

- For all items covered by an original Warranty period of 1 year, the original Warranty term shall be extended by a term of 6 months

- For all items covered by an original Warranty period of 2 years or more, the original Warranty term shall be extended by a term of 12 months.

3.6 Submittals

Table 3-10: Submittals to Mobility Authority

Submittals	Submittal Schedule	Mobility Authority Action	Reference Section
Warranty Work Plan	10 Business Days before starting Warranty Work	Review	3.3.4

4.0 COMMUNITY RELATIONS PROGRAM

4.1 Introduction

Purpose. The Mobility Authority seeks an effective and proactive approach to Community Relations that informs and engages the public throughout the design and construction of the Project. The objective of the Community Relations Program (CRP) is to maintain a high level of communication by informing and engaging local Governmental Entities, special interest groups, businesses, communities, and the general public about the Project status throughout the design and construction period. The Mobility Authority will be responsible for developing the Community Relations Program; however, the DB Contractor will coordinate and collaborate with the Mobility Authority on a Community Relations Program Plan (CRP Plan) and will be responsible for communicating with, and providing information as described in this *Technical Provision 4* to, in a timely manner, the Mobility Authority and TxDOT. The Project Management Plan (PMP) shall include processes for keeping the Mobility Authority and TxDOT informed about construction activities. The DB Contractor shall be responsible for supporting the Community Relations Program in accordance with the requirements identified in this *Technical Provision 4*.

4.2 Community Relations Program (CRP)

Plan. The implementation of a robust CRP is vital to the overall success of the Project. The DB Contractor shall collaborate with the Mobility Authority on implementing the CRP Plan developed by the Mobility Authority. The DB Contractor shall attend a communications planning workshop within 15 days after NTP 1 to discuss and agree on the content of the CRP Plan.

The Mobility Authority will organize and implement the workshop to include the Mobility Authority's Project Manager, Director of External Affairs, and communications staff, representatives from the City of Austin and TxDOT. The DB Contractor's Project Manager and Construction Manager shall be required to attend. Each of these entities will have a role in Project communications; the workshop shall clarify and document those roles.

The DB Contractor shall collaborate with Mobility Authority staff in implementing the CRP for the Project by providing Mobility Authority staff the required information as a means to:

- Inform the public on status of design and construction.
- Provide the public with an opportunity for input.
- Notify the public in advance of construction, traffic detours, and potential impacts.

As part of the CRP, the DB Contractor and the Mobility Authority will assist with finalizing the CRP Plan developed by the Mobility Authority. The CRP Plan will include strategies and tactics, specific timelines and deliverables. The CRP Plan shall specifically address:

- A detailed work plan with an allocation of responsibilities by party.
- Air, lighting, and noise quality measures methodology.
- Traffic management and construction staging methodology.
- Interaction to address community, federal, state and local agencies.
- Summarize key issues anticipated to be addressed through the life of the Project.
- Construction or design related adjustments in response to community concerns.
- Emergency response plan.

Mobility Authority Review. Prior to finalizing the CRP Plan, any construction activity shall require approval by the Mobility Authority.

4.3 Staffing Requirements

The DB Contractor shall provide information and support staff, including a dedicated Community Relations Specialist (CRS), as requested by the Mobility Authority to implement the CRP Plan including preparation of all materials and attendance at meetings and presentations. All community outreach regarding project status and construction impacts shall be performed under the direction of or by a CRS.

The DB Contractor shall staff a telephone hotline answered 24 hours a day, 7 days a week.

Responsibilities. The DB Contractor shall assist in community relations activities related to the Project, including (but not limited to) the following:

- Assistance in the emergency response program.
- Attendance by the CRS and Construction Manager at a weekly PI meeting with the Mobility Authority starting at NTP 1 and continuing through Final Acceptance.
- Providing updates for the Mobility Authority's Project internet website.
- Cooperation with local and regional government agencies as directed by the Mobility Authority.
- Staffing of public meetings with individuals who can provide technical subject matter expertise to Mobility Authority staff and public meeting attendees who may have questions or comments.
- Preparation and distribution of regular updated materials to those identified by the Mobility Authority.
- Supporting meetings and events involving community groups.
- Staffing a bi-lingual (English and Spanish) telephone hotline to respond to public inquiries, information requests, and complaints about the Project as per *Technical Provision 4.6*. Maintaining a log of all inquiries and responses.

- Preparation and distribution of project information and statistics such as employment data, green initiative results, and construction progress. Employment data to be reported monthly to include total number of employees and full time equivalents working on the Project for each contractor, subcontractor, provider, and consultant.

News Media. Any and all contact with the news media by the DB Contractor’s team shall be coordinated through the Mobility Authority.

CRS Qualifications. Unless otherwise approved by the Mobility Authority, the CRS shall have the following minimum qualifications:

- Bachelor's Degree in Communications, Marketing, Public Relations, Political Science, Planning, or related field.
- Five years of experience in community relations, construction communications, public involvement, marketing and/or public relations on behalf of public agencies or other clients.
- The ability to work well with the public and interact effectively with all organizational levels, including agency staff, senior management, executive leadership, board members, community leaders, and city/county/state representatives.
- Knowledge and experience with social media platforms, e-mail marketing, event planning, and development of public outreach materials.
- The ability to demonstrate familiarity with community outreach tactics for similar projects.
- The Mobility Authority shall have the authority to approve the CRS replacement if the CRS is not performing their duties adequately.

CRS Duties. Primary duties are to:

- Ensure the public is informed on the status of project design and construction, including traffic detours and other impacts, as defined in the Community Relations Plan.
- Manage and oversee community outreach efforts on construction impacts acting as a liaison between technical project team members and the public.
- Attend external project, agency, and community meetings to provide project updates and prepare documentation of meetings.

4.4 Project Website/Social Media

The DB Contractor shall be required to provide information for the Project website as identified in this Technical Provision 4. Information shall be updated as necessary or requested by the Mobility Authority.

In addition to information for the website, the DB Contractor shall also provide information for social media updates, e-mail blasts and text message alerts used to keep the public informed.

Website Development and Maintenance. Within 20 Business Days following issuance of NTP 1, the DB Contractor shall provide available pertinent Project information to the Mobility Authority for posting onto a Project website that will be maintained by the Mobility Authority. Pertinent Project information to be provided by the DB Contractor shall include but is not limited to:

- Schematic Maps.
- DB Contractor Contact Information.
- Road closures and traffic control information (to be posted no less than 72 hours prior to closure. Major closures shall adhere to the notification requirements of *Technical Provision 4.6*).
- Project Fact Sheet.
- Project Schedule.
- Contact information for employment.
- Contact information for DBE opportunities.

During the contract period the DB Contractor will continue to provide information and content for the website to ensure information remains current and relevant to users. The requirements established for the Project website are in addition to websites discussed in *Technical Provision 1*.

Website Comments/Response: The DB Contractor will be responsible for providing the information necessary for the Mobility Authority to respond to comments and inquires in a timely manner. Information for routine web site inquiries shall be provided within 1 Business Day. When a complaint is received regarding an immediate/ongoing concern, the DB Contractor will have 1 hour after receiving the complaint to provide the Mobility Authority with information necessary to respond in a timely manner. In addition, the DB Contractor will be responsible for making sure that any follow up information or materials requested by the Mobility Authority are provided in a timely fashion.

4.5 Special Events and Activities

The DB Contractor shall be required to participate in all special events and activities as described in this *Technical Provision 4.5*.

The Mobility Authority wants to provide multiple opportunities for the public to be engaged in the Project in fun and informative settings including but not limited to:

Groundbreaking Ceremony: The DB Contractor shall participate in a groundbreaking ceremony to mark the beginning of the construction of the Project. The DB Contractor shall provide for the following elements for the groundbreaking: tents, chairs, stage, podium, sound system, site preparation, mementos, refreshments, invitations, and program, as requested by the Mobility Authority. The DB Contractor will

work with the Mobility Authority to identify the location of the ceremony, assist with parking, set up and tear down, logistics, and traffic control for the ceremony as directed by the Mobility Authority.

Community Events: The DB Contractor will be required to coordinate and support a minimum of 50 community events (such as Meet the Contractor, kids' day or neighborhood barbecue) during the life of the Project as directed by the Mobility Authority, from NTP 1 through Final Acceptance, aimed at providing communities with opportunities to learn firsthand about the Project and to thank nearby residents and businesses for their patience during the construction process. These events targeting the local community can include elements such as: construction safety presentations; information on the project; hands on equipment demonstrations; giveaways; food and refreshments. The DB Contractor will be responsible for providing all of the construction equipment, personnel, and materials and information about the Project, as directed by the Mobility Authority.

Media Events: The DB Contractor will be required to support a minimum of 3 media events (such as first drive or technology demonstrations) during the life of the Project, from NTP 1 through Final Acceptance, aimed at providing promotional and educational opportunities during the construction process. These events targeting the local and regional media can include elements such as: live technology demonstrations; hands on equipment demonstrations; information on the project; live interviews; food and refreshments. The DB contractor will be responsible for providing all of the construction equipment, personnel, and materials and information about the Project, as directed by the Mobility Authority.

Grand Opening Ceremony: The DB Contractor will be required to participate in a grand opening ceremony to mark the opening of the Project. The DB Contractor shall plan and coordinate the grand opening ceremony in coordination with the Mobility Authority. The DB Contractor shall provide the following elements for the grand opening: tents, chairs, stage, podium, sound system, site preparation, mementos, refreshments, invitations, and program, as directed by the Mobility Authority. The DB Contractor shall work with the Mobility Authority to identify the location of the ceremony, assist with parking, set up and tear down, logistics, and traffic control for the grand opening ceremony as directed by the Mobility Authority. The Mobility Authority will create a theme and determine the attendees, program, and speakers for the event and will handle execution of the ceremony.

4.6 Community/Business Outreach

The DB Contractor shall be required to participate in all community/business outreach as described in this *Technical Provision 4.6.*

The DB Contractor will be required to support the Mobility Authority in implementation of outreach activities that will strengthen understanding of the Project. The Mobility Authority envisions a community outreach program that supports the Project and includes, but is not limited to:

Neighborhood Meetings, Community Meetings, and Stakeholder Briefings: The DB Contractor and the Mobility Authority will work together to arrange for and make presentations to various groups about the

Project. The DB Contractor shall provide information to the Mobility Authority to the extent necessary to inform the community about the project. These meetings will be attended by appropriate DB Contractor team representatives who are capable of addressing technical questions related to the Project. As needed, the DB Contractor shall provide for additional appropriate staffing. The DB Contractor shall provide key design or construction personnel, and oral, written, and graphic information, including (but not limited to) the following items:

- The design and location of local streets and utilities impacts.
- The design and implementation of street and roadway detours.
- Scheduling and hours of construction activities.
- Truck haul routes.
- Methods to minimize noise and dust.
- Turf establishment and environmental mitigation measures.
- Any other relevant topics requested by the Mobility Authority, the local municipalities within the Project corridor, landowners, or community groups.

Project Tours: The Mobility Authority will arrange and provide Project site tours with interested groups and individuals such as community groups, conference groups, elected officials, business representatives, media, and others throughout the life of the Project. The DB Contractor will be required to accommodate Project site tours and to provide DB Contractor team representatives as directed by the Mobility Authority for Project site tours.

Hotline: The DB Contractor shall be responsible for setting up and staffing a 24-hour bi-lingual (English and Spanish) hotline throughout the life of the Project. The hotline shall include both a 1-800 number with an easy to remember name plus a local number. It shall be answered by a person. For this Project, a voice mail system will not be allowed. The DB Contractor shall respond to all routine hotline phone calls within 1 Business Day. Calls regarding an ongoing problem that warrants immediate resolution shall be responded to within 2 hours. All calls shall be documented in a call log to include time of call, callers name and contact information, subject of the call, to whom it was routed, the time of the response and the response to the caller. Call logs shall be updated weekly and provided to the Mobility Authority on a monthly basis to coincide with the DB Contractor's Draw Requests.

Website Comments/Response: The DB Contractor will be responsible for providing the information necessary for the Mobility Authority to respond to comments and inquiries in a timely manner. Information for routine website inquiries shall be provided within 1 Business Day.

Community Involvement: As a good corporate citizen, the DB Contractor will participate in or sponsor community events and activities that take place within or adjacent to the Project corridor.

Presentations to Business Groups: The Mobility Authority will identify business groups and large employers and arrange presentations on the Project. These meetings will be attended by appropriate DB Contractor team representatives who are capable of addressing technical questions related to the Project. The DB Contractor will be required to prepare presentation and meeting materials for presentations to business groups as directed by the Mobility Authority.

Business Impact Mitigation Activities: The DB Contractor will support the Mobility Authority with impacted business and property owners to mitigate construction activities. The DB Contractor should plan to participate in a plan developed by the Mobility Authority to help promote impacted businesses during construction. The plan will identify innovative ways to maintain activity to businesses during construction. Such concepts may include, but not be limited to, enhanced directional signage, special events, advertising and coupon distribution.

Traffic Impacts/Road Closures Notices: The DB Contractor will be responsible for preparing traffic impact and road closure notifications for the website and/or local media. Community Relations team, as defined in the CRP plan, shall be informed of impacts at least two weeks in advance, or as soon as they are confirmed, to prepare for communication of impacts. Notices announcing impacts will be posted to the website at least 72 hours in advance, and, as deemed necessary, provided to the Mobility Authority to be distributed to the media in a format that includes a map clearly identifying the roads impacted, closures and detour routes. In addition to those identified in the DB Contractor's MOT plan, the DB Contractor shall be responsible for providing and placing portable messaging signs (up to four) as requested. Messaging on the signs will be current and accurate at all times.

See *Technical Provision 22* for more details on timeframes for providing lane closure notices to the Mobility Authority for approval and emergency situation response.

Project Related Media Releases: The DB Contractor will support the Mobility Authority communications staff in the development of project related media releases to announce newsworthy Project milestones or events. The DB Contractor will provide background and technical information, photos and interview sources to the Mobility Authority. The Mobility Authority is responsible for the dissemination of all media releases.

4.7 Briefings, Meetings, and Coordination

The DB Contractor shall be required to participate in briefings, meetings, and coordination as described in this *Technical Provision 4*.

Quarterly Reports. The DB Contractor shall provide the Mobility Authority with Project status updates quarterly for presentations at Mobility Authority Board of Director's Meetings. These updates will be provided at the Project status meetings. As requested by the Mobility Authority, the DB Contractor shall attend monthly Mobility Authority Board of Directors Meetings.

Meeting Minutes. For all community relations briefings and meetings at which the DB Contractor is in attendance, the DB Contractor shall, within 2 Business Days of the meeting, submit a draft of the meeting minutes to the Mobility Authority for review. After receipt of the Mobility Authority's approval or comments, the DB Contractor shall incorporate any comments and resubmit to the Mobility Authority the final minutes within 2 Business Days. Draft minutes may be submitted electronically; however, the final Mobility Authority approved minutes shall be submitted as a final electronic file copy. The Mobility Authority shall be responsible for the distribution of final Mobility Authority approved meeting minutes to appropriate parties.

Content of Minutes. At a minimum, all briefing or meeting minutes shall contain:

- A complete list of attendees (including their affiliations, e-mail addresses, and telephone numbers).
- Descriptions of issues discussed.
- Decisions made and direction given.
- Remaining open issues and action items (including identification of the party responsible for follow-up and the target date for resolution).

4.8 Emergency Response Activities

If an emergency occurs that affects the safety or protection of persons, the Project, or the property at the site or adjacent thereto, the DB Contractor shall immediately act to prevent and mitigate the threatened damage, injury, or loss. The DB Contractor shall cooperate with law enforcement and other emergency response agencies, especially in addressing concerns about access of emergency providers, and communicate regularly with them via notifications and meetings, as specified in detail in Technical Provision 22.

An Emergency Response Plan will be developed as part of the CRP Plan. The DB Contractor will be responsible for complying with the plan and supporting the Mobility Authority, if implementation of plan elements becomes necessary.

4.9 Submittals

Table 4-1: Submittals to Mobility Authority

Submittals	Submittal Schedule	Mobility Authority Action	Reference Section
Project information for posting onto a Project website	Within 20 Business Days following issuance of NTP 1	Information	4.4
Draft Meeting Minutes	Within 2 Business Days	Review and Comments	4.7
Final Meeting Minutes	Within 2 Business Days	Approval	4.7

5.0 PROJECT SCHEDULE

5.1 General Requirements

The Project Schedule shall define the timeframe for completion of the Project and achievement of milestones, and be used to monitor progress and denote changes that occur during design and construction as well as serving to determine the amount due to the DB Contractor for a progress payment. Before the commencement of any Schedule Activity, the DB Contractor shall submit a Project Baseline Schedule (PBS) in accordance with the Work Breakdown Structure based upon the preliminary PBS-1 submitted with the Proposal.

The scheduling software employed by the DB Contractor shall be compatible with the current and any future scheduling software employed by the Mobility Authority (currently Primavera 8.3). Compatible shall mean that DB Contractor-provided electronic file version of a schedule may be loaded or imported by the Mobility Authority using the Mobility Authority's scheduling software with no modifications, preparation, or adjustments to do so.

The DB Contractor shall manage and execute the Work using the PBS.

All Project Schedules shall comply with the following:

- Include all Schedule Activities.
- Identify all planned dates for start and completion of construction related to any Schedule Activity.
- Tie all phases of Work together logically to present a total Critical Path Method (CPM) schedule in one electronic file.
- Include the milestone schedule deadlines.
- Cost load all Payment Activities.
- Cost load any Schedule Activities that are required to provide aggregate cost for associated Payment Activities.
- The cost and description of any aesthetic treatment incorporated in the Construction Work shall be separately identified for each Payment Activity.
- Ensure the cost loaded activities are at a level of detail that allows assigned quantities to be commodity specific for consistent complete Work.
- Identify Schedule Activities with a Float of less than 10 days as critical Schedule Activities.

- Constrain only the Schedule Activities that represent any milestone schedule deadlines with a “start on or before” or “finish on or before” constraint.
- Include the components as described below:
 - Activity Identification - The DB Contractor shall use unique and consistent activity identification numbers, textual descriptions and codes in all Project Schedule Submittals. Each Schedule Activity shall have a detailed, concise description of the Work represented by the activity title. Descriptions will indicate definable items of Work typically starting with a verb. The activity identification numbers relating to a specific activity title or description shall remain unchanged and connected to the original activity title or description throughout the duration of the Work. Payment Activity identification numbering should contain one or more characters that uniquely identify them as Payment Activities. A Schedule Activity’s description may only be changed to clarify a Schedule Activity’s scope. The scope or purpose of a Schedule Activity shall not be changed except through a Change Order.
 - Early and Late Dates - Early Dates shall be based on proceeding with the Work as early as allowed in the Contract Documents. Late dates shall be based on completing the Work required for each service commencement. The early start dates of the project schedule are the earliest that any activity in the schedule can be scheduled to start given the logic and constraints of the schedule. The early finish of an activity in the schedule is the earliest that the activity can be scheduled to be completed given the logic and constraints of the schedule. The late start of an activity is the latest that a project activity can be scheduled to be started without having to reschedule the calculated early finish of the project. The late finish of an activity is the latest that a project activity can be finished without having to reschedule the late finish of the project. The late finish of the project is the late finish of the last activity to be completed in the project.

All schedules must be displayed per the following:

- Schedule Activities shall be shown on their early dates.
- The Critical Path shall be highlighted in red on all schedules to distinguish critical Schedule Activities from other Schedule Activities and Float shown for all Schedule Activities.
- The Project shall be organized consistent with the Work Breakdown Structure (WBS). Each Schedule Activity shall be mapped to one and only one of the WBS elements.
- The Project title and data date shall be displayed on all schedules, charts, and diagrams. A legend shall be provided on all schedules, charts, and diagrams, which indicates the various symbols used and their meaning.

5.2 Project Baseline Schedule

5.2.1 General

The DB Contractor shall use the Preliminary Project Baseline Schedule (PBS-1) submitted with the Proposal as a foundation to prepare Project Baseline Schedule 2 (PBS-2) and shall submit PBS-2 to the Mobility Authority for review and acceptance.

PBS-2 shall reflect the DB Contractor's intended execution plan for the Work including all final design elements to date, and final quantity assessments for each scheduled construction activity.

The data date for PBS-2 shall be the date of NTP1. The DB Contractor shall receive the Mobility Authority's acceptance of the PBS-2 prior to issuance of NTP 2 and prior to submitting the first Draw Request for payment of any NTP 2 Work.

The accepted PBS-2 shall be progressed, updated, and submitted monthly as Project Status Schedule Updates until PBS-3 is accepted. PBS-3 shall be submitted within 90 days of NTP 2. The accepted PBS-3 shall remain in force until such time as a Revised PBS is submitted to, and accepted by, the Mobility Authority, if applicable, which shall then become that latest accepted PBS (ie, PBS-4). The Mobility Authority will confirm in writing the acceptance of each PBS and Revised PBS. Subsequent revisions to PBS-3 shall be numbered sequentially as follows, PBS-4, PBS-5, etc..

The Mobility Authority will review the PBS or Revised PBS within 21 days of submission. In the event that the Mobility Authority does not accept the PBS, the DB Contractor shall revise and resubmit it with changes clearly identified. The Mobility Authority will review each resubmission of the PBS within 21 days of resubmission.

The DB Contractor shall define a complete and logical plan in the PBS that can realistically be accomplished for executing the Work. The PBS shall:

- Reflect the proposed approach to accomplish the Work.
- Include all major activities of Work required by the Contract Documents and also include activities for property acquisitions, Utility Adjustments, Utility Betterments, permit acquisitions, and interfaces with other projects and Governmental Entities including interfaces with the System Integrator in toll zones. The DB Contractor shall set up a distinct WBS for any Betterment.
- Indicate the sequence of performing each major activity and the logical dependencies and interrelationships among the activities and shall provide a sufficient number of activities to assure adequate planning to allow monitoring and evaluation of progress and, if applicable, payments.

- Include a listing of all submittals and submittal activity durations including specific durations for the Mobility Authority review and/or acceptance of the DB Contractor’s submittals.

The DB Contractor is solely responsible for planning and executing the Work and the Mobility Authority’s acceptance of a PBS does not:

- Imply approval of any construction methods or relieve the DB Contractor’s responsibility to provide sufficient materials, equipment, and labor to guarantee completion of the Project in accordance with the Contract Documents.
- Attest to the validity of assumptions, activities, relationships, sequences or any other aspect of the PBS.

Failure by the DB Contractor to include any element of the Work required by the Contract Documents in the accepted PBS does not relieve the DB Contractor of the responsibility to perform such Work.

5.2.2 Work Breakdown Structure

The DB Contractor shall develop PBS-2 in accordance with the Work Breakdown Structure (WBS), the minimum requirements of which are included in *Exhibit C – Attachment 5-1 – WBS Minimum Requirements* of the *Technical Provisions*, Work Breakdown Structure Requirements, which is resource and cost loaded in accordance with **Table 5-1**, to the Mobility Authority for review and acceptance. Each Schedule Activity shall be mapped to one of the WBS levels. Each segment of the Work shall be to the same level of detail. The DB Contractor shall utilize the organizational structure of **Table 5-1**, the minimum requirements of which are included in *Exhibit C – Attachment 5-2 – Organizational Structure for Cost Reporting* of the *Technical Provisions*.

The PBS shall be organized consistent with the WBS. The DB Contractor may add WBS elements and/or levels to those presented in *Exhibit C – Attachment 5-1 – WBS Minimum Requirements* with the Mobility Authority’s written approval. The DB Contractor shall further develop and detail the initial WBS in accordance with its specific Schedule Activities and retain the ability to summarize to at least the same level as shown in *Exhibit C – Attachment 5-1 – WBS Minimum Requirements* or as approved by the Mobility Authority. The DB Contractor shall assign the WBS structure consistently and uniformly among all similar activity types and shall develop the WBS with clearly identifiable linkage to the Schedule of Values and Schedule Activities.

Table 5-1: Schedule Level-of-Detail Requirements

Discipline	Detail	PBS-1	PBS-2	PBS-3+
Right-of-Way Acquisition	WBS Level	4	All Levels	All Levels
	Cost Loading	No	Yes	Yes
	Resource Loading	No	No	No
	Maximum duration of Schedule Activity	No maximum	20 Days ¹	20 Days ¹
Preconstruction	WBS Level	4	All Levels	All Levels

Discipline	Detail	PBS-1	PBS-2	PBS-3+
Submittals and Permitting	Cost Loading	No	Yes	Yes
	Resource Loading	No	No	No
	Maximum duration of Schedule Activity	No maximum	20 Days ¹	20 Days ¹
Utility Coordination	WBS Level	4	All Levels	All Levels
	Cost Loading	No	Yes	Yes
	Resource Loading	No	No	No
	Maximum duration of Schedule Activity	No maximum	20 Days ¹	20 Days ¹
Design	WBS Level	4	All Levels	All Levels
	Cost Loading	No	Yes	Yes
	Resource Loading	No	No	No
	Maximum duration of Schedule Activity	No maximum	20 Days ¹	20 Days ¹
Utility Relocation	WBS Level	5	All Levels	All Levels
	Cost Loading	No	Yes	Yes
	Resource Loading	No	No	Yes
	Maximum duration of Schedule Activity	No maximum	40 Days ¹	20 Days ¹
Construction	WBS Level	4	All Levels	All Levels
	Cost Loading	No	Yes	Yes
	Resource Loading	No	No	Yes
	Maximum duration of Schedule Activity	No maximum	40 Days ¹	20 Days ¹

¹Unless otherwise approved by the Mobility Authority.

5.2.3 Project Baseline Schedule Requirements

The DB Contractor shall cost-load the PBS-2 and PBS-3 as follows:

- Provide a sufficient number of activities so that the budget of any one activity does not exceed \$1.0 million in the schedule, unless otherwise approved by the Mobility Authority.
- Allocate the total dollar amount throughout the Payment Activities in the PBS. Such allocation shall not artificially inflate, imbalance, or front-load line items.
- The DB Contractor’s indirect costs such as project management, administration, contingencies, site cleanup and maintenance and security costs related to design-build costs shall be prorated through all Payment Activities.
- Values shall be allocated only to task-dependent Payment activities for which completion progress can be measured and tracked.
- Price should be capable of reporting at WBS Level 2.

Resources shall be incorporated into the PBS-3 in accordance with **Table 5-1** per the following requirements:

- Provide a list of crews with associated labor and equipment resources to the Mobility Authority with the schedule submittal.
- Define crews as a labor resource type and assign to appropriate activities.
- Provide the Mobility Authority with a definition, the composition of and production rate for each crew type.
- Do not include any costs for labor resources and do not calculate cost from units (price/unit = \$0.00).
- The “quantity” assigned to each activity shall represent the estimated efforts in place for the Schedule Activity value.

All Project Baseline Schedules shall utilize the default settings compatible with Primavera 8.3 or current version default settings for the schedule calculations options and automatic cost/resource calculations rules. All other software settings shall not be changed or modified without prior Mobility Authority acceptance

In developing schedules, the DB Contractor shall use schedule software settings similar to Primavera schedule software settings, if not using Primavera, as follows:

- Critical activities shall be defined as Longest Path schedule option setting in lieu of Total Float Less Than or Equal To 10.
- Retained Logic schedule option setting to calculate the Critical Path and controlling activities in the PBS and subsequent schedule updates.
- Critical Path shall be highlighted in red on all schedules to distinguish critical Schedule Activities from other Schedule Activities and Float shown for all Schedule Activities.
- Leveling Resources schedule option shall only be used with prior notification to and concurrence of schedule update procedures by the Mobility Authority.

5.2.4 Schedule of Values

Concurrent with submittal of PBS-2, the DB Contractor shall submit to the Mobility Authority a complete Schedule of Values for all Payment Activities for the Mobility Authority’s approval. The Mobility Authority’s approval of the Schedule of Values shall be a condition of NTP2.

Pertaining to the presentation of the Schedule of Values:

- Payment Activities shall be organized and grouped according to Exhibit C – Attachment 5-2 – Organizational Structure for Cost Reporting. There can be one or more Payment Activities for

each of the lowest (terminal) organizational structure elements referenced in *Exhibit C – Attachment – 5-2 – Organizational Structure for Cost Reporting of the Technical Provisions*. For example, earthwork (organizational Level III) could have one Payment Activity or multiple Payment Activities that roll up costs to the Level III element.

- Each Payment Activity from the PBS shall contain a unique identification number, the activity description, the quantity, the applicable unit, the unit price and scheduled cost value.

The Schedule of Values shall contain separate activities for temporary roads for access, off-site access roads, project clean-up as well as planned maintenance, as applicable, to capture budgeted costs. The DB Contractor’s project management, administration, QA/QC, contingencies and any allowance for inflation, profit and financing, as well as site security shall be linear through all Payment Activities so that the sum of all the Schedule of Values line items equals the total Project cost.

The sum of Payment Activity prices in PBS-2 shall equal the sum of Payment Activity prices in the preliminary Project Baseline Schedule (PBS-1).

5.2.5 Project Baseline Schedule Coding

The DB Contractor shall utilize an activity coding structure for the PBS-2 that allows project activities to be sorted by type of Work and location of Work, or as mutually agreed to by the DB Contractor and the Mobility Authority. Each activity shall be assigned an activity code for each Work element to indicate the type of Work related to the activity. Activity codes shall be project code values and shall be as indicated in **Table 5-2** below.

Table 5-2: “Type of Work” Code Values

Code Value	Description
AGGREGATE	Granular Base
CLEAR&GRUB	Clear & Grub, Removal
DEMO	Building Demolition, Other
DESIGN	Design, studies, RFC package deliverables
DRAINAGE	Pipe, Box Culvert, Headwall
EXCAVATION	Cut, Fill, excavate
FLATWORK	Curb, gutter, sidewalks, shared use path and other non-vehicular paving
LANDSCAPE	Topsoil, mulching, seeding and planting
MOT	Maintenance of Traffic
PAVING	Concrete, Asphalt, etc.
PROCURE	Procurement of materials
ROW	Right-of-Way
SIGNALS	Signals, foundations, poles
SIGNING	Signing – Permanent
STRIPING	Striping – Permanent

Code Value	Description
SUBSTRUCTURE	Foundation, Columns, bent, Piles, Abutments (bridge)
SUPERSTRUCTURE	Girders, Deck, Approach Slabs, Parapet, Polymer Overlay (bridge)
SURCHARGE	Consolidation & Settlement Times
TRAIL	Trails – Pedestrian and Bike
UTILITY-COMM	Utility Communication
UTILITY-GAS	Utility Gas
UTILITY-POWER	Utility Power
UTILITY-WATER	Utility Water/Irrigation/Sewer
UTILITY-OTHER	Other Miscellaneous Utilities
WALLS	Noise, mechanically stabilized earth (MSE), Retaining and Neighborhood
NA	Not Applicable – Not on Mainline, Misc, LOE, etc. (misc. programmatic activities not categorized by Type of Work Code)

5.2.6 Calendars

The DB Contractor shall define calendars as follows:

- The Mobility Authority holidays are non-work days.
- Project calendar descriptions shall begin with a unique project identifier.
- The application of “Standard” Primavera calendars is not acceptable.
- Potential non-work weather days are identified and included in each calendar’s work month.
- Adequately represent non-work days associated with limitations (such as paving seasons, utility shutdown seasons, landscaping seasons, etc.).
- A 7-day calendar to be utilized for cure, settlement, and other activities as appropriate is included.
- Project calendars are assigned consistently among similar activity types.
- All calendars shall be project specific and not global.

5.2.7 Milestones/Constraints

Each milestone schedule deadline shall be separately identified, conform to the scheduling requirements set forth in the milestone schedule, and be assigned a “finish/start on or before” constraint date. The DB Contractor shall include additional milestones in the PBS to define significant events such as NTPs, Substantial Completion, Final Acceptance, start and finish of major segments/areas/regions of Work, major traffic changes, and coordination points with outside entities such as Utilities.

The PBS shall not contain any constrained activities, other than contract milestones, without the Mobility Authority approval. Utilization of constraints following the acceptance of PBS-2 will be allowed only with the Mobility Authority approval.

5.2.8 Activities

The DB Contractor shall describe activities with a unique and logical activity description to easily identify the specific activity so that the scope of work is identifiable and progress on each activity can be measured. Each activity description shall indicate its associated scope and location of Work such as type of Work, bridge number, station to station locations, side of highway, pipe number, etc. and shall include a verb in the activity description to indicate the action undertaken such as install, place, fabricate, etc. Schedule Activities shall be created so that the Work is broken down into similar manageable Work elements with greater detail added as the schedule progresses from PBS-1 to PBS-2 to PBS-3 (for example, bridges shall be broken down minimally into foundations, substructure, superstructure, and deck for PBS-2 and PBS-3.)

The DB Contractor shall define the duration of each activity and shall limit the maximum duration according to **Table 5-1** unless otherwise approved by the Mobility Authority. Exceptions could include non-Work type activities such as mobilization, design, fabrication, settlement durations, curing, and long lead procurement items. The duration for each activity shall be the time required to complete the Work based on the quantity of Work divided by reasonably anticipated production rates when applicable. Separate activities for cure time, major inspection points requiring preparation, submittal periods, environmental approvals and other time consuming activities shall be included.

The DB Contractor shall clearly identify the relationships and logic that tie activities together. Each activity is to have at least one predecessor and one successor activity, except for NTP and Substantial Completion milestones. Unnecessary relationships or excessive ties to end milestones shall be avoided.

5.2.9 Changes

The DB Contractor shall revise the cost loading during the course of the Project in a Revised PBS if it becomes necessary to add, combine, eliminate, or modify Payment Activities or Schedule Activities to reflect modifications to the Work due to an executed Change Order. Change Orders as approved by the Mobility Authority shall be added into the schedule with appropriate activities, resources, and units/budget to represent the modified scope of work. A WBS level for each executed Change Order shall be added under the “Change Modification” level of the cost breakdown structure in Exhibit C – Attachment 5-2 – Organizational Structure for Cost Reporting. All costs, if applicable, shall be mapped to the Change Order WBS level accordingly.

If applicable, revisions to the PBS and consequent realignment of funds between Payment Activities shall be requested by the DB Contractor through Proposed Change Order (PCO) Notices. The total cost in the schedule shall match the total Project cost inclusive of all approved Change Orders. As activities are added

or split out in the course of revising a schedule update, units/budget for those activities shall also be reallocated to represent the appropriate quantity to accomplish the Work within the activity duration.

All executed Change Orders shall be incorporated into the originally planned execution of the Work.

The DB Contractor shall submit to the Mobility Authority a Revised Project Baseline Schedule within 14 days after each Change Order is executed. All approved Change Orders shall be incorporated into the originally planned execution of the Work. The Mobility Authority will confirm in writing the acceptance of each Revised Project Baseline Schedule. The accepted Project Baseline Schedule or current accepted Revised Project Baseline Schedule shall remain in force until a subsequent Revised Project Baseline Schedule is accepted.

A revised Schedule of Values as derived from a revised PBS shall be submitted within 14 days after the respective Change Order is executed. The Mobility Authority will review the submittal and within 21 days of submission, return it to the DB Contractor as accepted or returned for resubmission.

5.2.10 Float

Float shall not be used to the financial detriment of either party. Any schedule, including the PBS-2 and all updates thereto, showing an early Substantial Completion date shall show the time between the scheduled Substantial Completion date and the applicable milestone schedule deadline as the “Total Float” of the Project.

The DB Contractor shall not sequester total Project Float through manipulating calendars, extending activities durations or any other such methodology. Float suppression techniques, negative float, and Schedule Activity durations, logic ties, and/or sequences deemed unreasonable by the Mobility Authority shall not be used. Float shall not be considered as time for the exclusive use of or benefit of either the Mobility Authority or the DB Contractor but shall be considered as a jointly owned, expiring resource available to the Project.

5.2.11 Narrative

The DB Contractor shall provide a schedule narrative with each PBS submittal as follows:

- Describe the general sequence of Work and how the DB Contractor intends to meet all milestones and Completion Deadlines.
- Describe the construction philosophy supporting the work plan and approach to the Work outlined in the PBS.
- Describe the approach used to apply relationships between activities, such as physical or chronological relationships between Work activities, sequencing due to crew or equipment resources, or timing of Work based on limitations (such as ROW, environmental, utilities, etc.).

- Describe any limited resources, potential conflicts, or other salient items that may affect the schedule and how they may be resolved.
- Describe the Critical Path and identify challenges that may arise associated with the Critical Path.
- Describe adverse weather sources and calculations used for assumptions in determining potential non-work weather days.
- Describe activity coding structures and how they will be used.
- Provide a list of planned resources describing crews, crew size, major equipment, and production rates. Only planned resources available to the DB Contractor shall be included in the work force listing.
- Provide a list of applicable activities and justification for usage of:
 - Activities with durations exceeding 20 days.
 - Constraints.
 - Unusual calendars.
 - Assumptions and calculations for non-work weather days added to calendars.
 - Lag.

Along with the schedule narrative, the DB Contractor shall include layouts generated from the scheduling software (PDF file) to illustrate the following:

- The DB Contractor’s approach to Work (based on WBS or other applicable coding) including, at a minimum, columns for activity id, activity name, start, finish, original duration, remaining duration, total float, Critical Path, budgeted cost, and Gantt chart.
- Critical Path layout.
- Other layouts or reports as agreed upon with the Mobility Authority.

The DB Contractor shall submit a hardcopy color plot as well as an electronic version of the schedule in its native format for each submittal along with the PBS narrative.

5.2.12 Project Baseline Schedule Submission

The DB Contractor shall establish a sequential numbering system for schedule submittals and associated reports to allow easy identification of the PBS, schedule updates and resubmissions. All schedules, charts and diagrams shall display the project title, the data date and a legend indicating the various symbols used and their meanings. The DB Contractor shall provide the following for each schedule submittal:

- One electronic copy in native software of the schedule.

- One electronic copy in pdf format of the narrative report.
- One electronic copy in pdf format of layouts as generated from the scheduling software.

5.2.13 Utility, Railroad, and Other Third Party Submittals

All PBS submittals shall include an additional, separate, filtered list of Project activities and sub-activities included in the Project for coordinating with and accomplishing items associated with private and public utilities, the Railroads, and other private or public third party. These activities shall also be presented in the body of the PBS. Requirements for the PBS, updates, and accepted PBS shall also apply to all private and public utilities, Railroad, and other 3rd party tasks.

Railroad Coordination. The Project traverses over UPRR property as described in *Technical Provisions 6.* The DB Contractor shall coordinate with UPRR to schedule activities with the operation of the railroads, as needed.

5.2.14 System Integrator Coordination

The DB Contractor shall incorporate the System Integrator (SI) schedule into the PBS. The DB Contractor shall incorporate the SI schedule milestones dates for installation, operational testing and commissioning testing of the toll systems at the Substantial Completion Gentries as described in *Technical Provisions 21.* The DB Contractor shall meet with the SI to ensure the SI’s scheduled tasks, dependencies, and durations are accurately incorporated.

5.3 Project Status Schedule Updates

5.3.1 General Requirements

The DB Contractor shall provide Project Status Schedule Updates that comply with all PBS requirements. The DB Contractor shall use the 25th of each month and as the data date and shall submit the monthly update on or before the 27th of each month. No changes in activity durations, calendar assignments, logic ties, or constraints will be allowed without the Mobility Authority’s written approval. Such changes shall be submitted in a Revised PBS.

The DB Contractor shall show actual progress for each activity in the schedule updates such as:

- Actual start and finish dates for completed activities.
- Actual start dates, physical percent complete and remaining duration for activities in progress.
- Projected sequences of activities for future Work.
- Revised relationships and durations for unfinished activities, if warranted.
- A well-defined Critical Path.

For each schedule update, the DB Contractor shall ensure that:

- Planned budget values match total Project cost or revised total Project cost inclusive of all authorized Change Orders.
- All planning changes, adjustments, or revisions in sequencing and timing of the remaining Work are accurately represented.

If Work is performed out of sequence, the DB Contractor is required to implement logic changes consistent with the retained logic method of scheduling to allow the out-of-sequence Work to proceed.

Through schedule updates, the DB Contractor may demonstrate proposed modifications to planned Work that require adding or deleting activities, changing activity descriptions, or revising activity durations or logic that are consistent with the following requirements:

- No changes are to disrupt the integrity or comparative relationship between current and previously accepted PBS or schedule updates.
- An activity ID can only be used once (i.e., do not delete an activity then create a new activity at a later date utilizing the same activity ID).
- Activity descriptions may be revised for clarification, but are not to be altered to represent a different scope than originally intended. For example, an earthwork activity may be further defined by adding station limits but the description cannot be changed to concrete paving with related logic ties.
- If changes impacting the Critical Path result in an extension of the Substantial Completion Deadline, beyond contractual limits, the DB Contractor shall be required to submit a time impact analysis.

5.3.2 Narrative

The DB Contractor shall provide a narrative with each schedule update submittal which addresses each of the following:

- Description of the Work performed during the progress period. Describe progress for each segment/section and the Project as a whole, including all phases of Work and interim milestones organized and reported by the defined WBS.
- Provide a summary of QA/QC issues that can potentially affect the CPM model.
- Explanation of deviations between the Work planned and the Work performed for the period.
- Description of the Work to be accomplished during the next period.
- Description of the current Critical Path of the Project, explaining any changes since the previous update as well as potential issues and proposed resolutions.

- Explanation of significant changes to the PBS since the previous update.
 - Provide the reason or justification for the changes, and
 - Describe any resulting affects or impacts to the PBS. Particular focus should be on any changes that affect the Critical Path.
- Explain changes to:
 - i. Calendar.
 - ii. Activity unit/ budget allocations.
 - iii. Planned resource (crew) allocations that deviate from the baseline Work plan
 - iv. Critical Path.
- Identification of requested and/or required Mobility Authority actions, if applicable, for the next month.
- Status on pending items applicable to the schedule such as:
 - Permits, easements, agreements.
 - Contract changes or time adjustments.
 - Change Orders that were executed during the period from the submission of the previous month's progress report to the submission of the current progress report.
 - Time Impact Analyses.
- Current and anticipated problems or delays including:
 - Listing of current/anticipated problems and/or delays with cause and effect on Work, milestones and completion dates. A summary of the resolutions (status) to the problems and/or delays listed above (resolved, ongoing or anticipated).
 - The DB Contractor's plans on how to mitigate or resolve ongoing and/or anticipated problem and/or delays.
 - Identification of action the Mobility Authority needs to take and required timeline for actions to be taken, to avoid or mitigate the problem.
- A discussion of problems or delay in the schedule update narrative does not relieve the DB Contractor of complying with contractual requirements regarding notification and documentation of claims.
- If any actual dates are changed or corrected in any following month, the DB Contractor shall submit a separate narrative with the schedule update providing an explanation of the change.

Along with the schedule update narrative, the DB Contractor shall include layouts generated from the scheduling software, in pdf format, to illustrate the following:

- Layout to demonstrate the DB Contractor's approach and progress of Work based on WBS or other applicable coding. At a minimum include columns for activity id, activity name, start, finish, original duration, remaining duration, total float, budgeted cost, and Gantt chart. The Gantt chart shall contain current planned bars and baseline / target bars that represent the previous period's progress forecast.
- Critical Path layout organized by WBS and sorted by early start.
- A 90-day look ahead Gantt chart showing all upcoming Submittals from the DB Contractor and approvals required by the Mobility Authority or other Governmental Entities.
- A 90-day look ahead Gantt chart grouped by WBS and sorted by early start date.
- Graphical report which compares the DB Contractor's actual monthly progress to the previous months planned progress, organized by WBS.
- A 90-day look ahead Gantt chart of Design document submittals for the forthcoming period.
- Monthly expenditure projections and cash expenditure curves by WBS or as requested by the Mobility Authority, if applicable.
- Other layouts or reports as agreed upon or requested by the Mobility Authority.

Progress payment requests, if applicable, shall accompany the schedule update narrative.

In addition to the schedule update narrative, the DB Contractor shall provide a separate report on the milestone schedule deadlines showing the schedule dates for the immediate prior month and the current month. For variances greater than 30 Days, the DB Contractor shall include a narrative to explain why the dates have changed.

5.3.3 Submittal Requirements

The DB Contractor shall submit to the Mobility Authority the schedule update, narrative and agreed upon layouts or reports each month for the duration of the DB Contract beginning with the first full month after NTP2. The DB Contractor shall provide the following for each schedule update submittal:

- One electronic copy in native software of the schedule file.
- One electronic copy in pdf format of narrative report.
- One electronic copy in pdf format of agreed upon, layouts/reports as generated from the scheduling software.
- The project narrative as described in Technical Provisions 5.3.2 above.

The Mobility Authority will review schedule updates for consistency with the DB Contractor's WBS and the currently accepted PBS and for conformance with the Contract Documents. The Mobility Authority will review the Project Status Schedule Update submittal within 21 days of submission, return it to the DB Contractor either as accepted or accepted with comments to be addressed in the following Project Status Schedule Update. The DB Contractor shall repeat the submittal process until receiving Mobility Authority acceptance of the Project Status Schedule Update.

Acceptance of the Project Status Schedule Update is required prior to submittal of the associated Draw Request.

The Mobility Authority's review and acceptance of the Project Status Schedule Update is for consistency with the DB Contractor's WBS and the currently accepted PBS, and conformance to the requirements of the Contract Documents only and does not relieve the DB Contractor of any responsibility for meeting any Completion Deadlines. Review and acceptance does not expressly or by implication warrant, acknowledge, or admit the reasonableness of the logic or durations of the Project Status Schedule Update. If the DB Contractor fails to define any element of work, activity, or logic and the Mobility Authority's review does not detect this omission or error, the DB Contractor is responsible for correcting the error or omission.

5.4 As-Built Schedule

Upon completion of the Punch List, the DB Contractor shall submit the schedule update identified as the "as-built schedule." The as-built schedule shall reflect the exact manner in which the Work up to each Final Acceptance and described by the Contract Documents was actually performed including start and completion dates, Schedule Activities, actual durations, sequences and logic.

5.5 Time Impact Analysis

The DB Contractor shall submit to the Mobility Authority a written time impact analysis (TIA) in each of the following situations:

- As part of a PCO Notice based on a delay as set forth in Contract Documents.
- If any changes in a schedule update impact the Critical Path, such that they create an extension of Substantial Completion beyond the Substantial Completion Deadline.
- If the DB Contractor has claim for delay. The DB Contractor shall submit a separate TIA for each delay event.

The Mobility Authority may request, at any time, a TIA demonstrating impact or potential impact to the schedule resulting from claimed delays or Change Orders which are being negotiated between the Mobility Authority and the DB Contractor. If the Mobility Authority requests a TIA, the DB Contractor shall submit the requested TIA within 15 Days of receiving the request. The Mobility Authority will return the TIA to the DB Contractor as approved or not approved with comments to be incorporated for resubmission within

7 days of receipt by the DB Contractor. The submittal process shall be repeated until receiving the Mobility Authority approval of the submittal.

Time Impact Analysis shall be performed by using the following process:

1. Establish the status of the project immediately before the impact: Model the impact. A small schedule (Fragnet) should be created that details the impact. This should be accepted by TxDOT and the Contractor before moving on to step 2.
2. Predict the effect of the impact on the schedule update used in Step 1: Select the appropriate schedule to include the impact in. This should be the last accepted schedule before the delay event was identified.
3. Track the effects of the impact on the schedule during its occurrence: Insert the fragnet. A copy of the last accepted schedule is created and the fragnet is added and logically tied into the schedule.
4. Establish the status of the project after the impact is complete: Compute the schedule and note any change to project completion. Take into account mitigating circumstances to maintain project progress during the delay.

Submission of a TIA does not relieve the DB Contractor of complying with all contractual requirements regarding notification and documentation of potential Change Orders and Change Orders.

Time extensions will only be considered if:

- The delay event is demonstrated to affect the controlling operation on the Critical Path. Changes that do not affect the Critical Path will not be considered as the basis for a time adjustment.
- The total float is absorbed and the scheduled completion date is delayed one or more Working Days because of the change or impact.
- In the case of multiple lines of negative Float, the change or delay must cause the affected path to exceed all others before a time extension will be granted.

Each TIA submitted by the DB Contractor shall consist of the following steps or elements:

- Establish the status of the Project before the impact by using the most recent schedule update that has the closest data date prior to the event for TIA, or as adjusted by mutual agreement.
- Identify the impact event, estimate duration of the impact, determine appropriate logic, and insert the impact activity or fragnet of activities into the schedule. Initiate a new forward and backward calculation of the activity network (i.e. the “Schedule” command in Primavera).

- Demonstrate any resulting affects from the impact through layouts generated from the scheduling software. Filter activities to show added or modified activities and activities impacted from changes. Note any other changes made to the schedule including modifications to the calendars or constraints.
- If the current Project Status Schedule Update is revised subsequent to submittal of a time impact analysis but prior to its acceptance, the DB Contractor shall promptly indicate, in writing, to the Mobility Authority the need for any modification to its time impact analysis.

The DB Contractor shall submit the following with each TIA Submittal:

- A narrative report which:
 - Identifies the schedule update(s) used for analysis.
 - Describes the procedures used to analyze schedule impacts, including:
 - i. Additions, deletions, or modification to activities and or fragnets.
 - ii. Modifications to the calendars or constraints.
 - iii. Modifications to relationships.
 - Describes the impact or potential impact by comparing Work prior to the impact and Work affected or predicted to be affected after the impact.
 - Describe mitigation efforts taken to date.
 - Describe potential resolutions to mitigate or avoid impact.
- Schedule layouts in pdf file format. Filter activities to clearly show impacted activities and affects to the Critical Path. Multiple layouts may be required to adequately demonstrate the impact to the Critical Path. At a minimum, provide a layout demonstrating associated activities prior to the impact and a layout demonstrating associated activities after the impact is inserted and the schedule is progressed.
- One electronic copy in native software of the impacted PBS.
- Other information or documentation pertinent to the analysis.

Incorporation of TIA activities into the current schedule update submittal requires the Mobility Authority approval.

5.6 Recovery Schedule

If the Work is delayed to the Substantial Completion Deadline for a period which exceeds the lesser of either 30 days in the aggregate or that number of days in the aggregate equal to 5% of the days remaining until Substantial Completion, the DB Contractor shall submit a Recovery Schedule demonstrating the proposed plan to regain lost schedule progress and to achieve Substantial Completion by the specified date.

The accepted Recovery Schedule shall remain in force until a subsequent Revised Project Baseline Schedule is accepted.

If the Recovery Schedule is required hereunder, the DB Contractor shall have no right to receive settlement of a payment request until such time as the DB Contractor has prepared and the Mobility Authority has accepted the Recovery Schedule.

If the PBS schedule performance index values of the Project Construction scope falls below 0.65 with negative trending for 4 consecutive update periods, the Mobility Authority has the option of requiring the DB Contractor to resource load the remaining construction activities and perform a resource analysis of the required work force.

5.7 Submittals

Table 5-3: Submittals to Mobility Authority

Submittals	Submittal Schedule	Mobility Authority Action	Reference Section
Project Baseline Schedule 2 (PBS-2)	Prior to issuance of NTP 2 and prior to submitting the first Draw Request for payment of any NTP 2 Work, and updated monthly until PBS3 is accepted	Review and Acceptance	5.2.1
Project Baseline Schedule 3 (PBS-3)	PBS-3 shall be submitted within 90 days of NTP 2	Review and Acceptance	5.2.1
Revised Project Baseline Schedule	1. If Applicable, 2. 14 days after each Change Order is executed	Review and Acceptance	5.2.1
Schedule of Values	Concurrent with submittal of PBS-2	Review and Acceptance	5.2.4
Revised Schedule of Values	14 days after each Change Order is executed	Review and Acceptance	5.2.9
Project Status Schedule Updates	On or before the 27th of each month	Acceptance	5.3.1
As-Built Schedule	Upon completion of the Punch List	Acceptance	5.4

Table 5-3: Submittals to Mobility Authority

Submittals	Submittal Schedule	Mobility Authority Action	Reference Section
Time Impact Analysis (TIA)	<p>As part of a PCO Notice based on a delay as set forth in Contract Documents.</p> <p>If any changes in a schedule update impact the Critical Path, such that they create an extension of Substantial Completion beyond the Substantial Completion Deadline.</p> <p>If the DB Contractor has claim for delay.</p> <p>within 15 Days of receiving the request from MA</p>	Approval	5.5

6.0 RAILROAD COORDINATION

6.1 General Requirements

The DB Contractor shall perform minor work consisting of pavement marking operations on the US 183 bridges over the Union Pacific Railroad (UPRR) crossings (DOT #975136F, 435971R, and 975137M) as shown in Figure 1.

The DB Contractor shall coordinate with the Mobility Authority when preparing a notification letter to the UPRR describing the proposed work in accordance with Exhibit C - Attachment 6-1 – UPRR Scope of Work. The DB Contractor shall submit the notification letter and obtain all necessary approvals prior to the commencement of pavement marking operations.

The DB Contractor is required to obtain the requisite insurance specified in Exhibit C - Attachment 6-1 – UPRR Scope of Work.



Figure 6-1: 183 North Mobility Project – UPRR Crossing Locations

6.2 Submittals

Table 6-1: Submittals to Mobility Authority

Submittals	Submittal Schedule	Mobility Authority Action	Reference Section
Copies of insurance policies	Prior to work over UPRR	For Information	6.1
Notification letter to UPRR	Prior to work over UPRR	For information	6.1

7.0 RIGHT-OF-WAY

7.1 General

The Schematic ROW as depicted on the Schematic Design is anticipated to be sufficient to construct the Project. The Mobility Authority shall make the Schematic ROW available to the DB Contractor within 180 days after issuance of NTP1 subject to the conditions described in Section 6.6.1 of the DBA.

If the DB Contractor is required to acquire additional ROW for new or modifications to the water quality ponds (BMPs) to address water quality and flow rate control, then the DB Contractor shall perform such ROW acquisition in accordance with this Technical Provision 7.

The DB Contractor shall be responsible for obtaining temporary easements, including temporary easements for driveways as generally shown on the Driveway Exhibits in Exhibit D – Item 3– Technical (Roadway), and the DB Contractor-Designated ROW in accordance with the requirements identified in this Technical Provision 7.

7.1.1 Standards

Any DB Contractor acquisition of any ROW constituting the Final ROW shall be acquired in accordance with the practices, guidelines, procedures, and methods contained in the following:

- TxDOT ROW Manuals (available online at <http://onlinemanuals.txdot.gov/manuals>)
- TxDOT Access Management Manual
- TxDOT Survey Manual
- TxDOT Real Estate Acquisition Guide for Local Public Agencies
- TxDOT Appraisal and Review Manual
- TxDOT Project Development Process Manual
- FHWA’s Right-of-Way Project Development Guide (FAPG)
- Uniform Relocation and Real Property Acquisition Policies Act of 1970, as amended, and 23 CFR part 710
- Texas Government Code Sec. 402.031
- Texas Property Code
- State of Texas Landowner’s Bill of Rights

7.1.2 Personnel Qualifications

The DB Contractor's Acquisition Manager shall:

- Have at least five years' experience managing the acquisition of transportation ROW projects for a condemning authority.
- Be licensed as a real estate salesman or broker pursuant to the Texas Real Estate License Act or rules established by the TREC.
- Be familiar with appraisal and appraisal report review pursuant to the USPAP.
- Be familiar with the Uniform Act and applicable Laws of the State of Texas.
- Have managed no less than 200 parcels.

7.2 Schematic Right-of-Way and Documents

The Schematic depicts existing ROW sufficient to meet the Schematic ROW needs to construct the Project. It shall be the responsibility of the DB Contractor to adequately mark in the field the limits depicted on these maps in order to control and limit its operations to these areas.

7.3 DB Contractor Responsibilities

Design Within Final ROW. The DB Contractor shall provide a Project Design that stays within the Final ROW boundaries provided by the Mobility Authority.

Required Property Rights. The DB Contractor may not begin construction on any Final ROW unless property rights have been conveyed and recorded in favor of the State of Texas, or unless a possession and use agreement has been validly executed, delivered by all necessary parties, and approved by the Mobility Authority.

Clearance/Demolition of Schematic ROW

Following acquisition or possession of any parcel of the Schematic ROW, the DB Contractor shall:

- Perform any and all slab and below ground demolition needed to meet the needs of the Project. Miscellaneous removal and disposal operations shall be performed consistent with the applicable provisions of the TxDOT *Standard Specifications of Construction and Maintenance of Highways, Streets, and Bridges*, adopted by TxDOT in November 2014 and applicable Law.
- Cap wells and acquire any permits required for Governmental Approvals, as specified in *Technical Provision 9*. All parcels in the Schematic ROW that contain wells shall have wells capped prior to any construction activities.

- Notify the Mobility Authority upon completion of the demolition and clearance of the Schematic ROW, as applicable.

7.4 DB Contractor-Designated ROW Acquisition and Use

DB Contractor-Designated ROW. If the DB Contractor identifies a need for permanent ROW, the DB Contractor shall be responsible for the costs of all services and preparation of certain documentation for acquisition, permitting, and related relocation assistance. The DB Contractor acknowledges that it has incorporated the value of saleable improvements not retained by the property owner into the Design-Build Price and that the DB Contractor shall retain the rights to said saleable improvements.

The DB Contractor's work effort related to the DB Contractor-Designated ROW acquisition includes, but is not limited to, mapping, surveying, appraisal, appraisal review, negotiation, acquisition services, procurement of title insurance, clearing of title, closing of acquisitions, condemnation support, relocation assistance, clearance/demolition of improvements, and environmental testing and remediation as required as well as all other fees and expenses. Fees and expenses shall include, but not limited to, all required exhibits and photos associated with condemnation services and proceedings.

The DB Contractor shall be responsible for acquiring any site needed for its construction activities or materials storage that is outside of the TxDOT ROW. The DB Contractor may also, at its own discretion, negotiate temporary easements for construction activities or staging areas with landowners. The Mobility Authority shall not be obligated to exercise its power of eminent domain in connection with the DB Contractor's acquisition of any such temporary right or interest, and the Mobility Authority shall have no obligations or responsibilities with respect to the acquisition, maintenance or disposition of such temporary rights or interests.

Identification of Correspondence. All correspondence with the Mobility Authority relating to acquisition of real property by the DB Contractor shall include the following identifying information (at a minimum) as a heading:

- County Name.
- Mobility Authority Project Numbers.
- Project Name.
- Project limits.
- Parcel number.
- Name of record owner(s).

Legal Proceedings. If needed, the DB Contractor's staff shall testify as expert witnesses (or the DB Contractor shall provide expert witnesses approved by the Mobility Authority) for any eminent domain proceedings associated with the DB Contractor-Designated ROW or Mobility Authority acquired parcels,

and shall be available (as directed by the Mobility Authority) for depositions; other discovery, prehearing, or pretrial meetings; and appeals. Upon request, the DB Contractor shall prepare and deliver to the Mobility Authority a copy of all related file documents.

7.4.1 Description of Services

The DB Contractor shall complete and provide the following services as it relates to the DB Contractor-Designated ROW of the Project. The DB Contractor must obtain Mobility Authority approval prior to commencing ROW activities, including selection of independent fee appraisers. Upon receiving Mobility Authority approval for right of way acquisition of specific parcels, the DB Contractor shall provide the property owner an introduction letter sent by certified mail, return receipt requested. The letter shall contain specific information regarding who will be the contact for the DB Contractor. The Texas Landowner's Bill of Rights shall be attached to the introduction letter. In instances where the letter is being sent to the last known property owner shown on the tax rolls, an additional letter should be sent to any other address if the person on the tax rolls is not the same as the person listed in the title commitment as being the owner.

The DB Contractor must obtain the Mobility Authority's approval of all appraisals, requests to acquire the DB Contractor-Designated ROW, acquisition documentation, and requests to commence condemnation proceedings. In connection with the acquisition of any DB Contractor-Designated ROW, the DB Contractor shall comply with all of the requirements of this Technical Provision 7 applicable to such acquisition.

7.4.1.1 Title Service

With respect to title services for the DB Contractor-Designated ROW, the DB Contractor shall:

Select and contract with one or more title companies approved by the Mobility Authority. Title service shall include the delivery to the Mobility Authority a 5-year sales history, a preliminary title commitment or preliminary title report and, if necessary or appropriate, with copies of all underlying documents and a plot of all easements, including but not limited to Existing Utility Property Interests, referenced therein for each parcel (including fee acquisitions, slope easements, other drainage and roadway right of way or easements and abandonment of utility easements) to be acquired by the Mobility Authority for the Project. Each title report shall be dated not more than 90 days prior to the date of submittal of the acquisition package for such parcel to the Mobility Authority. The DB Contractor shall, at its own cost, review each title report to ensure that it complies with the format required by this Technical Provision 7. All title reports must be in the required format, clearly indicate which exclusions and exceptions shall be deleted upon acquisition of the subject parcel, and clearly indicate any required deliveries to the title company to clear identified exclusions and exceptions.

Review the preliminary title commitment or report to ensure that all current owners of record title are contacted and that negotiations or condemnation actions are conducted with all appropriate parties.

Work with the current owners of record title to each parcel or interest in a parcel or their designee and all other appropriate parties to clear any title exceptions or exclusions not acceptable to the Mobility Authority.

Secure an owner's policy of title insurance in the amount of the total acquisition cost for each parcel from a title company acceptable to the Mobility Authority for each parcel acquired, insuring title as required by the Mobility Authority. All DB Contractor-Designated ROW shall be acquired, and the Mobility Authority's title in the DB Contractor-Designated ROW shall be insured, in fee simple absolute or easement interest as appropriate, free and clear of any and all liens and encumbrances. The DB Contractor shall pay the applicable title company for the cost of the title policies, including all endorsements thereto required by the Mobility Authority, which title policies must be in form and substance approved by the Mobility Authority. Title to the DB Contractor-Designated ROW shall be insured in the name of the State of Texas.

7.4.1.2 *Appraisal Services*

The DB Contractor shall provide the Mobility Authority with fair market value appraisals prepared by appraisers meeting the minimum qualifications established herein for DB Contractor-Designated ROW. All appraisals shall be prepared in conformance with Law (including the *Uniform Relocation Assistance and Real Property Acquisitions Policies Act of 1970, Public Law 91-646* as amended), and in accordance with professional appraisal methods and applicable standards for all parcels to be acquired by the Mobility Authority. A hazardous waste/materials investigation report will accompany each appraisal report as defined in *Technical Provision 9* unless waived by the Mobility Authority in its sole discretion. The DB Contractor shall:

- Establish personal pre-appraisal contact with each owner of record title and each occupant, and document all contacts.
- Contact the record title owners or their designated representatives, in writing, to offer them the opportunity to accompany the appraiser on the appraiser's inspection of the parcel, and maintain a record of all such contacts in the parcel file.
- Prepare a complete appraisal report for each parcel to be acquired. The appraisal reports shall comply with and include all matters required by this *Technical Provision 7.4.1.2* and the related manuals, as specified in *Technical Provision 7.1*, and shall satisfy the requirements of the Appraisal Foundation's *Uniform Standards of Professional Appraisal Practices (USPAP)* in effect at the time the appraisal is submitted. Appraisal Reports shall be prepared using TxDOT Form ROW-A-5. Special analyses, studies or reports, as necessary, shall be made a part of each appraisal.
- Obtain and provide the Mobility Authority with copies of all written leases, licenses and other occupancy agreements to identify lessees, licensee and other occupants with potential compensable interests in each parcel and to determine the value of each such interest.
- Testify as an expert witness(es) or provide expert witness(es), approved by the Mobility Authority, in special hearings or eminent domain proceedings and be available for depositions, other discovery, pre-hearing or pre-trial meetings and appeals, as directed by the Mobility

Authority. The DB Contractor shall also provide administrative and/or technical support for such proceedings as requested by the Mobility Authority.

- Coordinate with the review appraiser regarding corrections and/or additional information that may be required for a particular appraisal.
- Cause a report to be prepared by a Licensed Site Professional in the State of Texas for documenting the environmental condition of each parcel; reports may be based on field investigations and/or historical review, as appropriate for the particular parcel. The report shall be completed in coordination with the appraiser(s) and shall be available to the appraiser(s) prior to completion of the required appraisal reports. The report must indicate the approximate cost to remediate the parcel to achieve its current use and its highest and best use based on available technology for the purpose of permitting the DB Contractor's appraiser(s) to estimate the effect, if any, that the environmental condition of the parcel has on its fair market value. Prepare timely written notification to the Mobility Authority of any environmental or other concerns associated with the Project Design to be acquired that could require environmental remediation or other special attention.
- Confirm and analyze local ordinances for meter supply backflow preventers and/or other special conditions. The installation of any such appurtenances on the parcel remainder shall be addressed in the appraisal report, and shall be included as part of the compensation package to the landowner.
- The DB Contractor shall prepare updated appraisals, as well as updated appraisal reviews, when required by the Mobility Authority or as needed during eminent domain proceedings.
- Prepare and deliver to the Mobility Authority upon request, a copy of all file documents, as formally requested in discovery motions or request for production.
- Prepare and deliver to the Mobility Authority a Property Classification Agreement.

7.4.1.3 *Appraisal Review*

In connection with appraisal review for DB Contractor-Designated ROW, the DB Contractor shall:

- Select review appraisers, acceptable to the Mobility Authority, to review the work effort described in Technical Provision 7.4.1.2.
- Perform an evaluation of all outdoor advertising signs, as required, utilizing the appropriate forms, sign schedule and/or as instructed by the Mobility Authority.
- Determine, in consultation with the Mobility Authority, if additional appraisal reports or technical expert reports are required. Initiate, review, and reconcile each report as required.
- Review all appraisal reports for each parcel to determine consistency of methodology, supporting documentation related to the conclusion reached, and compliance with the Mobility Authority requirements, as defined in Technical Provision 7.1, Technical Provision 7.4.1.2,

this *Technical Provision 7.4.1.3*, and the Appraisal Foundation's *Uniform Standards of Professional Appraisal Practices* (USPAP) in effect at the time the appraisal is reviewed.

Upon completion of the review outlined above, the appraiser shall certify in writing to the Mobility Authority that all standards indicated above have been met.

7.4.1.4 DB Contractor-Designated ROW Acquisition Package Approval

Acquisition packages for DB Contractor-Designated ROW submitted by the DB Contractor for the Mobility Authority approval shall include the following items prepared in accordance with the requirements of this *Technical Provision 7*:

- A copy of the signed receipt of the land owner bill of rights.
- A complete legal description of the parcel, noting the form of granting instrument (fee, easement, etc.) adequate to effect the desired acquisition of the parcel, signed and sealed by a Land Surveyor licensed to practice in the State of Texas. A separate legal description shall be required for each parcel. All descriptions shall be in recordable form and shall be prepared in a form and manner acceptable to the Mobility Authority in all respects.
- GIS files of the Acquisition Survey Documents in accordance with the standards and required deliverables detailed in Chapter 4, Volume 1 of the TxDOT ROW Manual. The DB Contractor shall submit GIS files concurrent with the Acquisition Survey Document and prior to submitting the first Acquisition Package and provide updates as needed.
- A parcel plat, as prepared by the Land Surveyor, and a half size copy of the right of way map pertaining to the parcel. The DB Contractor shall revise the Schematic and Documents as required to reflect the Additional Properties.
- A control of access document identifying the rights of access from the unacquired remainder property to the Project.
- An approved right of way justification statement, justifying the acquisition of the parcel, including the parcel number, owner's name(s), location, nature of acquisition (fee, permanent easement, etc.), physical dimensions, and limits of the acquisition.
- A title report, current within 90 days, including copies of all documents identified in the exceptions listed therein and a plot of all easements identified therein. The acquisition package shall include the DB Contractor's analysis of each preliminary title report or title commitment to determine potential problems and proposed methods to cure title deficiencies. The DB Contractor shall perform title curative Design/Build Work. The DB Contractor will provide the Mobility Authority with copies of all curative documents.
- A copy of the appraisal report (previously reviewed and approved by the Mobility Authority), and all supporting documentation and appropriate Hazardous Materials certifications.

- A real/personal property report detailing what items making up each parcel are classified as real estate, tenant-owned improvements or personal property. Particular attention should be paid to items which have questionable classifications.
- A relocation plan for carrying out required relocation assistance activities as described in *Technical Provision 7.4.1.7*, below. The DB Contractor shall include all necessary Working and relocation plans, relocation estimates, and appropriate forms to reflect benefits of the parcel. Such plans and estimates shall be prepared by a qualified consultant, in conformance with standard relocation procedures and applicable state Laws and regulations.
- The proposed initial offer letter, memorandum of agreement, deed, and any other documents, which shall be prepared by the DB Contractor as required or requested by the Mobility Authority.
- Any other required Mobility Authority forms, such as record of all contacts with the Property Owner or any party with a compensable interest.
- A confirmation statement that a Texas licensed attorney, who has at least 3 years' experience in the acquisition of ROW for projects with a condemning authority, and who is familiar with the Uniform Act and other applicable Laws, has been retained by the DB Contractor and has reviewed and approved the conveyance instruments prepared by the DB Contractor for the parcel and the title report.
- Any environmental site assessments prepared for the parcel.

Upon the Mobility Authority's approval of the acquisition package, the DB Contractor may proceed with the offer to the property owner.

The DB Contractor shall provide an advance notice to the Mobility Authority a minimum of 10 Business Days prior to submitting a DB Contractor-Designated ROW Acquisition Package and the Mobility Authority will have 10 Business days after receipt of each package to review and either provide comments or approve the acquisition package.

7.4.1.5 *Right-of-Way Negotiations*

The DB Contractor shall conduct all negotiations for DB Contractor-Designated ROW in accordance with the requirements of the governing Laws and guidelines. In conjunction with negotiations, the DB Contractor shall:

- Within 10 Business Days of the Mobility Authority's approval of the acquisition package, contact each property owner or owner's designated representative, in person where practical, to present the offer and deliver an appraisal report and appropriate brochures. The initial offer must be in writing and also sent by certified mail, return receipt requested. Any appraisals produced for this property in the previous 10 years shall be disclosed to the property owner. The Texas Landowner's Bill of Rights will also be delivered to the property owner upon

presentation of the initial offer. Provide a copy of the appraisal report for the subject property only to the property owner or authorized representative at the time of offer and maintain a file record of receipt of appraisal signed by the property owner. The DB Contractor shall also maintain follow-up contacts and secure the necessary documentation and title curative Work upon acceptance of the purchase offer.

- Produce and distribute to all property owners and displacees, approved informational brochures as appropriate.
- Identify lessees, licensees, occupants, or other parties with potential compensable interests and, if appropriate, after consultation with the Mobility Authority, negotiate with such parties for the acquisition of their compensable interests.
- Provide timely (i.e., not more than 10 Business Days after inquiry) response to the verbal or written inquiries of any property owner, lessee, licensee, occupant or other holder of a compensable interest, as applicable and in conformance with practices, guidelines, procedures, and methods contained in the publications listed in Technical Provision 7.1.
- Prepare a separate negotiator contact report for each meeting or conversation with any person (or their appointed representative(s) supported by a written confirmation of appointment) who has a compensable interest in each parcel.
- Maintain a complete parcel file for each parcel. All original documentation related to the purchase of the real property interests will be maintained (housed separately from the relocation files) in conformance with standards, manuals, and procedures, as defined in Technical Provision 7.1. Signed original documents shall be forwarded to the Mobility Authority with a transmittal form.
- Advise the property owners, lessee, licensees, occupants, and other holders of compensable interests, as applicable, of the administrative settlement process. Confer with and transmit to the Mobility Authority any settlement request from property owners, lessees, licensees, occupants, or other holders of any compensable interest, as applicable, including a detailed recommendation from the DB Contractor in accordance with standards, manuals and procedures as defined in Technical Provision 7.1. The DB Contractor shall at all times be clear in its dealings with property owners and other holders of compensable interests that the Mobility Authority shall have ultimate decision authority with regard to any settlement requests. Delivery of the administrative settlement request and the DB Contractor's recommendation to the Mobility Authority must occur within 5 Business Days of receipt.
- If requested by the Mobility Authority, participate in the evaluation of the settlement request and attend required meetings. The DB Contractor shall provide a letter of response to the property owner, lessee, licensee, occupant, or other holder of a compensable interest, as applicable. The DB Contractor shall deliver all settlement responses (if within reasonable proximity of the Project) by hand within 3 Business Days from receipt. If this delivery method

is not feasible, the DB Contractor shall mail (return receipt requested) response letters not more than 3 Business Days following any decision by the Mobility Authority. If the DB Contractor uses the mailing option, a follow up call to the property owner will be required to discuss the settlement offer prior to mailing.

- Subject to the Mobility Authority’s prior written approval, prepare and deliver a final offer letter to the property owners, lessees, licensees, occupants, or other holders of any compensable interest, as applicable. The letter shall be on the DB Contractor’s designed right of way letterhead and shall be signed by the DB Contractor’s representative. The DB Contractor shall send the final offer letter no sooner than 30 days after the property owner receives the initial offer letter. The final offer letter shall contain a completed copy of the documents necessary to convey the property to the entity.
- Prepare and deliver documents of conveyance (including bisection clause and access clause, if applicable) to the property owner, lessee, licensee, occupant, or other holder of any compensable interest, as applicable, and obtain their execution of the same. All signatures on documents to be recorded shall be notarized in accordance with Texas Law.
- Appear or provide for the appearance of expert witness(es) or fact witness(es) when requested by the Mobility Authority. The appearances may include pre-commissioner’s hearing preparations, special commissioner’s hearings, and subsequent proceedings.
- Pursue and obtain Right of Possession and Use Agreements concurrently with the parcel negotiations. The form of Right of Possession and Use Agreements will contain provisions allowing for construction to commence while negotiations are finalized. Such agreements will be sought and negotiated by the DB Contractor strictly in accordance with the Law.

7.4.1.6 Closing Services

For purposes of closing services with respect to DB Contractor-Designated ROW, the DB Contractor shall:

- Prepare a request for funding in accordance with TxDOT *Right of Way Manual Volume II*, “Payment Procedures for Negotiated Parcels” or as directed.
- Prepare escrow agreement and closing documents, including a closing memorandum identifying all parties involved in the closing, and listing all documents to be executed and/or delivered in connection with the closing.
- Attend closings; provide curative documents and exhibits as required and in conjunction with the applicable title company. Confirm that all conditions to closing are satisfied and notify the Mobility Authority of all closing appointments.
- Coordinate with the Mobility Authority and applicable title company to obtain updated title commitment prior to closing and then obtain an issued title policy based on the approved

updated title commitment within 30 Days following closing and transmit the same to the Mobility Authority.

- Obtain and deliver two certified copies of each instrument of conveyance to the Mobility Authority immediately after closing, and obtain and deliver the recorded original to the Mobility Authority within 10 Business Days thereafter, and provide to the Mobility Authority a closing binder, including the closing memorandum and an original and two copies of all documents identified in the closing memorandum, within 30 Days following closing.

7.4.1.7 Relocation Assistance

Relocation assistance with respect to the DB Contractor-Designated ROW shall be provided strictly in accordance with the Law, and, in particular, the Uniform Act and standards. With respect to relocation assistance, the DB Contractor shall:

- Provide written notice to all property owners, lessees, licensees, occupants, other holders of compensable interests, and other potential displacees regarding relocation assistance and provide them with a relocation assistance brochure. The DB Contractor shall perform relocation interviews, complete and maintain interview forms and discuss general eligibility requirements, programs, and services with potential displacees. The DB Contractor shall produce relocation assistance brochures as specified above (English and Spanish versions). The DB Contractor shall maintain a written record of all verbal contacts.
- Direct any questions as to the eligibility of a potential displacee in writing to the Mobility Authority.
- Contact and provide relocation assistance to those parties affected by the Final ROW acquisition and complete appropriate forms for all displacees, as required.
- Locate, evaluate and maintain files on comparable available housing, commercial, retail, and industrial sites.
- Calculate replacement supplement benefits.
- Compute and submit requests for relocation rental/housing supplement to the Mobility Authority on appropriate forms. All relocation supplements shall be subject to Mobility Authority approval.
- Perform a “decent, safe, and sanitary” inspection for each replacement housing comparable. Prepare and complete appropriate forms.
- Request typically two or three moving estimates from moving companies to effect relocation of personal property.
- Prepare moving plan with appropriate photos, sketches and inventory of personal property to be moved.

- Coordinate moves with displacees and moving companies in accordance with standards found in the Uniform Act.
- Maintain relocation contact logs on a form and format approved by the Mobility Authority.
- Attend all closings on replacement properties, if requested by any party involved, and assure supplemental payments, if any, are properly distributed.
- Process and compute increased interest payments on the mortgage of owner-occupied dwellings, as required.
- Deliver to displacees a 90-day notice of eligibility letter simultaneous with the delivery of the relocation benefits package. Deliver a 90 day letter to displacees with the location of the comparable property used to compute the supplement.
- Deliver a 30-day notice to displacees upon acquisition of Final ROW, as applicable.
- Notify the Mobility Authority immediately if a displacee has not moved after the 30-day notice expires. Prepare a written recommendation to facilitate the displacee’s move.
- Be available for any appeals or hearings.
- Prepare relocation payment claim submissions for all displacees and all relocation assistance benefits.
- Verify “decent, safe, and sanitary” criteria on all replacement housing as selected by the displacees.
- Secure dwellings and structures no later than 2 Business Days from vacancy and protect the Final ROW following acquisition and relocation.
- Maintain a complete file, separate from acquisition files, on each displacee.
- If a parcel referred to the Mobility Authority for eminent domain also has a relocation issue, the DB Contractor shall be responsible for all relocation activities that may occur after deposit of the Special Commissioner’s Award in the courts.
- All correspondence to the displacees or their representative(s) will be prepared on the DB Contractor’s designated relocation letterhead and will be signed by the DB Contractor’s representative.
- Deliver to each displacee the relocation assistance payments.

7.4.1.8 *Condemnation Support*

With respect to the DB Contractor-Designated ROW, the DB Contractor shall:

- Notify the Mobility Authority of any potential condemnation and document the reason(s) for condemnation including recommendations for property closure.

- Conduct all eminent domain-condemnation activities in accordance with the policies and procedures as described in the TxDOT *Right of Way Acquisition Procedures, Chapter IV: “Eminent Domain”*; in the TxDOT *Appraisal and Review Manual, Chapter 6 “Eminent Domain-State Acquisition”* or as revised; and in *Chapter 21, Texas Property Code*.
- After non-response (minimum of 14 Days) or upon receipt of a copy of the rejected final offer from a property owner or other property right holder entitled to compensation, request an updated title report from the title company issuing the original title commitment.
- Provide, to the Mobility Authority, a signed and sealed parcel description and parcel plat, prepare a bisection clause and access clause, if necessary, and attach the clauses to a property exhibit containing the parcel description and parcel plat.
- Prepare a packet containing two copies each of the following documents: appropriate forms, negotiation logs, the updated litigation guaranty, negotiator’s reports, appraisal receipt acknowledgment, pre-appraisal contact sheet, signed and sealed field notes, parcel sketch, title report, bisection clause and access clause exhibits (if necessary), final offer letter, minute order, any correspondence sent by the DB Contractor or from the owner of the compensable interest or representatives, and one copy of the appraisal report. Submit two complete packets to the Mobility Authority. All information should be current and no older than 90 days.
- Send a copy of the complete petition to the title company and confirm with the title company that the appropriate parties were joined in the case and that no changes in title have occurred since the original litigation guaranty was issued.
- Coordinate and provide legal and technical support to the Mobility Authority’s condemnation attorney, or the Mobility Authority’s counsel as required to facilitate filing the petition, assignment of a court, and setting of a hearing date.
- Make available to the Mobility Authority condemnation attorney an agent who will be expected to assist in making arrangements for conferences with witnesses prior to trial, filing the plaintiff’s statement, informing the condemnation attorney’s office as to the filing date of the statement and the cause number assigned to the suit, and perform any other duties which will assist in the successful prosecution of the suit, including his or her attendance in court and filing necessary documents to complete all eminent domain proceedings.
- The DB Contractor may be required to file documents at the appropriate County office in conjunction with the eminent domain action.
- Depending on the market conditions or if over 6 months have elapsed since date of the initial offer, contact the attorney handling the case for the Mobility Authority and confer about the advisability of preparing an updated appraisal. If it is determined that an updated or new appraisal is determined to be necessary or desirable, obtain such appraisal using the same procedures as described in *Technical Provision 7.4.1.2* above. The DB Contractor must also undertake appraisal review as described in *Technical Provision 7.4.1.3*.

- Submit the updated appraisal to the Mobility Authority and the attorney handling the case for the Mobility Authority. The Mobility Authority must approve any revised offer. If a revised offer is approved by the Mobility Authority, prepare a final offer letter, make the revised offer to the property owner or other holder of a compensable interest, as applicable, and submit a copy of the final offer letter to the Mobility Authority.
- Communicate with the Mobility Authority as to the parcel status on a monthly basis.
- Serve in person, a “Notice of Hearing” at least 20 days prior to the date of hearings as directed by the special commissioners or the court.
- Call and send a reminder letter 2 to 3 weeks in advance of any hearing to the assigned attorney, engineer, technical experts, appraiser, the commissioners, court reporter, and the Mobility Authority concerning hearing dates.
- Upon completion of the hearing, prepare appropriate forms and commissioners’ time sheets. Submit forms and commissioners’ time sheets to the Mobility Authority. The DB Contractor shall make payment to all commissioners involved in the hearing and include payment for commissioners as part of general right of way services.
- Coordinate and provide support to the Mobility Authority’s counsel and facilitate distribution of copies of award, prepare request for payment, and file notice of deposit.
- Appear as an expert witness or fact witness as requested. Make any Subcontractors available to appear as an expert witness or fact witness as requested at the commissioners’ hearing or subsequent proceedings.
- Prepare exhibits for hearings as deemed appropriate by the Mobility Authority.
- Provide timely support to the Mobility Authority to prepare for Mobility Authority Board meetings

7.4.1.9 Clearance/Demolition of DB Contractor-Designated ROW

Following acquisition or possession of any parcel of the DB Contractor-Designated ROW, the DB Contractor shall:

- Within 2 Business Days from vacancy of the property, or as soon as practicable, secure and protect the buildings, improvements and fixtures on the DB Contractor-Designated ROW until they are disposed of or demolished. The DB Contractor shall board-up, mow, and winterize as required by the Mobility Authority or applicable Law.
- Coordinate with the owner and occupants to assure the clearance of personal property from the DB Contractor-Designated ROW, as applicable.
- Provide for any insect and rodent control and initiate extermination as required to rid the DB Contractor-Designated ROW, as applicable, from infestations.

- Secure Governmental Approvals required for demolition and environmental surveys or tests (i.e., surveys for asbestos containing materials), and notify the Mobility Authority in writing of all such activities.
- Prepare necessary documentation for disposal of improvements, fixtures and buildings in accordance with applicable Laws and submit the same to the Mobility Authority. All asbestos containing materials shall be disposed of by the DB Contractor outside of the Final ROW in accordance with TxDOT and the Texas Department of State Health Services regulations.
- Provide written notification to the Mobility Authority of any real and/or personal property remaining on the DB Contractor-Designated ROW after vacated by the occupants and not acquired as part of the acquisition.
- Terminate all utility service(s) when appropriate.
- Process all required forms, documents and permit applications in order to proceed with the timely demolition or removal of any and all improvements, buildings and fixtures located within the DB Contractor-Designated ROW, as applicable.
- Perform any and all demolition needed to meet the needs of the Project. Evaluate the performance of demolition Work and provide the Mobility Authority with a summary of findings.
- Areas within the Schematic ROW designated inside the limit of disturbance and as a Designated Preserved Areas shall remain undisturbed.
- Notify the Mobility Authority upon completion of the demolition and clearance of the DB Contractor-Designated ROW, as applicable.
- Maintain records on file of all aspects of the clearance/demolition process.

7.4.1.10 Administration and Management of DB Contractor-Designated ROW

The DB Contractor shall perform administration and management services of the DB Contractor-Designated ROW acquisition services in accordance with the following:

- Maintain parcel records on file of all aspects of the acquisition process for the DB Contractor-Designated ROW in accordance with applicable Law. Each parcel file shall include all documents required by the Contract Documents, FHWA, and/or the Mobility Authority.
- Provide monthly summaries of Project expenses including amounts authorized, amounts paid and budget forecasting on a parcel-by-parcel and overall Project basis as requested by the Mobility Authority.
- Provide budget projections and anticipated funding requirements every 30 days and more frequently as requested by the Mobility Authority.

- Maintain and electronically transmit to the Mobility Authority, in a format acceptable to the Mobility Authority, monthly status reports of all parcels and activities related to the DB Contractor-Designated ROW, additional DB Contractor required properties acquisition and disposition, and acquisition and disposition of temporary easements or other property interests, and provide weekly updates to the Mobility Authority.
- Provide copies of all incoming and outgoing correspondence as requested. All correspondence shall be numbered in accordance with *Technical Provision 1*.
- Evaluate, and report, to the Mobility Authority, Subcontractor status and performance on a monthly basis or more frequently as requested.
- Prepare and submit to the Mobility Authority, on a monthly basis, an electronically or a spreadsheet that contains the DB Contractor-Designated ROW specific data as directed by the Mobility Authority.
- Input and update parcel status in web based tracking system or as directed by the Mobility Authority.

7.4.1.11 Project Monitor/Reviewer

The Mobility Authority or its designee may, at its discretion, review and/or monitor the right of way activities and services performed by the DB Contractor.

The Mobility Authority will notify the DB Contractor in writing of any monitor/reviewer under Contract Documents with the Mobility Authority.

In addition to any of the matters specifically required to be provided by the DB Contractor to the Mobility Authority pursuant to the foregoing sections, the DB Contractor shall provide information to the Mobility Authority as requested to assist in its review and assessment of the progress, timeliness, adequacy, or sufficiency of the DB Contractor's right of way activities.

7.5 Mobility Authority Responsibilities

The Mobility Authority will:

- Coordinate the acquisition of all Schematic ROW including mapping, appraisal, negotiation, clearing and title, and closing of acquisitions.
- Compensate or cause third parties to compensate landowners directly for the final negotiated land cost associated with the final property acquisition of Schematic ROW.
- For each parcel of the Final ROW (excluding the DB Contractor's Designated ROW or temporary easements needed for construction), process and issue all approved warrants for payment of agreed purchase prices or awards, and relocation assistance payments involved in the transfer of Final ROW to the Mobility Authority in accordance with applicable Law.

- Pay the cost of and be responsible for processing and issuing all payments of agreed purchase prices or awards and relocation assistance payments, related to the Schematic ROW.
- Provide final approval of all title reports, appraisals, relocation assistance payments, administrative settlement requests, payments, and other approvals required by applicable Law.
- Coordinate with Mobility Authority Legal Counsel to file and prosecute condemnation hearings.

Temporary Easements. The Mobility Authority will not be responsible for, nor will it participate in obtaining, any temporary easements for construction staging areas or material storage areas that are deemed necessary by the DB Contractor but are outside the Final ROW.

7.6 Submittals

Table 7-1: Submittals to Mobility Authority

Submittals	Submittal Schedule	Department Action	Reference Section
TxDOT Introduction letter and Landowner Bill of Rights to Property Owners and Displacees	Prior to commencing right of way acquisition of specific parcels	Approval and signature	7.4.1
Five-year sales history, a preliminary title commitment or preliminary title report, copies of all underlying documents and a plot of all easements, including Existing Utility Property Interests, referenced therein for each parcel	As part of the Acquisition Package	Information	7.4.1.1
Appraisal Reports	Prior to submission of the first Acquisition Package, and as requested	Approval	7.4.1.2
Property Classification Agreement	As part of the Appraisal Report	Information	7.4.1.2
Acquisition Packages	Prior to delivering the offer to each property owner	Approval	7.4.1.4
Project ROW map	Part of the Acquisition Survey Document	Approval	7.4.1.4
Acquisition Survey Document	As part of any Acquisition Package	Approval	7.4.1.4
Relocation Plan	As part of the respective parcel's Acquisition Package or separately	Approval prior to commencement of Construction Work	7.4.1.4
Administrative Settlement Submittals	As necessary	Approval	7.4.1.5

Table 7-1: Submittals to Mobility Authority

Submittals	Submittal Schedule	Department Action	Reference Section
Completed closeout files	Within 30 days of the completed ROW parcel activity	Approval	7.4.1.6
Request for relocation Rental/Housing	As needed	Approval	7.4.1.7
Condemnation Packages	As needed	Approval	7.4.1.8
Cost Summaries	Monthly	Approval	7.4.1.10
Status Reports	Monthly	Approval	7.4.1.10
Status Updates	Weekly or as requested	Information	7.4.1.10
ROW data collection system	Monthly	Approval	7.4.1.10

8.0 UTILITIES

8.1 General Requirements

A number of existing Utilities are located within or in the vicinity of the Schematic ROW, some pursuant to statutory rights and some pursuant to property rights. Certain of these existing Utilities will need to be relocated or otherwise adjusted in order to accommodate the Project.

This *Technical Provision 8* establishes procedures and requirements for Adjusting Utilities including such processes as coordination with Utility Owners, administration of engineering, construction and other activities necessary for Utility Adjustments, and required documentation.

The DB Contractor shall be responsible for Utility Work in accordance with the requirements identified in this *Technical Provision 8*.

The DB Contractor's Work shall include coordination, design, design review, permitting, construction, construction inspection, maintenance of records, easement acquisition, coordination, and any other Utility Adjustment Work as shall be required to complete the Work as described within the Contract Documents. The term "Adjustment" includes each reinstallation in a new location, adjustment, reconstruction, adjustment-to-grade, restoration, provision of temporary services as required, maintenance, support and protection-in-place (whether permanent or temporary), removal, and/or abandonment (in accordance with procedures identified in this *Technical Provision 8*) of existing Utilities as necessary to accommodate or permit construction of the Project improvements (or as may be determined by the DB Contractor to be required for its construction activity).

The DB Contractor shall be responsible for Incidental Utility Adjustment Work, which has the meaning set forth in the DB Contract.

The DB Contractor shall ensure that the design and construction of all Utility Adjustments are compatible with the Project Design and that all such Utilities are compatible with and interface properly with the Project. For additional requirements, see this *Technical Provision 8*.

The DB Contractor is responsible for coordination, identification of existing utilities, field investigations, design, design review and approval, securing any necessary local or municipal permits required for City of Austin adjustments, permitting, review of TxDOT utility permit applications, construction, construction inspection, maintenance of records, utility as-builts, easement acquisitions, relinquishing property interests and management, and preparation and execution of utility agreements.

Notwithstanding any preliminary Utility coordination activities performed by TxDOT or the Mobility Authority prior to the effective date of the DB Agreement, the DB Contractor shall assume full and complete responsibility for all Utility Adjustments in accordance with the Contract Documents, and shall not be

entitled to any Change Order with respect to any Utility Adjustment Work, except as otherwise specified in the Contract Documents.

The DB Contractor shall use the Mobility Authority's standard Utility forms for all Utility Adjustment Work. The standard Utility forms are included in Exhibit D – Item 4 – Utilities (Standard Utility Forms). Revisions to the standard Utility forms must be approved by the Mobility Authority.

The DB Contractor shall cause all Utility Adjustments necessary to accommodate construction, operation, maintenance and/or use of the Project. The Mobility Authority will assist the DB Contractor in the Utility Adjustment process, to the extent described in the Contract Documents. Some Utility Adjustments may be performed by the Utility Owner with its own forces and/or contractors and consultants (i.e., owner-managed); all others shall be performed by the DB Contractor with its own forces and/or Contractors and consultants (subject to any approval rights required by the Utility Owner for those working on its facilities) (i.e., DB Contractor-managed). The allocation of responsibility for the Utility Adjustment Work between the DB Contractor and the Utility Owners shall be specified in the Utility Agreements.

The physical limits of Utility Adjustments shall extend as far as is necessary (taking into account the requirements of the Utility Owners and applicable Laws) to accommodate the construction of the Project whether inside or outside of the Final ROW. In the case of telecommunications, the foregoing may require not only Adjustment of the portion of the facility affected by Project construction, but also extension of such Adjustment to the facility's nearest splice point, if required by the Utility Owner in order to maintain its standards.

The DB Contractor's obligations regarding reimbursement to Utility Owners for eligible costs of Utility Adjustment Work are set forth in the Utility Agreements.

This Technical Provision 8 does not address Utility services to the Project. Utility services to the Project shall be the subject of separate agreements between the DB Contractor and Utility Owners.

8.2 Referenced Standards and Guidelines

All Utility Adjustment Work (whether performed by the DB Contractor or by the Utility Owner) shall comply with all applicable Texas Law, federal regulations, all other applicable Laws, the policies of the Mobility Authority, and all requirements of the Contract Documents including;

- Texas Administrative Code
- TxDOT ROW Utility Manual
- Utility Owners' appropriate standards
- TxDOT Standard Specifications for Construction and Maintenance of Highways, Streets, and Bridges, adopted by TxDOT in November 2014
- Texas Manual on Uniform Traffic Control Devices (TMUTCD)

- TxDOT Standards
- 43 TAC 21.31–21.56 (commonly called the TxDOT Utility Accommodation Rules)
- City Of Austin Utilities Criteria Manual (UCM)
- TCEQ Edwards Aquifer Rules (30 TAC 213)

8.3 Information Provided by the Mobility Authority

The Mobility Authority performed a subsurface utility engineering (SUE) investigation within and near the Schematic ROW. The investigation results are provided in the Existing Utility Information in Exhibit D – Item 4 – Utilities. This Existing Utility Information provides, to the extent reasonably known to the Mobility Authority, ownership, approximate location and type.

Notwithstanding any preliminary utility coordination activities performed by TxDOT or the Mobility Authority prior to the effective date of the DB Contract, the DB Contractor shall assume full and complete responsibility for all Utility Adjustments in accordance with the Contract Documents, and shall not be entitled to any Change Order with respect to any Utility Adjustment Work, except as otherwise specified in the Contract Documents.

Preliminary City of Austin Water and Wastewater Plans and Utility Criteria Manual and Related Design Documents prepared by the City of Austin Public Works Department are included in Exhibit D – Item 4 – Utilities (Existing Utilities Information).

Acknowledgment. the Existing Utility Information does not identify Existing Utility Property Interests or individual property service lines within or adjacent to the Project limits, and may not identify all other Utilities within or adjacent to the Project limits. It is the DB Contractor’s responsibility to coordinate the property services lines, all applicable fees and any additional requirements to restore service to the individual property owners.

Disclaimer. The Existing Utility Information may not show the Utilities at their correct locations. All station numbers used for such purpose are approximate and the size, ownership, number of lines, type of Utility, or other characteristics may not be correct.

8.4 General Description of Work

DB Contractor Responsibilities. The DB Contractor shall perform or cause to be performed all Utility Adjustment Work necessary for the Project, without regard to any of the following:

- Whether or not the Utility and/or the necessity of the Work was identified before the Proposal Date.
- Any prior discussions TxDOT and/or the Mobility Authority have had with Utility Owners regarding Utility Adjustment Work.

- Whether or not such Utility was indicated or indicated accurately in Exhibit D – Item 4 – Utilities (Existing Utility Information).
- The extent of the Work necessary to adjust such Utility.

Who Does the Work. The DB Contractor shall either:

- Perform all necessary Utility Adjustment Work with its own forces and/or subcontractors and subconsultants, or
- Cause the Utility Adjustment Work to be performed by the Utility Owner with its own forces, its contractors, and/or its consultants.

Approval of Locations. Any Utility reinstalled in a new location or adjustment in any manner within the Final ROW shall be installed in a location as proposed by the DB Contractor, based on coordination with all affected parties and subject to approval by the Mobility Authority. Utilities will not be permitted to be relocated to easements within the Edwards Aquifer. With written approval by the Mobility Authority and the Utility Owner, Utilities may remain in their existing location if, approved by the Utility Owner and the Mobility Authority, the requirements of the UAR are met, the location will not adversely affect the Project, the future operation of the Project, the Project Design, or the safety of the traveling public. Existing utilities crossing the ROW at an angle may remain in place if the utility is not in conflict or only requires extension of the casing.

8.5 Utility Adjustment Team

The DB Contractor shall provide a Utility Adjustment team with appropriate qualifications and experience to perform the Utility Adjustment Work. The DB Contractor shall provide the names and contact details, titles, job roles, and specific experience of the team members in the PMP. Specifically, the DB Contractor shall provide a Utility Manager (UM) and a Civil/Utility Engineer (CUE) as described herein.

Utility Manager. The UM’s primary Work responsibility shall be the performance of all of the DB Contractor’s obligations with respect to the Utility Adjustment Work. The UM shall have a Bachelor’s degree, and have a minimum of 4 years of relevant work experience in coordinating and solving complex utility adjustments on highway improvement projects.

Civil/Utility Engineer. The DB Contractor shall designate a CUE to be responsible for coordinating the Utility Adjustment design with the overall Project Design in accordance with the requirements of this Technical Provision 8 during the planning, design, and construction phases of the Work. The CUE shall also provide technical expertise in Utility coordination and ensure that all utility relocations follow the UAR, TxDOT Utility Manual and any standards or specifications set forth by the utility companies.

The CUE shall be a Registered Professional Engineer and have relevant experience in coordinating and solving complex utility adjustments on highway projects. The CUE should be knowledgeable as to the requirements of the UAR and TxDOT's Utility Manual.

8.6 Coordination and Cooperation with Utilities

8.6.1 DB Contractor Role

DB Contractor Responsibilities. The DB Contractor shall be responsible for all coordination with each affected Utility Owner that is necessary and appropriate to accomplish the Utility Adjustment Work.

Scheduling Notice. The DB Contractor shall keep each Utility Owner well informed of the DB Contractor's construction schedules and of changes that affect its Utility facilities, and give each Utility Owner sufficient time to notify its customers of any potential impacts on service.

Cooperation and Partnering. The DB Contractor shall cooperate with Utility Owners to the extent that such cooperation is consistent with the DB Contractor's obligations pursuant to the Contract Documents and the scope of the Project. The DB Contractor shall act diligently in maintaining positive relationships with the Utility Owners.

8.6.2 Failure of Utility to Cooperate

Notice to The Mobility Authority. The DB Contractor shall use its best efforts to obtain the cooperation of each Utility Owner as necessary for the Project. In the event of any dispute with a Utility Owner or non-cooperation by a Utility Owner, the DB Contractor shall comply with the provisions of Section 14.12.5 of the DBA.

8.7 Meetings and Correspondence

8.7.1 Meetings with Utility Owners

Periodic Meetings. The DB Contractor shall implement a schedule of periodic meetings with each Utility Owner's representative for coordination purposes. Such meetings shall begin as early as possible in the design process and shall continue until completion of the Utility Owner's acceptance of Adjustments. The frequency of such meetings shall be appropriate to the matters under discussion with each Utility Owner. The DB Contractor shall provide an opportunity for the Mobility Authority to participate in such meetings and shall notify the Mobility Authority at least 3 Business Days in advance of each scheduled meeting. The DB Contractor shall provide notice and an agenda for the meeting to the Mobility Authority.

The DB Contractor shall prepare minutes of each meeting with representatives of a Utility Owner and/or the Mobility Authority, and shall distribute the minutes to the Utility Owner and the Mobility Authority no later than 5 Business Days after each meeting date. The DB Contractor shall provide to the Mobility

Authority copies of all correspondence between the DB Contractor and any Utility Owner no later than 5 Business Days after receipt or sending, as applicable.

8.7.2 Meetings Between Mobility Authority and DB Contractor

Requested Meetings. Representatives of the Mobility Authority and the DB Contractor (including the CUE and other appropriate staff) shall be available to meet at the request of the other Party as necessary to discuss and resolve matters relating to the Utility Adjustment Work, including schedules, design changes, Utility identification, and negotiations with Utility Owners. The DB Contractor shall schedule such meetings and shall provide the Mobility Authority with prior notice of at least 5 Business Days.

8.8 Verification of Utility Locations

8.8.1 DB Contractor’s Responsibility

Sole Responsibility. The DB Contractor bears sole responsibility for ascertaining the exact location, size, type, and all other relevant characteristics of all Utilities in the Final ROW or otherwise affected by the Project, whether located on private property or within an existing public ROW, including all service lines. The DB Contractor’s obligation shall include making diligent inquiries at the offices of the Utility Owners, consulting public records, and conducting Subsurface Utility Engineering (SUE), including field studies (such as potholing), as appropriate. The DB Contractor shall take into consideration the possibility that the information provided by the Mobility Authority may be inaccurate, and that the Utility Owners may also have provided to the DB Contractor inaccurate or inexact information about their facilities.

Field Verification. Accurate field verification of some Utilities may be required to design Project features to avoid conflicts, to adjust the utility, or to conclude that neither action is necessary. The extent of information needed and the information provided for each Utility facility will be decided by mutual agreement between the DB Contractor and the Utility Owner. Field verification information shall be supplied, both horizontally and vertically, in the Project control datum to accurately apply the locations to the Project drawings and databases.

The DB Contractor shall prepare and submit to the Mobility Authority, no later than 30 days before the first assembly package is submitted, a Utility Strip Map showing the information obtained and/or confirmed pursuant to this Technical Provision 8.8.1. The DB Contractor’s Utility Strip Map shall show in “plan view” all of the Utilities within the Final ROW or otherwise impacted by the Project, in each case detailing the type of Utility facility (communication, gas, oil, water, etc.) and the Utility Owner’s name and contact information. The scale of the Utility Strip Map shall be 1 inch – 200 feet.

8.8.2 Notification as to Newly Identified Utilities

If the DB Contractor’s investigations identify any unidentified Utility, the DB Contractor shall notify the Mobility Authority immediately upon such discovery.

8.8.3 Utility Tracking Report

The DB Contractor shall maintain a Utility Tracking Report in tabular form that lists all Utilities located within the Final ROW or otherwise potentially affected by the Project. The Utility Tracking Report shall be maintained current at all times and shall be submitted to the Mobility Authority monthly. The Utility Tracking Report shall contain the following information for each Utility listed thereon:

- The name of the Utility Owner and a unique identification number for tracking.
- A brief description of the Utility by size and type.
- The location of the Utility, based upon Project control datum or by station and offset.
- The proposed treatment of the Utility (e.g., protection in place or reinstallation in a new location) and (if the Utility is to remain in its original location) the date such treatment was approved by the Mobility Authority.
- Identify any Utility Betterments, and the Party (the DB Contractor or the Utility Owner) responsible for funding the Utility Adjustment and performing the Work.
- Dates on which the Utility Agreement was executed by: Utility Owner, DB Contractor, and Mobility Authority.
- Whether any New Utility Property Interest will be necessary for the Adjustment.
- The nature of the Utility Owner's existing right of occupancy of the ROW for such Utility (e.g., Utility Joint Use Acknowledgement, permit, notice, easement, or a combination of these).
- The scheduled start and completion dates of construction of each Utility Adjustment.
- The actual start and completion dates of construction of each Utility Adjustment.
- The status of construction for each Utility Adjustment, including percentage complete.

Updating and Sorting. The first Utility Tracking Report shall identify all changes from and additions to the information provided by the Mobility Authority. Each subsequent version of the report shall identify all changes from the previous version.

8.9 Administrative Requirements

8.9.1 Standards

All Utility Adjustment Work shall comply with all applicable Laws, the Technical Documents, the Utility Owner Standards/Specifications and the requirements specified in this *Technical Provision 8*.

8.9.2 Real Property Matters

The DB Contractor shall provide the services described below in connection with existing and future occupancy of property by Utilities.

8.9.2.1 *Documentation of Existing Utility Property Interests – Affidavits*

For each Existing Utility Property Interest within the Project ROW claimed by any Utility Owner, the DB Contractor shall include an affidavit of property interest in the applicable Utility Assembly, with documentation of the Existing Utility Property Interest (e.g., an easement deed) attached. Any such claim shall be subject to Mobility Authority's review as part of its Utility Assembly review. Except as otherwise directed by the Mobility Authority, the DB Contractor shall prepare all Affidavits of Property Interest using the standard forms.

8.9.2.2 *Acquisition of New Utility Property Interests*

The DB Contractor will be responsible for acquiring any New Utility Property Interests that are necessary for its Utility Adjustments.

The files and records must be kept separate and apart from all acquisition files and records for the Final ROW.

The items used in acquisition of New Utility Property Interests (e.g., appraisals, written evaluations and owner contact reports) must be separate from the purchase of the Final ROW. Any DB Contractor Group staffers negotiating the acquisition of New Utility Property Interests must be different from those negotiating the acquisition of Final ROW.

The DB Contractor is responsible for preparation of all documentation for Utility Owner condemnation proceedings. The Utility Owner will be responsible for prosecuting such condemnations.

8.9.2.3 *Relinquishment of Existing Utility Property Interests*

The DB Contractor shall cause the affected Utility Owner to relinquish each Existing Utility Property Interest within the Final ROW, unless the existing Utility occupying such interest is either (i) remaining in its original location, or (ii) being reinstalled in a new location still subject to such interest.

8.9.2.4 *Quitclaim Deeds*

Except as otherwise directed by the Mobility Authority, the DB Contractor shall prepare a Quitclaim Deed for each relinquishment of an Existing Utility Property Interest using the Mobility Authority's standard form. Each Quitclaim Deed shall be subject to the Mobility Authority's review as part of a Utility Assembly as described below.

The DB Contractor understands and expects that a Utility Owner will not relinquish any Existing Utility Property Interest until after the Adjusted Utility has been accepted by the Utility Owner in its new location. Accordingly, instead of an executed Quitclaim Deed, the Utility Assembly for such a Utility Adjustment shall include a letter signed by the Utility Owner's authorized representative confirming that the interest will be quitclaimed upon completion of the Utility Adjustment, and a copy of the unsigned Quitclaim Deed. In these cases, the DB Contractor shall obtain the executed Quitclaim Deed promptly upon completion of the Utility Adjustment.

8.9.2.5 *TxDOT's Online Permit*

The DB Contractor shall successfully obtain a permit through TxDOT's online process for each Utility Adjustment and include the permit with any corresponding Utility Adjustment Agreement to the Mobility Authority. A permit shall be required before commencing the Utility Adjustment.

8.9.2.6 *Documentation Requirements*

The DB Contractor shall prepare, negotiate (to the extent permitted by this *Technical Provision 8.9.2*), and obtain execution by the Utility Owner of (and record in the appropriate jurisdiction, if applicable) all agreements and deeds described in this *Technical Provision 8.9.2*, including all necessary exhibits and information concerning the Project (e.g., reports, plans and surveys). Each agreement or deed shall identify the subject Utility(ies) by the applicable Utility Assembly Number (183N-U [4 digit Number beginning with 0100]), and shall also identify any real property interests by parcel number or highway station number, or by other identification acceptable to the Mobility Authority.

8.10 *Agreements*

8.10.1 *Certain Components of the Utility Adjustment Work*

Coordination. The DB Contractor shall communicate, cooperate, and coordinate with the Mobility Authority, the Utility Owners and potentially affected third parties, as necessary for performance of the Utility Adjustment Work. The DB Contractor shall be responsible for preparing (unless prepared by the Utility Owner) and securing execution (by the DB Contractor and the Utility Owner) of all necessary Utility Agreements. All executed Utility Agreements between the DB Contractor and Utility Owners must be approved by the Mobility Authority prior to taking effect.

Betterments. Replacements for existing Utilities shall be designed and constructed to provide service at least equal to that offered by the existing Utilities, unless the Utility Owner specifies a lesser replacement. Utility Enhancements are not included in the Work; however, any Betterment Work furnished or performed by the DB Contractor as part of a Utility Adjustment shall be deemed added to the work, on the date the Utility Agreement providing for same becomes fully effective. The DB Contractor shall perform all coordination necessary for Betterments.

Protection in Place. The DB Contractor shall be responsible for Protection in Place of all Utilities impacted by the Project as necessary for their continued safe operation and structural integrity and to otherwise satisfy the requirements described in *Technical Provision 8.9.1.*

Abandonment and Removal. The DB Contractor shall make all arrangements and perform all Work necessary to complete each abandonment or removal (and disposal) of a Utility in accordance with the requirements listed in *Technical Provision 8.2,* including obtaining Governmental Approvals and consent from the affected Utility Owner and any affected landowner(s) (or shall confirm that the Utility Owner has completed these tasks). Existing abandoned Utilities encountered during DB Contractors Work shall be evaluated on a case by case basis to determine the need for any additional treatment such as grouting, removal, or plugging. Treatment approach shall be approved by the Mobility Authority.

For any asbestos cement (“AC”) pipe removal work, the DB Contractor shall follow the requirements listed in *Technical Provision 8.2* as well as the City of Austin’s established procedures and requirements. In the event of any contamination caused by the pipeline removal, the DB Contractor shall be responsible for that remediation.

With the exception of undisturbed AC pipe as approved to remain in place, no facilities containing hazardous or contaminated materials may be abandoned, but shall be specifically identified and removed in accordance with the requirements listed in *Technical Provision 8.2.*

Service Lines and Utility Appurtenances. Whenever required to accommodate construction, operation, maintenance and/or use of the Project, the DB Contractor shall cause Service Line adjustments and Utility Appurtenance Adjustments. On completion of these, the DB Contractor shall cause full reinstatement of the roadway, including reconstruction of curb, gutter, sidewalks, and landscaping, whether the Utility Adjustment Work is performed by the Utility Owner or by the DB Contractor. The DB Contractor is responsible for acquiring easements required for service lines, meters, and appurtenances. Existing above ground appurtenances such as fire hydrants and blow-off valves shall not be allowed to remain within the proposed sidewalk. Manholes and valves may remain in place under proposed sidewalks, however, all manhole and valve covers shall be installed flush with the sidewalk pavement.

Early Utility Adjustments. The Mobility Authority may coordinate the design and adjustment of certain Utilities in advance of NTP 1 issuance. The Mobility Authority makes no guarantees for any resulting plans and subsequently, the DB Contractor will assume all responsibility associated with the use of resulting plans including but not limited to completion, modification, obtaining any and all approvals and for ensuring compliance with *Technical Provision 8.11.*

8.10.2 Agreements Between DB Contractor and Utility Owners

Except as otherwise stated in this *Technical Provision 8* or in the DBA, each Utility Adjustment shall be specifically addressed in a Master Utility Adjustment Agreement (MUAA) or in a Utility Adjustment Agreement Amendment (UAAA). The DB Contractor is responsible for preparing, negotiating (to the

extent allowed by this *Technical Provision 8*), and obtaining execution by the Utility Owners, of all Utility agreements, (including preparing all necessary exhibits and information about the Project such as reports, plans and surveys). A Utility agreement is not required for any Utility Adjustment consisting solely of Protection in Place in the Utility's original location within the Final ROW, unless the Utility Owner is being reimbursed for costs incurred by it on account of such Protection in Place.

8.10.3 Master Utility Adjustment Agreements

The DB Contractor shall enter into one or more MUAAs with each affected Utility Owner to define the design, material, construction, inspection, and acceptance standards and procedures necessary to complete Utility Adjustments, as well as to define the DB Contractor's and the Utility Owner's respective responsibilities for Utility Adjustment costs and Utility Adjustment activities such as material procurement, construction, inspection and acceptance. A MUAA may address more than one Utility Adjustment for the same Utility Owner. Additional Adjustments may be added to an existing MUAA by an UAAA.

The DB Contractor shall prepare each MUAA using the Mobility Authority's standard form for the MUAA (Owner-Managed) or the Mobility Authority Master Utility Adjustment Agreement (DB Contractor-Managed).

Promptly following issuance of NTP1, the DB Contractor shall begin negotiations with each affected Utility Owner to reach agreement on one or more MUAAs. The DB Contractor shall use good faith efforts to finalize a MUAA with each affected Utility Owner within a reasonable time period after issuance of NTP1. The DB Contractor shall include any proposed changes to a standard form (other than filling in blanks that are specific to a particular Utility Owner) in a Utility Owner-specific addendum. Each MUAA (including the Utility Adjustment Plans attached thereto) shall be subject to Mobility Authority approval as part of a Utility Assembly.

8.10.4 Utility Adjustment Agreement Amendments

Except where informal modification is permitted pursuant to *Technical Provision 8.12.6*, modification of an executed MUAA or any component thereof, after it has been approved by the Mobility Authority as part of a Utility Assembly, shall be stated in an UAAA. An UAAA may be used only when the allocation of responsibility for the Utility Adjustment Work covered by that UAAA is the same as in the underlying MUAA; otherwise, an additional MUAA will be required.

Each UAAA (including any Utility Adjustment Plans attached thereto) shall be subject to the Mobility Authority's approval as part of a Supplemental Utility Assembly. Except as otherwise directed by the Mobility Authority or provided in an applicable MUAA, the DB Contractor shall prepare all UAAAs using the standard form provided.

8.11 Design Requirements

8.11.1 General Design Criteria

All design plans for Utility Adjustment Work, whether furnished by the DB Contractor or by the Utility Owner, shall be consistent and compatible with the following:

- The applicable requirements of the Contract Documents.
- The Project as designed and constructed.
- Any other Utilities being installed in the same vicinity.
- All applicable Governmental Approvals.
- Private approvals of any third parties necessary for such Work proposed.

The DB Contractor shall prepare a conceptual Utility design (a Utility Adjustment Concept Plan) for the Project showing the approximate location of each existing Utility, the existing Utilities to remain, and the DB Contractor's Utility Adjustment recommendation. The DB Contractor shall submit the plan to the Mobility Authority. The Utility Adjustment Concept Plan shall be submitted in both tabular and plan formats. The plan shall be color-coded and shall utilize a scale that clearly depicts all of the required information. The DB Contractor shall coordinate with the affected Utility Owners as necessary to obtain their respective concurrence with the Utility Adjustment Concept Plan as initially submitted to the Mobility Authority and with any subsequent revisions.

8.11.2 Utility Adjustment Plans

Utility Adjustment Plans, whether furnished by the DB Contractor or by the Utility Owner, shall be signed and sealed by a Registered Professional Engineer.

8.11.3 Plans Prepared by the DB Contractor

Where the DB Contractor and the Utility Owner have agreed that the DB Contractor will furnish a Utility Adjustment design, the DB Contractor shall prepare and obtain the Utility Owner's approval of plans, specifications, and cost estimates for the Utility Adjustment (collectively, "Utility Adjustment Plans") by having an authorized representative of the Utility Owner sign the plans as "reviewed and approved for construction." The Utility Adjustment Plans (as approved by the Utility Owner) shall be attached to the applicable Utility Agreement, which the DB Contractor shall include in the appropriate Utility Assembly for the Mobility Authority's approval. All Utility Adjustment Plans must be signed and sealed by a Registered Professional Engineer.

Unless otherwise specified in the applicable Utility Agreement(s), all changes to Utility Adjustment Plans previously approved by the Utility Owner (excluding estimates, if the Utility Owner is not responsible for any costs) shall require written Utility Owner approval. The DB Contractor shall transmit any Mobility

Authority comments to the Utility Owner, and shall coordinate any modification, approval by the Utility Owner and resubmittal to the Mobility Authority as necessary to obtain the Mobility Authority's approval.

8.11.4 Plans Prepared by the Utility Owner

For all Utility Adjustment Plans to be furnished by a Utility Owner, the DB Contractor shall coordinate with the Utility Owner as necessary to confirm compliance with the applicable requirements. Those Utility Adjustment Plans shall be attached to the applicable Utility Agreement, which the DB Contractor shall include in the appropriate Utility Assembly for Mobility Authority's approval. The DB Contractor shall transmit any Mobility Authority comments to the Utility Owner, and shall coordinate any modification, review by the DB Contractor and resubmittal to the Mobility Authority as necessary to obtain the Mobility Authority's approval.

8.11.5 Design Documents

Each proposed Utility Adjustment shall be shown in plan and profile in the Design Documents, regardless of whether the Utility Adjustment Plans are prepared by the DB Contractor or by the Utility Owner.

8.11.6 Certain Requirements for Underground Utilities

Casing as specified in the Utility Accommodation Rules shall be used for all underground Utilities crossing the Final ROW. However, high-pressure gas and liquid petroleum pipelines may be allowed to cross the Final ROW without steel casing as long as the requirements of the Utility Accommodation Rules are met. All high-pressure gas pipelines within the Final ROW shall comply with a design factor "F" = 0.6 or less as required by the class location of the pipeline. Casing is required on existing utilities under pavement widening if the utility is already cased under the existing pavement. Casing is required on all new or relocated utilities under new pavement or existing pavement.

8.11.7 Utility Assemblies

Each Utility Adjustment (as well as each Utility remaining in place in the Project ROW and not requiring any Protection in Place or other Utility Adjustment) shall be addressed in a Utility Assembly prepared by the DB Contractor and submitted to the Mobility Authority for its review and comment, and for the Mobility Authority's approval of any items for which this Technical Provision 8 requires Mobility Authority's approval. Each Utility Adjustment shall be addressed in a full Utility Assembly, unless it is appropriate for a Supplemental Utility Assembly or Abbreviated Utility Assembly, as described below. The DB Contractor shall coordinate with the Utility Owner to prepare all components of each Utility Assembly. Completion of the review and comment process for the applicable Utility Assembly, as well as issuance of any required Mobility Authority approvals, shall be required before the start of construction for the affected Utility Adjustment Work.

Provisions governing the procedure for and timing of Utility Assembly submittals are in Technical Provision 8.13.

All Utility Adjustments covered by the same initial MUAA shall be addressed in a single full Utility Assembly, which shall include all items as described below:

- A transmittal memo recommending approval and detailing any unique characteristics or information pertaining to the subject Utility Adjustment(s); the memo also shall briefly explain the need for the Adjustment(s).
- A completed Utility Assembly checklist (using the Mobility Authority's then-standard form for such purpose) including a no conflict sign-off form executed by the DB Contractor's UM and CUE.
- A proposed Utility Agreement which has been executed by the Utility Owner and the DB Contractor (one original in each of the three original Utility Assemblies); required attachments shall be included.
- Utility Adjustment Plans (in paper format) with all information necessary, and in proper format, which:
 - Show plan and profiles of the existing Utility facilities and proposed Adjustments.
 - Show any existing highway ROW lines, the Final ROW lines and control of access lines.
 - Show the proposed roadway features of the Project and other Utilities in the vicinity.
 - Show the final Project grade and any railroad profiles in order to determine whether clearance requirements are met.
 - Show an offset distance from the Final ROW line to the proposed Utility facility, for each Utility which will parallel (and be within) the proposed Final ROW lines (whether proposed to remain in place or be reinstalled in a new location).
 - Show dimensions to Utility facilities with station and offset in relation to the Final ROW line.
 - Show symbols and major material items.
 - Provide the Utility Owner's specifications for the Adjustment.
 - Present sufficient information to enable the Mobility Authority to verify compliance with UAR requirements (including depth of cover, casing requirements, vent locations, etc.).

- Are color coded on at least one of the three original Utility Assemblies for each Utility or group of Utilities.
 - Shall be no larger than 11” x 17” folded to 8.5” x 11” size (oversize plans are not permitted with the Utility Assembly, and plans shall be folded so as to be able to pull the plans out of the assembly, sheet by sheet).
 - Clearly identify Betterments.
 - Are signed and sealed by a Registered Professional Engineer, whether provided by the DB Contractor or the Utility Owner, unless waived at the Mobility Authority’s sole discretion.
- Estimate(s) from the Utility Owner detailing costs within the cost categories established in 23 CFR 645.117.
 - Statement(s) covering construction contract Work (using the Mobility Authority’s then-standard form for such purpose), if the Utility Owner intends to contract out design and/or construction Work.
 - Affidavit(s) of property interest, if required by *Technical Provision 8.9.2.1*.
 - When applicable, a letter signed by the Utility Owner’s authorized representative confirming that the interest will be quitclaimed upon completion of the Utility Adjustment and a copy of the unsigned Quitclaim Deed.

Supplemental Utility Assemblies. For each UAAA, the DB Contractor shall prepare a supplement to the Utility Assembly for the relevant initial MUAA (a “Supplemental Utility Assembly”), covering all Utility Adjustments addressed in the UAAA. The Supplemental Utility Assembly shall contain a transmittal memo, Utility Assembly Checklist, proposed UAAA cost estimate, a proposed UAAA which has been executed by the Utility Owner and the DB Contractor (one original in each of the two original Supplemental Utility Assemblies) including all required attachments, and applicable revisions to the Utility Adjustment Plans, as well as Affidavit(s) of Property Interest, if applicable. The transmittal memo shall briefly describe the desired amendment, and explain why the amendment is necessary. Each of the foregoing items shall comply with the requirements for same described in this *Technical Provision 8*.

Abbreviated Utility Assemblies. The DB Contractor shall prepare an Abbreviated Utility Assembly for each Utility proposed to remain at its original location within the Project ROW that is not required to be addressed in a MUAA or UAAA, or for a group of such Utilities. Each Abbreviated Utility Assembly shall contain a transmittal memo recommending that the subject Utility(ies) remain in place, a completed Utility Assembly Checklist, a certification from the Utility Owner approving leaving the Utility(ies) in place, as well as Affidavit(s) of Property Interest, if applicable. Each of the foregoing items shall comply with the requirements for same described in this *Technical Provision 8*.

8.12 Construction

8.12.1 General Construction Criteria

All Utility Adjustment construction performed by the DB Contractor shall conform to the requirements listed below. In addition, the DB Contractor is responsible for verifying that all Utility Adjustment construction performed by each Utility Owner conforms to the requirements described below. In case of nonconformance, the DB Contractor shall cause the Utility Owner (and/or its contractors, as applicable) to complete all necessary corrective Work or to otherwise take such steps as are necessary to conform to these requirements.

- All criteria identified in Technical Provision 8. 2.
- The Utility Adjustment Plans included in the Utility Agreement approved by the Mobility Authority (other than Utility Adjustment Field Modifications complying with Technical Provision 8.12.6.
- All Project safety and environmental requirements.
- The ROW acquisition schedule.

8.12.2 Inspection of Utility Owner Construction

The DB Contractor shall inspect all Utility Adjustment Work performed by Utility Owners (and their contractors) to verify compliance with the applicable requirements described in Technical Provision 8.12.1.

8.12.3 Scheduling Utility Adjustment Work

The Utility Adjustment Work may begin at any time following issuance of NTP1. The DB Contractor shall not arrange for any Utility Owner to begin any demolition, removal, or other construction Work for any Utility Adjustment until all of the following conditions are satisfied:

- The Utility Adjustment is covered by an executed MUAA and UAAA (and any conditions to commencement of such activities that are included in the Utility Agreement have been satisfied).
- Availability and access to any affected Replacement Utility Property Interest has been obtained by the Utility Owner (and provided to the DB Contractor, if applicable).
- The review and comment process has been completed and any required approvals have been obtained for the Utility Assembly covering the Utility Adjustment.
- All Governmental Approvals necessary for the Utility Adjustment construction have been obtained, and any pre-construction requirements contained in those Governmental Approvals have been satisfied.

- Any other conditions to that Work stated in the Contract Documents have been satisfied.

8.12.4 Standard of Care Regarding Utilities

The DB Contractor shall carefully and skillfully carry out all Work impacting Utilities and shall mark, support, secure, exercise care, and otherwise act to avoid damage to Utilities. At the completion of the Work, the condition of all Utilities shall be as safe and permanent as before.

8.12.5 Emergency Procedures

The DB Contractor shall provide emergency procedures with respect to Utility Adjustment Work in the PMP. The DB Contractor shall obtain emergency contact information from, and establish emergency procedures with each Utility Owner.

8.12.6 Utility Adjustment Field Modifications

The DB Contractor shall establish a procedure to be followed if a Utility Adjustment Field Modification is proposed by either the DB Contractor or a Utility Owner, after the Utility Assembly (which includes the Utility Adjustment Plans) has been approved. The procedure shall contain, at minimum, the following processes:

- The Utility Owner's review and approval of a Utility Adjustment Field Modification proposed by the DB Contractor, or the DB Contractor's review and approval of a Utility Adjustment Field Modification proposed by the Utility Owner.
- Submittal of plans for the proposed Utility Adjustment Field Modification to the Mobility Authority for its approval.
- Transmittal of Utility Adjustment Field Modifications to the appropriate construction field personnel.
- Inclusion of any Utility Adjustment Field Modifications in the Record Drawings for the Project.

The DB Contractor shall cause the procedure to be followed for all Utility Adjustment Field Modifications, whether the construction is performed by the DB Contractor or by the Utility Owner.

8.12.7 Switch Over to New Facilities

After a newly Adjusted Utility has been accepted by the Utility Owner and is otherwise ready to be placed in service, the DB Contractor shall coordinate with the Utility Owner regarding the procedure and timing for placing the newly Adjusted Utility into service and terminating service at the Utility being replaced.

8.12.8 Record Drawings

The DB Contractor shall provide Record Drawings to each Utility Owner for its Adjusted Utilities, in accordance with the applicable Utility Agreement(s).

The DB Contractor shall provide Record Drawings to the Mobility Authority (regardless of whether design and/or construction of the subject Utilities was furnished or performed by the DB Contractor or by the Utility Owner). These drawings shall show the location of, and label as such, all abandoned Utilities, shall show and label all other Utilities, whether remaining in place or relocated, located within the Final ROW or otherwise impacted by the Project. The DB Contractor shall provide the Record Drawings for each Adjustment to the Mobility Authority not later than 60 days after the Utility Owner accepts the Adjustment or before such earlier deadline as is specified elsewhere in the Contract Documents. The DB Contractor shall provide GPS coordinates of meters, manholes, valves, bends, fire hydrants, and encasements that are installed at a different location than that shown on the plans.

8.12.9 Maintenance of Utility Service

All Utilities shall remain fully operational during all phases of construction, except as specifically allowed and approved in writing by the Utility Owner. The DB Contractor shall schedule Utility Adjustment Work in order to minimize any interruption of service, while at the same time meeting the Project Schedule and taking into consideration seasonal demands.

8.12.10 Traffic Control

The DB Contractor shall be responsible for, and the traffic control plan shall cover, all traffic control made necessary by Utility Adjustment Work, whether performed by the DB Contractor or by the Utility Owner. Traffic control for Adjustments shall be coordinated with, and subject to approval by, the local agency(ies) with jurisdiction. Traffic control shall comply with the guidelines of the TMUTCD.

8.13 Submittals

The DB Contractor deliverables described in this *Technical Provision 8* shall be submitted in accordance with the Project Schedule, taking into account the Mobility Authority's designated review and response time pursuant to the DB Contract. All deliverables shall conform to the standards required in the DQMP and the CQMP.

8.13.1 Maximum Number of Submittals

The DB Contractor shall coordinate all Submittals required pursuant to this *Technical Provision 8*, so as not to overburden the Mobility Authority's staff and consultants. In each calendar week, the DB Contractor shall not submit more than:

- Four Utility Assemblies (excluding Supplemental or Abbreviated Utility Assemblies).

- Four of any documentation constituting any of the following:
 - A modified or additional item submitted in response to Mobility Authority comments on a particular Utility Assembly.
 - A Quitclaim Deed.
 - Any other type of relinquishment document.
- Two Supplemental Utility Assemblies.
- Two Abbreviated Utility Assemblies.

8.13.2 Utility Assembly Submittals

The following procedure shall govern submittal and review of each Utility Assembly, including Supplemental and Abbreviated Utility Assemblies:

- Before submitting a Utility Assembly to the Mobility Authority, the DB Contractor shall:
 - Submit the complete Utility Assembly to the quality control/quality acceptance entity designated by the DB Contractor in accordance with the PMP.
 - Resolve all comments made by the quality control/quality acceptance entity, coordinating with the Utility Owner as appropriate.
- The DB Contractor shall submit to the Mobility Authority three identical and complete originals of each Utility Assembly (each of which shall be bound and labeled “DB Contractor Copy,” “Mobility Authority Copy,” or “Utility Owner Copy,” as appropriate). These submittals shall be for the Mobility Authority's review and comment, except for any components of the Utility Assembly for which the Mobility Authority's affirmative approval is required by this Technical Provision 8.13.

Mobility Authority will review the Utility Assembly for compliance with the requirements of this Technical Provision 8.13.2, and within 10 Business Days shall return the Utility Assembly to the DB Contractor with the appropriate notations to reflect its responses. The DB Contractor shall transmit any Mobility Authority comments to the Utility Owner, and shall coordinate any modification, review and approval by the Utility Owner and resubmittal to the Mobility Authority, as necessary to resolve all Mobility Authority comments and/or obtain the Mobility Authority's approval, as applicable. Upon (a) the Mobility Authority's approval of any Utility Assembly components for which the Mobility Authority's approval is required, and (b) completion of the review and comment process for all other Utility Assembly components, the Mobility Authority will sign three originals of any approved Form 1082 or UJUA, whichever is applicable, and of any other components of the Utility Assembly for which this Technical Provision 8 requires the Mobility Authority's signature.

8.13.3 FHWA Federal Procedure

The DB Contractor shall develop the Federal Utility Procedure List that includes the Utility Owner’s name, approximate station numbers and estimated cost. The Mobility Authority will then submit to TxDOT the Federal Utility Procedure List in order to obtain TxDOT authorization for federal reimbursement. Promptly upon determining that any additional Utility Owner not referenced on the Federal Utility Procedure List is impacted by the project, the DB Contractor shall submit to the Mobility Authority all documentation as referenced above in order to update the Federal Utility Procedure List.

The Mobility Authority will forward the approved Federal Utility Procedure List (and any amendments thereto) to the DB Contractor, promptly upon receipt of same from TxDOT.

8.14 Submittals

Table 8-1: Submittals to Mobility Authority

Submittals	Submittal Schedule	Mobility Authority Action	Reference Section
Any proposed changes to the provided <i>Exhibit D - Item 4 – Utilities (Standard Utility Forms)</i>	As necessary	Approval	8.1
Meeting Agendas	3 Business Days in advance of each scheduled meeting	Information	8.7.2
Meeting Minutes	Draft meeting minutes 5 Business Days after the conclusion of the meeting	Review and Comment	8.7.2
DB Contractor’s Utility Strip Map	30 days before the first assembly package submission	Review and information	8.8.1
Utility Joint Use Acknowledgments	As part of UTR	Approval	8.8.3
Utility Tracking Report (UTR)	Monthly	Information	8.8.3
Affidavit of Property Interest	As part of the applicable Utility Assembly	Approval	8.9.2.1
Draft Quitclaim Deeds	As part of the applicable Utility Assembly	Approval	8.9.2.4

Table 8-1: Submittals to Mobility Authority

Submittals	Submittal Schedule	Mobility Authority Action	Reference Section
Executed Quitclaim Deeds	<ol style="list-style-type: none"> 1. Prior to recording deed in local real property records, and 2. Within 90 Days of completion of Utility Adjustment, or unless otherwise directed by Mobility Authority in writing 	Approval	8.9.2.4
TXDOT Online Permit	As part of the PUAA	Information	8.9.2.5
Project Utility Adjustment Agreement	After NTP1, based on the DB Contractor schedule	Approval	8.10.3
Utility Adjustment Agreement Amendments	After NTP1 based on the DB Contractor schedule	Approval	8.10.4
Utility Adjustment Concept Plan(s)	Within (i) 90 days after NTP2 or (ii) 30 days before the first assembly package submission (this plan is a working document and shall be continuously updated and modified as more project information becomes available) or (iii) upon TxDOT request	Review and, if applicable, Comment	8.11.1
Utility Adjustment Plans	In the applicable Utility Assembly	Approval	8.11.3 & 8.11.4
Utility Assemblies	Approval required prior to start of the affected Utility Adjustment Work	Approval	8.11.7
Supplemental Utility Assemblies	As necessary	Approval	8.11.7
Letter of Confirmation (relinquishment of interest once Adjustment completed) from Utility Owner and/or Utility Owner's authorized representative, if applicable	In the applicable Utility Assembly, including copy of unsigned Approved Draft Quitclaim Deed	Approval	8.11.7
Individual Record Drawing plans	90 days after Utility Owner accepts Adjustment	Approval	8.12.8

9.0 ENVIRONMENTAL COMPLIANCE

9.1 General

The DB Contractor shall be responsible for environmental compliance in accordance with the requirements identified in this *Technical Provision 9* and all applicable Laws and Governmental Approvals. The DB Contractor shall be responsible for creating environmental awareness among all project personnel, ensuring completion of environmental tasks and mitigation, and documenting that the environmental aspects of the Work are completed in accordance with all applicable Laws, Governmental Approvals, and the provisions of the Environmental Monitoring Program.

The DB Contractor shall be responsible for performing the environmental commitments reflected in the Environmental Documents and all other Governmental Approvals. Unless specifically noted in the DB Contract, all duties, responsibilities, and obligations assigned to the Mobility Authority in the Environmental Documents, hereby will be the responsibility of the DB Contractor.

The DB Contractor shall develop, implement, operate, and maintain an environmental protection program for the Work. The program shall require the DB Contractor to protect the environment and document the measures taken during the performance of the Work to minimize impacts on the environment from the design, construction and long-term operation of the Project.

The environmental protection program shall:

- Deliver the highest level of environmental commitment from the DB Contractor, as required by the Contract Documents, the Environmental Documents, Governmental Entities, Governmental Approvals, permits, Rules, and applicable Law.
- Establish and implement environmental goals consistent with those demonstrated by the Mobility Authority's actions in completing the Environmental Approval process.
- Implement and document environmental training of employees and encourage all the DB Contractor's group members to consider the natural environment in all Work activities.
- Demonstrate and relay the DB Contractor's environmental commitments to the Mobility Authority, the Governmental Entities, oversight groups, and the general public. Communication with the general public will be in accordance with *Technical Provision 4*.
- Establish and implement a "zero environmental violation" approach to all Work activities.
- The DB Contractor's program shall include environmental monitoring and reporting which must be concise and constant throughout the duration of the Work and shall be administered by the Environmental Compliance Manager (ECM).

- Report any and all violations of applicable environmental Laws and/or Rules and associated site conditions to the Mobility Authority and TxDOT within 24 hours after discovery or immediately for violations which are required by Law to have immediate notification of state or federal emergency response coordinators (i.e., the National Response Center) or appropriate contact, and in accordance with the notification requirements of the appropriate regulatory document or guidance.
- Address violations of environmental criteria, Environmental Approvals and commitments with appropriate and timely response.
- Unless directed otherwise, the DB Contractor shall be responsible for adhering to all Environmental Approvals and mitigation measures required for the Work, including those stated in the Environmental Documents and subsequent Environmental Approvals.
- The DB Contractor shall be responsible for environmental compliance in accordance with the requirements identified in this *Technical Provision 9* with the following adjustments and clarifications.

The DB Contractor acknowledges that Mobility Authority-Provided Approvals will be based on the Schematic Plan, *and* that such approvals may require amendment as the design progresses. The DB Contractor, with support and oversight by Mobility Authority, shall be responsible and bear the costs (excluding direct labor costs of the Mobility Authority) for all coordination with Governmental Entities necessary to obtain all such amendments to Mobility Authority-Provided Approvals and for ensuring compliance with the conditions and schedules set forth in the amendment of any Mobility Authority-Provided Approvals. Any additional mitigation required as a result of amendments or modifications to Environmental Approvals, except where such additional mitigation is required solely as a result of Mobility Authority-Directed Changes, shall also be borne by the DB Contractor. The DB Contractor shall comply with any mitigation requirements as a result of Mobility Authority-Directed Changes; however, the DB Contractor shall be entitled to compensation in accordance with Section 7.6.1.2 of the DBA.

Environmental Commitments

The DB Contractor is responsible for all commitments made in the Environmental Documents. The Finding of No Significant Impact (FONSI) for the Project is based on the final Environmental Assessment (EA) dated April 24, 2016, and the entire Project record. In addition, an Environmental Reevaluation was approved on February 6, 2020, which addresses design changes that have occurred since the issuance of the FONSI. The EA and the terms of the FONSI, in addition to all approved Environmental Reevaluations, together (the “Environmental Documents”) contain the commitments that must be met until final acceptance of the Project. A summary of major commitments is included in **Table 9-1**.

Table 9-1: Environmental Commitments

Resource/Issue	Commitment	Phase MET
Noise	<ul style="list-style-type: none"> • Construction, alteration, relocation or removal of sound walls as potentially required by Environmental Reevaluation(s). • Aesthetic treatment of sound walls (if required) would follow <i>Technical Provision 10</i>. • Construction noise minimization by use of mufflers, appropriate construction timing, and equipment placement. • Broad spectrum backup alarms shall be used on construction equipment. 	Construction
Vegetation & Wildlife Habitat / Landscaping	<ul style="list-style-type: none"> • Limit disturbance to areas necessary to construct project. • Avoid removal of native vegetation, particularly mature native trees and shrubs, to greatest extent practicable, e.g., preserving trees outside safety clear zone. • Use non-invasive native and locally-adapted seed mix in landscaping and re-vegetation of disturbed areas. • Landscaping with native trees and shrubs in accordance with TxDOT’s Roadside Vegetation Maintenance Manual –Vegetative Management Guidelines and in compliance with the intent of FHWA Executive Memorandum on Beneficial Landscapes and the FHWA Executive Order on Invasive Species. • Once construction is complete and disturbed areas have been revegetated, remove silt fences and accumulated sediment to reduce wildlife barriers and hazards. • Follow <i>Technical Provision 10</i>. 	Pre-Construction/ Construction/ Post-Construction

Resource/Issue	Commitment	Phase MET
Protected Species	<ul style="list-style-type: none"> • Compliance with the outcome of Section 7 Formal Consultation with USFWS for the Jollyville Plateau Salamander and five karst invertebrate species. • Work stoppage and notification of Mobility Authority if Threatened and Endangered Species observed in the Project area. • If, during construction, a karst void (potential habitat for endangered karst species) is encountered, work in the vicinity of the void would immediately cease, and TxDOT and the Mobility Authority would be notified. The void would be evaluated in accordance with USFWS survey protocols and any requirements resulting from Section 7 Consultation with USFWS by TxDOT and/or the Mobility Authority (see <i>Technical Provision 9.2.2</i>). No construction activity would be allowed in the vicinity of the void until approved by TxDOT and the Mobility Authority. • Further investigation will be required if new Threatened and Endangered Species or habitats are listed that are likely to occur in the Project area. • To mitigate potential for groundwater quality impacts to the Jollyville Plateau salamander resulting from construction of the proposed Project, a comprehensive system of water quality Best Management Practices (BMPs) would be employed, proactively monitored and aggressively maintained throughout the construction phase. Post-construction (permanent) water quality controls would be designed to achieve, at least, the 80 percent Total Suspended Solids removal standard required by the Edwards Aquifer Rules (see <i>Technical Provision 9.2.2</i>). This commitment is subject to supplementation or alteration based on the outcome of Section 7 Consultation with USFWS. • In the area between Hunters Chase and McNeil Drive (the extent of Drainage Basin E referenced in the Water Quality Technical Report), permanent controls would exceed the Edwards Rules requirement by achieving removal of at least 85 percent of TSS from the area of increased impervious cover. • Bridge Bat BMPs: All bat surveys will comply with Texas Parks & Wildlife Department recommended white-nose syndrome protocols. Habitat assessment will be conducted by a qualified biologist to determine if bats are present. If bats are present, appropriate measures will be taken as practicable to ensure that bats are not harmed, such as exclusion of timing activities. For maternity colonies, exclusion activities should be timed to avoid separating lactating females from nursing pups. If structures used by bats are removed as a result of construction, replacement structures should incorporate bat-friendly design or artificial roosts should be constructed to replace these features as practicable. • The DB Contractor will be advised of potential occurrence of the Texas garter snake in the project area and to avoid harming the species if encountered. 	Pre-Construction/ Construction/ Post-Construction
Jurisdictional Waters / Special Aquatic Sites	<ul style="list-style-type: none"> • Compliance with USACE Nationwide Permit 14 (with or without pre-construction notification, as appropriate) for unavoidable temporary and permanent impacts (see <i>Technical Provision 9.2.2</i>). • Enforcement of a Storm Water Pollution Prevention Plan (SW3P) including implementation of appropriate Section 401 Water Quality certification BMPs (see <i>Technical Provision 9.2.2</i>). • A wetland delineation has been performed for the current project design and a report of the results prepared. Any changes to the current design will need additional wetland impact investigations. Those wetland field investigations must be performed in accordance with the USACE 1987 Wetlands Delineation Manual (and Great Plains Regional Supplement) and delineate and record any wetlands identified. Mitigation of impacts shall follow guidance of Section 404 of the CWA. 	Pre-construction (design, permit notification)/ Construction

Resource/Issue	Commitment	Phase MET
Migratory Bird Nesting	<ul style="list-style-type: none"> • Migratory bird nest surveys will be performed to adhere to the Migratory Bird Treaty Act. The surveys will need to be performed when any clearing of trees or demolition of bridges and culverts take place during nesting season, typically February 15 to October 1. • Appropriate measures taken to avoid adverse impacts on migratory birds will be coordinated with the TxDOT-Austin District biologist in advance of implementation, and would include the following: <ul style="list-style-type: none"> ○ The removal or destruction of active migratory bird nests (nests containing eggs and/or young) at any time of the year would be prohibited until the nests become inactive, usually between October 1 and February 15. ○ If colonial nesting (i.e. swallows) occurs on or in structures, nests would not be removed until all nests in the colony become inactive. ○ The DB Contractor shall remove inactive bird nests between October 1 and February 15 from any structure where Work will be done and prevent migratory birds from building nests between February 16 and September 30. For structures that are being widened, inactive nests will be removed from the entire structure. • All construction methods must be approved by the Mobility Authority's designated environmental manager well in advance of planned use. 	Pre-construction/ Construction
Floodplains	<ul style="list-style-type: none"> • Coordination with the local FEMA floodplain administrator (City of Austin) for Project encroachment in floodplains (see <i>Technical Provision 9.2.2</i>). 	Pre-construction/ Construction
Shared Use Path	<ul style="list-style-type: none"> • Construct Shared Use Path as shown in environmental schematic. • Construct sidewalks to complete gaps between existing sidewalks as shown in the environmental schematic. 	Pre-construction/ Construction

Resource/Issue	Commitment	Phase MET
Water Quality / Stream Channel	<ul style="list-style-type: none"> • Edwards Aquifer Water Pollution Abatement Plan (WPAP), authorizing regulated activities over the Edwards Aquifer Recharge Zone from the Project during and after construction, will be prepared and submitted to TCEQ for review and approval prior to commencement of construction (see <i>Technical Provision 9.2.2</i>). • Stormwater treatment planning (SW3P), including Section 401 BMPs, implementation, monitoring/maintenance, and removal. • Field inspection every 7 days. Reseeding or restabilization of disturbed areas within 14 days. • Minimize water quality impacts through the implementation of SW3P and comply with conditions of the 401 certification (see <i>Technical Provision 9.2.2</i>). Maintain all permanent and temporary controls as indicated in the SW3P, the 401 certification, and as required by the Mobility Authority and Governmental Entities. • Suitable BMPs shall comply with Storm Water Management Guidelines for Construction Activities. • -Comply with the TCEQ Storm Water Program regulations. • -Obtain the TCEQ General Permit for Stormwater discharges from Large Construction Activities (see <i>Technical Provision 9.2.2</i>). • Prepare and submit a NOI and SW3P for review and acceptance. • Seal any domestic water wells in accordance with TCEQ well abandonment procedures prior to roadway construction. • Coordinate with owner(s) of environmental monitoring wells of intent to plug and abandon wells within the Project ROW. • Minimize the use of equipment in streams and riparian areas during construction. When possible, equipment access should be from stream bank or top of culvert. • When temporary stream crossings are unavoidable, remove stream crossings once they are no longer needed and stabilize banks and soils around the crossing. • An Edwards Aquifer Organized Sewage Collection System Plan (SCS) may be required for regulated activity involving sanitary sewer infrastructure. An SCS must be submitted to and approved by TCEQ prior to commencement of regulated activity involving sanitary sewer infrastructure. 	Pre-Construction/ Construction/Post- Construction
Cultural Resources	<ul style="list-style-type: none"> • Intensive pedestrian Archeological Survey of Schematic ROW and easements by qualified archeologists. • In the unlikely event that cultural resources are discovered during construction of the proposed project, TxDOT would immediately initiate cultural resource discovery procedures. All work in the vicinity of the discovery would cease until a specialist from TxDOT and/or the THC could arrive on site and assess the discovery's significance and the need, if any, for additional investigation.- Coordination by TxDOT and acquisition of all necessary Antiquities Permits by the DB Contractor's archeologist from the THC required for surveys of areas outside of the Schematic ROW if Additional Properties are acquired due to Schematic Plan changes. Identification and testing for cultural resources for Additional Properties and all staging areas, field office sites, borrow sites, and stockpile locations. 	Completed Pre-construction/ Construction
Air Quality	<ul style="list-style-type: none"> • Proper maintenance and idling of construction equipment to control particulate matter emissions. • Watering, chemical stabilization, construction vehicle speed reduction, as feasible, to control dust. 	Construction

Resource/Issue	Commitment	Phase MET
Community Impacts	<ul style="list-style-type: none"> • Disruptions from construction would be minimized to the extent possible by the timely notification of affected residents and business owners through posted notices, personal contact, or other notification procedures. These procedures would include rerouting traffic, barricading, using traffic cones, or any other measures deemed necessary and prudent by TxDOT and the DB Contractor to comply with all local, State and Federal traffic and safety regulations. • Signage and barrier placement should be alert to the inevitable reordering of travel patterns, both during construction and in the long term, as drivers find cut-through routes to shorten travel times. • During construction, procedures to minimize traffic congestion and risk to public safety should be specifically adapted to the circumstances of the Project. 	Construction/Post-construction
Hazardous and/ or Contaminated Materials	<ul style="list-style-type: none"> • Any unanticipated hazardous materials and/or petroleum contamination encountered during construction would be handled in accordance with applicable Federal and State regulations, per TxDOT Section 6.10 of the General Provisions of the Standard Specifications for Construction and Maintenance of Highways, Streets and Bridges addressing the contractor’s responsibilities regarding the discovery of hazardous materials during construction. • The DB Contractor shall determine the depth to groundwater at locations where construction is going to occur adjacent to sites of concern to determine the likelihood of reaching groundwater and to determine whether contaminants held in groundwater would be likely to impact construction. • If acquisition of property is required for water quality detention ponds near LPST sites, the DB Contractor shall conduct a Phase I Environmental Site Assessment to the applicable ASTM standard (E 1527-13) prior to (and within 180 days or 6 months of) the acquisition. 	Pre-construction/ Construction

9.2 Environmental Approvals

9.2.1 Mobility Authority-Provided Approvals

Environmental Documents have been prepared by the Mobility Authority, or its representatives, during the planning phase of the Project to obtain certain Environmental Approvals, which specify mitigation requirements and recommendations. Mobility Authority-Provided Approvals are based on the Schematic ROW associated with the Schematic Plan as presented in the Environmental Documents.

9.2.2 DB Contractor Responsibility for Obtaining Environmental Approvals

As part of the Work, the DB Contractor shall obtain all required Environmental Approvals other than the previously secured Mobility Authority-Provided Approvals. In cases that require the Mobility Authority or TxDOT to act as the coordinating party, the DB Contractor shall provide all required data and support necessary to secure such Environmental Approvals. The following is a list of potential Environmental Approvals that the DB Contractor may be required to obtain for the Project or provide assistance to the Mobility Authority for Mobility Authority-Provided Approvals:

- Texas Pollutant Discharge Elimination System (TPDES) Construction General Permit for storm water pollution discharges from construction sites. A Notice of Intent (NOI) must be

filed with the Texas Commission on Environmental Quality (TCEQ), and a SW3P must be prepared for the Work, as required by the TCEQ.

- Endangered Species Act (ESA). Formal Consultation currently under way with the U.S. Fish and Wildlife Service (USFWS) under Section 7 of the ESA will likely result in Project requirements pertaining to habitat of the Jollyville Plateau salamander and five karst invertebrate species. Additional consultation will be required if new species or habitats are listed as potentially occurring in proximity to the Project or if changes to the Schematic Plan affect listed species or habitats not addressed in Mobility Authority-Provided Approvals. Additionally, consultation will be necessary if listed species or habitats, above and beyond that addressed in Mobility Authority-Provided Approvals, are discovered within the Project area.
- Section 404 Permit – Clean Water Act (CWA). To meet the requirements set forth in USACE Nationwide Permit (NWP) 14, the DB Contractor shall span all waters of the US or if Work is performed below the ordinary high water mark, stay within the criteria limits of the NWP 14. If design changes to the Schematic Plan result in compensatory mitigation, the DB Contractor shall implement any USACE approved compensatory mitigation plan for impacts to jurisdictional waters. A Pre-construction Notification (PCN) will be required if impacts exceed 0.10 acre at any one jurisdictional crossing.
- Section 401 CWA Water Quality Certification . The DB Contractor shall be required to comply with the State of Texas Water Quality Certification Program by implementing erosion control and pollution prevention BMPs from the TCEQ’s Section 401 Water Quality Certification Conditions for NWPs as outlined in the SW3P.
- Section 106 of the National Historic Preservation Act (NHPA). TxDOT has conducted intensive archeological and historic surveys within the Schematic ROW required for archeological and historic sites and clearance from THC has been obtained for the Schematic Plan. Acquisition of Additional Properties may result in the need for additional clearance from THC.
- National Flood Insurance Program (NFIP) authorization from FEMA, for impacts to 100-year floodways and/or floodplains of designated waterways. This authorization may be obtained through coordination with the local Floodplain Administrator (City of Austin). It is not anticipated that the Project would increase the base flood elevation to a level that would violate applicable floodplain regulations and ordinances; however, review and comment by FEMA may be required if proposed construction were to cause an increase in the base flood elevation in excess of that allowed under the governing rules of the NFIP. In that case, extensive hydrologic and hydraulic analysis and the submittal of a Conditional Letter of Map Revision pursuant to the NFIP regulations to the appropriate authorities for review(s) and approval(s) prior to the beginning of construction within the NFIP regulated areas could be required, and the submittal of a Letter of Map Revision pursuant to the NFIP regulations to the appropriate authorities for review(s) and approval(s) following construction within the NFIP regulated

areas could also be required. The Mobility Authority, in conjunction with TxDOT, will make a determination if detailed coordination with the local floodplain administrators and FEMA is required. The DB Contractor shall be responsible for the Conditional Letter of Map Revision and/or Letter of Map Revision, if required.

- Edwards Aquifer Rules. The Project is located over the Edwards Aquifer Recharge Zone. Accordingly, the DB Contractor shall complete and implement a TCEQ-approved Water Pollution Abatement Plan (WPAP), which would authorize discharges over the Edwards Aquifer Recharge Zone from the project during and after construction. The DB Contractor shall prepare and submit the WPAP to TCEQ for review and approval prior to commencement of construction (see *Technical Provision 9.3.12*). An Edwards Aquifer Organized Sewage Collection System Plan (SCS) may be required for regulated activity involving sanitary sewer infrastructure. An SCS must be submitted to and approved by TCEQ prior to commencement of regulated activity involving sanitary sewer infrastructure.

If previously issued Environmental Approvals become invalid or need amending due to changes to the Schematic Plan, the DB Contractor, with the support and oversight of the Mobility Authority, shall be responsible for application revisions, supplements, reassessment and coordination with appropriate Governmental Entities as necessary to secure or amend Environmental Approvals. Additional costs and delays to the Work associated with securing additional Environmental Approvals shall be addressed in accordance with the provisions of Section 7.5, Section 7.6 and Section 14 of the DBA.

9.2.3 Coordination Between The DB Contractor, The Mobility Authority and Regulatory Agencies

The DB Contractor shall prepare all applications for Environmental Approvals other than Mobility Authority-Provided Approvals. The Mobility Authority will review and approve the applications, sign as the applicant where and if required, and return the documentation to the DB Contractor for submittal to the appropriate Governmental Entity. The Mobility Authority shall be provided a reasonable opportunity to review and approve completed applications and supporting documentation for Environmental Approvals prior to their submission and shall have the right to disapprove the same by written notice to the DB Contractor. Copies of all environmental submittals, correspondence, and secured Environmental Approvals shall be provided to the Mobility Authority and maintained in accordance with the guidelines of *Technical Provision 1* along with related requirements found within this *Technical Provision 9*.

The DB Contractor shall, with the Mobility Authority oversight, negotiate Environmental Approvals and conditions with appropriate Governmental Entities. The DB Contractor shall consult and coordinate with the Mobility Authority on all negotiations concerning Environmental Approvals. In cases that require the Mobility Authority or TxDOT personnel to act as the coordinating party, such as consultation with the USFWS, the DB Contractor shall provide required personnel support and data concerning Work and potential environmental impacts necessary to secure Environmental Approvals.

9.3 Performance Requirements

9.3.1 Environmental Mitigation Guidelines

9.3.1.1 Development of the Project Mitigation Plan

If substantial changes to the current Schematic Plan are made, the DB Contractor shall develop a Project Mitigation Plan that fully details the mitigation requirements for the new design. A Project Mitigation Plan may require the preparation of the following Environmental Documents as applicable to the Project:

- Reevaluation of the EA.
- Permits secured from Governmental Entities.

Modifications due to the environmental impacts of the Final Design shall be assessed and provided by the DB Contractor. The DB Contractor accepts and recognizes that during Environmental Approval coordination procedures with Governmental Entities, additional resource-specific mitigation plans, such as for jurisdictional waters may be required to procure Environmental Approvals. The DB Contractor shall coordinate and implement these additional resource-specific mitigation plans. The Project Mitigation Plan shall be updated as needed, to reflect resource-specific mitigation plans as developed and approved by the Mobility Authority and Governmental Entities. Delays or added costs resulting from revisions to the Project Mitigation Plan will be addressed in accordance with the provisions set forth in the Section 14 of the DBA.

9.3.1.2 Compliance with Mitigation Requirements

The DB Contractor shall prepare all Final Designs and specifications for any environmental mitigation required for the Work. Any additional mitigation required as a result of amendments or modifications to Environmental Approvals except where such additional mitigation is required solely as a result of Mobility Authority-Directed Changes shall also be borne by the DB Contractor.

9.3.2 Hazardous Materials Requirements

The DB Contractor shall prepare a plan for the safe handling, storage, treatment and/or disposal of Hazardous Materials that are brought onto the Site by the DB Contractor during performance of the Work (“Hazardous Materials Management Plan”). The Hazardous Materials Management Plan shall include, at a minimum (1) a listing of all Hazardous Materials, and for each the quantities, a brief description of the hazardous characteristics and the Safety Data Sheet (SDS); (2) defined appropriate storage practices, including designation of approved containers, container labeling, and storage locations; (3) designated responsible individuals, and (4) procedures for proper disposal. The Hazardous Materials Management Plan shall also include a plan for personnel training addressing management and response to hazardous waste situations and a contingency plan for any spills or releases, including response and/or containment procedures and reporting requirements. Lastly, the Hazardous Materials Management Plan shall address procedures for preparing Phase II Sampling and preliminary assessment Scopes of Work for suspect

Hazardous Materials Sites, and Investigative Work Plan (IWP) and Site Investigation Report (SIR) reports in the event that Hazardous Materials are discovered during construction activities. The Hazardous Materials Management Plan shall be updated monthly, or as directed by the Mobility Authority. The DB Contractor shall submit the Hazardous Materials Management Plan to the Mobility Authority for its approval within 90 Days after issuance of NTP 1. The DB Contractor shall revise the Hazardous Materials Management Plan to address the Mobility Authority's comments. The DB Contractor shall not commence construction and NTP 2 will not be issued until the Hazardous Materials Management Plan has been approved in writing by the Mobility Authority in its sole discretion.

The DB Contractor shall have Synthetic Absorbents and Absorbent Pads, for spilled petroleum products, for all work near water bodies.

9.3.2.1 *Previously Documented Hazardous Material Sites*

During the Environmental Documents process, federal and state regulatory environmental databases were searched in general conformance with the recommended search distances referenced in *ASTM Practice E-1527-13* and an Initial Site Assessment was conducted. Details concerning documented Hazardous Materials sites, if identified, are provided in the Environmental Documents. The Final Hazardous Materials Technical Report identifies known Hazardous Materials sites and Recognized Environmental Conditions, including Leaking Petroleum Storage Tank (LPST) sites, within or adjacent to the Project ROW. Sites #18 and #75, as indicated in the EA, are LPST sites with groundwater contamination. Sites #37 and #82 are former dry cleaning facility sites with groundwater contamination. Findings of the Initial Site Assessment and Final Hazardous Materials Technical Report were that contamination may be avoided from these four sites if depth of construction remains above the groundwater level, which was estimated to range from 10 to 35 feet below ground surface, depending on the site. The DB Contractor shall determine the depth to groundwater at these locations to determine the likelihood of reaching groundwater and to determine whether contaminants held in groundwater would be likely to impact construction. In addition, two existing or proposed water quality ponds (Pond 5 and Pond 7) are located near LPSTs. If ROW acquisition is required for Pond 5 and/or Pond 7, the DB Contractor shall conduct Phase I Environmental Site Assessments to the applicable ASTM standard (*E 1527-13*) prior to (and within 180 days or 6 months of) the acquisition of properties potentially affected by sites of concern in proximity to water quality ponds. The DB Contractor shall be responsible for the investigation and appropriate remediation of Hazardous Materials in accordance with applicable Law and Project guidelines set forth in *Technical Provision 9.3.2.3*.

DB Contractor-initiated design changes to the Schematic ROW may result in impacts to the previously documented Hazardous Material sites in the corridor. Additionally, the development of Additional Properties, such as staging areas, field office sites, borrow sites, stockpile locations and other areas, may also result in impacts to the known Hazardous Material sites. In both cases, the DB Contractor shall be responsible for the investigation of potential Recognized Environmental Conditions (as defined in ASTM *E-1527-13*) and appropriate remediation of Hazardous Materials in accordance with applicable Law and Project guidelines set forth in *Technical Provision 9.3.2.3*.

Hazardous Materials contamination shall be taken into account by the DB Contractor during all subsequent phases of Project development including ROW negotiation and acquisition, property management, design, and construction.

9.3.2.2 *Undocumented Hazardous Materials*

For the following described sites, the DB Contractor shall investigate the presence of Hazardous Materials in accordance with the requirements and multi-component approach set forth in ASTM Standard *E-1528-14e1, Standard Practice for Limited Environmental Due Diligence: Transaction Screen Process*. Reference to such ASTM standards shall include the tasks and procedures described therein.

- Design changes requiring Additional Properties outside of the previous search corridor.
- The DB Contractor's Project Specific Locations (PSLs) as defined by the FHWA PSL Quickguide.
- Unrecorded sites/materials discovered during Work.

If previously unknown Hazardous Materials or other potential Recognized Environmental Conditions are encountered or suspected in the soil and/or shallow groundwater of the Schematic ROW, mitigation sites, or any parcels added during construction operations, appropriate measures for the proper assessment, characterization, remediation, and management of the contamination shall be initiated and performed in accordance with applicable Law. The DB Contractor shall be entitled to compensation as described in the Section 7.5, Section 7.6 and Section 14 of the DBA.

9.3.2.3 *Hazardous Materials Planning and Investigation*

The DB Contractor shall investigate the following for the presence of Hazardous Materials:

- Schematic ROW (previously investigated in the Initial Site Assessment for the Project).
- Additional Properties.
- DB Contractor's design changes to the Schematic Plan.
- DB Contractor's staging areas, field office sites, borrow sites, or stockpile locations.

If Hazardous Materials are encountered, then the DB Contractor shall prepare an IWP that addresses the methods, techniques, and analytical testing requirements to adequately characterize the extent of the contaminated media (soil and/or groundwater) potentially impacting the Project. The DB Contractor shall assess the likely source of contamination and assess the Mobility Authority's responsibility with regard to such contamination.

The level of investigation and remedial action ultimately performed will be determined based on the “Responsible Party” status of Mobility Authority. “Responsible Party” status refers to which party is responsible for the corrective or preventive action. If the Mobility Authority is responsible for the

contamination, full corrective action may be required. “Corrective Action” is the cleanup, removal, or stabilization of Hazardous Materials-contaminated soil and/or groundwater as required for compliance with Environmental Laws. However, if the Mobility Authority is not the Responsible Party, the extent of any response will be “preventive” in nature rather than “corrective.” “Preventive Action” refers to the cleanup, removal, or stabilization of Hazardous Materials-contaminated soil or groundwater required facilitating construction of the Project. In contrast with Corrective Action, Preventive Action is concerned primarily with worker health and safety issues as well as taking all appropriate steps to ensure that the proposed construction will not make worse, or aggravate, the existing contamination.

A Registered Professional Engineer and other qualified professionals, as needed, shall prepare the IWP and other necessary reports in accordance with applicable TCEQ regulations and guidance. The IWP shall contain the following elements, at a minimum:

- DB Contractor's plan and schedule for characterization of all areas of the Final ROW and Work, where Hazardous Materials may reasonably be expected to be encountered, including a Sampling and Analysis Plan describing sampling locations, methods, and criteria for sample selection; media to be sampled; laboratory analyses, methods and quantification limits; investigation schedule, site security measures; location and layout of work zones, storage areas, and decontamination areas; management of investigation derived waste, and quality assurance/ quality control procedures.
- DB Contractor's plan and schedule for identifying and eliminating or controlling potential risks to site workers, the public and the environment. This portion of the IWP should be developed in accordance with the DB Contractor's Safety and Health Plan.

Following review by the Mobility Authority, the DB Contractor shall submit the IWP to the applicable TCEQ program as appropriate and if required, for review and approval prior to implementing fieldwork activities. The DB Contractor shall then implement the plan and complete all investigative activities necessary in accordance with the IWP and applicable TCEQ regulations and guidance.

Upon satisfactorily completing the investigative Work, the DB Contractor shall summarize the findings within a SIR and make recommendations regarding potential response actions necessary for Project development. The DB Contractor shall take Hazardous Materials contamination into account during all subsequent phases of Project development including ROW negotiation and acquisition, property management, design, and construction.

Issues to be addressed in the SIR include: the characterization of the impacted area; sampling efforts and findings; opportunities to avoid the contamination by adjusting the design; level of response action warranted if the contamination cannot be avoided; feasibility of initiating response actions prior to construction; pursuit of cost-reimbursement from responsible parties; the need for completing response actions concurrent with construction; and nature of any special specifications and provisions necessary for incorporation into the Project.

Following review by the Mobility Authority, scopes of work may be developed to initiate additional Work as may be required.

All investigations and plans shall be completed in full conformance with applicable Federal and State standards, including TCEQ, OSHA, USDOT, EPA, and Mobility Authority standards, and applicable supplemental and special provisions.

9.3.3 Noise/Sound Abatement Requirements

9.3.3.1 Construction Noise Mitigation

The DB Contractor shall implement appropriate measures to minimize construction noise. The DB Contractor shall implement a training program to ensure employees and subcontractors are educated as to the construction noise abatement requirements, see *Technical Provision 9.5*.

9.3.3.2 Sound Wall Construction

Revisions to the original Project design include a proposed direct connector from the southbound express lanes that will provide direct access to the existing MoPac (Loop 1) frontage roads in the form of a distributor lane that extends just south of Far West Boulevard. The addition of the direct connector and associated distributor lane necessitates relocating a previously installed sound wall. The Environmental Reevaluation has determined that a combination of two relocated sound walls would replace the sound wall to be demolished and that the new walls are feasible and reasonable. The DB Contractor shall incorporate the relocated sound walls into the design and construction of the Project, consistent with the sound wall location and dimensions indicated in the Traffic Noise Abatement Memorandum attached to the Environmental Reevaluation. For sound walls that are to be altered, relocated or removed, the DB Contractor shall notify affected property owners to discuss the changes per *TxDOT's Environmental Handbook for Traffic Noise and Guidelines for Analysis and Abatement of Highway Traffic Noise*.

Sound walls to be relocated and reconstructed by the DB Contractor shall meet the height, length, and horizontal location as indicated in the Traffic Noise Abatement Re-Evaluation Memorandum attached to the Environmental Reevaluation.

Height: The top of walls shall be the height cited in the Traffic Noise Abatement Re-Evaluation Memorandum attached to the Environmental Reevaluation.

Length: The beginning and ending of the walls shall be within 3 feet of those shown in Figure 2 of the Traffic Noise Abatement Re-evaluation Memorandum attached to the Environmental Reevaluation.

Horizontal Location: The horizontal location of the walls shall be within 3 feet of the location shown in Figure 2 of the Traffic Noise Abatement Re-Evaluation Memorandum attached to the Environmental Reevaluation.

The DB Contractor will be responsible for performing noise analyses for changes initiated by the DB Contractor that require such analysis per TxDOT's *Environmental Handbook for Traffic Noise and Guidelines for Analysis and Abatement of Highway Traffic Noise*.

9.3.3.3 *Aesthetics/Appearance:*

Sound walls shall meet requirements found in *Exhibit C – Attachment 10-1 – 183 North Mobility Project Aesthetic Design Guide*.

9.3.4 *Air Quality Mitigation*

The DB Contractor shall implement all required emission reduction measures required under applicable Laws and/or Rules pertaining to the minimization of impacts on air quality due to emissions and airborne dust. The DB Contractor shall utilize a combination of watering, chemical stabilization, vehicle speed reduction (to 20 miles per hour) to minimize and control dust, proper maintenance and idling of construction equipment to control particulate matter emissions and other air quality impacts of the Work. If airborne dust levels exceed acceptable levels, the DB Contractor shall water the construction sites to reduce the dust to the extent practicable or shall implement other environmentally sound means as appropriate. Watering and other mitigation measures to minimize air quality impacts shall be increased as necessary based on construction traffic, forecasted wind speeds, and persistent dry weather conditions.

9.3.5 *Wildlife and Vegetation*

The DB Contractor shall be responsible for designing and conducting all construction in accordance with applicable Laws pertaining to the avoidance and minimization of impacts on wildlife and vegetation and in accordance with the Environmental Approvals.

If changes to the Schematic Plan initiated by the DB Contractor result in impacts to areas outside of the Schematic ROW described in Mobility Authority-Provided Approvals, a field determination of wildlife and vegetation impacts will be required for all Additional Properties, as well as the DB Contractor's staging areas, field office sites, borrow sites, and stockpile locations.

9.3.5.1 *Wildlife and Vegetation Mitigation*

The DB Contractor shall be responsible for implementing all mitigation measures to minimize construction and long-term impacts of the Work as prescribed in Mobility Authority-Provided Approvals and subsequent Environmental Approvals secured by the DB Contractor. Wildlife and vegetation mitigation measures shall include, but not be limited to, demarcation of sensitive wildlife areas, protection of active bird nests, control of invasive plant species, and employee/subcontractor training.

9.3.5.2 *Threatened and Endangered Species*

The proximity of Critical Habitat for the Jollyville Plateau salamander and the potential for encountering karst formations providing habitat to five other federally Protected Species is currently the subject of Formal Consultation with the USFWS under Section 7 of the ESA. The DB Contractor shall implement mitigation measures required for the project as a result of Section 7 Consultation. Other species in the region may become listed as Threatened and Endangered Species during the life of the Work that were not previously addressed in Mobility Authority-Provided Approvals. In addition, unrecorded sites with currently listed Threatened or Endangered Species may be discovered during pre-construction surveys or during construction. The DB Contractor shall be responsible for additional surveys, providing support for consultation with Governmental Entities, and implementation of mitigative measures required to address potential impacts to these species. The DB Contractor shall also be responsible for additional surveys, consultations, and mitigation measures to address impacts to previously documented species due to DB Contractor-directed changes to the Schematic ROW. The DB Contractor shall avoid impacts to potential habitat for several federally listed Threatened and Endangered Species that occurs adjacent to and in the vicinity of the Project, which possibly could be affected by changes to the Schematic ROW. Costs and delays of Work relating to Threatened and Endangered Species listed following NTP 1 will be handled in accordance with the provisions of Section 7 and Section 14 of the DBA.

The DB Contractor shall not conduct any clearing or construction activities in Threatened and Endangered Species habitat, except for those activities specifically authorized in Mobility Authority-Provided Approvals and subsequent Environmental Approvals. Mobility Authority-Provided Approvals and subsequent Environmental Approvals do not cover ancillary development on Additional Properties and the DB Contractor will be responsible for securing any Environmental Approvals necessary in cooperation with TxDOT and in accordance with all applicable Laws regarding Threatened and Endangered Species.

If changes to the Schematic Plan initiated by the DB Contractor result in impacts to areas outside of the Schematic ROW, a determination of potential impacts to Threatened and Endangered Species habitat will be required for all Additional Properties, as well as the DB Contractor's staging areas, field office sites, borrow sites, and stockpile locations. Results of the surveys shall be presented to the Mobility Authority, which will review the DB Contractor recommendations. If recommendations warrant, after coordination with the Mobility Authority, TxDOT will coordinate with USFWS, or the DB Contractor will select an alternate site. Alternate sites selected by the DB Contractor will require approval by the Mobility Authority.

9.3.5.3 *Mitigation Requirements*

The DB Contractor shall furnish the necessary personnel, materials, services, equipment and facilities, and otherwise do all things necessary for and incidental to the performance of the construction in a manner consistent with accepted professional standards and procedures found in *50 CFR Part 402.12* pertaining to consultation procedures under the ESA. The DB Contractor shall comply with the ESA and applicable implementing regulations.

9.3.6 Cultural Resources

The DB Contractor shall be responsible for conducting cultural resource surveys and providing support for coordination with Governmental Entities, with the Mobility Authority review and oversight, associated with Additional Properties. The DB Contractor is responsible for the protection of known and currently unidentified historic properties, archeological, and/or paleontological sites, or other items of cultural significance encountered during the design and construction of the Work, in compliance with Section 106 of the NHPA, the Antiquities Code of Texas, and other applicable Laws. Existing information is included in Exhibit D – Item 2 – Environmental (Cultural Resources).

If evidence of a possible archeological or historic property is encountered during the course of the Work, the DB Contractor shall immediately cease Work in the immediate area and contact the Mobility Authority. The DB Contractor shall undertake appropriate measures to protect the site from further intrusion to the extent feasible until an appropriate evaluation of the site can be made by a qualified representative. Work shall not resume in the area until the DB Contractor receives notification and approval from the Mobility Authority.

9.3.6.1 Compliance with Existing Agreements

The DB Contractor shall comply with the mitigation and performance requirements in Mobility Authority-Provided Approvals, including but not limited to the Programmatic Agreement (PA) between the FHWA, Advisory Council on Historical Preservation, TxDOT and THC, and the Memorandum of Understanding (MOU) between THC and TxDOT relative to THC review of TxDOT projects.

9.3.6.2 Pre-Construction Responsibilities

Prior to the initiation of any construction activities on Additional Properties, including clearing and staging operations, the DB Contractor shall be responsible for identification of cultural resources and testing for archeological resources for the Additional Properties and all the DB Contractor's PSLs. All identification and testing shall be conducted by qualified firms/individuals and, for archeology, shall involve ground examination, with subsurface testing in areas that exhibit the potential for buried archeological deposits. The DB Contractor, with the Mobility Authority oversight, shall be responsible for conducting identification and testing for cultural resource investigations in accordance with all applicable Laws as necessary to secure clearances. The DB Contractor shall submit a Cultural Resource Pre-Survey Report to the Mobility Authority providing:

- The initial Archeological Survey application permit.
- The location of the DB Contractor's properties to be surveyed.
- The intended use of each Additional Property.

NOTE: *The Mobility Authority will review the DB Contractor recommendations.*

- A brief statement of qualifications of the firm/individual conducting the survey.

- The survey methodology.

The DB Contractor shall prepare technical reports presenting the results of the identification and testing for cultural resources of the DB Contractor's properties and the Additional Properties for review by the Mobility Authority and submittal to the State Historic Preservation Officer. The DB Contractor will be responsible for all costs associated with additional cultural resource surveys, testing, and report preparation for the DB Contractor's properties and Additional Properties.

***NOTE:** If during identification, the DB Contractor finds evidence of a cultural resource site potentially eligible for the National Register of Historic Places in a proposed Additional Property, the DB Contractor will be responsible for selecting an alternate Additional Property if an acceptable alternate Additional Property is available, or if an acceptable alternate Additional Property is not available, conducting archeological testing if applicable, necessary, and agreed to by the Mobility Authority in its sole discretion.*

The DB Contractor shall avoid and minimize impacts to cultural resources, when feasible, during the site selection process for all Additional Properties. The Mobility Authority and TxDOT will be responsible for coordinating and conducting any data recovery activities for cultural resources identified on the Additional Properties, in the event an acceptable alternate property cannot be identified. An acceptable alternate Additional Property must (i) accommodate the stated purpose; (ii) to the extent possible, avoid impacts to Section 106 properties, and (iii) be approved in writing by the Mobility Authority, at the Mobility Authority's sole discretion.

The DB Contractor shall be responsible for development of all necessary Antiquities Permits from the Texas Historic Commission (THC) required for Archeological Surveys of Additional Properties and areas outside of the Schematic ROW. The DB Contractor shall provide the Antiquities Permit application materials to the Mobility Authority for review and acceptance, prior to submittal to the THC by TxDOT for processing. The DB Contractor shall be responsible for development and implementation costs required to obtain necessary Antiquities Permits and Archeological Surveys associated with Additional Properties.

9.3.6.3 Cultural Resource Requirements During Construction

If evidence of archeological deposits is encountered during construction, the DB Contractor shall cease Work in the immediate area and contact the Mobility Authority. The Mobility Authority will then initiate discovery procedures under the provisions of the Programmatic Agreement and MOU between TxDOT and the THC. Work shall not be resumed in the area until the DB Contractor receives written notification and approval from the Mobility Authority.

9.3.7 Water Quality

The DB Contractor shall be responsible for conducting all construction in accordance with applicable Laws, pertaining to the minimization of impacts on water quality. The DB Contractor shall minimize impacts to water quality during construction through the implementation of a SW3P and WPAP and comply with

conditions of the 401 certification. Because of the potential effects of the Work on water quality, the DB Contractor shall include temporary and permanent storm water management measures in the design and construction of the Work.

The DB Contractor shall maintain all permanent and temporary controls as indicated in the SW3P, WPAP, and 401 certification and as required by the Mobility Authority and Governmental Entities. When the maintenance of facilities does not meet the satisfaction of the Mobility Authority or Governmental Entities, the DB Contractor shall immediately implement a corrective/restorative action. If the Work is not performed in a timely or effective manner to satisfaction of the Mobility Authority or the Governmental Entities, the Mobility Authority shall perform the necessary Work at the DB Contractor's expense.

Guidance documents, such as *Storm Water Management Guidelines for Construction Activities* (TxDOT publication) provide a detailed discussion of BMPs that are suitable for use during roadway construction. The succeeding sections outline the regulatory compliance and storm water management requirements.

The DB Contractor shall track all embankment and top soiled slopes left idle for more than 14 days, within or at the end of the 14-day idle period, to prevent erosion. Tracking consists of operating a tracked vehicle or equipment up and down the slope, leaving track marks perpendicular to the direction of the slope.

9.3.7.1 TPDES Construction General Permits

The DB Contractor shall comply with the TCEQ Storm Water Program regulations in accordance with the TPDES requirements as governed by TCEQ. The DB Contractor must prepare and submit a NOI and SW3P to the Mobility Authority for review and acceptance, and then submit the NOI to the TCEQ for coverage under the Construction General Permit for stormwater discharges from construction sites. The DB Contractor shall meet TPDES permit requirements by implementing approved erosion controls, sediment controls and post-construction Total Suspended Solids controls. The DB Contractor shall install temporary erosion controls, per the construction plans, prior to commencement of construction. The DB Contractor shall conduct regular inspections of temporary erosion controls and replace/maintain as needed.

The DB Contractor shall be responsible for the implementation of all provisions in the SW3P for the Work.

The DB Contractor shall be responsible for securing necessary approvals for the Work under the Municipal Separate Storm Sewer System (MS4) program of NPDES, if applicable.

9.3.7.2 Stormwater Management BMPs

The DB Contractor shall include the type and location of permanent water pollution control measures, if required, in the Final Design. These may include retention ponds, wet ponds, sand filters, and batch detention. Additionally, the DB Contractor shall prepare a plan for the proper and effective installation and use of temporary water pollution control measures to prevent avoidable water pollution during construction activities. The DB Contractor shall design the measures to meet the requirements in Mobility Authority-Provided Approvals and all Laws applicable to the TPDES Construction General Permits. The temporary

water pollution control BMP should be implemented as described in the SW3P for construction activities. Construction phase water quality BMPs could include the following:

- Temporary vegetation.
- Soil retention blankets/mats.
- Silt fences.
- Filter dams.
- Rock gabions.
- Water quality (detention) pond.

Such measures shall be subject to the acceptance by the Mobility Authority and approval by the TCEQ.

9.3.8 Groundwater Impacts and Requirements

If domestic water wells are encountered, the DB Contractor shall seal the well in accordance with TCEQ requirements under 30 TAC Chapter 213 and the Texas Department of Licensing and Regulation under 16 TAC Chapter 76 prior to any construction activity so that stormwater runoff from the project cannot use a well as an avenue for groundwater contamination. If potential contamination of the well or any other well near or in the Final ROW occurs, the DB Contractor shall notify the Mobility Authority and TCEQ within 24 hours of discovery and undertake appropriate measures to remediate the contamination. The DB Contractor shall be responsible for coordination with owner(s) of environmental monitoring wells with the intent to plug and abandon the wells within the Project ROW. The DB Contractor shall be responsible for all costs associated with sealing all known, as well as unknown wells, which may be encountered within the Final ROW.

9.3.9 Floodplain Encroachment

The DB Contractor shall design and construct the roadway and drainage facilities to minimize impacts on the 100-year floodplain elevation in accordance with the requirements of *Technical Provision 15*.

9.3.10 Jurisdictional Waters, Including Wetlands

The DB Contractor shall support the Mobility Authority in initiating any coordination, if required, with the USACE to determine the permitting and mitigation requirements for the Project under Section 404 of the Clean Water Act (CWA).

The DB Contractor shall be responsible for compliance with Nationwide Permit 14 conditions under Sections 401 and 404 of the CWA regarding permanent fill, temporary impacts, and potential surface water quality impacts for the Project. The DB Contractor shall be responsible for completion of Nationwide Permit 14 requirements under Section 404 of the CWA before construction activities begin in the impacted area. The DB Contractor shall conduct construction activities to avoid and minimize impacts to the stream

channels associated with vehicle crossings and temporary placement of fill. The Environmental Team (ET) shall pre-survey all stream crossing sites to identify and mark appropriate locations for any required temporary crossings to minimize impacts to the streams. The ET, under the direction of the ECM, shall identify and cordon off, with barrier or siltation fence, all jurisdictional wetlands (those associated with Shoal Creek) outside the active construction area. To the extent feasible, these areas shall be protected from impact by construction activity or run-off. The ECM and ET shall monitor construction activities and the DB Contractor shall maintain, repair, or replace any barrier or siltation fencing disturbed during construction activities and provide additional fencing or protections necessary to preserve these resources. The ECM and ET shall monitor construction areas to verify that BMPs are being implemented as required. If required, work pads and/or temporary crossings at Lake Creek, Shoal Creek, and the tributary to Shoal Creek shall consist of 3-x-5-inch- (or larger) rock anchored with a perimeter boundary of concrete traffic barrier.

9.3.10.1 Wetlands Delineation

If changes to the Schematic Plans initiated by the DB Contractor result in impacts to areas outside of the Schematic ROW described in Mobility Authority-Provided Approvals, a field determination of jurisdictional waters will be required for all Additional Properties, as well as the DB Contractor's staging areas, field office sites, borrow sites, and stockpile locations. Similarly, the DB Contractor will be responsible for performing wetland field investigation in accordance with the USACE 1987 *Wetlands Delineation Manual* and USACE regional supplements, to determine whether jurisdictional wetlands exist on the Additional Property described above. If wetlands are identified, the DB Contractor shall delineate and record them using the USACE's Routine Wetlands Delineation Data Forms. The DB Contractor shall include jurisdictional wetlands on the delineation maps and determine the amount of temporary and permanent impacts as a result of the Work. The DB Contractor will be responsible for all costs associated with surveying and coordination for Governmental Approvals required as a result of design changes initiated by the DB Contractor.

9.3.10.2 Mitigation Requirements

The DB Contractor will be responsible for all costs, coordination, management, and monitoring for the Section 404 permit conditions and mitigation requirements. Mitigation of impacts to jurisdictional waters shall be accomplished following the guidance of *Section 404(h)(1)* of the CWA to avoid impacts wherever possible during Work, and to minimize and mitigate unavoidable impacts. The DB Contractor is responsible for mitigation of additional impacts arising from any changes to the Schematic Plan subsequent to the Environmental Documents approval.

9.3.11 Geology and Karst Features

In the event unknown karst voids, caves, solution cavities, groundwater, or wells are discovered during construction, all Work shall immediately be stopped in the vicinity of the feature. Regulated activity is not allowed

within 50 feet of an encountered sensitive feature until the DB Contractor prepares a TCEQ Encountered Feature Mitigation Plan (EFMP) for submission to TCEQ and approval is obtained.

If a sensitive feature is discovered during the Work, the DB Contractor shall immediately notify the Mobility Authority. The DB Contractor shall immediately notify TCEQ of the encountered sensitive feature at the direction of the Mobility Authority.

The DB Contractor shall provide a Licensed Professional Geoscientist to evaluate and document the feature who is qualified according to TCEQ requirements for a geologist as described in Section II, General Instructions, of the *Instructions to Geologists for Geologic Assessments on the Edwards Aquifer Recharge/Transition Zones*, found at:

https://www.tceq.texas.gov/assets/public/compliance/field_ops/eapp/F-0585_geologic_assessment_instructions.pdf

The DB Contractor shall ensure that a TCEQ EFMP is prepared, submitted to and approved by TCEQ.

The DB Contractor shall comply with the approved EFMP. Regulated activity may not commence until the EFMP is fully implemented and mitigation measures are completed.

Table 9-2: Environmental Feature Mitigation Plan Time Frames: Deliverable Schedule

Task	Description	Deliverable	Due Date
1	Environmental Training of On-site Personnel	Draft	
		Final	
2	Void Inspection and Monitoring	Monthly Reports	By the 5 th day of each month following NTP2
	Karst Technical Reports	Draft	After logical gaps in fieldwork or at least twice per year, June 15 and December 15
		Final	Two weeks after receipt of the State’s comments
3	Prepare Void Closure Plans and Coordinate with TCEQ	Void Sensitivity Determination and Notification	Complete the sensitivity determination within 24 hours of when a void is reported or is discovered during down-hole camera operations. Notify the State immediately upon determination of a sensitive feature.
		Draft Void Closure Plan	Within 4 days of the Void Sensitivity Determination unless otherwise directed by the State
		Revised Void Closure Plan	Within 1 day of receiving requested revisions from the State
		Response to TCEQ RFI	Respond to TCEQ within 3 days of receipt of a TCEQ RFI unless otherwise directed by the State.
		Final Void Closure Plan	Within 1 day of receipt of an approved Void Closure Plan

If karst voids or caves are discovered during the Work, the DB Contractor shall provide a qualified Karst Species Specialist recognized by the USFWS as expert on Threatened and Endangered karst invertebrate species for investigation of voids and caves discovered during construction in accordance with Technical Provision 9.3.5.2.

If it is determined that conditions are not favorable for the occurrence of Endangered Species, the DB Contractor shall fill and seal the void according to TCEQ procedures so as not to allow or promote groundwater contamination. If it is determined that conditions are favorable for the occurrence of Endangered Species, the DB Contractor shall initiate the pre-construction survey procedures as identified under Technical Provision 9.3.5.2. Survey results shall be presented to the Mobility Authority. The Mobility Authority will determine the necessary and appropriate level of coordination and may direct the DB Contractor to provide documentation to Governmental Entities. As noted in Technical Provision 9.3.5.2, the proximity of Critical Habitat for the Jollyville Plateau salamander and the potential for encountering karst formations providing habitat to five other federally Protected Species is currently the subject of Formal Consultation with the USFWS under Section 7 of the ESA. The DB Contractor shall implement mitigation measures required for the project as a result of Section 7 Consultation.

9.3.12 Edwards Aquifer Rules

The DB Contractor shall complete and implement a TCEQ-approved WPAP, which would authorize discharges over the Edwards Aquifer recharge zone from the Project during and after construction. The DB Contractor shall prepare and submit the WPAP to the Mobility Authority and TCEQ for review and approval prior to commencement of construction. In addition to temporary water quality BMPs, such as those referred to above, the WPAP will identify permanent water quality controls to be implemented with the Project. Except in the area between Hunters Chase and McNeil Drive, the permanent controls will be designed to achieve at least an 80 percent reduction in the increased Total Suspended Solids load discharging from the improved facility. In the area between Hunters Chase and McNeil Drive, controls will be designed to achieve at least an 85 percent reduction. The DB Contractor has the option to meet the Edwards Aquifer Rules requirements through multiple WPAPs rather than a single WPAP for the entire Project.

9.4 Environmental Monitoring and Reporting

9.4.1 General Monitoring/Reporting Requirements

The DB Contractor shall monitor and document field activities for compliance with the environmental requirements of Mobility Authority-Provided Approvals, Environmental Approvals, applicable Law, and the Contract Documents. Monitoring reports shall be submitted to the Mobility Authority weekly.

9.4.1.1 *Pertinent Applications*

The requirements of this *Technical Provision 9.4* apply to all the DB Contractor's field activities conducted in association with the Work and Additional Properties, including but not limited to, surveys, borings, concrete or asphalt batch plants, staging, equipment storage, employee parking, and field offices. These requirements apply to activities conducted on land that is purchased, leased, occupied, or used by the DB Contractor under any other type of land-use agreement as well as on property owned by the Mobility Authority or the State of Texas.

9.4.1.2 *Reporting Format*

The DB Contractor shall provide weekly Environmental Monitoring Reports (EMRs) to the Mobility Authority, as described in the following sections. The EMRs shall be in a format that minimizes the amount of paper used and can be interpreted quickly and must include the following minimum information:

- Type of resource(s) addressed by EMR (vegetation, water quality, air quality, etc.).
- Location of area monitored (map, stationing, etc.); or, if not within the Schematic ROW, a location map that clearly illustrates the spatial relationship of the Additional Property to the ROW.
- Name of inspector or monitor.
- Date monitoring occurred.
- Locations and nature of violations, if any.
- Recommended remedial actions, if any.
- Weather conditions.

9.4.1.3 *Reporting Contact Tree*

Contact Information. Within 30 days after NTP 1, the DB Contractor shall submit to the Mobility Authority an outline or flow chart of all contact and reporting requirements for any environmental conditions encountered during the course of the Work.

The reporting contact tree shall include contacts for the DB Contractor, the Mobility Authority, and Governmental Entities; shall outline the chain of contacts; and shall be formatted such that it is clear to every employee which contacts shall be notified to report unforeseen impacts to Hazardous Materials or environmental/cultural resources.

The reporting contact tree shall include for each contact the person's name, agency or corporate affiliation, address, e-mail address, telephone number(s), and fax number.

Conditions To Be Reported. The reporting contact tree shall include, at a minimum, appropriate contacts and reports for the following conditions:

- Contractor-caused spill - Reportable quantity spill, as defined by 30 TAC 327 (and 30 TAC 334 for petroleum storage tank spills into water).
- Discharge of groundwater.
- Discovery of active bird nest (with eggs or young), if discovery confirmed outside nesting season.
- Discovery of artifacts, dwellings, structures, or other items of potential historical importance.
- Discovery of hazardous substances or contaminated materials.
- Discovery of human bones or remains.
- Discovery of karst voids or caves.
- Discovery of wildlife injured during construction activities.
- Discovery or Disturbance of any Threatened or Endangered Species or habitat of said species.
- Violation of Section 401 Water Quality Certification.
- TPDES inspections.
- Violation of Section 402 TPDES permit(s).
- Other SW3P issues not covered above.
- Violation of Section 404 permit.
- Work in streams or wetlands.
- Work outside planned Final ROW.

9.4.1.4 Reporting of Violations

If violations of any environmental requirements or conditions of Laws, Rules, or Environmental Approvals are included in a report, the DB Contractor shall immediately notify the Mobility Authority electronically, verbally, and in writing. The Mobility Authority will coordinate notification of the appropriate Governmental Entity as necessary. The actual report need not be included in the notification, but should be readily available to the Mobility Authority. For purposes of this section, a violation includes any breach of an environmental requirement, regardless of whether a notice of violation has been delivered to the DB Contractor.

Governmental Entity Coordination. The DB Contractor shall be available to meet with the Governmental Entities at the direction of the Mobility Authority within 30 days after NTP 1 and then periodically to maintain compliance with environmental requirements.

9.5 Environmental Protection Training

The Mobility Authority is committed to completing the Project with minimal impact on environmental resources. To this end, the DB Contractor shall develop and implement an Environmental Protection Training Program that will meet the minimum requirements set forth herein. The DB Contractor's program to achieve the environmental commitments of the Project as discussed herein will be strengthened by implementation of a successful Environmental Protection Training Program.

Non-employees. Although this training program is directed toward the DB Contractor's employees and Subcontractors, including truck drivers and equipment operators, the DB Contractor shall be responsible for all actions of any persons working on the Project site who do not comply with the environmental protection requirements of this *Technical Provision 9*.

9.5.1 Training Goals

The Mobility Authority has identified the following goals of the Environmental Protection Training Program:

- Comply with all local, Federal, and State Environmental Laws.
- Achieve all environmental commitments set forth in Mobility Authority-Provided Approvals and Environmental Approvals.
- Educate every worker to:
 - Recognize the overall importance of environmental issues to achieving a successful Project.
 - Appreciate the various environmental sensitivities of the Project.
- Train every worker to:
 - Recognize environmentally sensitive resources that may be encountered during construction of the Work, with a focus on karstic voids.
 - Avoid or take appropriate action to minimize environmental impacts from the Work.
 - Know the required actions, practices, and procedures regarding regulated resources.
- Foster the DB Contractor's management and supervisory personnel's attitude of commitment to the Project's environmental quality.
- Convey the DB Contractor's management commitment to the Project's environmental quality to all workers.

- Convey the Mobility Authority's and the DB Contractor's commitment to zero tolerance for violations.

9.5.2 Training Scope and Content

Under the direction of the ECM, the environmental training staff shall develop, schedule and conduct environmental awareness and environmental compliance training for all of the DB Contractor's personnel, including subcontractors.

The DB Contractor may solicit input from the Mobility Authority regarding Project environmental quality for the Environmental Protection Training Program. The Mobility Authority staff will be available to provide assistance regarding the Mobility Authority's environmental goals, policies, and its oversight of the DB Contractor's environmental component of the CMP. The Mobility Authority may make certain materials available to the DB Contractor for use in conducting the Environmental Protection Training Program.

Training Topics. The Environmental Protection Training Program shall, at a minimum, include all of the following topics.

- Background on environmental issues.
- Overview of specific environmental commitments at the project level.
- The overall importance of environmental protection to the Project.
- DB Contractor's commitments and responsibilities.
- Worker responsibilities.
- Regulatory permit conditions.
- Wetlands identification.
- Overview of the provisions of the Endangered Species Act and Project mitigation commitments.
- BMPs for environmental compliance, including but not limited to pollution prevention, erosion, sedimentation, and dust control measures to maintain water and air quality.
- Required mitigation measures.
- Compliance responsibility and Governmental Entity authority.
- Procedures and precautions in the event of spills of or discovery of Hazardous Materials or unknown chemicals or contamination.
- Procedures and precautions in the event skeletal remains or other archeological or paleontological resources are discovered.
- Procedures and precautions in the event of karst void/cave discovery.

- Groundwater protection requirements.
- CWA regulations and surface water protection requirements.
- Overview of noise and residential impact reduction procedures.
- Air quality and dust control requirements.
- Penalties and/or fines for violations of and noncompliance with environmental requirements and Laws, including termination of employment.
- Each worker must receive at least one hour of karst discovery and mitigation training from the DB Contractor before performing any work at the Project Site.

9.5.3 Participation and Responsibilities

The Mobility Authority expects that each and every DB Contractor employee (including new employees beginning after Work commencement) and the DB Contractor's Subcontractors shall actively participate in the Environmental Protection Training Program and will conduct the Work in a manner that is consistent with achieving minimal environmental impact. The DB Contractor shall require all Work staff (from management through workers) to participate in the Environmental Protection Training Program.

Environmental staff responsibilities, including those of the ECM, shall be as set forth in *Technical Provision 9.6*. The DB Contractor's management and supervisory personnel shall develop and foster attitudes and policies that are conducive to all workers conducting the Work in a manner that recognizes and respects the importance of and commitment to environmental protection.

9.5.4 Training Schedule

The DB Contractor shall include a schedule for implementation of the Environmental Protection Training Program in the Project Schedule. The length of training sessions and their frequency shall be sufficient to achieve the goals set forth above. Periodic training sessions at key times (e.g., prior to construction in sensitive areas or construction timing restrictions to protect Threatened and Endangered Species) may be used to update workers on specific restrictions, conditions, concerns, or requirements.

9.5.4.1 Introductory Training

The DB Contractor shall provide introductory environmental protection training to all personnel who will be performing Work at the Project site. Each person (including newly hired employees) shall be required to complete the introductory training prior to arriving at the Site. The introductory training shall be of sufficient detail to provide an understanding of the Project's environmental goals, commitments, issues, restrictions, and construction limitations. The training session shall be comprehensive regarding the breadth of environmental issues. The in-office training session(s) should include the DB Contractor's management commitment to environmental quality.

The DB Contractor shall provide training for employees who begin Work between regularly scheduled training sessions, such as a comprehensive training video that provides details on environmental issues of concern, the environmental contact tree, and guidelines for disciplinary actions and termination. The DB Contractor shall institute a mechanism whereby the training status of each employee will be readily apparent (such as stickers on hard hats that indicate the level(s) of training received). The DB Contractor shall also maintain records of employee training and provide such records to the Mobility Authority upon request.

9.5.4.2 Ongoing Training

The DB Contractor shall schedule periodic “toolbox” training sessions to provide workers with updated information on key issues, foster an attitude of protecting environmental resources, recognize and award environmental achievers and award recipients, and convey the Mobility Authority and the DB Contractor management teams' serious regard for environmental quality and compliance.

9.5.5 Training Documentation

The DB Contractor's ECM shall maintain documentation regarding participation in the Environmental Protection Training Program and the attendees' understanding of the information presented. This information should be included in monthly reports submitted to the Mobility Authority. The DB Contractor shall record and report to the Mobility Authority attendance at each training session, and shall monitor attendance and provide timely opportunities for workers to make up any required sessions that are missed.

Verification Testing. The DB Contractor shall develop methods to verify to the Mobility Authority the success of the Environmental Protection Training Program.

9.6 Environmental Personnel

9.6.1 Environmental Personnel

The DB Contractor shall designate an independent Environmental Team (ET), as detailed in this *Technical Provision 9.6*, to prevent, minimize, and/or correct any violation of or noncompliance with environmental requirements. The DB Contractor shall be accountable for the decisions by the ET, as related to violations of or noncompliance with Environmental Laws, agreements, orders, the RFDP, Proposal, or Contract Documents. The ET shall include the ECM, Environmental Training Staff, Environmental Compliance Inspectors (ECIs), as well as the natural resource biologist, Project geologist, water quality specialist, and Hazardous Materials manager.

To ensure objectivity, the ET, and specifically the ECM, shall report directly to the Mobility Authority and the DB Contractor. Once the ET has been designated, the DB Contractor shall not have the ability or authority to relieve any designated ET member from his or her designated duty without the express written consent of the Mobility Authority.

If a violation or a noncompliance situation occurs, the ET shall be responsible for coordinating with the DB Contractor's on-site personnel to minimize its impacts on human health or the environment to the extent practicable.

9.6.2 Environmental Compliance Manager

The DB Contractor shall designate an independent ECM for the Work. The independent ECM is considered to be one of the Key Personnel. To ensure objectivity, the ECM shall report directly to both the Mobility Authority and the DB Contractor. The Mobility Authority may elect to appoint an Independent ECM to oversee project delivery, including having stop work authority over construction activities. The DB Contractor shall not have the ability to relieve ECM of his or her duty without the express written consent of the Mobility Authority.

9.6.2.1 ECM Responsibilities

The ECM shall monitor, document, and report environmental compliance for the Work as required by the Contract Documents. The ECM shall prepare a Construction Monitoring Plan (CMP) and submit said plan to the Mobility Authority for approval 20 Days after issuance of NTP 1. The CMP shall indicate times, locations, and other conditions where monitoring of construction activities are to be performed to maintain and ensure compliance with Environmental Laws and Contract Documents. The CMP shall be updated and submitted to the Mobility Authority and the DB Contractor for review on a monthly basis.

Environmental Monitoring Program. The ECM shall have overall responsibility for the Environmental Monitoring Program. Refer to Technical Provision 9.4 for minimum environmental monitoring requirements.

Personnel Selection. The ECM shall designate personnel knowledgeable in the various environmental subject areas to provide the necessary environmental expertise required for the Work and to conduct environmental protection training. The rationale for the selection of the training staff shall be set forth in the Contract Documents and modified as needed to reflect any additional Mobility Authority requirements. Selection of the training staff must be in accordance with the criteria approved by the Mobility Authority. The Mobility Authority will maintain the right and authority to approve or reject any or all environmental staff.

Direction of Work and Reports. The ECM shall direct the Work of the environmental staff as set forth herein.

9.6.2.2 ECM Authority

Order to Remedy. The ECM shall have the authority to remedy violations of, or noncompliance with, environmental requirements set forth in Laws, Rules, and Environmental Approvals. If the event poses imminent danger to human health or the environment, these remedies shall be invoked immediately upon discovery. For other events, the ECM shall consult with the Mobility Authority and appropriate

Governmental Entities to minimize the impacts of the violation or noncompliance on human health or the environment.

Stop Work. All members of the ET and the Mobility Authority, shall each have the authority to stop Work as required to eliminate or prevent violations of environmental requirements without fear of reprisals. This Work stoppage should be limited to the immediate vicinity or area affected by the event that represents an imminent danger to human health or the environment. At the first available moment, the Mobility Authority and the DB Contractor shall be apprised of the event. The Mobility Authority retains the authority to order a Work stoppage within the entire Project area for DB Contractor non-compliance with environmental commitments in the Environmental Documents, permits, Environmental Laws or other Environmental Approvals.

The ECM shall have, and shall exercise, the authority to prevent and remedy violations of environmental requirements. Additionally, the ECM shall have the authority to direct the DB Contractor to implement measures to minimize future violations of Environmental Laws, agreements, applicable Law and the Contract Documents.

9.6.2.3 *Environmental Training Staff*

The ECM shall be responsible for assigning qualified personnel to the Environmental Training Staff and also coordinating training sessions with Governmental Entities as necessary. The Environmental Training Staff shall train and educate the Environmental Compliance Inspectors (ECIs), as described in *Technical Provision 9.6.3* sufficiently to allow the efficient and effective performance of their duties, as required by Environmental Laws, agreements, Rules and the Contract Documents. This ECI training program will be in accordance with the requirements set forth in *Technical Provision 9.5*. Environmental training staff members shall have at least one year of experience providing environmental compliance inspection for highway construction.

9.6.2.4 *Coordination with Governmental Agencies*

The ECM shall coordinate with the Mobility Authority, the DB Contractor, and, when directed by the Mobility Authority, appropriate Governmental Entities (including, but not limited to, the USACE, OSHA, TCEQ, NRCS and USFWS). At the direction of the Mobility Authority, the ECM shall submit all necessary environmental documentation and monitoring reports to the appropriate Governmental Entities to maintain compliance with applicable Laws and Environmental Approvals.

9.6.2.5 *Documentation and Reports*

The ECM shall prepare status reports to the Mobility Authority summarizing all environmental Work. The ECM shall also submit reports as required by Environmental Laws, agreements, Rules and Contract Documents.

Weekly Reports. A minimum of one EMR per week is to be submitted to the Mobility Authority on the status of the Work as it relates to environmental commitments and detailing the results of the Environmental Monitoring Program for the subject period. Items to be included in the report include, but are not limited to, a summary of violations of or noncompliance with Environmental Laws, agreements, permits, orders or the Contract Documents, and measures taken to eliminate, prevent, remediate and minimize environmental impacts.

9.6.3 ECI Responsibilities

The ECIs shall provide on-site compliance monitoring of the Work under direction of the ECM. Neither the DB Contractor nor the ECM shall have the ability or authority to relieve an ECI of his/her duty without the express written consent of the Mobility Authority. The ECM shall be responsible for conducting appropriate training sessions for all ECIs, prior to commencement of compliance monitoring activities.

The ECIs shall be responsible for conducting on-site monitoring, preparing documentation, and reporting violations or noncompliance with Environmental Laws, permits, agreements, orders, or the Contract Documents. The daily written reports shall include violations and noncompliance, as well as documenting compliance. The daily monitoring reports shall be submitted to the ECM.

Additionally, the ECIs shall have the authority to stop Work on the Project if the Work should represent an imminent danger to human health or the environment, without fear of reprisals. This Work stoppage should be limited to the immediate vicinity or area affected by the event that represents the danger. The ECI will immediately notify the ECM of the situation and the ECM will notify the Mobility Authority and the DB Contractor, and then proceed to the site of Work stoppage.

9.6.4 Karst Species Specialist

The ECM shall designate a USFWS-permitted Karst Species Specialist to determine if a potential karst feature meets the criteria for a sensitive feature.

Qualifications. The Karst Species Specialist shall be a qualified and experienced professional with experience in similar projects. Qualifications, knowledge, and experience should include:

- USFWS Section 10(a)(1)(A) Scientific-permitted for JPS and Karst species.
- Bachelor's degree in biology, geology, or related natural science field.
- Ability to determine if a potential karst feature has the potential to contain suitable habitat for endangered karst invertebrates or if the karst feature could open up into another karst feature with such suitable habitat.
- Ability to conduct determinations of karst features for the presence or absence of endangered karst invertebrates throughout the course of the Work.
- Construction techniques in general.

- Monitoring of construction jobs.
- Applicable Environmental Laws, agreements, Rules, and the Contract Documents.
- Applicable training modules discussed herein Technical Provision 9.5.2.

Availability. The Karst Species Specialist shall be available to be on-Site within 4 hours of discovery of any karst features. The DB Contractor shall identify a secondary contact for karst species concerns in case the primary Karst Species Specialist is unable to respond to the Site. The secondary contact should be included on the environmental contact tree and should also meet the criteria listed above.

9.6.5 Natural Resource Biologist

A Natural Resource Biologist shall be designated by the ECM to provide expertise in monitoring impacts on wildlife and the natural environment due to construction activities related to the Work.

Qualifications. The Natural Resource Biologist shall be a qualified and experienced professional with experience in similar projects. Qualifications, knowledge, and experience should include:

- Applicable Environmental Laws, agreements, Rules, and the Contract Documents.
- Applicable training modules discussed herein Technical Provision 9.5.2, including completion.
- Wildlife management and protection in the State.
- ESA.
- USFWS Section 10(a)(1)(A) Scientific-permitted for JPS and Karst species.
- Knowledge of Threatened and Endangered Species found within the Project region.
- Natural resource management and protection in Texas.
- Sections 401, 402, and 404 of the CWA.
- Construction techniques in general.
- Monitoring of construction jobs.
- Bachelor's degree in ecology or related biological field (i.e., wildlife biology, botany, etc.).
- Shall have 5 years of work experience in an environmental consulting or management field will be required.

Availability. The Natural Resource Biologist shall be available to be on-Site within 4 hours at any time construction activities are being conducted. The DB Contractor shall identify a secondary contact for natural resource concerns in case the primary Natural Resource Biologist is unable to respond to the Site. The secondary contact should be included on the environmental contact tree and should also meet the criteria listed above.

9.6.6 Project Geoscientist

The DB Contractor shall provide a Licensed Professional Geoscientist with expertise and knowledge of TCEQ Edwards Aquifer void mitigation requirements for investigation of voids and caves discovered during construction in accordance with Technical Provision 9.3.5.2.

The ECM shall designate a Licensed Professional Geoscientist for the course of the Work to assist the karst species specialist in determining if a potential karst feature meets the criteria for a sensitive feature.

The Licensed Professional Geoscientist assists the Permitted Karst Species Specialist in assessing the potential for a karst feature to contain suitable habitat for endangered karst invertebrates or if the karst feature could open up into another karst feature with such suitable habitat.

The Licensed Professional Geoscientist prepares Encountered Feature Mitigation Plans and signs/seals the mitigation plan.

The Licensed Professional Geoscientist shall provide expertise in the development and implementation of the WPAP.

The Licensed Professional Geoscientist shall meet the certification requirements of TxDOT Work Category 2.5.1, “Geological Assessment for Edwards Aquifer Recharge Zone.”

The Project Geoscientist shall be available to be on-site within 4 hours at any time construction activities are being conducted. The DB Contractor shall identify a secondary contact for in case the primary Project Geoscientist is unable to respond to the Project site. The secondary contact should be included on the environmental contact tree and should also meet the criteria listed above.

9.6.7 Water Quality Specialist

A Water Quality Specialist shall be designated by the ECM to provide expertise in permitting delineation and the protection of jurisdictional waters under the regulations of the CWA, Sections 401, 402, and 404, as implemented in the State of Texas through USACE, EPA, and TCEQ programs, during the course of the Work.

Qualifications. The Water Quality Specialist shall be a qualified and experienced professional with experience in similar projects. Knowledge and experience should include:

- Wetlands and riparian management and protection in Texas.
- The ecology of riparian ecosystems.
- CWA Sections 401 and 404 and/or supporting documentation for temporary or permanent impacts to jurisdictional waters within the Proposed ROW.

- CWA Section 402 TPDES provisions for construction and permanent storm water management.
- Familiarity and expertise with TCEQ Edwards Aquifer Rules and regulations.
- Construction techniques in general.
- Monitoring of construction jobs.
- Applicable Environmental Laws, agreements, Rules, and the Contract Documents.
- Applicable training modules discussed herein *Technical Provision 9.5*, including completion.

Availability. The Water Quality Specialist shall be available to be on-Site within 4 hours at any time construction activities are being conducted. The DB Contractor shall identify a secondary contact for natural resource concerns in case the primary Water Quality Specialist is unable to respond to the Site. The secondary contact should be included on the environmental contact tree and should also meet the criteria listed above.

9.6.8 Hazardous Materials Manager

The ECM shall designate a Hazardous Materials Manager to provide expertise in the safe handling of Hazardous Materials required to perform the Work and those that may be discovered/impacted during construction, see *Technical Provision 9.3.2*. The Hazardous Materials Manager shall be a Registered Professional Engineer or a Licensed Professional Geoscientist, familiar with applicable Laws and TCEQ guidance for the investigation and remediation of Hazardous Materials under the TCEQ *Voluntary Cleanup Program and Texas Risk Reduction Program Rules*. Additionally, the Hazardous Materials Manager shall be responsible for scheduling and/or conducting training for the DB Contractor's employees.

All personnel of the DB Contractor and Subcontractors handling Hazardous Materials shall be trained and certified at least to the minimum requirements established under the guidelines of *OSHA 1910.120* (HAZWOPER Training) and must be enrolled and cleared by a medical surveillance program prior to engaging and after completion of Work activities. The Hazardous Materials Manager, to ensure that personnel have met the minimum *OSHA 1910.120* guidelines, will be 40-hour HAZWOPER certified and shall review all employee certificates prior to any handling of Hazardous Materials.

The DB Contractor shall ensure that all applicable certifications, licenses, authorizations and Governmental Approvals of the DB Contractor, Subcontractors and any other workers on the Work are current and valid through the duration of the Work.

The DB Contractor shall make all on-Site workers aware of the potential Hazardous Materials to which they may be exposed, shall limit Subcontractors and other site workers' exposure to Hazardous Materials and provide all necessary personal protection equipment to protect them from exposure.

The Hazardous Materials Manager shall maintain records of all incidents involving Hazardous Materials or hazardous waste and notify the ECM, Mobility Authority and appropriate State authorities in writing of any such incidents on a weekly basis in accordance with Technical Provision 9.4.

Qualifications. The Hazardous Materials Manager shall be a qualified and experienced professional with experience in similar projects. Assessment criteria to be used in evaluating candidates for the Hazardous Materials Manager include, but are not limited to, the following specific knowledge and experience:

- Registered Professional Engineer or Licensed Professional Geoscientist.
- Shall have 5 years' experience with similar type projects.
- Experience in developing IWPs, SIRs, and Remedial Action Plans or equivalent reports necessary and acceptable to the TCEQ in material discovery and remediation efforts of Hazardous Materials or wastes.
- Construction techniques in general.
- Monitoring of construction jobs.
- Applicable Environmental Laws, agreements, Rules, and the Contract Documents.
- Applicable training modules discussed herein Technical Provision 9.5.2, including completion.

Availability. The Hazardous Materials Manager shall be available to be on-Site within 2 hours at any time construction activities are being conducted. The DB Contractor shall identify a secondary contact for natural resource concerns in case the primary Hazardous Materials Manager is unable to respond to the Site. The secondary contact should be included on the environmental contact tree and should also meet the criteria listed above.

9.7 Submittals

The DB Contractor shall be responsible for the following submittals, at a minimum, to the Mobility Authority and to Governmental Entities as directed by the Mobility Authority and required by the Contract Documents and Environmental Approvals:

- CMP, as required by Technical Provision 9.4.
- Environmental contact tree.
- Environmental Monitoring Reports.
- IWPs, SIRs, and Remedial Action Plans as necessary for hazardous material discovery/remediation.
- Wetlands Delineations and appropriate Section 404 Permit Application if changes to the design or temporary construction impacts are necessary.

- Mitigation or resource monitoring reports, as required by resource-specific mitigation plans, including the Encountered Feature Mitigation Plan.
- Preparation and submittal of additional plans and reports as identified in Mobility Authority-Provided Approvals, the DB Contractor secured Governmental Approvals and resource-specific mitigation plans.
- The schedule for submittals will be in accordance with the requirements set forth previously in these *Technical Provisions* or as necessary to maintain compliance with all applicable Laws, Rules, and Environmental Approvals granted for the Work.

Table 9-3: Submittals to Mobility Authority

Submittals	Submittal Schedule	Mobility Authority Action	Reference Section
Application for Environmental Approvals	As needed	Review and Approve	9.2.3
Hazardous Material Management Plan	1. 90 days after NTP 1 & 2. updated monthly or as directed by Mobility Authority	Review, approve & comment	9.3.2
IWP	Prior to implementing fieldwork activity	Review	9.3.2.3
SIR	Upon satisfactorily completing the IWP	Review	9.3.2.3
Noise Analysis	As needed	Review	9.3.3.2
Wildlife and Vegetation Survey	As needed	Review	9.3.5
Threatened and Endangered Species Survey	As needed	Review	9.3.5.2
Cultural Resource Pre-Survey Report	Prior to the initiation of any construction activities on Additional Properties	Information	9.3.6.2
Antiquities Permit	Prior to Submittal to the THC	Review & Acceptance	9.3.6.2
NOI	NTP 1	Review & Acceptance	9.3.7.1
SW3P	NTP 1	Review & Acceptance	9.3.7.1

Table 9-3: Submittals to Mobility Authority

Submittals	Submittal Schedule	Mobility Authority Action	Reference Section
404 Permit/Mitigation Plan	As needed, prior to initiation of any construction activities within impacted jurisdictional waters	Review & Acceptance	9.3.10, 9.3.10.2
Encountered Feature Mitigation Plan	As needed	Review & Acceptance	9.3.11
WPAP	Prior to Commencement of Construction	Review & Approval	9.3.12
Environmental monitoring reports	Weekly	For information	9.4.1.2
Reporting Contact Tree	30 Days from NTP 1	Information	9.4.1.3
Records of Employee Training	Upon Request	Information	9.5.4.1
Construction Monitoring Plan (CMP)	20 days after NTP 1	Approval	9.6.2.1
EMR	Weekly	Information	9.6.2.5

10.0 LANDSCAPE AND AESTHETICS

10.1 General Purpose

The DB Contractor shall be responsible for landscape and aesthetics in accordance with the requirements identified in this Technical Provision 10 and Exhibit C – Attachment 10-1 – 183 North Mobility Project Aesthetic Design Guide and directives herein. In the absence of specific criteria herein, the Project Design shall conform to applicable standards and criteria of TxDOT, AASHTO, and FHWA.

The landscape and aesthetic components presented in Exhibit C – Attachment 10-1 – 183 North Mobility Project Aesthetic Design Guide include:

- Aesthetics Plan Matrix
- Color Palette
- Cross Street Overpass Bridge Widening, Infill & Cladding of Existing Columns to Remain
- Decorative End Column – Cross-Street Overpass Structures
- Loop 1 / US 183 Direct Connector Bridges
- Major Guide Sign/ITS Support Structures
- Toll Gantry Support Structures
- Toll Gantry Cladding, Signing and Branding
- Column Sizes and Reveal Placement Details
- Decorative Column Cap Details
- Standard Bent Cap Details
- Mast Lighting Tower Base Details
- Retaining Wall Texture Patterns
- Retaining Wall Details
- Vehicle Safety Barriers
- Storm Water Basin Fencing
- Special Interchange Median Pavement
- SUP Special Pavement
- SUP Overhead Art
- Corridor Concept Landscape Plan

- Cross-Street Interchange Plantings
- Screen Plantings at select Storm Drainage Facilities
- Sound Walls

Additional requirements found in these *Technical Provisions* that are not covered in *Exhibit C – Attachment 10-1 – 183 North Mobility Project Aesthetic Design Guide* include the following:

- Quality Management During Design
- Construction Quality Management
- Warranty Specifications
- Environmental Compliance
- Bridges and Highway Structural Design
- Permanent Signing Design
- Drainage and Grading Design
- Aesthetic Lighting Design
- MOT Design Criteria
- Construction
- Maintenance and Establishment
- Sustainability
- Preservation and Repair of Areas to be Preserved
- Revegetation
- General Scope Requirements

Following the technical design guidance and coordination with other reference documents outlined above, the DB Contractor shall submit preliminary aesthetic design plans for elements as described below to Mobility Authority for review and comment prior to or in conjunction with the Preliminary (30%) Design Submittal and the Intermediate (65%) Design Submittal. The Mobility Authority will not accept any Early Release for Construction or Release for Construction packages which include aesthetic components until the DB Contractor has resolved all comments to the Mobility Authority’s satisfaction.

Areas less than 10 feet in width shall be treated in accordance *Exhibit C – Attachment 10-1 – 183 North Mobility Project Aesthetic Design Guide* and Technical Provision 10.16.1. The following design criteria along with *Exhibit C – Attachment 10-1 – 183 North Mobility Project Aesthetic Design Guide* define the baseline aesthetic treatments for the Project. Any deviation from these guidelines will require Mobility Authority approval.

10.2 Aesthetic Matrix and Color Palette

The aesthetic matrix and color palette identify the aesthetic treatments, including coatings, color, textures, and where applicable special materials shall meet requirements found in Exhibit C – Attachment 10-1 – 183 North Mobility Project Aesthetic Design Guide.

10.3 Bridge Components

Bridges, both existing to remain and new bridge structures shall meet the aesthetic requirements (form, texture, color and details as indicated in Exhibit C – Attachment 10-1 – 183 North Mobility Project Aesthetic Design Guide.

The DB Contractor shall comply with the following requirements:

- For steel superstructures, use continuous spans with a minimum number of expansion joints; and for conventional concrete superstructures, use simple spans. Steel superstructure shall incorporate necessary flashing to minimize staining of surrounding concrete.
- Locate columns under new structures, new decorative end columns or cladding of existing columns parallel and in common line to the existing bridges at each bent.
- Bent caps on new/widened bridges placed next to existing shall have the same shape when viewed in elevation as the existing bent caps. The bottom chord alignment on bridges shall be maintained as a continuous line.
- Mixing of dissimilar girder depths within a bridge structure will not be allowed except as follows: At the CD connector bridges one shift in girder depth will allowed to facilitate span requirements with the review and approval of the Mobility Authority.

10.4 Retaining Walls

Retaining wall appearance shall meet requirements found in Exhibit C – Attachment 10-1 – 183 North Mobility Project Aesthetic Design Guide.

. In addition, the DB Contractor shall comply with the following requirements:

- Retaining Wall alignments, profile, and layouts shall be included in the Intermediate (65%) Design Submittal. The DB Contractor shall minimize the visual impacts of all walls in the Work by:
 - Utilizing wall profiles and alignments that blend with the natural terrain.
 - Unless otherwise indicated, all wall types shall have consistent finish, texture and appearance and shall be approved by the Mobility Authority.

- Customizing the grading to reduce the need for retaining walls while meeting the wall design requirements set forth in Exhibit C – Attachment 10-1 – 183 North Mobility Project Aesthetic Design Guide.
- Additional landscape retaining walls, where indicated or where needed, shall follow the design criteria, material and finish as set forth in Exhibit C – Attachment 10-1 – 183 North Mobility Project Aesthetic Design Guide.
- The design approval process for proprietary walls shall be in accordance with the current TxDOT Policy for Proprietary Wall Systems. The DB Contractor shall use long vertical curves at the top of the wall's profile and avoid abrupt tangents, chords and vertical steps. The DB Contractor shall extend retaining walls into existing or finished grade where possible to avoid the use of guardrails at the ends.
- All proprietary walls shall meet the required factors of safety listed in the current TxDOT *Geotechnical Manual* and applicable wall standard. Aesthetic treatment applied to structures shall not affect the structure's ability to meet the design standards set out in Technical Provision 12.
- DB Contractor shall, upon completion of retaining wall formliner, construct a mockup for review and approval of the Mobility Authority.

10.4.1 Abutment Walls

Abutment wall configuration and finish shall meet the requirements found in Exhibit C – Attachment 10-1 – 183 North Mobility Project Aesthetic Design Guide.

10.5 Traffic Barriers

Aesthetic requirements for traffic barriers shall meet requirements found in Exhibit C – Attachment 10-1 – 183 North Mobility Project Aesthetic Design Guide.

10.6 Sound Walls

Sound walls shall meet requirements set forth in the Exhibit D - Item 2 – Environmental (Noise) and Exhibit C – Attachment 10-1 – 183 North Mobility Project Aesthetic Design Guide. Sound wall finish requirements, including coatings and textures, are found in Exhibit C – Attachment 10-1 – 183 North Mobility Project Aesthetic Design Guide. Sound wall aesthetics, treatments, and locations shall be shown in the Preliminary (30%) Design Submittal and the Intermediate (65%) Design Submittal. DB Contractor shall, upon completion of sound wall formliner, construct a mockup for review and approval of the Mobility Authority.

10.7 Overhead Sign Structures, Toll Gantries, and ITS

Overhead sign, Toll Gantry, and ITS structures shall meet requirements for overhead sign structures found in Exhibit C – Attachment 10-1 – 183 North Mobility Project Aesthetic Design Guide.

10.8 Shared Use Path

Shared use path shall meet the requirements found in Exhibit C – Attachment 10-1 – 183 North Mobility Project Aesthetic Design Guide.

Shared use path, special pavement finish and overhead art work aesthetic requirements for Pond Springs Road are found in the Shared Use Path special pavement and Overhead Art sections of Exhibit C – Attachment 10-1 – 183 North Mobility Project Aesthetic Design Guide.

Shared use path special pavement finish and overhead art work aesthetics, treatments, and locations shall be referenced in both roadway and affected bridge plans.

10.9 Aesthetic Lighting Fixture Standards

Exterior appearance of illumination pole and fixture assemblies shall meet requirements as follows:

- Pedestrian lighting fixture and light pole specifications:

Fixture:

Housing	Lens	Finish	Color	Sample Ordering Code
Single-piece, Die-cast aluminum housing	Top of Form Acrylic lens Bottom of Form	TGIC thermoset powder coating	Natural Aluminum	Lithonia Lighting D-Series Area Size 1, LED Area Luminaire (or approved equal)

Pole:

Material	Mounting Height	Mounting Type	Color	Sample Ordering Code
4-inch square, .01196 in wall thickness, weldable-grade, hot-rolled, commercial-quality carbon steel tubing	16 feet	Drill	Natural Aluminum	SSS-16-4C-DM19-DNA (or approved equal)

10.10 Typical Cross-street Intersection Conditions

10.10.1 Cleaning and Repair of Flat Work

All existing non-vehicular pavements shall be cleaned and restored prior to final acceptance of the project.

The cleaning and repair of median, traffic control island, slope paving and pedestrian pavements shall be as follows:

- Sweeping and removal of surface debris, removal of weeds within joints and cracks and washing by appropriate means and methods to remove surface dirt, organic stains and bio film, oil, grease, concrete slurry, paint and rust stains etc. from the pavement surface while not compromising the integrity of the pavement surface or the surrounding jointing materials.
- Paver systems will be washed using industry recognized environmentally safe cleaning agents and washing techniques shall be employed which will not damage pavement surface or unduly dislodge joint sand.
- Concrete flat work and concrete slope pavement will be cleaned and washed using agents and techniques which will not damage the pavement surface and not dislodge expansion joint materials.
- The existing sidewalk system parallel to and within the entire project corridor shall be cleaned using techniques which will not damage the pavement surface or joint materials.

As final step in the cleaning operations, inspect and restore all elastomeric joint sealants at expansion joints between fixed elements such as bridge foundations, utility structures, back of curb etc. and cast-in place concrete paving as well as expansion joints and opened control joints within cast in place concrete paving areas.

Where cleaning process has dislodged joint sand, restore sand joints using polymeric sand backfill to reduce intrusion of weed seeds and weed growth.

10.10.2 Cleaning of Existing Retaining Walls

All exposed surfaces of existing retaining walls, copings, wall mounted sign supports base, vehicle barriers to remain parallel to the service drives shall be cleaned using non-abrasive and non-etching solutions. Agents and techniques will be used which are environmentally friendly and will not cause damage to the finished surface of these elements. The cleaning process will remove organic films, mold, mildew, stains etc. resulting in a clean and uniform surface.

10.10.3 Cleaning of Existing Bridges

All outside faces edges and exposed surfaces of existing bridge caps, fascia girders, decks and vehicle barriers, rail mounted concrete sign supports bases, to remain and parallel to the service drives shall be cleaned and painted per the guidance found in *Exhibit C – Attachment 10-1 – 183 North Mobility Project Aesthetic Design Guide*.

Agents and techniques will be used which are environmentally friendly and will not cause damage to the finished surface of these elements. The cleaning process will remove organic films, mold, mildew, stains

etc. and provide a surface ready for the application of opaque sealer as indicated in Exhibit C – Attachment 10-1 – 183 North Mobility Project Aesthetic Design Guide.

10.10.4 General Non-Vehicular Paving

Paving and Flatwork features shall meet requirements found in Exhibit C – Attachment 10-1 – 183 North Mobility Project Aesthetic Design Guide.

Areas less than 10 feet in width shall be treated in accordance with Exhibit C – Attachment 10-1 – 183 North Mobility Project Aesthetic Design Guide and as approved by the Mobility Authority.

10.10.5 ADA Accessible Route

Within the areas of the Designated ADA accessible route through the cross-street interchanges, along the SUP undercrossing at Pond Springs Rd. and along the parallel walk system parallel to the service drives in the project limits, adjust surface elevations of all existing utility boxes, manholes, utility valves and hand holes within walking surface to meet ADA requirements.

HC ramps shall be installed at locations along accessible route in locations where needed to the current TXDOT standards unless otherwise indicated in Exhibit C – Attachment 10-1 – 183 North Mobility Project Aesthetic Design Guide.

10.11 Coatings and Textures

Coatings and textures for aesthetic treatments shall meet requirements found in Exhibit C – Attachment 10-1 – 183 North Mobility Project Aesthetic Design Guide.

10.12 Drainage and Grading Aesthetics

The DB Contractor's grading plans shall comply with the following guidelines:

- Slopes shall be in accordance with Technical Provision 11.
- Open Channels and Ditches shall be in accordance with Technical Provision 15.
- The DB Contractor shall adjust grading to minimize disturbance to existing native vegetation.
- The DB Contractor shall perform finish grading and place topsoil/compost mix on all areas to a 4-inch compacted depth within the limits of grading (and areas outside the limits of grading that are disturbed in the course of the Work) that are not paved or part of a rock outcropping feature.
- Reestablish the site's predevelopment drainage pattern, infiltration rates, sediment loads, and outflow volumes after construction, where practical. Design to minimize disturbance and impacts by preserving and/or mitigating sensitive areas that affect hydrology, including streams and their buffers, wetlands and steep slopes.

10.13 Landscape

The DB Contractor shall develop a corridor landscape plan which meets the requirements found in Exhibit C – Attachment 10-1 – 183 North Mobility Project Aesthetic Design Guide and the following additional requirements: The landscape plan shall be provided in the Preliminary (30%) Design Submittal and the Intermediate (65%) Design Submittal and the Final (100%) Design Submittal.

- The DB Contractor shall retain a Registered Landscape Architect. The landscape architect shall be experienced in designing similar roadway landscape design projects within the counties included in the Texas Department of Transportation – Austin District.
- Existing trees, vegetation and landforms should be preserved to the greatest extent possible. Areas that are outside of the construction limits required for this Project but are in the ROW shall be left undisturbed. Refer to Technical Provision 10. for maintenance of these areas.
- All existing landscape plantings between the service drives and the main lanes within the project limits shall be removed unless otherwise indicated in the Exhibit C – Attachment 10-1 – 183 North Mobility Project Aesthetic Design Guide. The DB Contractor shall prepare an Existing Plant Inventory Report indicating the location, type and size of all plantings to be removed as a part of construction operations. The inventory will include genus, species, height, spread, and diameter of trees (measured at the 54-inch height) as appropriate. Shrubs shall be inventoried with the height and spread recorded for each. The locations of all plantings to be removed will be documented both in plan (CAD) and via digital photography and summarized in the single report. The Existing Plant Inventory Report shall be provided along with the Preliminary (30%) Design Submittal.
- The results of the Existing Plant Inventory Report will be used to ensure that an equitable number of plantings are restored to the corridor as were removed. The Existing Plant Inventory Report plant quantities will be identified in a table within the Corridor Landscape Plan which identifies that new plantings quantities are equal to those removed during construction.
- The replacement of plant materials removed by necessary construction shall be focused at the following locations in descending order of importance until all replacement plantings have been accommodated:
 - Between the parallel service drive and the abutment retaining walls at cross street interchanges.
 - Select storm water quality and management ponds as indicated in the Exhibit C – Attachment 10-1 – 183 North Mobility Project Aesthetic Design Guide. Screen plantings will be composed of predominately shrub species which will provide adequate visual screening of the water quality facilities from adjacent service drive and cross-street motorists view. Screen plantings will be located behind

vehicle barriers and or outside of safety zone areas and will not violate required site distance clear zones.

- Between service drive and the general-purpose lanes as space allows.
 - Placement of street trees between the service drive and the outside face of bridges in the Pond Springs/McNeil and Spicewood Springs interchange.
 - Between the service drive and general purpose lanes proximate to Loop 360 crossing.
 - Within the areas north of the Loop 1 Interchange infield areas as space allows.
- The landscape design must consider travel speeds, sight distance, drainage needs and other elements that impact the safety and views of the motorists within, entering and or leaving the Project.
 - Plant materials must be of a genus, species and variety which have demonstrated success in the Austin area and after establishment be self-sustaining and not require supplemental watering and are found on the acceptable species list in Exhibit C – Attachment 10-1 – 183 North Mobility Project Aesthetic Design Guide. The preferred design is to be composed of native plant species however, naturalized species which have a demonstrated success and are not invasive may also be incorporated into the design as acceptable to the Mobility Authority.
 - The design to the extent practical, shall use trees to either screen undesirable views, such as power lines or residential views towards the roadway, to enhance positive views, and to provide shade in pedestrian areas.
 - The use of shrubs shall be reserved for the plantings at cross street interchanges and screening of storm water quality facilities.
 - Shrubs shall be contained within planter walls and or landscape curbs which are suitable for separating the plantings from the adjacent surfaces, provide containment of organic mulch and prevent drainage from passing through and eroding or dislodging mulch.
 - The DB Contractor shall not plant trees within the prescribed clear zone, as defined in Technical Provision 11.
 - The DB Contractor shall develop a landscape and vegetative watering plan that accommodates the proposed plantings. Watering of landscape shall be defined as furnishing and applying water free of harmful materials and suitable for vegetation via truck. The vegetative watering shall be continued during the establishment and maintenance periods until final acceptance.

10.14 Preservation and Repair of Areas to be Preserved

10.14.1 Tree and Plant Preservation

Scope. Provide complete protection and maintenance of existing trees to be preserved identified in Exhibit C – Attachment 10-1 – 183 North Mobility Project Aesthetic Design Guide. The DB Contractor shall erect protection fencing around all plantings to be protected at locations as indicated on the Final Schematic Plan and the requirements of this Technical Provision 10.

- Access gates to permit access for the routine mowing and litter control shall be provided for each area of protection fencing where required to adequately maintain area confined by protection fence.
- The contractor shall continue to provide regular maintenance of the tree protected areas per the project requirements.
- The protection fencing will be removed and the turf restored along fence lines and interior areas as needed to restore a uniform turf cover at the end of the construction of improvements within that location.

10.14.2 Maintaining Existing Vegetation and Soils

Maintain existing vegetation and soils to the greatest extent practicable. Retaining undisturbed vegetation and soils is an effective means of erosion and sedimentation control.

Removal of existing native and non-native vegetation, shall be limited to the areas as indicated in Exhibit C – Attachment 10-1 – 183 North Mobility Project Aesthetic Design Guide particularly mature/semi mature trees and shrubs should be avoided to the greatest extent practicable. Wherever practicable, impacted vegetation shall be replaced with in-kind on-site replacement/restoration of native vegetation of like or similar specie or as otherwise approved by the Mobility Authority.

Design Requirements

The DB Contractor to prepare vegetation preservation plan confirming the areas of existing vegetation to be avoided and protected throughout the construction period. Plan shall designate the location of protective fencing outside the critical root zones (CRZ) of trees and other mass planted vegetation to be protected. (Note: CRZ radius = 1 foot per inch of the trunk’s diameter measured at 54-inch height).

- If construction requires encroachment within the CRZ, locate protective fencing outside the drip line (edge of canopy) of the preserved trees to the extent possible.
- Designate trunk armoring for locations where construction activities may potentially encroach on a portion of the CRZ. If trunk armoring is used, the CRZ protection is still required to the extent possible.

- Incorporate appropriate sedimentation control measures outside the tree protection fencing on upslope areas to prevent sediment from collecting within the root zone.

Construction. Install protective fencing and signs prior to demolition or excavation operations. Leave protective fencing in place until construction operations are complete. Remove protective measures at Final Acceptance.

- Equipment, construction materials, topsoil, and fill dirt shall not be placed within protective fencing.
- Protect existing trees, shrubs, grass and soils areas to be maintained from the following damage:
 - Compaction of tree CRZ root area by equipment, vehicles or material storage.
 - Trunk damage by moving equipment material storage or movement, nailing or bolting.
 - Strangling by tying ropes or guy wires to trunks or large branches.
 - Poisoning by pouring solvents, gas, paint or other chemicals on or around trees and roots, within the CRZ and on or around shrubs or grass areas within Designated Preservation Areas.
 - Improper cutting of roots by excavating or ditching.
 - Damage of branches.
 - Drought from failure to water or by changing normal drainage pattern near roots.
 - Disposal of construction materials, including lime base materials such as concrete or plaster.

Construction Requirements for Access, Utility, or Other Easements. Minimize construction impacts from required access, utility or other easements located in CRZ areas with existing vegetation to be protected DB Required tree root and branch pruning shall meet International Society of Arboriculture (ISA) standards. Staging areas shall be located outside these areas. Required easements in these areas shall be seeded per the requirements of Technical Provision 10.

Materials:

- Protective fencing may be orange construction fencing (plastic) or cord fencing (wire) in accordance with TXDOT Item 506 “Temporary Erosion, Sedimentation, and Environmental Controls.” Protective fencing may also be constructed of 4x4 posts and 2x4 stringers top and bottom.
- Trunk armoring should consist of 2x4 wood boards strapped vertically to the tree no more than 2 inches apart and to a height of 5 feet encircling the trunk.

- Protective signage should be composed of Corex or Coroplast and weather proofed with a dimension of 18x24 inches. The sign shall be yellow with black graphics that state: “Vegetation Protection Area. Do not Disturb”; include the Mobility Authority logo on the sign. Sign shall be securely anchored to the protective fencing or mounted to a post. A minimum of one sign per preserved tree shall be installed and at a rate of one sign per 500 feet of Designated Preservation Areas.

Maintenance Requirements. Replace protective fencing and signs immediately if missing. Remove and dispose of protective measures and signs at Final Acceptance.

References:

Texas Commission on Environmental Quality (TCEQ), Complying with the Edwards Aquifer Rules, Technical Guidance on Best Management Practices, 2005 Section 2.5.1, Tree Protection.

10.15 Seeding Revegetation

Revegetation of all areas disturbed by construction and not otherwise paved or planted as a part of the landscape plan shall be stabilized per the standard seeding specifications. Erosion control planting shall be in accordance with TxDOT standards and Technical Provision 9 and Technical Provision 15.

10.16 Maintenance and Establishment Period

The DB Contractor shall be responsible for the care of all revegetated areas, installed plants, and designated protected areas on the Project, in accordance with the requirements of the current TxDOT *Standard Specifications for Construction and Maintenance of Highways, Streets, and Bridges*, adopted by TxDOT in November 2014, for a period as set forth in Technical Provision 3.

During the maintenance and establishment period, the DB Contractor shall replace the plant materials when they are no longer in a healthy condition as determined by the Mobility Authority. The DB Contractor shall make replacement plantings in the planting season, except as otherwise approved in writing by the Mobility Authority. The DB Contractor shall remove dead plants within 10 Business Days of discovery, and DB Contractor shall replace such plants during the next planting season. Replacements shall be of the same species and variety of the originally specified material, unless otherwise approved in writing by the Mobility Authority, and shall be installed as specified herein. If a replaced plant requires another replacement during the maintenance and establishment period, the new replacement shall also be covered for the maintenance and establishment period.

After Final Acceptance, the Mobility Authority will review the completed landscape installation with the DB Contractor's representative on a quarterly basis during the Planting and Establishment period. Plant material health, mulching, erosion control and other maintenance concerns will be specifically noted and addressed by the DB Contractor. Replacement needs will be noted and directed to the DB Contractor during the Planting and Establishment period for replacement.

10.16.1 Mowing

The Mowing procedures provides guidance on effective mowing practices within the ROW, maintain vegetation heights for safety, and control noxious and undesirable plants. Mowing at prescribed rates allows grass to establish, thrive, and maintain a vigorous stand of vegetation on the roadsides, which prevents weed invasion and reduces soil erosion and sedimentation.

Concrete paving or landscape pavers shall be used in hard-to-reach mowing areas or under structures such as, but not limited to, areas between, near, or next to guard fence posts, bent columns, retaining walls, freeway ramp gores, paved ditches, flumes, and ditch inlets. For areas as noted above adjacent to or within existing paver areas, restore or provide matching pavers and pattern. For new locations away from paver surfaces install natural gray broom finished concrete. A standard 2'-0" wide mow strip shall be provided along face of bent columns, retaining walls, freeway ramp gores, paved ditches, flumes and ditch inlets. For mow strip along guard fence posts, follow TxDOT standards. For all other remnant areas less than 8 feet in width (and not otherwise planted), shall be fully paved. Median areas with widths of 10 feet or less completely surrounded by vehicular traffic or structures shall be entirely paved.

Instructions:

Mow Zone

Width and Location: All areas of the existing corridor which are not otherwise needed for construction and or construction activities and containing turf grasses shall be mowed.

Mowing rate: Mow 3 times per year in the following months: February, June and November, or as directed.

Mowing height: 6 inches.

Woody vegetation: Keep exiting turf areas free of volunteer woody vegetation. Remove all volunteer trees or woody vegetation during each mowing operation.

Mowing for Invasive Species Control

Reference "Invasive Species Control" in this *Technical Provision 10*.

Other Mowing Guidelines:

Mow to provide sight distance at horizontal curves, intersections, driveways and ramps to ensure roadway visibility.

Do not mow when soils are saturated or in a muddy condition as this may damage soil retention blankets and established vegetation, destabilize slopes, and promote erosion and sedimentation.

Slopes greater than 3:1 should not be mowed.

Areas not established with vegetation, or undergoing revegetation, should not be mowed to reduce erosion and sedimentation potential.

Quality Control Submittals. Submit product data and sample for sign in accordance with Tex-726-I.

10.16.2 Invasive Species Control

Invasive species control is the removal, management, and/or prevention of invasive plant species that displace or harm the viability of vegetation intended for establishment, as specified or within the landscape plans below. Revegetated landscape areas shall not consist of more than 10% invasive areas per acre. Corrective measures shall be implemented when invasive species exceed 10% per acre of revegetated area. To greatest extent possible formal landscape planters shall be maintained to eliminate invasive species during the maintenance period.

The Invasive Species Control specifications provide an effective approach to control invasive plant species.

References:

- Federal Insecticide, Fungicide, and Rodenticide Act
- Texas Pesticide and Right-to-Know Laws and Regulations (TDA)
- Texas Structural Pest Control Board Act
- Federal Seed Act
- Texas Seed Law

Instructions:

Identify invasive plant species along (see “Inspection” below).

Invasive species can best be managed through the use of chemical or mechanical control. Determine which technique is most appropriate to control invasive species for a specific site considering the following conditions:

- Severity of the invasive species.
- Topography of the area infested.

Corrective Measures:

Chemical control techniques refer to the use of herbicides; some invasive plant species cannot be controlled without the use of state-regulated herbicides. There are many kinds of herbicides, and not all of them will be appropriate for every situation. The choice of chemical control depends on the target population, stage of growth, the presence of nearby existing species that may be affected by spray drift and the proximity of

water resources. Herbicides must always be applied in accordance with the label. Always ensure regulated herbicides are applied by licensed applicator in accordance with state and local laws.

Mechanical control techniques include mowing, tilling and chopping. These techniques are most useful in areas with large infestations where terrain does not create safety or equipment issues.

Repeated mowing or cutting of invasive plants weakens the invasive plant population by depleting root reserves and preventing flowering and seeding. If infestations are small, the cost of mechanical control is usually relatively low, and when combined with other treatments it can be very effective.

Listed below are common woody, herbaceous, and aquatic invasive species in Travis County. Invasive species control techniques should be used if any of the below species are found on site. The herbaceous species list is categorized by control categories to indicate the measures needed to control certain species. Category 1 species may be targeted and eliminated easily, while Category 2 species may be difficult to eliminate. In Category 2 cases the species population should be controlled within means, rather than complete eradication.

**Table 10-1: Invasive Woody Plant Species for Travis County
(A selective list of current or potential occurrence.)**

Scientific Name	Common Name
<i>Ailanthus altissima</i>	Tree-of-Heaven
<i>Broussonetia papyrifera</i>	Paper mulberry
<i>Firmiana simplex</i>	Chinese parasoltree
<i>Fraxinus texensis</i>	Texas Ash
<i>Ligustrum</i> spp. (<i>L. japonicum</i> , <i>L. lucidum</i> , <i>L. quihoui</i> , <i>L. sinense</i> , <i>L. vulgare</i> , etc.)	Ligustrum; privet
<i>Lonicera japonica</i>	Japanese Honeysuckle
<i>Macfadyena unguis – cati</i>	Catclaw Vine
<i>Melia azedarach</i>	Chinaberry
<i>Nandina</i> spp.	Nandina
<i>Photinia</i> spp. (<i>P. serratifolia</i> ; <i>P. x fraseri</i> , etc.)	Chinese Photinia; red-tip photinia etc.
<i>Pistacia chinensis</i>	Chinese pistache
<i>Pueraria lobate</i>	Kudzu
<i>Pyracantha coccinea</i>	Pyracantha; Firethorn
<i>Triadica sebifera</i> (<i>Sapium sebiferum</i>)	Chinese Tallow Tree
<i>Vitex agnus-castus</i>	Chaste bush; Chastity tree
<i>Hedera helix</i>	English ivy
<i>Morus alba</i>	White Mulberry
<i>Tamarix</i> spp.	Saltcedar

**Table 10-2: Invasive Herbaceous Plant Species for Travis County
(A selective list of current or potential occurrence.)**

Scientific Name	Common Name	Control Category*
<i>Arundo donax</i>	Giant reed, Giant cane	1
<i>Centaurea melitensis</i> ; <i>Centaurea solstitialis</i>	Maltese star-thistle; Yellow star-thistle	1
<i>Convolvulus arvensis</i>	Field Bindweed	1
<i>Cyrtomium falcatum</i>	Asian hollyfern	1
<i>Phyllostachys aurea</i>	Golden bamboo	1
<i>Rapistrum rugosum</i>	Annual Bastardcabbage	1
<i>Ruellia brittoniana</i>	Mexican petunia; Britton ruellia	1
<i>Sorghum halepense</i>	Johnsongrass	1
<i>Verbena brasiliensis</i>	Brazilian vervain	1
<i>Bothriochola ischaemum</i> var. <i>songarica</i>	King Ranch Bluestem	2
<i>Bromus arvensis</i> ; <i>Bromus catharticus</i>	Field brome; Rescuegrass	2
<i>Dichanthium sericeum</i> (also <i>D. annulatum</i> ; <i>D. aristatum</i>)	Silky Bluestem (also other Old world bluestems such as Kleberg and Angleton bluestems)	2
<i>Festuca arundinacea</i> (<i>Schedonorus phoenix</i>)	Tall Fescue	2
<i>Lolium perenne</i>	Italian ryegrass	2
<i>Medicago minima</i> (also <i>Medicago arabica</i> ; <i>Medicago lupulina</i> etc.)	Least burclover (and other burclovers)	2
<i>Melilotus indicus</i> (and <i>M. albus</i> etc.)	Yellow sweetclover (and other spp.)	2
<i>Paspalum dilatatum</i>	Dallisgrass	2
<i>Paspalum urvillei</i>	Vaseygrass	2

*Category 1 species are relatively easy to target individual plants or clusters.

*Category 2 species, although sometimes very problematic, are often widely and abundantly dispersed throughout the vegetative matrix, making them more difficult to target or to eliminate. Although elimination would be desirable, controlling populations to a less disruptive level is acceptable.

**Table 10-3: Invasive Aquatic and Wetland Plant Species for Travis County
(A selective list of current or potential occurrence)**

Scientific Name	Common Name
<i>Alternanthera philoxeroides</i>	Alligatorweed
<i>Colocasia esculenta</i> (and <i>Xanthosoma sagittifolium</i>)	Elephant ear
<i>Eichhornia crassipes</i>	Water hyacinth
<i>Hydrilla verticillata</i>	Hydrilla
<i>Myriophyllum spicatum</i>	Eurasian watermilfoil
<i>Pistia stratiotes</i>	Water lettuce
<i>Salvinia molesta</i> and <i>Salvinia minima</i>	Giant salvinia and Common salvinia

10.17 Submittals

Table 10-4: Submittals to Mobility Authority

Submittals	Submittal Schedule	Mobility Authority Action	Reference Section
Preliminary Aesthetics Design Plan	Prior to or in conjunction with: (1) Preliminary (30%) Design Submittal and (2) Intermediate (65%) Design Submittal	Review and comment	10.1
Concrete Wall Sample	Prior to Constructing any Retaining wall	Approval	10.4

11.0 ROADWAY DESIGN

11.1 General Requirements

The requirements contained in this Technical Provision 11 provide the framework for the design and construction of the roadway improvements to help attain the Project objectives.

The DB Contractor is responsible for the design and construction of the roadway elements in accordance with the requirements identified in this Technical Provision 11 and Exhibit C – Attachment 11-1 – Design Criteria Summary – Project Roadways. The DB Contractor shall coordinate roadway design, construction, and maintenance with other elements of the Project to achieve the Project objectives. Other Project elements that are dependent on the geometry or the design of roadway elements, including drainage, retaining walls, utilities and bridge structures, shall be completed in accordance with their respective Technical Provisions and this Technical Provision 11 and Exhibit C – Attachment 11-1 – Design Criteria Summary – Project Roadways.

All roadway Work shall be in accordance with the Exhibit B – Scope of Work and the Basic Configuration as defined in Exhibit A – Abbreviations and Definitions. The DB Contractor shall refer to the Environmental Documents provided in Exhibit D – Item 2 – Environmental and the Schematic Plan provided in Exhibit D – Item 3 – Technical (Roadway) for the design configuration and construction limits of the Project.

In addition to all other requirements applicable to the Work hereunder, the DB Contractor shall prepare the final geometric design of the roadway elements of the Project Design. These shall be in accordance with sound engineering judgment and current standards for safety, operations and maintenance. The Environmental Documents contain certain assumptions and criteria for which certain Environmental Approvals and other Governmental Approvals are or will be based. Deviations from these criteria may require revisions to, or reissuance of, the Environmental Approvals and/or Governmental Approvals. The DB Contractor shall not be entitled to any time extension or additional compensation in connection with such revisions or reissuance with the exception of changes requested by the Mobility Authority.

In locations where design development result in revisions to the Project ROW, the DB Contractor is responsible for demonstrating the proposed alignment is an equally safe alternative, as well as the initiation and progression of all environmental and public involvement processes in coordination with the Mobility Authority. The DB Contractor shall perform all ROW acquisition services that are necessitated by proposed changes in accordance with the Contract Documents.

The Mobility Authority encourages all positive and creative design solutions that facilitate the development plans of adjacent property owners and support the success of the Project. The DB Contractor should also be open to design requests from adjacent property owners that are financially feasible, environmentally sound, and help expedite the overall design, Utility, ROW, and construction processes.

11.2 Roadway Design Criteria

The roadway design criteria for the Project are specified in Exhibit C – Attachment 11-1 – Design Criteria Summary – Project Roadways. Roadway elements not listed in this attachment shall be designed in accordance with the criteria included in the references stated in Technical Provision 11.4.

A list of Design Exceptions have been approved for the Project and are included in Exhibit D – Item 3 – Technical (Design Reports). The DB Contractor shall be responsible for reviewing all elements of the Project and obtaining approval for any additional Design Exceptions or design waivers needed.

Any changes that may affect Environmental Approvals, permitting, or commitments indicated in the Reference Documents or any related impacts shall be at the cost and sole responsibility of the DB Contractor, shall not negatively impact the Project schedule and shall comply with Technical Provision 22.

Any proposed revisions resulting in changes to access and capacity must be approved by the Mobility Authority, in accordance with follow the Alternative Technical Concept (ATC) process, as described in the Instructions to Proposers.

11.3 General Scope Requirements

In addition to the scope requirement stated in Exhibit B – Scope of Work and the Basic Configuration as defined in Exhibit A – Abbreviations and Definitions, the DB Contractor shall be responsible for completing the Project in accordance with this Technical Provision 11 and Schematic Plan as found in Exhibit D – Item 3 – Technical (Roadway). In the absence of specific criteria herein, the Project Design shall conform to applicable standards and criteria of TxDOT, AASHTO and FHWA.

11.4 Standards and Guidelines

Primary Design Criteria. The roadway design of the Project shall be in accordance with the TxDOT *Roadway Design Manual* Revised April 2018. The guidance in the geometric design of roadway facilities in this manual shall be used for each of the design elements described in Technical Provision 11.5, unless otherwise noted.

Other Design Criteria. Unless otherwise specified in the Contract Documents, the roadway design shall be governed by current TxDOT policies, specifications, standards, manuals, guidelines, and technical memoranda, including all addenda, supplements, and revisions thereto. Generally, the design shall comply with the criteria established by the Mobility Authority, TxDOT, and AASHTO. The current version (current version as of the date of the Proposal) of these references shall be used unless otherwise specified.

When no particular standard or criterion is specified in the Contract Documents, then the following hierarchy of standards will apply:

- Mobility Authority

- TxDOT
- TMUTCD
- AASHTO
- Applicable local public agency standards

The use of Austin District Standards provided in *Exhibit D – Item 3 – Technical (Roadway)* is preferred. The use of TxDOT District Standards from other districts requires the Mobility Authority approval and will need to be signed and sealed by a Registered Professional Engineer.

List of standards and guidelines applicable to this Technical Provision:

- AASHTO A Policy on Geometric Design of Highways and Streets, 2018 7th Edition
- AASHTO Roadside Design Guide
- TxDOT Standard Specifications for Construction and Maintenance of Highways, Streets, and Bridges
- TxDOT Access Management Manual
- TxDOT Hydraulic Design Manual
- TxDOT Roadway Design Manual
- Americans with Disabilities Act of 1990 (ADA), as amended (42 USC §§12101, et seq.) and the Texas Accessibility Standards (TAS)
- U.S. Access Board Guidelines and Standards for Streets and Sidewalks in the Public Right-of-Way including Shared Use Paths
- AASHTO Guide for the Development of Bicycle Facilities

In all cases desirable values will be used. Minimum values may only be used with approval by the Mobility Authority. The DB Contractor must provide justification for the usage of any minimum standard. Justification based solely on cost or schedule will not result in approval.

11.5 Roadway Elements

Roadway elements shall be designed in accordance with *Exhibit C – Attachment 11-1 – Design Criteria Summary – Project Roadways*. Reference to Design Speed in this attachment and this *Technical Provision 11* shall mean the selected speed used to determine the various roadway design features. In addition, the following sections provided additional roadway element requirements.

11.5.1 Traffic Lanes

The DB Contractor shall implement the number and length of all vehicular lanes in accordance with Exhibit B – Scope of Work, the Basic Configuration as defined in Exhibit A – Abbreviations and Definitions and Schematic Plan as found in Exhibit D – Item 3 – Technical (Roadway). Traffic lanes include but are not limited to express lanes, general purpose lanes, ingress/egress ramps between express lanes and general purpose lanes, auxiliary lanes, speed change lanes, direct connector lanes, entrance/exit ramp lanes, collector-distributor lanes, frontage road lanes, turn-around lanes, and all turn-lanes.

The DB Contractor shall comply with the TxDOT *Roadway Design Manual* regarding the design standards, guidance, and requirements for left and right-turn lanes design. The DB Contractor shall be responsible for reviewing all turning movements at the intersection of crossing roads along the Project corridor and for the development of intersection geometric alignments that will accommodate the appropriate design vehicle.

Express lanes shall be constructed along the median of US 183 between the northbound and southbound general purpose lanes. The express lanes shall be separated from the general purpose lanes by a 4-foot buffer unless otherwise shown on the Schematic Plan provided in Exhibit D – Item 3 – Technical (Roadway) and include markings and surface mount flexible white color delineators in accordance with Technical Provision 16 requirements. Delineators shall be located centrally within the 4-foot buffer and installed every 6 feet. Delineators shall be 36-inches in height. Within 800 feet of ingress/egress access locations and along the associated speed change lanes, delineators shall be 28-inches in height.

New pavement along the express lanes, the additional general purpose lanes, roadway reconstruction, and roadway widening shall, to the extent possible, be constructed to match the existing pavement grade along the line connecting the new pavement to the existing pavement. The DB Contractor, shall be under no obligation to adjust the cross slope of the existing pavement to remain as long as all other design requirements can be satisfactorily met.

11.5.2 Driveways and Entrances

The DB Contractor shall comply with the TxDOT *Roadway Design Manual* and TxDOT *Access Management Manual* and the latest TxDOT Standards for pedestrian facilities regarding design standards, guidance, and requirements for driveways. Existing driveways that abut newly constructed pedestrian facilities shall be in compliance with the Americans with Disabilities Act Accessibility Guidelines and Texas Accessibility Standards to the extent feasible within the scope of the Project. The DB Contractor shall be responsible for obtaining a design variance from TDLR for locations where these design guidelines are not met. The DB Contractor shall restore all connections to any driveways that connect to the existing frontage roads or the existing crossing roads prior to the Substantial Completion of the Project.

General driveway information has been provided showing preliminary impact limits due to restoration of driveway after construction of sidewalks. The DB Contractor shall be responsible for the driveway connections and pavement removal and construction, however the DB Contractor shall not be responsible

to correct existing driveway deficiencies. Refer to Exhibit D – Item 3 – Technical (Roadway) for project specific driveway detail.

The DB Contractor shall re-establish all irrigation, illumination, drainage elements, and other improvements impacted directly or indirectly by the construction of sidewalks and driveways.

11.5.3 Traffic Barriers and Attenuators

The DB Contractor shall provide traffic barriers which protect traffic from roadside hazards such as overhead signs, culvert headwalls, non-traversable side slopes, bridge piers and other obstructions within the horizontal clear zone. All permanent and temporary traffic barriers, rigid or flexible, shall meet current applicable guidelines for traffic barriers. Where necessary the DB Contractor shall replace sections of existing flexible barriers and terminals within the Right of Way to comply with current standards. All blunt ends shall be protected with an appropriate safety end treatment including impact attenuators. The DB Contractor shall comply with the TxDOT *Roadway Design Manual* and *AASHTO Roadside Design Guide* regarding the design standards, guidance, and requirements for traffic barriers design and horizontal clear zone design.

Permanent rails and barriers shall be free of damage and discoloration and shall maintain consistent color and appearance along their length. Steel traffic rails or concrete traffic rails with steel posts shall not be used. Metal components shall only be used for modified rails required to accommodate pedestrians. No temporary traffic control barrier shall be used as permanent barrier. Prior to placement, mock-up samples of slip-form and cast-in-place rails and barriers shall be provided as described below:

- Slip form: 20 LF sample length of the same size, shape, and finish as the proposed element.
- Precast: Same size, shape and finish as the proposed precast unit(s). The mock-up sample(s) will be prepared at the fabrication plant(s).

If any areas require maintenance (such as grass or paved median area between barriers) the DB Contractor shall provide gates in the barrier of sufficient size and location for maintenance vehicles to utilize. Access gate type and location shall be approved by the Mobility Authority.

Existing and proposed structures that are within the clear zone shall be protected. If existing protection does not meet current standards, the barrier, rigid or flexible, shall be replaced or upgraded to meet standards.

The DB Contractor shall provide a continuous concrete median barrier separating the opposing traffic of the express lanes on the Project.

Continuous general purpose roadway sections greater than 300 feet in length that are requiring traffic barriers shall be protected using concrete barrier or bridge rail, not metal beam guard fence (MBGF).

MBGF reflector attachments shall be GF2 per TxDOT Traffic Delineator and Pavement Markings Standards. All MBGF shall receive a mow strip per TxDOT standards.

Where barriers are required along bridges and retaining walls, only concrete barriers are allowed. Barrier needed upstream and downstream of all bridges and retaining walls shall be an extension of the bridge rail. Single Guardrail Terminals (SGTs) and three-beams will be used at the upstream ends of these barriers, as required.

The area between the edge of the paved shoulder and the edge of the concrete barrier shall be paved to match the paved shoulder pavement.

The DB Contractor shall be responsible for determining proper locations for attenuators within the corridor. If attenuators are used, the DB Contractor shall comply with the TxDOT *Roadway Design Manual* and AASHTO *Roadside Design Guide* which contains design guidance and general information for impact attenuators. SGTs shall be used at ends of guardrails throughout the Project. TRACC systems or equivalent shall be used where crash attenuators are required.

11.5.4 Medians

The DB Contractor shall comply with the TxDOT *Roadway Design Manual* and TxDOT *Access Management Manual* regarding the use and requirements for median designs when warranted. Locations of all median openings shall be determined by the DB Contractor and reviewed for acceptance by the Mobility Authority.

11.5.5 Front Slopes and Back Slopes

Front Slopes and Back Slopes are the slopes of the final grade lines between the pavement of different roadways or between roadway pavement and the ROW/easement lines. Front Slopes are adjacent to the roadway and Back Slopes are not adjacent to the roadway. Slopes steeper than 4:1 may be permitted in some instances in order to limit the amount of ROW impacts. If slopes steeper than 4:1 are required, the DB Contractor shall obtain approval from the Mobility Authority, during the design process, and detailed site-specific stability analyses will be required. Justification based solely on cost or schedule will not result in approval. The DB Contractor shall refer to the TxDOT *Roadway Design Manual* regarding design limitations and roadside safety guidelines associated with the design of slopes along roadways.

Technical Provision 15 provides drainage requirements for median and roadside ditches including ditch depths and lining.

11.5.6 Pedestrian Traffic and Crossings

Within the limits indicated on the Schematic Plan, the DB Contractor shall determine the final horizontal locations of all sidewalks and the Shared Use Path along general purpose lanes and cross streets as required for safe passage of pedestrian traffic within the Project corridor as shown on the Schematic Plan in *Exhibit*

D – Item 3 – Technical (Roadway). Sidewalks and Shared Use Paths shall be concrete paved consistent with the TxDOT Austin District Standard and shall not receive construction joints. Pedestrian handrail shall be Type B or Type F per TxDOT Pedestrian Handrail Details Standard.

Crosswalks and curb ramps shall be provided at all intersections with new pedestrian facilities that are to be controlled by stop signs or traffic signals. Crosswalks that enter medians shall be flush and offer curb protection to provide safe refuge for crossing pedestrians and meet all state and federal accessibility requirements.

The DB Contractor shall comply with the TxDOT *Roadway Design Manual*, Americans with Disabilities Act of 1990, Texas Accessibility Standards (TAS), TMUTCD, TxDOT Standards and *Technical Provision 10* regarding design standards, guidance, and information for sidewalks, curb ramps, pedestrian traffic, and crossings locations. The *Proposed Accessibility Guidelines for Pedestrian Facilities in the Public Right-of-Way* shall be used as guidance to ensure compliance with the Americans with Disabilities Act. The DB Contractor shall be responsible for obtaining a design variance from the governing agency whenever these guidelines or TAS are not met.

11.5.7 Bicycle Facilities

The DB Contractor shall comply with the *AASHTO Guide for the Development of Bicycle Facilities* and the *Texas Manual on Uniform Traffic Control Devices* regarding design standards, guidance, and information concerning bicycle facilities. Bicycle facilities intended for shared use with pedestrians (shared use paths) must also comply with the Americans with Disabilities Act (ADA) of 1990, Texas Accessibility Standards (TAS), and other requirements for pedestrian facilities.

Separation distance between the roadway and shared use path may be permitted to be less than 5 feet in some instances in order to limit the amount of ROW impacts as shown on the Schematic Plan in *Exhibit D – Item 3 – Technical (Roadway)*. The DB Contractor is not required to install a physical barrier or railing between the shared use path and the frontage road.

The preferred location for the shared use path shall be near the ROW line, providing maximum separation from the general purpose lanes.

11.6 Aesthetics Design Elements

The DB Contractor shall incorporate landscape and aesthetics treatments into the Final Design in accordance with *Technical Provision 10*.

11.7 Additional Requirements

11.7.1 Standard Design Plans

Standard plans are to be a primary source of information regarding the preferred and acceptable means of performing any type of Work that is redundant. The DB Contractor shall use the TxDOT *Standard Plans*, as appropriate for the specific design of the roadway and structures. Any requested modifications to the TxDOT *Standard Plans* must be submitted as a part of the Formal Design Review prior to implementation.

11.7.2 Surveying and Construction Staking

See Technical Provision 23.

11.7.3 Submittals

With the Preliminary (30%) Design Submittal, the Intermediate (65%) Design Submittal, and the Final (100%) Design Submittal, the DB Contractor shall submit a plan for approval by the Mobility Authority that addresses the following:

- Asbestos on Bridge Structures.
- Lead Based Paint on Structures.
- Temporary easements or other temporary real property interests necessary to perform the Work

The plan will conform with all environmental requirements as per Technical Provision 9.

Table 11-1: Submittals to Mobility Authority

Submittals	Submittal Schedule	Mobility Authority Action	Reference Section
Roadway Plan	With: 1. Preliminary (30%) Design Submittal, 2. Intermediate (65%) Design Submittal, 3. Final (100%) Design Submittal	Acceptance	11.7.4

12.0 BRIDGES & HIGHWAY STRUCTURES DESIGN

12.1 General

The DB Contractor is responsible for completing the bridge, wall, sign, drainage and other highway structures in accordance with the requirements identified in this *Technical Provision 12* and *Technical Provision 10* and its referenced attachments.

The DB Contractor shall conduct subsurface investigations for all bridges, retaining walls, sound walls, culvert structures, and sign support structures in accordance with the requirements set forth in *Technical Provision 14*.

Throughout the Term, the DB Contractor shall allow access to TxDOT bridge inspectors performing National Bridge Inspection Standards (NBIS) inspections. The DB Contractor shall coordinate with TxDOT 90 days prior to opening any portion of the new bridge to traffic to allow for the initial NBIS inspection by TxDOT.

12.2 Standards and Guidelines

Structural design shall be in accordance with AASHTO Load and Resistance Factor Design (LRFD) Bridge Design Specifications 2017 8th edition with the current Interim Revisions as modified by TxDOT design practices. The reference in the Purpose Paragraph of Chapter 1 Section 1 of the TxDOT *Bridge Design Manual- LRFD to AASHTO Load and Resistance Factor Design (LRFD) Bridge Design Specifications 2012 6th edition* is hereby amended to refer to *AASHTO Load and Resistance Factor Design (LRFD) Bridge Design Specifications 2017 8th edition with the current Interim Revisions*.

- *AASHTO A Policy on Geometric Design of Highways and Streets*
- *AASHTO Construction Handbook for Bridge Temporary Works*
- *AASHTO Guide Design Specifications for Bridge Temporary Works*
- *AASHTO Manual for Bridge Evaluation*
- *AASHTO LRFD Guide Specifications for Design of Pedestrian Bridges*
- *AASHTO LRFD Bridge Design Specifications 2012 6th edition with the current interim revisions*
- *AASHTO LRFD Bridge Construction Specifications*
- *AASHTO Standard Specifications for Structural Supports for Highway Signs, Luminaires, and Traffic Signals*
- *AASHTO Standard Specifications for Highway Bridges*
- *ACI 318-14 Building Code Requirements for Structural Concrete*

- *ACI 318R-14 Commentary on Building Code Requirements for Structural Concrete*
- *AISC Steel Construction Manual, Thirteenth Edition*
- Americans with Disabilities Act of 1990 (ADA), as amended (42 USC §§12101, *et seq.*) and the Texas Accessibility Standards (TAS)
- *AASHTO/AWS D1.5 Bridge Welding Code*
- *AREMA Manual for Railway Engineering*
- *FHWA Hydraulic Engineering Circular 18 (HEC 18), Evaluating Scour at Bridges*
- *FHWA Hydraulic Engineering Circular 23 (HEC 23), Bridge Scour and Stream Instability Countermeasures*
- *FHWA Design and Construction of Mechanically Stabilized Earth Walls and Reinforced Soil Slopes (FHWA GEC 011)*
- *FHWA Regulation 23 CFR 772, Procedure for Abatement of Highway Traffic Noise and Construction Noise*
- *MASH AASHTO Manual for Assessing Safety Hardware*
- *Texas Manual on Uniform Traffic Control Devices (TMUTCD)*
- *TxDOT Standard Specifications for Construction and Maintenance of Highways, Streets, and Bridges*, adopted by TxDOT in November 2014.
- *Texas Steel Quality Council Preferred Practices for Steel Bridge Design, Fabrication, and Erection*
- *TxDOT Bridge Detailing Guide*
- *TxDOT Bridge Project Development Manual*
- *TxDOT Bridge Railing Manual*
- *TxDOT Geotechnical Manual*
- *TxDOT Guidelines for Analysis and Abatement of Highway Traffic Noise*
- *TxDOT Hydraulic Design Manual*
- *TxDOT Bridge Design Manual- LRFD*
- *TxDOT Roadway Design Manual*
- *TxDOT Concrete Repair Manual*
- *TxDOT Engineering Standard Sheets*

12.3 General Requirements

12.3.1 Drawing Format

Drawings and other submittals for all structures shall be in accordance with TxDOT practices, using TxDOT Standards, Specifications, details, sheets, and title blocks with English units of measure. Specific provisions for bridges shall follow the TxDOT *Bridge Detailing Guide*.

The following bridge deliverables shall be submitted to the Mobility Authority for review for each bridge structure:

- Preliminary (30%) Bridge Layout
- Intermediate (65%) Bridge Submittal
- Final (100%) Bridge Submittal
- Record Drawing Submittal

12.3.1.1 Preliminary (30%) Bridge Layout

The DB Contractor shall submit Preliminary Bridge Layouts for all temporary and permanent bridges for review. Boring logs as detailed in *Technical Provision 14* shall accompany each Preliminary Bridge Layout. With submission of Preliminary Bridge Layouts, the DB Contractor shall submit request for National Bridge Inventory (NBI) numbers to TxDOT.

Preliminary Bridge Layouts shall be prepared in accordance with preliminary data checklist provided in TxDOT *Bridge Detailing Guide*.

12.3.1.2 Intermediate (65%) Bridge Submittal

The DB Contractor shall submit Intermediate Bridge Submittal to the Mobility Authority for review concurrent with development of the Intermediate (65%) Design Submittal.

Intermediate bridge design packages shall include complete dimensional detailing of all bridge structural elements and include all detail design sheets. This shall include title sheets; bridge layouts; foundation layouts; foundation details and design tables; preliminary boring logs; abutment details; bent details; framing plans and elevations; span details, typical sections, and details; beam details and data sheets; typical details; deflection and camber diagrams; and other details as applicable. Packages shall list TxDOT bridge Standards, TxDOT (mod) standards, and project-specific standards to be used. Draft project-specific standards and TxDOT (mod) standards shall also be provided.

Intermediate bridge design packages shall be suitable for content and format review, and to allow other design disciplines to integrate bridge appurtenances into the respective submittals. It is not necessary to have structural design checks complete at this stage.

Individual detail sheet content shall be in accordance with applicable checklists provided in *TxDOT Bridge Detailing Guide*.

12.3.1.3 Final (100%) Bridge Submittal

Final (100%) Bridge Submittal shall include completed bridge layouts and final structural details for superstructure and substructure including all bridge appurtenances. Packages shall be in accordance with checklists provided in *TxDOT Bridge Detailing Guide*.

Design calculations shall be complete and checked, and shall be included with the Final (100%) Bridge Submittal. Final (100%) Bridge Submittal will not be considered complete if calculations are not available, incomplete, or unchecked.

12.3.1.4 Bridge Appurtenances

Final locations of permanent signs, lighting, and traffic signals will be determined by the DB Contractor in accordance with provisions of the Contract Documents. The design of bridges must provide for attachment of sign structures; hangers and attachments for utilities; drainage structures; and current or future conduit for traffic signals, lighting, intelligent transportation system (ITS), telecommunications, or other equipment. Hardware embedments shall be specified and located, and referenced to detail sheets for complete detailing of all structural appurtenances. Details shall include hangers, blockouts, and sleeve details for drainage, electrical, ITS, telecommunications, and other utilities.

12.3.1.5 Bridge Standard Drawings

Draft TxDOT (mod) and project-specific standards shall be provided with Intermediate Bridge Submittals. Submit such standards with the first Intermediate bridge package where standards apply. With the Final (100%) Bridge Submittal and Record Drawing Submittals, the DB Contractor shall submit a list of bridge standards for Mobility Authority review. Package shall clearly identify the version of each TxDOT standard to be used, describe proposed TxDOT (mod) standards, and describe project-specific standards.

A TxDOT (mod) standard is defined as a minor revision to a TxDOT standard drawing. Such standard remains on a TxDOT border file, with revisions clouded, numbered, and documented. The DB Contractor's Engineer-of-Record seals TxDOT (mod) standards. Significant sheet revisions should not be submitted as TxDOT (mod) standards.

A project-specific standard is any standard detail not covered by TxDOT Standards, or a significant modification to a TxDOT Standard, produced on the DB Contractor's drawing border file.

With the Final (100%) Bridge Submittal, the DB Contractor shall include all applicable standards. Drawing packages shall clearly specify which standards apply to each specific bridge installation. Notations designating applicable standards shall be included on all bridge packages. Completed TxDOT (mod) and

project-specific standards shall be submitted in advance of, or concurrent with the Final (100%) Bridge Submittal where such standards apply.

12.3.1.6 Record Drawing Submittal

The DB Contractor shall complete and submit Record Drawings in accordance with TxDOT computer-assisted drafting and design (CADD) standards and TxDOT bridge design standard practices. Bridge load ratings and indexed design calculations shall be included with Record Drawing submittals.

A record set of design calculations, including the checker's detailed documentation, shall be provided to the Mobility Authority within 30 Business Days of the Mobility Authority's acceptance of any Final Design Submittal.

12.3.1.7 Shop Drawings and Temporary Works Design

DB Contractor Responsibilities. Before fabrication of any structural element, the DB Contractor shall submit shop drawings to the Engineer-of-Record for review. Design, calculations, and drawing preparation for temporary works, such as shoring or falsework, are the responsibility of the DB Contractor. All temporary works shall be reviewed in the field by the Engineer-of-Record responsible for their design, for compliance with intent.

Project Records. Record copies of all shop drawings and temporary works documentation shall be submitted to the Mobility Authority before construction begins on each element.

12.3.2 Subsurface Investigations

The DB Contractor shall perform all subsurface investigations, and prepare Project Geotechnical Engineering Reports. Specific requirements for geotechnical investigation and reporting are addressed in Technical Provision 14.

12.4 Bridge Design Requirements

12.4.1 General Requirements

The DB Contractor shall meet the following design requirements.

Geometric Layouts. Number and width of lanes, shoulders, railings, sidewalks, and shared use paths shall comply with details shown on the Schematic Plan in Exhibit D – Item 3 – Technical (Roadway), Technical Provision 11 and shall meet all applicable TxDOT and AASHTO requirements. Further comply with Technical Provision 12.4.6 regarding accommodation of the Ultimate Design.

Locations and Heights. Modifications to bridge locations, extents, and heights as shown on the Schematic Plan in Exhibit D – Item 3 – Technical (Roadway) shall be shown in the Preliminary (30%) Bridge Layout submittals.

Load and Resistance Factor Design. Design shall be in accordance with AASHTO *LRFD Bridge Design Specifications* and TxDOT *Bridge Design Manual-LRFD*.

Vehicle Loads. All roadway bridges and bridge class culverts shall be designed to accommodate the following live loads:

- New Construction: HL-93 loading as defined in the AASHTO LRFD Bridge Design Specifications shall be utilized for bridges.
- Bridge Widening: HL-93 loading for widening and HS-20 loading for existing portion (designate both existing and widening loading on bridge layouts).

Design Life. All new bridges, and the widened portions of existing bridges, shall be designed to provide a 75-year design life after completion of construction.

Superstructures. The DB Contractor shall construct superstructures for bridges using new beams and girders fabricated from steel, prestressed concrete, or post-tensioned concrete. Used or salvaged beams shall not be permitted.

Bridge Decks. Concrete bridge decks on I-shaped concrete or steel girders shall be a minimum of 8 ½ inches thick. Concrete bridge decks on box beams or slab beams shall be a minimum of 5 inches thick. Prestressed concrete deck panels will be allowed, provided they comply with TxDOT Standards.

Materials. Unless written authorization from the Mobility Authority is provided, selection of materials shall be restricted to the following:

- Structural steel shall be ASTM A709, Grades 36, 50 or 50W.
- Concrete reinforcing steel shall be minimum Grade 60 (epoxy coating of reinforcing is not required). Up to Grade 80 reinforcing steel may be used in special circumstances with the prior written approval of the Mobility Authority.
- Prestressing steel shall be Grade 270 low-relaxation strands.
- Portland cement concrete shall comply with TxDOT Standard Specifications for Construction and Maintenance of Highways, Streets, and Bridges.

All materials provided shall be new; no salvaged materials are permitted.

Bridge Deck Joints. The DB Contractor shall minimize number of deck joints. Design and location of deck joints shall provide for maintenance accessibility and future replacement. All joints for bridge widenings shall be TxDOT standard sealed expansion joints (SEJ-M). Joints for all grade separation structures shall be sealed.

Local Roads. The transverse width of bridges carrying local roads over general purpose lanes shall, at a minimum, match the widths shown on the Schematic Plan in *Exhibit D – Item 3 – Technical (Roadway)*.

and also meet the requirements of Technical Provision 10 and its referenced attachments. Alignment shall meet desirable criteria indicated in TxDOT's *Roadway Design Manual* for the functional classification of each roadway.

Hydraulics. The DB Contractor shall design bridges over water to be serviceable following a 100-year flood event. The structure shall withstand a 500-year flood event without collapse in accordance with FHWA HEC-18 and HEC-23 design standards. The DB Contractor shall provide a scour assessment and protection for hydraulic conditions set forth in Technical Provision 15. To minimize hydraulic impacts, the DB Contractor shall design bridges at creek and river crossings such that all bents of all structures are aligned.

Bridge Deck Drains. Refer to Technical Provision 15 for bridge deck drain requirements.

Splices. Standard laps, or TxDOT-approved mechanical couplers, shall be used for all reinforcing steel splices and connections. Welding of rebar will not be permitted.

Welding. All welding shall comply with requirements of AASHTO/AWS *D1.5 Bridge Welding Code*.

Maintenance Inspection. The DB Contractor shall make all bridge superstructures, joints and bearings accessible for frequent and full life-cycle inspection and maintenance. The DB Contractor shall make box structures (steel, cast-in-place concrete, or concrete segmental box girders) with a minimum clear inside depth (height) of 6 feet 0 inches, to facilitate interior inspection. The DB Contractor shall include the access openings at maximum 600 feet spacing and the distance from any location of box girder to the nearest opening should not be more than 300 ft. There should be at least two access openings per box girder line. The access opening should be 32 inch x 42 inch or 36 inch in diameter at minimum with cover. Access covers shall open inward, and be accessible without impacting traffic below. All access covers shall be lockable. For maintenance requirements during construction, see Technical Provision 24.

Deck Forms. Precast, prestressed concrete deck panels in accordance with TxDOT Standards may be used for all bridges, except for curved steel girder bridges where approved stay-in-place formwork shall be used.

Aesthetics. Bridge aesthetics shall comply with details specified in this Technical Provision 12, and Technical Provision 10 and its referenced attachments.

Specific Design Requirements. Specific requirements for the design of bridges shall conform to the following specific parameters:

- Fracture-critical elements shall not be permitted.
- Load ratings of existing bridges to be widened shall be completed and submitted with the Preliminary (30%) Design Submittal. Rating shall be based on current TxDOT procedures. For replacement of existing railings on a widened deck, addition of utility loading or other specified loadings, the design shall not produce a net reduction in inventory, operating, or service load

rating of existing portions of the proposed structure without the Mobility Authority's acceptance.

- Underpass bridge bents located in general purpose lane medians shall be centered in the median, and aligned with the roadway baseline, to accommodate future widenings.
- End slopes and side slopes at bridge ends shall be no steeper than 3:1 (horizontal to vertical) unless approved in writing by the Mobility Authority.
- Widened bridge approaches shall match existing bridge approach types. The DB Contractor shall use concrete approach slabs on all bridges with cement-stabilized abutment backfill (CSAB) behind the abutment backwall. Approach slab design shall conform to TxDOT Standards.
- AASHTO *LRFD Bridge Design Specifications* and the TxDOT *Bridge Design Manual – LRFD* require accounting for vehicular collision force through enhanced column design, or via barrier protection. Barriers shall not be used to satisfy this requirement.
- The DB Contractor shall proportion bridge spans to avoid uplift at supports.
- Minimum vertical clearance of 16 feet 6 inches min is required for all bridge widenings unless the existing condition is less than 16 feet 6 inches. For existing bridge structures less than 16 feet 6 inches, bridge widening shall not reduce the existing vertical clearance. The portion of any structure over a U-Turn shall meet vertical clearance requirements in *Exhibit C - Attachment 11-1*.

McNeil Drive Bridge. Specific design requirements for widening of this bridge are as follows:

Allowed:

- A multiple simple-span arrangement, provided all girders have a constant depth, from abutment to abutment.
- Pavement and drainage modifications as needed to achieve minimum vertical clearances over the cross street.

Not Allowed:

- Matching the existing drop-in girder structural system.
- Variable-depth girders.
- Longitudinal joint longer than the existing girder cantilever plus five feet.
- Concrete girders with dapped end.
- Longitudinal joint in a travel lane.

Required:

- Deflection (stiffness) compatibility with the existing cantilever/drop-in arrangement.
- Longitudinal thermal movement compatibility with the existing cantilever/drop-in arrangement.

Lakeline Mall Drive bridge. Specific design requirements for widening of this bridge are as follows:

Allowed:

- The reuse of existing retaining walls and abutments including existing drilled shafts, caps, and backwalls between the NB and SB bridges, provided that the DB Contractor shall demonstrate that the existing abutment satisfies the HS 20 loading requirement according to the AASHTO Standard Specification for Highway Bridges (17th Edition) in the proposed configuration.
- Addition of bearing seats.

Not Allowed:

- Reduction of the existing abutment cross-sectional dimensions including existing caps and backwalls.

12.4.2 Beams and Girders

For prestressed concrete girders, maintain constant girder depths throughout bridge length. For steel girders, maintain constant web depth within and between girder units, except for dapping the girders at ends of units, if required.

The exterior girder centerlines in the adjacent spans shall line up when they intersect with the bent centerlines to create a smooth exterior girder alignment.

12.4.3 Foundation Design

Foundation type, foundation capacities, drilled shaft and piling lengths, and bottom of footing elevations are to be determined by the DB Contractor.

Abutments and Bents. Drilled shaft size and spacing for abutments and conventional bents shall follow the recommendations found in the TxDOT *Bridge Detailing Guide*, TxDOT *Bridge Design Manual – LRFD* and TxDOT Standards. Integral abutments shall not be permitted. Foundations may include drilled shafts or driven piles for both abutments and bents.

Spread Footings. Spread footings shall not be permitted.

Approach Slabs. The DB Contractor shall use concrete approach slabs on all bridges. Approach slab design shall conform to TxDOT Standards.

Pile Report. When driven piles are used, the DB Contractor shall complete a piling report for each structure and shall submit to the DB Contractor’s Engineer-of-Record for review and approval prior to placing pile caps. A record copy of piling reports shall be concurrently submitted to the Mobility Authority. Pile reports shall be in a format similar to that found in the “Site Manager Forms” portion of the TxDOT website.

Drilled Shaft Report. When drilled shafts are used, the DB Contractor shall complete a drilled shaft report for each structure and shall submit to the DB Contractor’s Engineer-of-Record for review and approval, prior to placing abutment caps, shaft caps, or columns. A record copy of drilled shaft reports shall be concurrently submitted to the Mobility Authority. Drilled shaft reports shall be in a format similar to TxDOT form 1257 Work Report which is available on the TxDOT website. Thermal Integrity Profiler (TIP) testing shall be performed on all drilled shafts with diameters larger than 66 inches. The TIP testing shall be performed in accordance with TxDOT Special Specification 4021. Alternatively, shaft integrity testing may be performed using Crosshole Sonic Logging (CSL) techniques in accordance with ASTM D6760. Integrity testing requirements of all drilled shafts 66 inches or smaller in diameter will be at the discretion of the DB Contractor.

12.4.4 Bridge Bearings

Standard TxDOT bearings shall be used for all bridges except where expansion length, load, or friction forces renders their use impractical. All bearings shall be reinforced elastomeric bearings or sliding elastomeric bearing pads. Design of elastomeric bearings shall conform to AASHTO *LRFD Bridge Design Specifications* as modified by provisions of TxDOT *Bridge Design Manual – LRFD*. Tapered elastomeric pads will be allowed for precast prestressed concrete girders per TxDOT standards, and shall meet TxDOT durometer test procedures.

12.4.5 Bridge Railing and Barriers

Bridge rail and barrier systems shall conform to standards established by TxDOT and meet AASHTO and FHWA requirements.

Standard Bridge Rails. The DB Contractor shall use either TxDOT standard bridge rails, or modified rails if specified in and *Technical Provision 10* and its referenced attachments.

Alternate Barriers. Only alternate barrier systems crash tested and accepted by the FHWA for use on the NHS shall be used. Alternate barrier systems shall only be used with acceptance from the Mobility Authority. Alternate barriers shall meet Testing Level (TL) requirements, as defined by NCHRP Report 350, for standard TxDOT barriers.

12.4.6 Accommodation of Ultimate Design

The DB Contractor shall design all structures near the interchange of RM620/SH45, and near the intersection of Pond Springs Road, to accommodate ultimate direct connector bridges, walls, and foundations (refer to Reference Information Documents) such that:

- Common equipment, such as drilling rigs and cranes, can be used with minimal or no special accommodations.
- Demolition or replacement of work installed by the end of this contract is not required.

The DB Contractor shall further design drainage systems and underground utilities to accommodate these ultimate direct connector foundations, such that demolition or replacement of work installed by the end of this contract is not required.

The DB Contractor shall demonstrate compatibility with the Ultimate Design, starting with Preliminary submittals for bridges and walls.

12.5 Retaining Walls

Where possible, the DB Contractor shall design and construct embankments or cut slopes within required side slope limits without the use of retaining walls. Where limits for side slopes would be exceeded, the DB Contractor shall use retaining walls. The proposed retaining wall system shall be submitted no later than with the first Preliminary (30%) Design Submittal retaining wall layouts. The DB Contractor shall not use steel modular walls or concrete block retaining walls.

Aesthetics. Retaining wall aesthetics shall comply with details specified in this *Technical Provision 12*, and *Technical Provision 10* and its referenced attachments.

Wall design shall be in accordance with AASHTO *LRFD Bridge Design Specifications*.

Retaining walls in fill sections shall have a minimum embedment of 2 feet below finished grade. Slopes extending from the base of retaining walls shall not be steeper than 4H:1V.

The following slope requirements at retaining walls shall be met unless otherwise approved by the Mobility Authority. A 1% slope shall extend from the base of wall for a minimum distance of 2 feet where the slopes extending from the base of the wall are flatter than 4H:1V. Extend the 1% slope a minimum of 4 feet where the walls are on a slope extending from the base of the wall at 4H:1V. Slopes extending above the top of a fill wall shall not be steeper than 6H:1V. Slopes extending above the top of a cut wall shall not be steeper than 4H:1V. Slopes extending from the base of a walls used also as barriers, such as between general purpose lane directions, or between express and general purpose lanes, shall not be steeper than 10H:1V.

Detailed slope stability analyses using site-specific subsurface information are required for all retaining walls, and when subsurface conditions, retained zone configuration, or surcharge loads vary significantly within the limits of the wall. The designer shall verify external stability of retaining walls, which shall include sliding, overturning, bearing, settlement, and global (rotational) stability, under both wet and dry conditions. Unit weights for reinforced zone material shall be assumed to be 10% less than typical, when checking sliding and overturning.

All retaining walls shall use a resistance factor of 0.65 for global stability checks. Global stability analyses shall include non-circular optimized surfaces in clay soils, and shall consider both effective and total stress soil parameters. External stability of the wall is a function of the retained zone materials (those placed behind the reinforced zone), and the retained zone properties used in construction must be consistent with that used for design. The designer shall specify the minimum soil gradation (and any other required properties) for the retained zone fill.

Prior to production use, mock-up samples of retaining wall system panels and coping shall be made available for Mobility Authority review. Mockups shall employ elements of the same size, shape, color, and texture as production elements, and shall comply with Technical Provision 10 and its referenced attachments.

- All retaining walls shall fit into one of the following categories:
- Cast-in-place concrete construction - applicable to cantilever retaining walls and median barriers with earth retention.
- Drilled concrete shaft retaining walls.
- Soldier pile walls.
- Tieback walls (anchored walls).
- MSE retaining wall systems, engineered by and supplied from the current TxDOT list of approved MSE vendors.
- Soil nail or rock nail walls, with permanent concrete facing.

All retaining walls bordering grass or vegetation shall have a minimum 2-foot-wide mow strip along the finish grade, adjacent to the finished wall face.

Where non-paved surfaces are adjacent to the top of walls, a concrete lined flume no less than 2 feet wide shall be installed to capture runoff and convey that runoff to an appropriate outfall location. Flumes shall be permanently attached to the top of wall or coping, to prevent separation.

An approved concrete traffic barrier shall be installed at the top of retaining walls, when adjacent to roadway pavement, or when the top of wall is within the clear zone and not already protected by a traffic barrier.

The traffic barrier must be designed to resist standard rail impact loadings. A pedestrian railing at the top of walls will not be required for walls outside of the clear zone that do not have a nearby pedestrian facility.

MSE Retaining Walls. The DB Contractor shall use only one MSE retaining wall system for the entire project. MSE walls shall not be used to support bridge abutments, or abutment foundations.

The DB Contractor's design of MSE abutment walls shall include 4 feet of clearance between back of wall panels and face of abutment foundations to allow for proper strap arrangements, unless it can be demonstrated that smaller offsets are workable. The proposed offset dimension and example details shall be submitted no later than with the first Preliminary (30%) Design Submittal retaining wall layouts.

MSE retaining walls shall meet the requirements of TxDOT Standard RW (MSE). TxDOT Standard RW (MSE) DD shall be completed for all walls. When changing subsurface conditions and varying wall heights require multiple slope stability designs, more than one entry into RW (MSE) DD will be required per wall.

Live Load Surcharge. The DB Contractor shall provide for live load surcharges on walls in accordance with provisions of AASHTO *LRFD Bridge Design Specifications*.

Design Life. Retaining walls shall be designed to provide a 75-year life after completion of construction. Earth reinforcement elements, related panel connections, and panels shall have corrosion resistance and durability to ensure 75-year life. Reinforcement element loss per side due to potential corrosion shall be computed by assuming a uniform loss model as follows:

Zinc Corrosion Rate (First 2 years)	15 $\mu\text{m}/\text{yr}$
Zinc Corrosion Rate (subsequent years)	4 $\mu\text{m}/\text{yr}$
Carbon Steel Corrosion Rate	12 $\mu\text{m}/\text{yr}$

Weep Holes. No weep holes or drains that penetrate the exposed or visible face of retaining walls shall be allowed.

Underdrains. Underdrains are required on all MSE walls and shall be a minimum of eight inches with cleanouts at a maximum of 300-foot spacing unless an alternative is approved by the Mobility Authority. Underdrains shall be sloped to drain to permanent outfalls. Outfalls and the flowlines shall be shown on the retaining wall layouts.

Temporary Shoring Requirements. Provide vertical temporary special shoring for the construction of MSE retaining walls, as required. The DB Contractor shall demonstrate how new walls will be constructed in close proximity to existing walls, using temporary special shoring or other means, while maintaining traffic movements consistent with the DB Contractor's MOT plans.

Pipe Culverts. If pipe culverts are to extend through the retaining walls, the pipe shall be installed so that no joints in the pipe are located within two (2) feet of face of wall. Slip joints shall be placed on either side

of the pipe and a headwall shall be placed over the portion of the pipe exiting the wall when any portion of the pipe exits the wall above finished ground.

12.6 Drainage Structures

All drainage structures shall be designed to comply with requirements of *Technical Provision 15*. The DB Contractor shall analyze existing drainage structures intended to remain, for capacity to accommodate any additional loads, settlements, and/or other structural impacts associated with new work.

Design. New drainage structures subject to highway loading, and extensions/capacity enhancements to existing structures subject to highway loading, shall be designed to accommodate HL-93 loading.

Design Life. The DB Contractor shall design all culverts for a 75-year life.

Energy Dissipaters. All energy dissipaters shall be considered structural elements.

Submittals. Draft structural details shall be submitted to the Mobility Authority concurrent with the Preliminary (30%) Design Submittals, and Intermediate (65%) Design Submittals. Final structural details shall be provided with the Final (100%) Design Submittals. Drainage structural details shall accompany drainage submittal packages sufficient to identify location and function of each detail.

Identifiers. All culverts shall be identified on drainage plans by general purpose lane centerline station and size. For bridge class culverts, the DB Contractor shall submit request for National Bridge Inventory (NBI) numbers to TxDOT. Bridge class culverts are defined as having a clear opening of more than 20 feet between the extreme inside faces as measured along the highway centerline.

12.7 Structural Sign Supports

Sign Supports. Structural design of sign supports shall be in accordance with AASHTO *Standard Specifications for Structural Supports for Highway Signs, Luminaires, and Traffic Signals*.

Non-Sign Supports. Structural design of high-mast lighting poles, mast arms, and strain poles for traffic signal supports shall be in accordance with AASHTO *Standard Specifications for Structural Supports for Highway Signs, Luminaires, and Traffic Signals*.

Locations. The DB Contractor shall accommodate the ultimate roadway design in placement of overhead and cantilever sign supports. Clear zone requirements shall be met for work under this scope, as well as for future lanes identified on the Ultimate Schematic Plan. Overhead sign column locations shall be submitted to the Mobility Authority for review, beginning with the first Preliminary (30%) Design submittals. The Mobility Authority reserves the right to reject overhead sign column locations that require barrier and/or guardrail protection, due to encroachments on the clear zone, unless such columns are located in the median between general purpose lanes, or on bridge bents. Acceptance of column locations will not be granted based solely on cost and schedule.

12.8 Other Bridge Structures

Temporary Vehicular Bridges. Temporary vehicular bridges shall be designed using AASHTO *LRFD Bridge Design Specifications* and AASHTO *Guide Design Specifications for Bridge Temporary Works*.

12.9 Existing Bridge Structures

The most current bridge condition ratings for each of the existing bridge structures to be widened or to remain in service are provided in *Exhibit C – Attachment 12-1 – Bridge Condition Rating Summary*. Ratings of any kind, for any element, of less than 7 (out of 9) shall be considered deficient. The DB Contractor shall propose draft repair and restoration details for each deficiency on each bridge and bridge class culvert, beginning with the first Preliminary (30%) Design submittals. All repair techniques shall conform to published TxDOT recommendations, current at time of proposal.

The DB Contractor shall conduct bridge inspections for all existing bridges and bridge class culverts and confirm rehabilitation has achieved a minimum condition rating of 7 for each structural component at Substantial Completion. The inspections shall be performed by inspectors, pre-approved by TxDOT, with previous experience inspecting TxDOT bridge inventory.

The DB Contractor shall clean and repair existing expansion joints and provide new seals full width of existing and widened structures including all existing open joints.

The DB Contractor shall inspect all existing bridge bearings. As necessary, the DB Contractor shall rehabilitate, repair, or replace existing bridge bearings to accommodate design loads and expansion.

The DB Contractor shall patch and repair concrete spallings, concrete delaminations, clean and repair exposed reinforcing, seal cracks and repair or replaced structurally damaged elements of existing structures.

Bridge Condition Ratings. A Bridge Condition Rating Summary is provided for existing bridges and bridge class culverts in *Exhibit C – Attachment 12-1 – Bridge Condition Rating Summary*. This section is not intended to replicate the full condition survey information; the DB Contractor shall use this section only as supplemental information.

Lead and Asbestos Reports. Lead and Asbestos Reports are provided in *Exhibit D – Item 3 – Technical (Structural)*.

12.10 Submittals

Table 12-1: Submittals to Mobility Authority

Submittals	Submittal Schedule	Mobility Authority Action	Reference Section
Preliminary Bridge Layouts	Concurrent with development of the Preliminary (30%) Design Submittal	Acceptance	12.3.1.1
Intermediate Bridge Layout	Concurrent with development of the Intermediate (65%) Design Submittal	Acceptance	12.3.1.2
Final (100%) Bridge Layout	Concurrent with development of the Intermediate (65%) Design Submittal	Acceptance	12.3.1.3
Draft TxDOT (mod) and Project-Specific Standards	With Intermediate Bridge Submittals	Acceptance	12.3.1.5
List of Bridge Standards	With the Final (100%) Bridge Submittal and Record Drawing Submittals	Acceptance	12.3.1.5
Record Drawings	Within 30 Business Days of the Mobility Authority's acceptance of any Final Design Submittal	Information	12.3.1.6
Shop Drawings and Temporary Works Documentation	Before construction begins on each element	Information	12.3.1.7
Copy of Piling Reports	When driven piles are used	Information	12.4.3
Copy of Drilled Shaft Reports	When drilled shafts are used	Information	12.4.3
Draft Drainage Structural Details	Concurrent with: Preliminary (30%) Design Submittals, and Intermediate (65%) Design Submittals	Acceptance	12.6
Final Drainage Structural Details	With the Final (100%) Design Submittals	Acceptance	12.6

Table 12-1: Submittals to Mobility Authority

Submittals	Submittal Schedule	Mobility Authority Action	Reference Section
Overhead Sign Column Locations	Beginning with the first Preliminary (30%) Design submittals	Acceptance	12.7

13.0 PERMANENT SIGNING DESIGN

13.1 Referenced Standards and Guidelines

The DB Contractor shall comply with the most current edition, unless otherwise specifies, of the following standards for permanent signing design, unless otherwise directed by the Mobility Authority:

- AASHTO Standard Specifications for Structural Supports for Highway Signs, Luminaires, and Traffic Signals
- AASHTO A Policy on Geometric Design of Highways and Streets
- Texas Manual on Uniform Traffic Control Devices (TMUTCD)
- TxDOT Roadway Design Manual
- TxDOT Standard Specifications for Construction and Maintenance of Highways, Streets, and Bridges
- TxDOT Freeway Signing Handbook
- TxDOT Signs Guidelines and Applications Manual
- TxDOT Standard Highway Sign Design for Texas
- TxDOT Engineering Standard Plan Sheets
- TxDOT Sign Crew Field Book

13.2 Performance Requirements

The DB Contractor shall be responsible for designing and constructing permanent signage in accordance with the requirements identified in this Technical Provision 13.

The DB Contractor shall design and install all toll, guide, warning, regulatory, bicycle, and shared use signs in accordance with TxDOT Standards, the TMUTCD and/or MUTCD, with the requirements identified in this Technical Provision 13, and Exhibit C – Attachment 10-1 – 183 North Mobility Project Aesthetic Design Guide. Final location, text, and appearance of all signage shall be subject to the Mobility Authority's approval.

Small signs that are impacted by construction activities or are no longer serviceable must be replaced with new materials by the DB Contractor.

For maintenance requirements during construction, see Technical Provision 24.

Aesthetics Guidelines. Permanent sign structures shall be aesthetically treated in accordance with *Exhibit C – Attachment 10-1 – 183 North Mobility Project Aesthetic Design Guide*. Large overhead sign layouts shall provide uniform spacing between signs and center signs over the roadway unless the sign is required to be placed in a specific location per design standards and guidelines referenced in *Technical Provision 13.1*.

Extent of Review. The permanent signing for this Project shall incorporate guide signing, tolling signing, regulatory signing, warning signing, logo signing, destination signing, while meeting aesthetic guidelines for the Project. As such, the DB Contractor shall anticipate an extensive review process from the Mobility Authority that shall include coordination with TxDOT on specific roadways. The DB Contractor shall be prepared to provide revisions to the signing plans to resolve all review comments to the satisfaction of the Mobility Authority.

Layout Requirements. Signing plans (described in detail in *Technical Provision 13.7*) shall include the layouts showing the locations of ground mounted and overhead signs, special sign details, legend, sign lighting, and structural and foundation requirements. Any requirements for electric service shall be coordinated with the applicable Utility Owners and provided by the DB Contractor. Placement of signs shall not impede the operation of CCTV cameras or tolling equipment.

13.3 Roadway Sign Design Criteria

General. The sign system shall:

- Provide uniformity in shape, color, dimensions, legends, illumination, and reflectivity with other highway signs within the Project corridor including the general purpose lanes in this corridor.
- Provide adequate time for appropriate motorist response to signs.
- Facilitate sign maintenance and servicing.

13.3.1 Existing Signs

General. To avoid motorist confusion, the DB Contractor shall remove, cover, or (if to be reused for temporary signs) salvage existing signs that conflict with the regulation of traffic through Project construction and final configuration or are no longer applicable because of construction sequencing or staging.

Ground-Mounted Signs. All ground-mounted existing signing on U-channel signposts (except for existing general purpose lanes signing) impacted by the project shall be removed and will become the property of the DB Contractor to dispose of and replace as required. Small ground-mounted signs shall be replaced by new signs of the same or comparable type, provided that the sign contents remain applicable

Overhead Signs. All overhead sign structures and signs identified for replacement shall become the property of the DB Contractor for its disposal.

Conduit, Cable, and Switches. If any existing sign structures are to be reused for temporary signs, the DB Contractor shall remove them and dispose of all conduit, cable, and safety switches.

Sign Lighting and Ballasts. Existing sign lighting fixtures and ballasts on existing overhead and bridge-mounted sign structures that have been identified for removal shall be dismantled and hauled by the DB Contractor to the appropriate agency. Advance notice of at least 3 Business Days shall be given to agency before hauling, and materials shall be deposited where and as directed by agency personnel.

13.3.2 Sign Construction and Placement

General. The DB Contractor shall:

- Provide positive guidance to the traveling public at all times during construction by the use of existing, interim, and new signing to ensure safe and informed operation while traffic is maintained on the roadway. See Technical Provision 22.
- Furnish and install all new signs, posts, foundations and associated materials.
- For all , structures, fabricate and install walkway systems, as well as any other necessary facilities such as conduit and cabling pursuant to Technical Provision 18, to accommodate proposed toll signing, future sign lighting and future ITS equipment.
- For new overhead sign structures, provide sufficient height to ensure desirable clearance which meets TxDOT Standards for clearance above the roadway.
- At least 30 days prior to installation, the DB Contractor shall conduct a construction design review meeting with the Mobility Authority to address the phased implementation of sign installation on the project.

No Reuse. Excluding existing overhead signs to remain, the DB Contractor may not reuse any existing sign materials or structures as part of the new permanent signing installation.

Interim Signing. The Maintenance of Traffic (MOT) plan submitted by the DB Contractor must address the use of interim signing during the transition from existing to new signing; see Technical Provision 22. If signs are erected above or adjacent to an active roadway before the stated condition exists, they shall be covered securely with a durable material. This cover shall be bolted to the sign with a minimum of 0.125-inch thick plastic washers between the sign face and the cover.

Business Guide Signing. The DB Contractor's attention is directed to Technical Provision 22 for business guide signing requirements during construction.

Reference Markers. The DB Contractor shall place reference markers and/or mile markers at approximately one mile apart in accordance with the TRM system along the general purpose lanes. The DB Contractor shall also place reference markers and/or mile markers at approximately one-half mile apart along the express lanes. The DB Contractor shall set reference markers and/or mile markers according to the TMUTCD. Once placed, the DB Contractor shall inventory and record reference markers with GPS. The DB Contractor shall provide this information to the Mobility Authority in Microsoft Excel format.

13.3.3 Maintenance During Construction

The DB Contractor shall be responsible for maintenance of all signs during the Project construction until Final Acceptance, including (but not limited to):

- Repair and replacement of damaged signs, as required.
- Cleaning away dirt and other debris from signs, as required.
- Moving and relocating guidance and warning signs as required for the safe and efficient movement of traffic.

13.4 Guide Sign Design Criteria

Signs Outside Project Limits. The DB Contractor shall design and install guide signs outside of the Project limits but within public ROW. The scope of the Work for signs located outside of the Project limits within public ROW controlled by other local or State agencies includes new signs and modifications to existing sign panels and structures where existing signs conflict with the Project plans. This shall include sign changes necessary due to altered access to the Project from adjoining facilities. The DB Contractor shall coordinate sign removals and replacements in existing public ROW with the appropriate governmental entities.

Agency Coordination. The DB Contractor will install signs located outside of the Project in existing ROW controlled by other local or State agencies. The DB Contractor shall coordinate with applicable governmental agencies for the design and installation of the guide signs outside of the Final ROW in existing ROW controlled by other local or State agencies as required for the Project.

Sign Locations. The DB Contractor shall install signs in accordance with the sign schematic submitted to the Mobility Authority by the DB Contractor.

Use of Logo. The Mobility Authority will furnish the DB Contractor a graphic design of the current Mobility Authority logo or logos as well as other artwork that the DB Contractor shall integrate into the design and fabrication of guide signs.

13.5 Advance Toll Sign Design Criteria

Toll Sign Location. The DB Contractor shall design and install advance toll signs within the Project limits in accordance with the current TxDOT standards and the TMUTCD. Signs shall be located in such a manner that they do not conflict with other signs, vegetation, or structures and are clearly visible according to TMUTCD standards. The DB Contractor Work shall include:

- Determination of sign locations.
- Installation of new signs.
- Determination of sign foundations.
- General criteria to be used by the DB Contractor in determination of advance toll sign locations for the Project are as follows:
 - At all locations where existing cross roadways provide the traveling public access to the Project.
 - Prior to all entrance ramps to the Project.

Layout Submittal. The DB Contractor shall provide the Mobility Authority with a signing schematic layout as part of the Permanent Signing Concept Report described below in *Technical Provision 13.7.1* indicating the final locations of all advance toll warning signs. The Mobility Authority will review and provide comments to the DB Contractor prior to any fabrication or construction.

Final design details for all toll signs shall be approved by the Mobility Authority.

13.6 Third Party Signs

In addition to the warning, regulatory, and guide signs within the Project limits, the Mobility Authority may request that supplemental signs be installed by a third party. The DB Contractor shall coordinate and cooperate with any third party performing such Work. The Mobility Authority will have the sole responsibility for reviewing applications for new supplemental signs and for approving permits to install these signs. The cost for fabricating and installing these signs shall be borne by the sign applicant.

13.7 Signing Reports and Plans

The DB Contractor shall provide submittals in accordance with **Table 13-1** and as described below.

13.7.1 Permanent Signing Concept Report

PSCR Submittal. At least 4 weeks before beginning the intermediate design of the permanent signing, the DB Contractor shall submit to the Mobility Authority a Permanent Signing Concept Report (PSCR) that outlines the proposed permanent signing design. This is a concept report and the final signing design will not be considered complete until acceptance of the Final (100%) Design Submittal.

Signing Schematic. Preliminary signs are shown on the Schematic Plan in *Exhibit D – Item 3 – Technical (Roadway)* for information only. As a part of the PSCR Submittal the DB Contractor shall provide the Mobility Authority with an updated sign schematic indicating the locations of all guide signs and advance toll signs and detailing the following at minimum:

- Existing signs to remain
- New toll message sign installations along the Project.
- New sign installations on the Project.
- Modification or relocation of existing signs along US 183 and Loop 1.
- New, relocated, or existing dynamic message signs.
- New signs and replacement signs on intersecting roadways and intersections.
- New signs and replacement signs along sidewalks and shared use path (pedestrian/bicycle) facilities.

The sign schematic is subject to the joint review and approval by the Mobility Authority and TxDOT. The DB Contractor shall design and install all signs along the Project. The DB Contractor will install signs located outside of the Project limits in public ROW controlled by other local or State agencies as required for the Project.

Contents. The DB Contractor shall provide the following information:

- Sign locations.
- Sign text layout.
- Panel size.
- Proximity to ITS devices, including overhead CMS locations and CCTV locations.
- Types of proposed sign structures.
- Proximity to logo sign structures.
- Aesthetic concerns.
- Destinations on guide signing.
- Business signing.
- Interim signing requirements during construction.
- Analysis of signal system mast arm loading for mast-arm-installed signs.
- Analysis of overhead bridge mounted signs.

Design Meetings. During PSCR development, the DB Contractor shall meet with staff of the Mobility Authority, TxDOT, local municipalities, and county staff having jurisdiction over the Project corridor in developing the PSCR to discuss goals and parameters of the permanent signing design. This will include (but not be limited to) destinations shown on the guide signing and the businesses that will be provided signing.

13.7.2 Permanent Signing Plans

The DB Contractor shall prepare a set of plans incorporating the permanent signing and pavement markings. The DB Contractor shall provide these plans as a part of the Intermediate (65%) Design Submittal, Final (100%) Design Submittal, and Final Design Package, subject to the requirements of Technical Provision 2.

DQAM Certification. With its submittal of the permanent signing plans, the DB Contractor shall provide certification from the Design Quality Assurance Manager (DQAM) that the submittal meets the Project requirement as outlined in Technical Provision 2.

Contents. The plan submittals shall include (but are not limited to) the following:

- Design drawings showing type and location (station and offset) of the standard signs, including all existing signs to remain and any to be removed.
- Design drawings showing dimensions and locations of text, arrows, logos, or other sign legend elements on all sign panels having custom design (guide sign detail sheets).
- Design drawings (other than TxDOT Standard Drawings) showing details of sign mounting, foundations, base connections, frames, and other related equipment, cross sections, etc..
- For each ground-mounted sign with I-beam posts and for each overhead sign structure, depiction of a cross section, with indication of footing details, offsets, and mounting heights.

Shop Drawings. All manufacturer-furnished shop drawings shall be reviewed by the DB Contractor for adequacy before their submittal for Mobility Authority review.

13.8 Submittals

Table 13-1: Submittals to Mobility Authority

Submittals	Submittal Schedule	Mobility Authority Action	Reference Section
Permanent Signing Concept Report (PSCR)	At least 4 weeks before beginning of Intermediate Design	Acceptance	13.7.1
Signing Schematics	As part of PSCR	Acceptance	13.7.1
Permanent Signing Plans	As part of: (1) Intermediate (65%) Design Submittal, (2) Final (100%) Design Submittal, (3) Final Design Package	Acceptance	13.7.2
Design Quality Assurance Manager (DQAM) certification	As part of the Permanent Signing Plans	Concurrence	13.7.2

14.0 GEOTECHNICAL DESIGN REQUIREMENTS

The DB Contractor shall be responsible for geotechnical Work in accordance with the requirements identified in this *Technical Provision 14*.

General. A limited number of geotechnical borings have been performed within the Project limits as documented in the geotechnical report provided in *Exhibit D – Item 3 – Technical (Geotechnical)* and the Pavement Design Report for the Project in *Exhibit D – Item 3 – Technical (Pavement)*. Each boring identifies the subsurface conditions at its specific location at the time and under the conditions existing at the time the information was obtained.

The geotechnical data provided by the Mobility Authority shall not be the sole source for design and must be supplemented by a comprehensive geotechnical investigation for the project. The DB Contractor shall develop a detailed boring program to supplement the geotechnical report provided in *Exhibit D – Item 3 – Technical (Geotechnical)*. The DB Contractor shall produce final geotechnical report in accordance with the requirements of this *Technical Provision 14*. The DB Contractor shall be responsible for obtaining permission to enter properties not under Mobility Authority control and shall obtain all Governmental Approvals necessary for geotechnical investigations, including clearance for all Utilities and all Governmental Approvals required for access road grading, temporary fill of jurisdictional waters of the US or State (including wetlands), drilling permits, and groundwater protection from inter-aquifer contamination. The DB Contractor shall also be responsible for any mitigation or restoration associated with its geotechnical investigation program.

The DB Contractor shall provide temporary traffic control in accordance with the requirements of *Technical Provision 22*.

14.1 Standards and Guidelines

In conducting geotechnical investigations, analysis, and design, the DB Contractor shall adhere to requirements in this *Technical Provision 14* and other parts of the Contract Documents, using the following, as modified by TxDOT design practices:

- AASHTO Standard Specifications for Highway Bridges
- AASHTO LRFD Bridge Design Specifications (BDS) 2017 8th edition with the current interim revisions
- AASHTO Manual on Subsurface Investigations
- AASHTO T088-00, Particle Size Analysis of Soils
- AASHTO T089-02, Determining the Liquid Limit of Soils

- AASHTO T090-00, Determining the Plastic Limit and Plasticity Index of Soils
- AASHTO T100-06, Specific Gravity of Soils
- AASHTO T208-05, Unconfined Compressive Strength of Cohesive Soil
- AASHTO T216-07, One-Dimensional Consolidation Properties of Soils
- AASHTO T226-90 or ASTM D7012-14, *Shear Strength Testing of Rock*
- AASHTO T265-93, Laboratory Determination of Moisture Content of Soils
- AASHTO T267-86, Determination of Organic Content in Soils by Loss on Ignition
- AASHTO T297-94, Consolidated, Undrained Triaxial Compression Test on Cohesive Soils
- ASTM D1586-08, Standard Penetration Test (SPT) and Split-Barrel Sampling of Soils
- ASTM D1587-08, Thin-Walled Tube Sampling of Soils for Geotechnical Purposes
- ASTM D2113-08, Rock Core Drilling and Sampling of Rock for Site Investigation
- ASTM D2488-09a, Standard Practice for Description and Identification of Soils (Visual-Manual Procedure)
- ASTM D3080-11 or ASTM D7181-11, Shear Strength Testing of Cohesionless Soils
- ASTM D7012-14, Unconfined Compressive Strength of Rock
- FHWA, Drilled Shafts: Construction Procedures and Design Methods, FHWA GEC 010
- FHWA Geotechnical Engineering Circular No. 4, Ground Anchors and Anchored Systems, IF-99-015
- FHWA Geotechnical Engineering Circular No. 5, Evaluation of Soil and Rock Properties, IF-02-034
- FHWA Geotechnical Engineering Circular No.7, *Soil Nail Walls*, FHWA-NHI-14-007
- FHWA Subsurface Investigations – Geotechnical Site Characterization, Reference Manual, NHI-01-031TEX 132-E, Texas Cone Penetration Test
- TxDOT Geotechnical Manual
- TxDOT Standard Specifications for Construction and Maintenance of Highways, Streets, and Bridges

14.2 Subsurface Investigation

14.2.1 General Requirements

The DB Contractor shall perform a comprehensive subsurface investigation. Specific locations, frequency, and scope of subsurface investigation shall be determined by the DB Contractor, but shall meet minimum

requirements of this *Technical Provision 14*, and comply with requirements of the TxDOT *Geotechnical Manual*.

General Locations. The DB Contractor shall perform borings and laboratory tests as necessary for the Project Design.

Investigation Tasks. In its subsurface investigation, the DB Contractor shall:

- Review preliminary plans, temporary staging plans and perform on-site inspection.
- Determine location of test boring and type of sampling required.
- Perform soil borings.
- Perform Standard Penetration Test (SPT) and/or Texas Cone Penetration (TCP) Test.
- Obtain undisturbed soil samples and perform laboratory tests.
- Obtain rock core samples, if required.
- Measure groundwater levels.
- Maintain field boring logs and document drilling and testing in final boring logs.

Property Access. Before taking any borings on private property, the DB Contractor shall obtain permission from property owner.

Utility Clearance. Before performing borings, the DB Contractor shall contact utility companies and ensure that no in-place utility structures will be encountered. The DB Contractor shall be responsible for any claims resulting from damage to any utility structures, both above and below ground.

Traffic Control. Before commencing Work within TxDOT, County, or Municipal ROW, the DB Contractor shall notify the Mobility Authority. The DB Contractor shall provide temporary traffic control in accordance with TMUTCD requirements and jurisdictions where boring operations are conducted.

Deliverables. Before commencing Work, the DB Contractor shall submit its Subsurface Investigation Plan, which will include a narrative of field procedures to be followed. The plan shall also include contact information for responsible parties, procedures for utility clearance, planned borehole depths, procedures for borehole abandonment, and a schematic showing the approximate location of the planned borings. The plan shall include a health and safety plan for all geotechnical Work within the Project corridor.

14.2.2 Review and Inspection

Review of Plans. The DB Contractor shall conduct a general engineering reconnaissance to inspect site soil and geologic conditions in the vicinity of proposed soils borings, and general locations of Project structures with regard to existing roads and waterways.

On-Site Inspection. The DB Contractor shall conduct a general engineering reconnaissance to inspect site soil and geologic conditions in the vicinity of the proposed boring locations or as directed by the Mobility Authority. The DB Contractor shall record performance of existing embankments, differential settlements, foundation failures, active landslides, bedrock exposure, limits of questionable foundation areas, stability of adjacent earth or man-made masses, potential and existing damage to existing structures and facilities, and other pertinent observations.

14.2.3 Foundation Soil Borings

14.2.3.1 Locations of Borings

Minimum number and spacing of borings for bridge and retaining wall foundations shall be in accordance with spacing limits specified in TxDOT *Geotechnical Manual*. Additional guidance regarding boring spacing is provided in AASHTO LRFD BDS. To complete substructure design additional borings will be necessary to identify unique site conditions or as follow-up to unusual items identified during site exploration or laboratory testing. Where possible, borings for bridge foundations shall be located adjacent to proposed piers and abutments.

14.2.3.2 Depths of Borings

Borings shall extend to depths sufficient to define subsurface profile for structures, embankments, and geotechnical features. All bridge borings in soil shall be carried to a depth of not less than 20 feet below proposed bridge foundation element elevation, as defined by TxDOT *Geotechnical Manual*. Borings drilled at retaining walls shall be drilled to depths specified in the TxDOT Geotechnical Manual. Borings for other project elements shall be drilled and sampled in accordance with relevant AASHTO, FHWA, and TxDOT procedures.

14.2.3.3 Drilling Methods

Either rotary drill method, hollow-stem auger method, or other acceptable means (in accordance with TxDOT guidelines) shall be used to advancing boring and recovering undisturbed samples. Prior to drilling for the Project, each drill rig shall be inspected by a Registered Professional Engineer and certified that hammer weight and drop height meet TEX 132-E Texas Cone Penetration Test or ASTM D1586 requirements.

Rotary Drill. Rotary drill method shall be conducted as described in Section 7.5.1.4 in AASHTO *Manual on Subsurface Investigations*. Use of casings shall be at the DB Contractor's discretion, except that casing shoe or bit shall not extend below top of any interval to be sampled. All casings shall be removed upon completion of boring.

Hollow-Stem Auger. Hollow-stem auger method shall be conducted as described in Section 7.5.1.5 in AASHTO *Manual on Subsurface Investigations*.

14.2.4 Standard Penetration Tests

Testing Standards. Standard penetration test (SPT) and split-barrel sampling of soils shall proceed in accordance with ASTM D1586. Texas Cone Penetration (TCP) Testing will be allowed but is not mandatory. If TCP testing is not provided, foundation design shall follow applicable FHWA and AASHTO procedures using LRFD soil strength-based design methods.

14.2.5 Texas Cone Penetration Test

Testing Standards. Texas Cone Penetration (TCP) test, if used, shall proceed in accordance with TEX 132-E Texas Cone Penetration Test.

14.2.6 Soil Sampling

Sampling Standards. Thin-walled tube sampling of soils shall comply with ASTM D1587 or ASTM D1586. Thick-wall tube sampling may be necessary in stiff clays. Other sampling methods shall be performed in accordance with applicable ASTM procedures.

14.2.7 Rock Core Drilling

Drilling Standards. A minimum of NQ2 core diameter shall be obtained. Diamond core drilling in rock shall be in accordance with ASTM D2113.

14.2.8 Borehole Sealing and Cleanup

Records. The DB Contractor shall submit records of borehole sealing upon completion to the Mobility Authority.

Drill Hole Filling. Fill or plug all drill holes to prevent injury to livestock or people in the area and to minimize the entry of surface water into the bore hole. Patch pavements with cold mix asphalt or concrete (match existing pavement surface of affected road or drive). All borings must be plugged with a non-shrink grout from the bottom of the hole (top of the bentonite plug in the case of groundwater presence) utilizing tremie pipe or equivalent to within three (3) feet of the surface. The remainder of the hole must be backfilled with cuttings from the boring or gravel. If groundwater is encountered during geotechnical boring activities, backfill the borehole with clean washed 1 inch rock to approximately 2 feet above the groundwater level, placing a hole plug above the rock surface, capping the hole plug with a packed bentonite plug, and then sealing the top of the boring as per normal protocol. All borings must be backfilled or plugged within four (4) days of completion of the drilling operations.

Cleanup. Upon completion of field Work, the DB Contractor shall remove all surplus material, temporary structures, debris on land and water, and leave premises in a neat, orderly condition. If any improvements are disturbed during boring operations, the DB Contractor shall restore in kind and character to condition existing prior to commencement of Work.

14.2.9 Field Boring Logs

The DB Contractor shall record all pertinent information, using a field boring log for each boring. Logs shall be prepared in ink or by electronic media with printed copies filed daily. The DB Contractor shall submit a copy of each original field log to the Mobility Authority. Field logs shall be submitted on a weekly basis during drilling activities.

Page Identification. Each page of each boring log shall be identified with:

- Boring Number or ID.
- Sheet Number.
- Total number of sheets in the log.

Log Contents. Each boring log shall contain, at a minimum, the following information:

General Identification:

- Project identification number.
- Bridge designation or other identifying feature.
- Dates of start and completion of boring.
- Name of drilling company, drill operator, and borehole logger.
- Description of drill rig, TCP or SPT hammer weight and drop, and hammer drop method.

Boring Location:

- Location of boring (with centerline station and offset, measured to nearest foot).
- A vertical reference, indicating a preliminary ground surface elevation of boring to nearest 0.5 feet with final surveyed elevation being reported on final boring log.

Results:

- Field number of each sample, type of sample, and sample depth.
- Groundwater measurement data (as practicable, dependent on drilling method employed). Groundwater levels shall be obtained during drilling, at completion of drilling, and 24 hours after completion of drilling.
- Description of each soil stratum encountered and sample obtained; including color, strength, moisture content, composition, and estimated consistency.

Drilling Parameters:

- Diameter of boring.

- Method of drilling and sampling employed.
- Depth at changes in rate of advance of bit.
- Depth(s) at which any obstacle was encountered in advancing boring.
- Depth at which drilling mud return circulation was lost.
- Driven casing depth.
- For TCP or SPT, number of blows (in 6-inch increments) required to drive sampler.
- For a rock core, length of each run, length of core recovered, and Rock Quality Designation (RQD).
- For plug drilling, type of cuttings flushed to surface.
- If specified depth was not reached, reason for abandoning boring.
- Depth and dimensions of all voids encountered over 0.5 feet in diameter.
- Any water loss observed during drilling, denote in percentages of loss.
- Any other unusual conditions encountered during drilling and sampling.

Definitions: Definition of all symbols that are not self-explanatory

Borehole Survey Information. The DB Contractor shall provide survey information, for each borehole, as follows:

- Horizontal and vertical tie-ins to permanent Project survey control (survey coordinates).
- Mean sea level (MSL) reference elevations taken from known benchmarks accurate to ± 0.1 foot.
- Station and offset information for current alignment designators.

14.3 Laboratory Soil Tests

The DB Contractor shall perform laboratory soils tests of sufficient number and type to ascertain nature, total and effective strength properties, in situ moisture and density conditions, stability, and consolidation characteristics of soil conditions existing at site that are pertinent to design and construction activities.

14.3.1 Soil Classification

Every sample shall be visually inspected, manipulated by hand, and fully described, with consideration given to logger's description of material on field boring log and particular emphasis to soil layer changes.

Mineral Soils. Using TxDOT *Geotechnical Manual*, all mineral soils shall be classified. Each layer and sample shall be described by color, moisture content, relative density, and relative consistency. All symbols and descriptions shall be defined on final boring logs.

Organic Soils. Organic soil samples shall be described by percentage (by weight) of organic matter (as determined by AASHTO T267, or similar approved method).

14.3.2 Laboratory Tests

Soil Moisture Content Tests. Laboratory determination of moisture content of soil shall proceed in accordance with AASHTO T265 or equivalent. Moisture content shall be determined for every soil sample except wash samples and tailings.

Unconfined Compression Soil Tests. Testing for unconfined compressive strength of cohesive soil shall proceed in accordance with AASHTO T208.

Load Value. Unconfined compressive strength shall be determined from maximum load value obtained or load at 15% strain, whichever is secured first.

Minimum Testing. A minimum of one unconfined compression test per boring shall be conducted on thin-walled (or thick-walled) push-tube sample of cohesive soil, if applicable.

Triaxial Compression Tests. Testing for strength parameters of soils by triaxial compression shall be in accordance with AASHTO T297 with pore water pressure measurement. Three different consolidation pressures shall be used to define a failure envelope.

Unit Weight Tests. Moist unit weight shall be determined in conjunction with unconfined compression and triaxial compression tests.

One-Dimensional Consolidation Tests. Testing for one-dimensional consolidation properties of soils shall proceed in accordance with AASHTO T216. Samples shall be chosen to represent major compressible soil strata on overall Project.

Specific Gravity Determination. Testing for specific gravity of soils shall proceed in accordance with AASHTO T100. Specific gravity of soils shall be determined in conjunction with consolidation tests.

Atterberg Limit Tests. Testing for liquid limit of soils shall proceed in accordance with AASHTO T89. Samples shall represent major soil strata on overall Project. Testing for plastic limit and plasticity index of soils shall proceed in accordance with AASHTO T090. Plastic limit and plasticity index shall be determined for all samples that are tested for liquid limit. All samples tested in consolidation and in tri-axial compression shall be tested for Atterberg limits.

Grain Size Analysis. Particle-size analysis of soils shall proceed in accordance with AASHTO T088. Particle-size analysis shall be determined for all samples that are tested for liquid limit.

Organic Content Tests. Testing for organic matter content of soils shall proceed in accordance with AASHTO T267. Samples for organic matter testing shall be selected to represent major soil strata on overall Project that are black in color or described as organic.

Unconfined Compression Test – Rock. Testing for unconfined compressive strength of rock shall proceed in accordance with ASTM D7012.

14.3.3 Final Boring Log

A final boring log based on field boring log and containing all laboratory test results shall be prepared for each test boring.

Title Page. Title page for each final boring log shall contain:

- Sheet number and total number of log sheets for each boring.
- Boring number.
- Project number.
- Bridge number or other identifying feature.
- Dates of drilling.
- Centerline station.
- Offset distance.
- Surface elevation.
- Texas State Plane Coordinates.
- Type of drilling equipment.
- TCP hammer type (auto).
- Whether drilling mud was used.
- Definition of all symbols and terms not otherwise self-explanatory.

Body of Log. Finished boring log body shall contain:

- Depth scale.
- Horizontal line at stratum change.
- Elevation of bottom of boring.
- All logger's notes, tabulated by zone in which conditions were encountered.

- All laboratory test results, tabulated by retrieval depth.
- A description of material of each stratum.
- Water level observation.

14.4 Geotechnical Analysis and Design

14.4.1 Geotechnical Reports

General. The DB Contractor shall produce Geotechnical Engineering Reports, signed and sealed by a Registered Professional Engineer, for each structure or geotechnical feature on the Project. Report recommendations shall include engineering analyses and design recommendations, and shall be concise, specific, easily interpreted, and referenced to applicable industry standards. The report should include multiple wall designs for each wall when subsurface conditions vary within the limits of the wall and to capture the most critical conditions for global stability, bearing pressure, sliding, overturning, and eccentricity.

Deliverables. The following geotechnical engineering reports shall be submitted:

- A **Bridge Geotechnical Report** shall be prepared for each bridge submittal. Multiple structures crossing the same site feature, such as general purpose lane (left and right) and adjacent general purpose lane bridges, shall be considered one bridge for reporting purposes. Each Bridge Geotechnical Report shall contain all necessary backup to review the report including but not limited to; plan of borings, boring logs, test data, and design parameters used.
- A **Retaining Wall Geotechnical Report** shall be prepared for each retaining wall package submittal. Adjacent or connecting walls, such as wrap-around walls at bridge abutments, shall be considered one wall for reporting purposes. Each Retaining Wall Geotechnical Report shall contain all necessary backup to review the report including but not limited to; plan of borings, boring logs, test data, and design parameters used.
- Early Release submittals shall include summary **Design Memoranda** that address the geotechnical aspects of the submittal. Complete recommendations are to be incorporated into the Geotechnical Design Report. Each Design Memoranda shall contain all necessary backup to review the report including but not limited to; plan of borings, boring logs, test data, and design parameters used.
- A **Geotechnical Design Report** shall be submitted to accompany each complete roadway submittal. If multiple design segments are used, a separate Geotechnical Design Report shall be submitted for each segment. The Geotechnical Design Report shall address all non-bridge or non-retaining wall foundation features along the segment, including slopes, embankments, noise walls, sign foundations, and other site-features as appropriate. Each Geotechnical Design

Report shall contain all necessary backup to review the report including but not limited to; plan of borings, boring logs, test data, and design parameters used.

Design Standards. All geotechnical designs, calculations, and recommendations shall be reviewed, checked, dated, and initialed by a Registered Professional Engineer. Analysis work and calculations shall be in accordance with recognized methods and engineering practice and conform to requirements of TxDOT *Geotechnical Manual*, TxDOT *LRFD Bridge Design Manual*, and *AASHTO LRFD Bridge Design Specifications*. Foundation loads for bridges shall be determined using AASHTO LRFD Bridge Load Combination Service I for the Service Limit State and the controlling Strength load case for the Strength Limit State. AASHTO Bridge Design Specifications shall be followed to evaluate bridge foundations at the Strength Limit State. AASHTO or TxDOT methods may be used to evaluate bridge foundations for the Service Limit State.

Methods and procedures for stability analysis, settlement, bearing capacity, and foundation requirements shall follow applicable industry standards. All assumptions, soil parameters, water levels, and design criteria shall be stated and design cross sections shall be provided in the calculations. Method of analysis and procedures shall be referenced to engineering design manual, texts, handbooks, and journals, including page references.

Design settlement and deflection for sound, retaining, and neighborhood walls and barriers shall not exceed the values listed in *Table 3-8, Technical Provisions 3.4.7*. When computer programs are used, output forms may be submitted in lieu of design computations; however, output must be clearly referenced and supported as necessary by narrative and hand calculations. Where computer output is provided, the design input must be verified as part of the checking process. Global stability analysis of multiple critical failure surfaces shall be computed using both circular and non-circular methods that accurately reflect site conditions where applicable and/or upon request of the Mobility Authority. A check calculation initialed by a Registered Professional Engineer shall be performed on the most critical slip circle when computer analysis is used for slope or retaining wall analysis.

Submittal of Reports. Submittal and review of Geotechnical Engineering Reports shall be in conjunction with associated structural or roadway plan submittals. Draft reports shall accompany the Intermediate (65%) Design Submittals and final reports with Final (100%) Design Submittals. Copies of all geotechnical design calculations shall be included with the draft and final report submittals. The DB Contractor shall address review comments and prepare final reports. Final signed and sealed reports shall be submitted to the Mobility Authority concurrent with associated RFC plan submittals.

Contents. Geotechnical Engineering Report shall contain the following sections:

- Project Information
- Subsurface Investigation Summary, including:
 - Subsurface Investigation and laboratory test results

- Design Assumptions
- Foundation Analysis
- Foundation Recommendations
- Construction considerations

14.4.1.1 *Project Information Section*

This section shall identify structure analyzed by type and location, and give any other pertinent information that aids in general description of design.

14.4.1.2 *Subsurface Investigation Summary Section*

This section shall contain information about borings, briefly describe foundation soil and rock conditions at site, summarize water table measurements, denote voids encountered, water loss in each boring, and interpret static water level, if applicable. Figures and appendices shall include the boring location plans, final boring logs, and laboratory test results. Each report shall present related supporting data, including previous boring logs and lab results, and as-built plans, if referenced in the report. Supporting data shall be presented in separate appendices from information developed by the DB Contractor.

14.4.1.3 *Design Assumptions Section*

This section shall summarize design assumptions, including:

- Embankment fill heights, and assumed or minimum soil properties for embankment fill.
- Unit weights of fill.
- Side-slope and end-slope angles.
- Bridge loading information (axial, shear, and moments).
- Retaining wall loading information and required backfill and retained fill properties.
- Design methodologies.
- Any other pertinent information.

14.4.1.4 *Foundation Analysis Section*

The DB Contractor shall summarize results of detailed geotechnical analysis, identifying critical design elements and provide basis for geotechnical recommendations.

Bridge Structures. For bridge structures, suitable foundation types shall be assessed and alternate foundation types reviewed. For foundations of widened structures, design with the same type of foundation element as the existing structure. If the existing bridge foundation is a shallow footing,

the bridge shall be widened with a deep foundation element such as a drilled shaft or other acceptable method.

Embankments. For embankments, overall stability shall be assessed including bearing capacity, settlement, and global stability. The DB Contractor shall provide settlement analysis in conjunction with use of wick drains, surcharged embankments, and lightweight fill material, where required. In addition, an estimate of time rate of settlement shall be included to account for primary and secondary settlement that may be expected over life of facility.

Retaining Walls. Retaining wall designs shall meet the requirements of this Technical Provision 14 and Technical Provision 12. The report shall include results of external stability analysis of retaining walls, which shall include direct sliding, limiting eccentricity (overturning), bearing, settlement, and global (rotational) stability. All retaining walls shall use a resistance factor of 0.65 (factor of safety of 1.5) for global stability. Global stability analyses shall include non-circular optimized surfaces in clay soils, and shall consider both effective and total stress soil parameters. The report shall specify the required soil properties and strengths for the retained embankment fill behind the wall.

Bearing capacity and settlement analysis shall be provided. Analysis shall include an estimate of total and differential settlement anticipated for each structure. Differential settlements for retaining walls shall be calculated based on 30-foot spacing. Estimate of time rate of settlement shall be included to account for primary and secondary settlement over life of facility.

Drilled Shafts. For drilled shafts, capacity figures shall show capacity in relation to tip elevation for both compression and tension for both strength and service cases where applicable. The geotechnical engineer shall work with structural engineer to identify the information required for each structure as a function of the structure type and loading. In lieu of capacity plots, the geotechnical engineer may present the foundation design recommendations in tabular form to address the controlling service and strength cases. Down drag, uplift, and lateral squeeze shall be incorporated into the design where applicable. The geotechnical engineer shall provide design parameters for L-Pile, as required, to evaluate shear and bending in the foundation elements. Minimum tip elevations, minimum penetration into bearing stratum, casing requirements and estimates of overdrive shall be provided.

Scour. All foundation elements shall be designed to account for losses in lateral and vertical support due to scour from the design flood event. The scour analysis shall follow the TxDOT *Geotechnical Manual* and the latest version of HEC-18.

Other Information. When required, foundation analysis shall include:

- Analyses for structures supported on rock or tied to rock formations, including areas such as rock bolts and rock cuts.

- Construction considerations, such as design of temporary slopes and shoring limits.
- Suitability of temporary construction methods, such as soil nails or tiebacks.
- Special requirements for elements that may encounter difficult ground conditions or that may require atypical construction methods.
- Over-excavation (subcut) recommendations, backfill requirements, and related details.
- Construction staging requirements.
- Evaluation of wet-weather construction and water control during temporary construction.

14.4.1.5 Foundation Recommendations Section

This section shall present recommendations, as applicable, such as:

- Bearing capacities and associated resistance factors.
- Footings for drilled shafts and retaining walls shall include the sizes and embedment depths.
- Drilled shaft dimensions, minimum penetration into bearing stratum, estimated tip elevation, and construction methods.
- Slope angles.
- Settlement waiting periods for embankments and retaining walls.
- Surcharge recommendations.
- Foundation types, sizes, and embedment depths.
- Topsoil excavations and muck and poor soil excavations.
- Trench excavation slopes.
- Temporary slopes and shoring limits.

14.5 Geotechnical Field Instrumentation

The DB Contractor shall produce a Geotechnical Instrumentation Plan and submit it to the Mobility Authority as a part of the Formal Design Review prior to commencing earthwork.

Contents. The DB Contractor shall identify recommended instrument types, locations, installation requirements, zones of influence, critical readings, and frequency of readings in Instrumentation Plan. Instrument readings shall be included in supplemental instrumentation monitoring reports, as readings become available, including monitoring done during and after construction. All instruments shall be installed and monitored by the DB Contractor. Any instruments that are damaged during construction and require removal and/or recalibration shall be replaced and/or recalibrated at the DB Contractor's expense.

Monitoring. The DB Contractor shall install geotechnical instrumentation where necessary to monitor:

- Vibrations.
- Settlement and settlement rates of embankments.
- Pore water pressures.
- Ground water levels.
- Stability of walls and slopes.

14.6 Settlement Damage to Adjacent Properties

Zones of Influence. The DB Contractor shall monitor settlements of structures, utilities, and other features within zone of influence of constructed embankments and retaining walls. For embankments, the zone of influence shall be defined as a zone extending a minimum horizontal distance (H) from toe of embankment, where H is height of embankment. For retaining walls, zone of influence shall extend from toe of footing to a minimum distance of twice height of wall.

Responsibility for Damage. The DB Contractor is responsible for all damage caused by settlements to adjacent properties.

14.7 Vibration Monitoring and Control

DB Contractor Responsibility. Construction activities may produce vibrations (such as pile-driving, vibratory compaction, pavement-breaking, or operation of heavy construction equipment). Various structures are located close to proposed Work. All construction activities must be conducted to preclude damage to adjacent structures and limit impacts to occupants.

Monitoring Plan. Where construction activities are proposed that produce vibrations that could impact adjacent structures, the DB Contractor shall establish a vibration monitoring plan and submit it to the Mobility Authority for review and comment as a part of the Formal Design Review. Such plan shall include details for monitoring during vibration-producing activities (including, but not limited, to all and pile-driving). The vibration monitoring plan shall delineate areas where vibration-producing construction activities will take place and propose monitoring locations. The plan shall be appropriate to the site-specific features of the project.

Damage. The DB Contractor shall be responsible for all damage caused by construction activities, including activities of any Subcontractor.

General Requirements. Before beginning any vibration-producing construction activities, the DB Contractor shall:

- Contact nearby residents and others who may be affected.

- Conduct preconstruction survey identifying structures susceptible to vibration damage.
- Establish vibration control threshold limits that will preclude damage (cosmetic cracking) to adjacent structures and interference with sensitive equipment.
- Monitor and document vibrations during vibration-producing activities.

14.7.1 Notification

The DB Contractor is required to contact each household, institutional operator, and business establishment within construction area and near enough to easily perceive ground vibrations. Contact shall be by letter, sent before commencing pile-driving, or other construction activity that produces easily perceptible ground vibration. Letter shall be submitted to the Mobility Authority for review. Letter shall include, at a minimum:

- Describe proposed construction.
- Explain potential for producing vibrations.
- Specify steps that will be taken to avoid potential damage from vibrations.
- Name and telephone number of contact person to respond to questions or concerns.
- Before beginning related construction operations, the DB Contractor shall submit to the Mobility Authority a list of these contacts, including:
 - Name and address of person(s) contacted and (if known) their telephone numbers.
 - Date letter was sent.
 - Location(s) and telephone numbers of the building(s).

14.7.2 Preconstruction Survey

The DB Contractor shall have expertise in areas of vibration mitigation and building damage susceptibility, or employ a Sub-consultant with such expertise. The DB Contractor shall review proposed construction plans and identify areas where construction activities such as pile-driving will be close to existing building and structures.

The DB Contractor shall conduct a Preconstruction Survey in two parts:

- Preconstruction Susceptibility Study
- Preconstruction Building Condition Study

14.7.2.1 Susceptibility Study

Scope of Survey. Before beginning any construction activity on site, the DB Contractor shall perform a Preconstruction Susceptibility Study of all buildings within:

- 250 feet from future pile-driving activities.
- Distance at which vibrations of 0.1 inch per second or greater will occur from construction activities.

Objective of Survey. Objective of survey is to assess each building in survey area and determine susceptibility to disruption by vibration-producing construction activities. Disruption includes both cosmetic cracking (threshold damage) and impacts on sensitive equipment operation. The DB Contractor shall categorize susceptibility of each building to cracking during construction activities as high, moderate, or low.

Right-of-Entry. The DB Contractor shall be responsible for obtaining any and all Right-of-Entry releases from property owners needed to conduct precondition surveys.

Cosmetic Cracking. Susceptibility to cracking, which is:

- Threshold damage (e.g., opening of old cracks and formation of new plaster cracks; dislodging of loose structural particles such as loose bricks from chimneys).
- Architectural or minor damage that is superficial and does not affect strength of structure (e.g., broken windows; loosened or fallen plaster; hairline cracks in masonry).

Building Susceptibility. Categories of building susceptibility to vibration are:

High Susceptibility. A building that has already experienced a significant amount of degradation of its primary structural and/or nonstructural system. Additional vibrations may further degrade these elements and possibly result in injuries to persons in building. Buildings with loose or unstable elements, (such as loose bricks or structurally cracked terra-cotta cornices) are in this category.

Moderate Susceptibility. A building that may have experienced some building deterioration prior to construction activities although it has not yet experienced significant degradation of its primary structure or its nonstructural systems that would lead to further building degradation due to construction vibrations. This category includes buildings with bricks that may be loose (as determined by visual inspection) and buildings with small to moderate quantities of fragile, potentially unstable contents that may be damaged by construction vibrations.

Low Susceptibility. A building that is not expected to experience cosmetic cracking when subjected to moderate vibrations (such as those permitted by OSM vibration criteria) and if its contents will not be damaged by moderate vibrations.

14.7.2.2 Sensitive Operations and Equipment

Vibration Sensitivity. As part of Susceptibility Study, the DB Contractor shall determine whether there are sensitive operations and/or equipment nearby, such as hospitals, computerized industries or banks, and industrial machinery. The DB Contractor shall include a list of buildings with sensitive equipment or procedures in Susceptibility Report. The DB Contractor shall take this information into account when specifying vibration control limits.

Susceptibility Report. Survey shall summarize in a susceptibility report each building and its susceptibility to vibration.

14.7.2.3 Building Condition Survey

Survey Items. Each building shall have its existing structural and cosmetic condition documented, including, but not limited to, the following items:

- All interior subgrade and above-grade walls.
- Floors.
- Ceilings.
- Roof.
- Visible exterior as viewed from grade level.

At a minimum, conditions shall be documented with photographs or engineering sketches of each wall, ceiling, floor, and roof, with each identified by its relative location within building.

Building Condition Report. Survey shall be summarized in a Building Condition Report, which will include location of each building, documentation of existing conditions, and a description of areas of concern; in a format acceptable to the Mobility Authority.

14.7.2.4 Preconstruction Survey Submittal

Before beginning construction involving pile driving, the DB Contractor shall submit Preconstruction Survey Report, comprising:

Contacts: List of building locations, building occupants, institutional owners, and businesses with whom the DB Contractor has contacted and notified of potential for construction-induced vibrations.

Preconstruction Susceptibility Study: List of buildings and susceptibility to vibration damage, including any buildings with sensitive equipment or procedures that may require special care or adjustments to normal construction procedures.

Preconstruction Building Condition Report: List of buildings and condition of each structure prior to any construction activity.

14.7.3 Vibration Controls

Based on identified buildings with sensitive equipment or procedures listed in Preconstruction Survey, the DB Contractor shall establish vibration control limits at a level that precludes threshold damage (cosmetic cracking) to adjacent structures and interference with sensitive equipment. This vibration limit shall be site- and activity-specific, but may not be less restrictive (i.e., it may not allow higher vibration levels) than OSM frequency-based vibration criteria (C.H. Dowding, *Construction Vibrations*, 1996). Vibration limits shall be summarized in a report to the Mobility Authority, and shall specify special requirements. Vibration limits shall be expressed in *peak particle velocity*, which is maximum rate of change of particle displacement with respect to time.

14.7.4 Monitoring of Vibrations

At a minimum, the DB Contractor shall monitor vibrations at all buildings within 100 feet of pile-driving activities. If more than one structure lies within minimum distance, the DB Contractor shall monitor two closest or most critical buildings. The DB Contractor shall monitor vibrations continuously during vibration-producing events. If vibration level of any of the three components of peak particle velocity exceeds vibration limit, then the DB Contractor must immediately cease vibration-producing activity and notify the Mobility Authority that a violation has occurred. The DB Contractor shall submit a written report to the Mobility Authority explaining conditions of violation and steps to be taken to reduce vibrations below vibration limit. The DB Contractor may not resume vibration-producing activity until given written permission to do so by the Mobility Authority.

14.7.4.1 Instrumentation

Vibration instrumentation must be able to measure, record, and produce a hard copy printout of frequency and peak particle velocity in three mutually perpendicular axes. Vector sum instrumentation is not allowed. Instrument must also be able to plot measured vibration level against OSM criteria, or report frequency and displacement of each vibration event.

Number of instruments required depends on specific site, and shall be addressed in Vibration Monitoring Plan. There shall be a minimum of two vibration monitors. One monitor shall be used on-site. The second monitor shall be used as needed, at a critical structure or at a specific complaint location.

14.7.4.2 Data Recording

The DB Contractor shall maintain records of all vibration-producing activities for which vibration monitoring is required. Monitoring records shall be made available to the Mobility Authority. Records shall include:

- Location of vibration-producing event.
- Distance from event to monitoring site(s) Maximum peak particle velocity.

Scaled distance:

- For pile-driving, actual distance divided by square root of pile-driving energy.

14.7.4.3 Vibration Monitoring Submittals

Before beginning any construction activity involving pile-driving, the DB Contractor shall submit to the Mobility Authority the following vibration monitoring documents:

- Vibration Control Limits.
- Vibration Monitoring Plan, including:
 - Type(s) of vibration instrumentation that the DB Contractor will supply.
 - Current calibration records for each instrument.
 - Designated person who will be in charge of deploying and operating instruments.

14.8 Submittals

Table 14-1: Submittals to Mobility Authority

Submittals	Submittal Schedule	Mobility Authority Action	Reference Section
Surface Investigation Plan	Before commencing Work	Information	14.2.1
Field Boring Logs	Weekly	Information	14.2.9
Preliminary Geotechnical Engineering Reports	With the Intermediate (65%) Design Submittals	Review and Comment	14.4.1
Final Geotechnical Engineering Report	With the Final (100%) Design Submittals	Approval	14.4.1
Geotechnical Instrumentation Plan	Part of the Formal Design Review	Information	14.5
Vibration Monitoring Plan	If needed, as part of the Formal Design Review	Review and Comment	14.7
Ground Vibration Notification Letters	Before commencing construction activity that produces easily perceptible ground vibration	Review	14.7.1
Preconstruction Survey Report	Before beginning construction involving pile driving	Information	14.7.2.4

15.0 DRAINAGE DESIGN

The DB Contractor shall be responsible for providing drainage for the Project in accordance with the requirements identified in this Technical Provision 15 and Exhibit C - Attachment 15-1 Impact Assessment Evaluation Requirements.

The drainage features including inlet, pipe, water quality and detention pond locations shown in the Schematic Plan and the preliminary drainage report are preliminary in nature and shall not be assumed to be representative of the final design location and configurations.

The DB Contractor's Project Design shall include all components of the drainage and stormwater management systems including all curb inlets, grate inlets, manholes, junction boxes, headwalls, safety end treatments, culverts, storm sewers, lined channels, ditches, swales, detention ponds and water quality facilities, bridges and any other appurtenances necessary to provide proper drainage and water quality treatment for the Project. The DB Contractor shall design and construct a drainage system that provides a well-drained corridor, a safe environment for the individuals who construct, use, and maintain the corridor, ensures no adverse impacts, promotes best management practices through enhanced ecological performance and reduces long term operations and maintenance costs of the system.

15.1 Standards and Guidelines

In addition to the requirements provided in this Technical Provision 15, the DB Contractor shall comply with the following as applicable:

- *TxDOT Hydraulic Design Manual*
- *TxDOT Roadway Design Manual*
- *TxDOT Bridge Project Development Manual*
- *TxDOT Geotechnical Manual*
- *TxDOT Standard Specifications for Construction and Maintenance of Highways, Streets, and Bridges*
- *TxDOT Memo on Updated Rainfall Data*
- *TxDOT Memo on Developer's Outfall Into a TxDOT Drainage Facility Policy*
- U.S. Department of Agriculture Soil Conservation Service (NRCS), *Hydrology Design Manuals*
- FHWA, Hydraulic Engineering Circular 14 (HEC 14) – *Hydraulic Design of Energy Dissipators for Culverts and Channels*
- FHWA, Hydraulic Engineering Circular 18 (HEC 18) – *Evaluating Scour at Bridges*
- FHWA, Hydraulic Engineering Circular 20 (HEC 20) – *Stream Stability at Highway Structures*

- FHWA, Hydraulic Engineering Circular 21 (HEC 21) – *Design of Bridge Deck Drainage*
- FHWA, Hydraulic Engineering Circular 22 (HEC 22) – *Urban Drainage Design Manual*
- FHWA, Hydraulic Engineering Circular 23 (HEC 23), *Bridge Scour and Stream Instability Countermeasures*
- FDOT, *Design Guidance: Hydroplaning Risk Analysis*
- TCEQ, *Technical Guidance on Best Management Practices RG-348, including Errata Sheet (March 28, 2009) and Addendum Sheet*
- TCEQ, *Technical Guidance on Best Management Practices RG-348 Appendix A*
- TCEQ, *Technical Guidance on Best Management Practices RG-348 Appendix B*

Disclaimer. The Mobility Authority makes no warranties as to the accuracy or usefulness of the above information, and the DB Contractor assumes all risks associated with its use.

15.2 Drainage Analysis and Evaluation

The DB Contractor shall design the drainage and stormwater management systems, and obtain all required permits. At a minimum, all design Work shall comply with the TxDOT *Hydraulic Design Manual*.

The DB Contractor is responsible for coordinating with all applicable permitting agencies. Full documentation of all meetings and decisions is to be submitted to the Mobility Authority, and these activities and submittals must be coordinated through the Mobility Authority.

30% Drainage Report(s). The DB Contractor shall provide the Mobility Authority for review and acceptance an interim sealed 30% Drainage Report which will accompany the Preliminary (30%) Design Submittal. The report shall include drainage area maps, hydrology and hydraulic calculations, and location of proposed/adjusted drainage facilities such as inlets, pipes, detention ponds, culvert adjustments, and water quality facilities, as well as applicable electronic models and files. The focus of the Preliminary Drainage Report shall be on hydrologic impacts, detention sizing, hydraulic sizing and impacts at cross structures and outfall channels, and water quality treatment locations. Preliminary drainage data developed by others should be reviewed and evaluated by the DB Contractor and updated based on the best available data. The 30% Drainage Report will be a stand-alone report, not restating conclusions from or referencing previous reports.

65% Drainage Report(s). The DB Contractor shall provide the Mobility Authority for review and acceptance an interim sealed 65% Drainage Report, which will accompany the Intermediate (65%) Design Submittal. The report shall include drainage area maps, hydrology and hydraulic calculations, flow velocities and proposed measures to minimize and mitigate high velocity and concentrated flows, and location of proposed/adjusted drainage facilities such as inlets, pipes, detention ponds, culvert adjustments, and water quality facilities, as well as applicable electronic models and files. The 65% Drainage Report

shall refine on the 30% Drainage Report and be significantly complete including assessment of waterway stability, erosion potential, sheet flow impacts, risk assessment and mitigation measures.

100% Drainage Report(s). The DB Contractor shall provide the Mobility Authority for review and acceptance a signed and sealed Final Drainage Report, which shall be a record set of all drainage computations, and shall accompany the Final (100%) Design Submittal. The report shall include drainage area maps, hydrology and hydraulic calculations, and location of proposed/adjusted drainage facilities such as inlets, pipes, detention ponds, culvert adjustments, and water quality facilities, as well as applicable electronic models and files. The DB Contractor shall include all support data, such as soil boring logs, calculations, and supporting graphical CAD files, models or any additional data requested by the Mobility Authority.

Addendum(s) to the Drainage Report(s). After substantial completion of construction any changes that would impact the results found in the 100% Drainage Report will be included in an addendum to the Drainage Report. This addendum will clearly state what changes were made and include all support data.

15.2.1 Data Collection for Drainage Design

General. The analysis and design of the drainage components for the project design will require acquisition and evaluation of appropriate data in the subject watersheds and general vicinity of the Project, including:

- Watershed characteristics.
- Stream data.
- Climatological data.
- Other physical data such as, but not limited to, general gradients, topographic features, and vegetation cover.

Data & Studies. Data pertinent to these watercourses and associated watersheds may be obtained from previous studies, if applicable, or may require supplementary investigations. The DB Contractor shall generate and examine such data required for the analysis and design of the drainage components. In all cases, the DB Contractor shall conduct field reconnaissance to verify the existing data and/or to obtain supplementary information.

The components of the drainage and stormwater management systems including all inlet, pipe, water quality and detention pond locations are shown on the Schematic Plan in Exhibit D – Item 3 – Technical (Roadway). A schematic drainage report is provided in Exhibit D – Item 3 – Technical (Drainage). The report is preliminary in nature and shall not be assumed to represent final design location and configurations. The purpose of the schematic drainage report was to define constraints and develop criteria for the drainage and water quality design. All drainage and water quality components need to be reviewed, analyzed, and designed by the DB Contractor. Additionally, preliminary pond locations shown in the schematic drainage and water quality components shown within the schematic reports and plans may not align. .

Physical Features. Watershed characteristics should include drainage area size, general topography, land use for existing and fully developed offsite conditions, soil types, proposed landscape planting and existing vegetation to remain, and other pertinent physical features. Stream data should include geomorphic factors as outlined in FHWA’s *Hydraulic Engineering Circular No. 20 – Stream Stability at Highway Structures*, including roughness characteristics, stream profile and cross sections, historic flood stages, upstream and downstream flow controls including existing and proposed structures, and soil borings from the channel and floodplain in the vicinity of the proposed improvement. The DB Contractor shall obtain historic scour data from bridge inspection records for existing bridges and other crossings on the same and nearby watercourses. If applicable, the DB Contractor shall obtain stream flow data from USGS or other Governmental Entities gauging stations for watercourses to be crossed. The DB Contractor shall include documentation of the obtained data, including field site survey photographs as part of the overall drainage design/analysis submittals to the Mobility Authority.

15.2.2 Hydrology Analyses and Design

General. The DB Contractor shall perform hydrologic analyses for the design of drainage features for the fully developed offsite conditions. The hydrologic and water quality analysis and sizing do not need to include the Ultimate Design, future direct connector ramps and RM 620. The onsite storm drain design and water quality BMP design shall accommodate the Ultimate Design improvements, without need for removal. Water quality BMPs shall accommodate the future foundations for the direct connectors. The DB Contractor shall select the appropriate hydrologic method based on the criteria in this *Technical Provision 15*. Models and methods available from adjacent jurisdictions may be considered as appropriate best available data following coordination with Mobility Authority. All models must be updated to the latest version of relevant software and be georeferenced. The type and extent of the analyses should be commensurate with the hazards associated with failure of the proposed drainage feature and with other concerns including economic, engineering, social, and environmental factors. The DB Contractor shall use unit hydrograph methods for all detention and routing analysis. The use of climactic adjustment factors is prohibited on this Project.

Frequency Selection. The DB Contractor shall design the drainage component capacities by frequency selection for the fully developed offsite conditions as indicated in this *Technical Provision 15*. When rainfall-runoff analyses are conducted, the DB Contractor shall include determination of design rainfall distributions and abstractions. The DB Contractor may assume that rainfall amounts will be uniformly distributed within individual drainage areas. Abstractions used by the DB Contractor for the analysis must include infiltration.

Precipitation Data The DB Contractor shall obtain climatological data, specifically rainfall and/or intensity-duration–frequency data for analysis of hydrology and contributing drainage areas. Atlas 14 rainfall data shall be used for all project requirements and can be obtained from the National Oceanic and Atmospheric (NOAA) National Weather Service Atlas 14 Point Precipitation Frequency Estimation website. The approximate middle of the Project at US 183 and Spicewood Springs Rd./McNeil Dr. (Lat.

30.4333°, Long. -97.7692°) shall be used as the point of analysis to determine precipitation frequency estimates for Atlas 14. The precipitation frequency data is shown in **Table 15-1** and can be obtained directly from NOAA NWS Atlas 14 website at the following link:

https://hdsc.nws.noaa.gov/hdsc/pfds/pfds_printpage.html?lat=30.4333&lon=-97.7692&data=depth&units=english&series=pds

Table 15-1: Atlas 14 Precipitation Frequency Estimates

<i>Atlas 14 Precipitation Frequency Estimates (inches)</i>							
Duration	Average Recurrence Interval (years)						
	<i>1</i>	<i>5</i>	<i>10</i>	<i>25</i>	<i>50</i>	<i>100</i>	<i>500</i>
<i>5-min</i>	0.428	0.656	0.779	0.960	1.11	1.27	1.68
<i>10-min</i>	0.680	1.05	1.24	1.53	1.78	2.04	2.66
<i>15-min</i>	0.861	1.31	1.56	1.91	2.21	2.53	3.33
<i>30-min</i>	1.22	1.85	2.18	2.68	3.08	3.52	4.67
<i>60-min</i>	1.59	2.43	2.89	3.56	4.11	4.72	6.39
<i>2-hr</i>	1.89	3.05	3.69	4.66	5.49	6.43	9.07
<i>3-hr</i>	2.05	3.42	4.19	5.38	6.41	7.59	11.0
<i>6-hr</i>	2.35	4.05	5.03	6.54	7.86	9.41	13.9
<i>12-hr</i>	2.70	4.67	5.79	7.53	9.05	10.8	16.0
<i>24-hr</i>	3.10	5.31	6.56	8.48	10.1	12.1	17.8

Intensity-duration-frequency data for rational method calculations shall be determined based on the cubic spline interpolation method of the log-log precipitation values. The intensities determined using the rainfall depths listed in **Table 15-1** and the Intensity values are shown in **Table 15-2**.

Table 15-2: Atlas 14 Intensity Values

<i>Atlas 14 Intensities (in/hr)</i>								
Duration	Average Recurrence Interval (years)							
	<i>1</i>	<i>5</i>	<i>10</i>	<i>25</i>	<i>50</i>	<i>100</i>	<i>200</i>	<i>500</i>
<i>5-min</i>	5.16	7.96	9.46	11.6	13.4	15.4	17.4	20.3
<i>10-min</i>	4.10	6.36	7.56	9.30	10.7	12.3	13.9	16.1
<i>15-min</i>	3.47	5.32	6.32	7.72	8.92	10.2	11.5	13.4
<i>30-min</i>	2.46	3.76	4.44	5.42	6.22	7.08	8.04	9.42
<i>60-min</i>	1.60	2.47	2.94	3.61	4.16	4.76	5.45	6.46
<i>2-hr</i>	0.955	1.55	1.88	2.37	2.79	3.26	3.80	4.61
<i>3-hr</i>	0.693	1.16	1.42	1.82	2.17	2.57	3.04	3.73
<i>6-hr</i>	0.397	0.687	0.853	1.11	1.34	1.60	1.90	2.37
<i>12-hr</i>	0.228	0.396	0.492	0.640	0.770	0.925	1.10	1.37
<i>24-hr</i>	0.130	0.225	0.279	0.360	0.433	0.513	0.613	0.758

Quantities. The exact numbers of drainage basins, outfalls, and stormwater management facilities (detention facilities, weirs, etc.) shall be determined by the DB Contractor.

Tasks and Submittals. The objective is to maintain the existing drainage patterns and obtain approval of the drainage and stormwater management design. The DB Contractor shall:

- Design and generate construction plans documenting that the drainage system has been designed in accordance with this *Technical Provision 15*;
- Acquire all permits, including but not limited to the USACE Section 404 Permit, TCEQ WPAP Permit, and the TCEQ TPDES permit, as applicable; and
- Prepare a Drainage Report that documents analysis and achievement of a no adverse impact design at each project outfall from the ROW.

Refer to *Technical Provision 9* for more specific requirements related to Project permits.

15.3 Design and Construction Criteria

15.3.1 Specific Requirements

At a minimum, the drainage and stormwater management system shall meet the following requirements.

General. The DB Contractor shall design and construct a drainage system that provides a well-drained corridor and a safe environment for the individuals who construct, use, and maintain the corridor, ensures no adverse impacts, promotes best management practices through enhanced ecological performance and reduces long term operations and maintenance costs of the system. The design and construction of all drainage structures and appurtenances shall adequately address the design improvements, functionality, durability, low life-cycle costs, ease of maintenance, maintenance access, safety, aesthetics, protection against vandalism, and environmental concerns, according to the Contract Documents, the referenced standards and guidelines, and the requirements of this *Technical Provision 15*. The DB Contractor shall abide by and fulfill the drainage system requirements, while at the same time meeting the requirements of other Project design elements (construction staging, etc.). The DB Contractor will be required to upgrade/replace all inlets and pipes that receive flow from or are impacted by the Work when they do not meet the requirements in *Technical Provision 15*. If the Project Design does not require physically adjusting or replacing an existing drainage structure or if the existing structure is not receiving an increase in flow as a result of the project then improvements/upgrades to that existing drainage structure shall not be required. All evaluations will use Atlas 14 data for pre- and post-project assessments. The Atlas 14 change in best available precipitation depth data will not be considered as a change in project condition.

Adverse Impacts. The DB Contractor shall evaluate all features of the roadway facility and confirm no adverse impacts to adjacent and surrounding properties, both upstream and downstream of the Project for

the 2-, 10-, 25-, 50-, and 100-year frequency events. A baseline of existing conditions will be made and any changes to the existing conditions will be compared to the baseline existing conditions in order to evaluate adverse impacts. At a minimum, adverse impacts to properties shall be assessed using the following process and criteria for each Project outfall. Additionally, the Project drainage and stormwater management system shall conform to the criteria specified in Exhibit C - Attachment 15-1 – Impact Assessment Evaluation Requirements.

- **Hydrologic Impacts:** The hydrologic impacts will be summarized at each outfall by comparing the existing and proposed peak flows for the 2-, 10-, 25-, 50-, and 100-year frequency events at a junction at the downstream ROW and/or easement limits.
- **Hydraulic Impacts:** The hydraulic impacts will be summarized at each outfall by comparing the pre-project and post-project water surface elevations for the 2-, 10-, 25-, 50-, and 100-year frequency events at the upstream and downstream ROW and/or easement limits. The hydraulic impacts will summarize the downstream system capacity and functional changes to system. The DB Contractor shall obtain any and all permits/releases required for discharge.
- **Sheet Flow Impacts:** Sheet Flow impacts for the corridor will be reviewed and summarized. The design cross sections shall be reviewed for impacts to natural drainage patterns and the roadway and drainage design shall provide accommodations to maintain the existing drainage patterns. The roadway shall not limit the ability of adjacent property to drain.
- **Waterway Stability Impacts:** Waterway stability impacts for the entire corridor will be reviewed and summarized with consideration for the waterway reach beyond the ROW or easement limits.
- **Outfalls:** All outfalls will be assessed to ensure they do not increase local erosion for the 2-, 10-, 25-, 50-, and 100-year frequency events. Local erosion and energy dissipation treatments will be provided at all outfalls where post-project velocities exceed pre-project velocities and are greater than 6 fps in the design event. Review and documentation of channel stability will follow guidance of the TxDOT Hydraulics Manual Chapter 7.
- **Floodplain Storage Impacts:** The loss of effective regulatory floodplain storage volume shall be quantified for each outfall. Compensatory excavation for mitigation of floodplain fill will not be required. Fill within the regulatory floodway is prohibited.
- **Risk Potential:** An assessment of risk potential on adjacent properties and the receiving waterways shall include, at a minimum, the following: an assessment and narrative description of the impacts of the above parameters; review of the City of Austin Flood Complaints Data and Erosion Site Data and known issues; system capacity; and impacts to developed properties and structural improvements.
- **Approvals and Permits.** The DB Contractor shall fully comply with applicable Laws related to drainage and shall acquire all applicable Governmental Approvals and permits; including, but

not limited to the USACE Section 404 Permit, TCEQ WPAP Permit, and TCEQ TPDES permit, as applicable. See Technical Provision 9 for further Environmental Requirements.

Damage and Erosion. The DB Contractor shall evaluate and determine effective protection for the roadway, subgrade, and highway structures from water damage and shall provide protection from erosion of the side slopes, both on the Project and on adjacent property.

Drainage Flow. The DB Contractor shall maintain historic drainage patterns through the design and construction of a drainage system within the ROW (including outfalls) to accommodate all stormwater that originates within or that reaches the ROW, from additional properties and easements from the contributing drainage areas.

Design and Check Storm. All drainage structures and storm systems shall be indicated on the Final Design Plans, and evaluated for safety of the drainage and roadway structures and downstream development during the check storm per Chapter 4 Section 6 of the TxDOT *Hydraulic Design Manual*. This shall include hydraulic storm sewer calculations. The check storm shall be the 100-year frequency event fully developed offsite conditions. The evaluation shall include calculations for inlets, pipes, and ponds. However, the DB Contractor shall provide sufficient stormwater conveyance and/or storage for storm events, as identified in this Technical Provision 15, that meet or exceed the design frequency criteria to keep roadways passable and to not create adverse impacts.

Emergency Overflow. The DB Contractor shall confirm if emergency overflow exists for all proposed, adjusted, or widened general purpose lanes, ramps and direct connectors. Emergency overflow is defined as the ability for stormwater to flow unrestricted to an acceptable outfall if the drainage system is not operating. Typically this occurs on depressed roadway with no emergency overflow. A roadway is considered depressed if water has nowhere to drain when the depth of water exceeds the curb height (typically 6-inches). Slotted barriers are an option for creating emergency overflow within these sections and are preferred to wall system reconstruction to install additional inlets. Slots shall be placed at heights that meet the 50-year ponded shoulder width criteria. Hydraulic calculations for the slots demonstrating compliance with the 50-year criteria shall be included with the design plans.

Hydroplaning Analysis. The DB Contractor shall provide hydroplaning calculations for all moderate and high risk areas on the project including superelevation transitions. Initial driver speed shall conform to the design speed in DBA Exhibit C Attachment 11-1, and areas of merging shall use the main lane or higher adjacent design speed. The FDOT (see above reference section) approach for estimating reductions in predicted driver speed based on rainfall intensity is acceptable. A pavement texture depth of 0.05 inches is an acceptable assumption unless final pavement design indicates otherwise. The DB Contractor may suggest an alternative approach based on accepted industry practice for review by the Mobility Authority.

Pump Stations. Pump stations shall not be used unless approved by the Mobility Authority. The existing vaulted water quality ponds that contain pumps (Lake Creek 1A and Hymeadow 2A) shall be redesigned to not require pumps.

Manholes and Inlets. The DB Contractor shall avoid designing manholes or inlets within pavement. Manholes will be permitted within shoulder pavement unless otherwise approved by the Mobility Authority.

Removals and Voids. Existing storm sewer pipes that are located under existing pavement that are not used for the final drainage system shall be removed or may be plugged and abandoned in place by filling with controlled low strength material or flowable backfill. Existing pipes not under existing pavement, and all existing inlets, slotted drains, and catch basins not used for the final drainage system shall be removed per this Technical Provision 15. The DB Contractor's plans must clearly show all existing drainage features and callout whether the feature will remain, be abandoned, be removed, or be tied into the proposed drainage system.

Slotted Drains. The DB Contractor shall not use slotted drains on this Project. Existing slotted drains that are not impacted physically or by receiving increased flows and are operating per Project requirements may remain.

15.3.2 General Purpose Lanes, Ramps, Collector Distributers and Direct Connector Drainage

The general design criteria associated with the express lanes, general purpose lanes (unless otherwise stated express lanes are considered general purpose lanes for the purposes of defining drainage criteria), ramps, collector distributers, and direct connector construction must comply with the following requirements:

- Culverts and bridges shall be designed to convey a minimum 50-year without inundating the roadway pavement. Bridges shall also be designed to accommodate the 200-year and 500-year events without complete structural failure.
- Design and Check storm frequency events along with frequency event flow rate and water surface elevations shall be indicated on the final plans.

15.3.3 Frontage Road Drainage

The general design criteria associated with frontage road construction shall comply with the following requirements:

- The check storm shall be the 100-year frequency event and shall also be evaluated and indicated on the final plans.

15.3.4 City and County Cross-Streets Drainage (Minor Collectors)

The general design criteria associated with intersecting City and County cross-street construction must comply with the local jurisdiction's criteria. If no jurisdictional criteria exist, the general design criteria

associated with intersecting City and County cross-street construction must comply with Frontage Road Design requirements.

Table 15-3: Design Frequencies

ROADWAY CLASSIFICATIONS		<i>General Purpose Lanes, Ramps, Collector Distributors, and Direct Connectors</i>	<i>Frontage Roads</i>	<i>City and County Cross-Streets (Minor Collectors)</i>
DESIGN FREQUENCIES				
<i>Storm Sewer</i>	With Emergency Overflow	10-year	10-year	10-year
<i>Inlets</i>		10-year	10-year	10-year
<i>Laterals</i>		10-year	10-year	10-year
<i>Storm Sewer</i>	Without Emergency Overflow	50-year	25-year	N/A
<i>Inlets</i>		50-year	25-year	N/A
<i>Laterals</i>		50-year	25-year	N/A
<i>Median Ditches</i>		10-year	N/A	N/A
<i>Roadside Ditches & Open Channels</i>	Rural Roadway Section	N/A	10-year	10-year
<i>Small Culverts</i>		N/A	10-year	10-year
<i>Allowable Ponding Width</i>		Width of shoulder + 1/2 width of adjoining lane	Width of shoulder + width of adjoining lane	Width and depth that will allow passage of one lane of traffic in each direction
<i>Culverts (FEMA)</i>		50-year	10-year	10-year
<i>Bridges (FEMA)</i>		Accommodate 200-year & 500-year without complete structural failure	25-year* (no overtopping)	25-year*

*Criteria applies to bridge class culverts as well. The impact of 100-year flood shall be evaluated

15.4 Conveyance System Design

15.4.1 Design Criteria

The DB Contractor shall use a minimum pipe size of 18 inches for laterals and 24 inches for trunk lines, except for underdrains for retaining walls and closed drainage on bridges. A trunk line is any pipe receiving flow from 3 or more inlets. Existing pipes and inlets that will not be physically impacted, do not receive increased runoff, and meet all other criteria are not required to be replaced solely for this minimum size provision. All evaluations will use Atlas 14 data for pre- and post-project assessments. The Atlas 14 change in best available precipitation depth data will not be considered as a change in project condition. Existing and proposed conditions shall be assessed following a consistent hydrologic methodology. Design requiring restrictions in pipe size such as water quality facilities shall incorporate easily accessible restrictors with 24 inch or larger pipe.

15.4.2 System Material

Materials. Pipes shall be any of the following materials, as qualified herein:

- CMP pipe material is only allowed on residential driveways.
- Materials for culverts crossing general purpose lanes, ramps, or frontage roads must be reinforced concrete pipe.
- Materials for other culverts (such as driveways, sidewalks, or local streets) that are not reinforced concrete pipe may be determined based on engineering analysis as approved by the Mobility Authority.
- Culverts crossing beneath railroad tracks must be of a material approved by the Railroad.

A change in pipe class type or material will be allowed only at accessible junctions or manhole locations. The DB Contractor will provide D-load structural loading calculations for pipes in fill over 23 feet. The DB Contractor will also provide structural loading calculations for existing and proposed pipes impacted by increased loading caused by proposed walls. This includes pipes within the zone of influence beneath walls. The zone of influence is the area underlying walls and extending in front of walls within a zone defined by a 1H:1V slope extending downward and away from the toe of the wall.

Curb Inlets. Three bay PCU and PCO inlets are prohibited. Two bay inlets shall have the second inlet on the upstream side only.

15.4.3 Outlet Protection

All conveyance system outlets shall be designed to minimize downstream erosion. Velocity protection and control devices shall be designed at a minimum according to the guidelines of the TxDOT *Hydraulic Design Manual*. For all outfall locations, the allowable velocity shall be calculated, and appropriate erosion protection and/or energy dissipaters shall be provided in accordance with the TxDOT *Hydraulic Design Manual* and FHWA HEC-14.

Safety Aprons. All culverts entrances and exits shall be protected with an inlet or headwall. Culvert ends located outside of the clear zone do not need cross pipes. If culvert ends are located within the clear zone, they must be treated in accordance with the current TxDOT guidelines and the AASHTO *Roadside Design Guide*.

Safety End Treatments. All pipes less than 54 inch diameter and all boxes less than 4 feet tall shall have safety end treatments in accordance with TxDOT standards.

15.4.4 Outfall Channel Improvements

The DB Contractor shall design outfall channels carrying storm drainage from the fully developed offsite condition, to cross-channels for a 50-frequency event. For channels draining over 200 acres, the channel section must be capable of conveying a 100-frequency event for drainage conditions. The appropriate Governmental Entity must approve all improvements and/or ties to major cross-channels, ditches, or creeks in writing. The DB Contractor shall use a starting tailwater water surface elevation for the design of storm sewer systems, which outfall to channels, based on the frequency of the channel, as defined by TxDOT's *Hydraulic Design Manual*.

15.5 Bridge Hydraulics

The DB Contractor shall complete and submit to the Mobility Authority, as a part of the Formal Design Review, detailed bridge and bridge class hydraulic computations for both existing and proposed conditions.

Bridge Drainage: Bridge deck drains shall be provided when drainage design requires drain inlets located on bridge superstructures. Drain pipes shall be hidden from lateral view between girders, and hidden from all views at substructure bents and abutments, with the exceptions at the two bridges listed below. At the following bridges, the drain pipe may be attached to the exterior of the existing cap and column on the U-turn side:

- Lakeline Mall Drive Overpass (widening)
- Pecan Park Blvd. Overpass (widening)

Exposed drain pipes shall be UV rated PVC pipe, painted in accordance with Attachment 10-1 Aesthetic Design Guide.

All bridges with shared use paths shall incorporate deck drains. The bottom of bridge deck drains shall have at least 1% slope within the inlet pan/box to the drainage pipe. The DB Contractor shall not use an open rail system on this Project. The roadway drainage design shall include bridge approach drains to intercept gutter flow at both ends of the bridge. Stormwater flowing toward the bridge from approaching roadway shall be intercepted prior to the approach slab. The inlets and catch basins shall conform to the requirements of this *Technical Provision 15*.

15.6 Open Channels and Ditches

Roadside and Median Ditches. Culverts and/or inlets shall be used to outlet drainage in low spots in the median. Maintain slope rates as required in *Technical Provision 11.5.5*. Unless otherwise approved by the Mobility Authority the flowline of the ditch shall be 2 feet below pavement edge or 6 inches below the top of top of erodible pavement section for general purpose lanes, express lanes, speed change lanes, auxiliary lanes, ramps, direct connectors, collector-distributor, and frontage roads; subgrade for cross streets, whichever is greater. This ditch depth criteria is not required along the MoPac Corridor.

Grass Lining. Whenever possible, all roadside and median ditches shall be grass-lined to help filter out pollutants before drainage enters any outfall.

Design Requirements.

Minimum ditch design requirements are as follows:

- Minimum longitudinal gradient: greater than or equal to 0.5%, in addition the minimum flow velocity for the design event shall be no less than 3 ft/s.
- Channels shall be designed to keep channel velocities under 5 feet per second (fps), thereby reducing erosion potential. The DB Contractor shall review and consider design opportunities to either modify the channel design to reduce the velocity or to implement appropriate BMPs to mitigate the high velocity flows. Ditch lining shall be designed to accommodate the design flow and velocities in accordance with the TxDOT *Hydraulic Design Manual* guidance on permissible shear stress and retardence class for lining materials.

The following ditch design requirements should be used where possible:

- Where possible, use trapezoidal channels with a flat bottom to maximize bottom width and avoid downward cutting.
- Long and steep channel longitudinal gradients shall be reduced where possible. The longer and steeper the longitudinal gradient, the greater the erosion potential. As a general rule, the erosion hazard will become critical if the slope lengths exceed the following values:
 - 0%–7%: 300 feet
 - 7%–15%: 150 feet
 - 15% or over: 75 feet
- Channel terracing is encouraged to establish flatter channel longitudinal gradients and reduce velocities.

Swales and drainage channels should be designed with the following features:

- Maximize overland sheet flow conditions.
- Use wider and flatter channels to avoid fast-moving channel flow.
- Increase the channel flow path.
- Reduce channel gradients to decrease velocity.
- Orient flows over pervious soils whenever possible to increase infiltration.
- Grade slopes to be rounded at the top and bottom of the slopes.
- Increase surface roughness to slow velocity.

15.7 Stormwater Management System

15.7.1 Detention and Water Quality Design

Water Quality BMPs. The use of PFC is prohibited anywhere except MoPac. All water quality basins shall be batch detention unless approved by the Mobility Authority.

Water Quality Treatment Calculations. Water quality Treatment calculations shall be performed in accordance with TCEQ requirements, unless otherwise noted. TCEQ policy is to count impervious cover both on top of and under bridges, overpasses and underpasses. Percentage Total Suspended Solids (TSS) Annual load removals described in Exhibit C - Attachment 15-1 Impact Assessment Evaluation Requirements are environmental commitments. However, the Project shall achieve no net increase in TSS annual loading from 1987 baseline impervious cover (with the exception of Rattan, Shoal, and Bull creeks) to Ultimate Design impervious cover. For the Rattan Creek watershed, the DB Contractor shall use the 1999 baseline impervious cover. For Shoal Creek and Bull Creek, the DB Contractor shall use the 1992 baseline impervious cover. These baselines acknowledge the previous impervious cover permitted by TCEQ without TSS treatment. The Ultimate Design impervious cover (referred to as Ultimate Post Project impervious cover), excludes the FM620/SH 45 direct connectors and associated improvements.

No net increase shall be assessed at each Point of Interest (refer to Exhibit C - Attachment 15-1 – Impact Assessment Evaluation Requirements). The West Cow Path Pond and Seton Pond are subject to a memorandum of understanding with the City of Austin and shall also be designed in accordance with *City of Austin Drainage Criteria Manual* and *City of Austin Environmental Criteria Manual*.

Ground Water in Ponds. If ground water is a known issue or an issue identified during design and construction, DB shall provide low flow bypass of pond basin, as coordinated with and approved by the Mobility Authority.

Ponds. Ponds may be required to address water quantity treatment and stormwater quantity and flow rate control. The design shall comply with the requirements of the FHWA HEC-22 and the best management practices for such facilities. See Technical Provision 9 for more details on water quality permits and requirements. Specific water quality and mitigation requirements shall conform to the criteria specified in Exhibit C - Attachment 15-1 – Impact Assessment Evaluation Requirements.

General pond requirements include the following. If existing ponds are not in accordance with these requirements, they shall be modified in accordance with this Technical Provision 15:

- All ponds shall utilize earthen side slopes of 4H:1V or flatter unless otherwise approved by the Mobility Authority. Vertical walls may be used if required to stay within the existing right-of-way.
- For ponds converted from underground vaults, vertical walls may be used where space is restricted. The DB Contractor shall provide vehicular access for maintenance purposes.

- Ponds shall have a minimum bottom slope of 2%, unless otherwise approved by Mobility Authority.
- Pond basins should have a permanent maintenance equipment access ramp whose slope should not exceed 4:1 (H:V). The minimum width is 12 feet for a ramp into each basin of the facilities.
- Unless otherwise approved by the Mobility Authority access drives should be a minimum of 12 feet wide and not exceed 15% grade. Grade changes and alignment should be considered in the design of the access drive. A turning radius not less than 50 feet should be included for horizontal alignments. Grade changes shall not exceed 12% for vertical alignments. The access drive should include a means for equipment to turn around when located more than 200 feet from a paved roadway. Access drives shall be cleared, graded and stabilized.
- Unless otherwise approved by the Mobility Authority ponds should have a staging area for maintenance activities of not less than 800 square feet if the storage volume of the pond exceeds 2,000 cubic feet. The staging area should be located adjacent to the water quality facility and access drive. The staging area should be cleared, graded and revegetated, with slopes not exceeding 10% in any direction.
- If fences are used to control access to water quality facilities, gates, a minimum of 12 feet wide and with approved locks, shall be provided to allow access for maintenance equipment.
- Brown PVC chain link fencing shall be added at proposed pond locations along vertical walls to protect from falls, in addition to required roadway protection measures. Refer to *Exhibit C – Attachment 10-1 – 183 North Mobility Project Aesthetic Design Guide* for more detail information on fence types.
- Ornamental wrought iron fencing shall be added to surround the pond and maintenance areas at all ponds adjacent to pedestrian facilities. Refer to *Exhibit C – Attachment 10-1 – 183 North Mobility Project Aesthetic Design Guide* for more detail information on fence types.
- Existing fences and gates shall be replaced. Existing fences adjacent to pedestrian facilities shall be replaced with ornamental wrought iron fencing. Existing fences not adjacent to pedestrian facilities shall be replaced with brown PVC chain link fencing.
- No new underground systems or pumped systems shall be permitted unless otherwise approved by the Mobility Authority.
- Any existing Hazardous Material Traps will be removed and replaced with manual valves on the facility outlet structure. All ponds will have manual valves at a readily accessible location as approved by the Mobility Authority. The valve type shall be as coordinated with and approved by the Mobility Authority.
- All existing ponds shall be surveyed to confirm the volumes and configuration. If the surveyed stage-storage curve conflicts with the record drawing or permitted plan stage-storage curve the

surveyed stage-storage curve shall be used for impact analysis. The total required water quality volume shall be based on the permitted water quality volume, not the volume from the survey.

- The DB Contractor is responsible for ensuring compliance with TCEQ Dam Safety Requirements and coordinating with TCEQ as required.

15.7.2 Underground Systems

Inline or underground detention and or water quality ponds will not be permitted unless approved by the Mobility Authority.

15.8 Stormwater Pollution Prevention Plan (SW3P)

The DB Contractor shall develop, construct, and maintain a stormwater management plan that is in compliance with applicable Law and shall procure all Governmental Approvals in connection therewith. The stormwater management plans shall include provisions for control of sedimentation and erosion, runoff, Storm Water Pollution Prevention Plan (SW3P), and water quality during DB Work, construction and for the life of the Project. See *Technical Provision 9* for more details on SW3P permits.

TPDES Compliance. The DB Contractor shall prepare a SW3P, as required by TPDES. Detailed limits of the erosion control items must be shown on the SW3P plan sheets.

Submittal. The SW3P shall be submitted along with the DB Contractor's certification prior to beginning construction activities.

Erosion Control. This Project shall meet the TPDES requirements (including preparation of and compliance with an SW3P) to control erosion and sediment. The DB Contractor shall submit all parts of the TPDES application to the appropriate agency and send a copy of the application to the Mobility Authority.

15.9 Water Resources Permits

DB Contractor Responsibility. The DB Contractor is responsible for obtaining all stormwater-related permits required for construction of the Project. Typically, this will include permits from the USACE, TCEQ, and TPDES. All technical data and drawings necessary for permitting agency review shall be provided by the DB Contractor to support and complete the permit submittals. In the case of watershed management organizations, cities, and counties (which have no statutory permit authority over State highway projects), the DB Contractor shall coordinate with them in a customer-friendly manner, document coordination efforts, and provide technical data if requested. See *Technical Provision 9* for more details on Water Resource Permits. Full documentation of all meetings and decisions is to be submitted to the Mobility Authority, and these activities and submittals must be coordinated through the Mobility Authority.

Wetland Impacts and Mitigation. The DB Contractor’s responsibilities related to wetland impacts and mitigation shall be in accordance with Technical Provision 9.3.10. To the extent that wetland mitigation is required, wetland mitigation areas shall be prepared and drafted in detail by the DB Contractor so the information can be electronically merged into the Project’s As Built Plans.

15.10 Coordination of Water Resources Issues

DB Contractor Responsibility. Projects with significant water resources impacts or wetland impacts require considerable coordination to find and develop acceptable mitigation sites. The DB Contractor shall ensure that adequate coordination occurs so the Project is not delayed by permitting issues.

Coordination. The DB Contractor shall coordinate all water resource issues, including meetings related to water resources engineering, meeting minutes, and memoranda for the record.

Water Resources Log. The DB Contractor shall maintain a log of the Project’s water resources issues, including copies of all pertinent correspondence. Copies of correspondence shall be provided to all personnel as necessary to ensure good project coordination. At Final Acceptance, the DB Contractor shall provide a complete copy of the log to the Mobility Authority.

15.11 As-Built Drainage Plans

Items. The DB Contractor shall prepare As Built Documents, notes, and details that include, but are not limited to the following items:

- Drainage area maps.
- Hydraulic plan and profiles sheets.
- Hydrologic and hydraulic notes and tabulations.
- Design of storm sewer systems.
- Culvert designs and risk analysis.
- Ditch and outfall plan and cross section sheet(s).
- Detention pond designs, plans, cross section sheets, and details.
- Water quality facility designs, plans, calculations, and details.
- Designs for wetland and floodplain mitigation.
- Special drainage detail sheet(s).
- Erosion Control Plan and details.
- Completed permit applications.
- Correspondence file.

- All modified reports and models.

15.12 Submittals

Table 15-4: Submittals to Mobility Authority

Submittals	Submittal Schedule	Mobility Authority Action	Reference Section
30% Drainage Report	With Preliminary (30%) Design Submittal	Review and comment	15.2
65% Drainage Report	With Intermediate (65%) Design Submittal	Review and comment	15.2
100% Drainage Report	With Final (100%) Design Submittal	Review and comment	15.2
Bridge and Bridge Class Hydraulic Computations	As part of Formal Design Review	Review	15.5
SWPPP	Prior to beginning construction activities	Review	15.8
Water Resources Log	At Final Acceptance	Information	15.10

16.0 PAVEMENT MARKINGS

16.1 Referenced Manuals, Standards, and Guidelines

Pavement Marking Specifications. For permanent striping and interim (temporary) striping, the DB Contractor shall use pavement marking materials that conform to the following specifications and guidelines:

- AASHTO A Policy on Geometric Design of Highways and Streets
- AASHTO Roadside Design Guide
- Texas Manual on Uniform Traffic Control Devices (TMUTCD)
- TxDOT Standard Specifications for Construction and Maintenance of Highways, Streets, and Bridges
- TxDOT Roadway Design Manual
- TxDOT Pavement Marking Handbook
- TxDOT Traffic Engineering Standard Plan Sheets
- City of Austin Standards, Series 800 – Traffic Controls

16.2 General

These general requirements apply to both interim and permanent pavement markings.

Functional Requirements. The DB Contractor shall be responsible for pavement markings in accordance with the requirements identified in this Technical Provision 16.

The DB Contractor shall design, furnish, and install pavement striping, delineation, and pavement markings on all roadways within the Project limits that:

- Provide for the orderly and predictable movement of all traffic.
- Provide for the safe and uniform operation of vehicles in the traffic stream.
- Provide for the orderly and predictable movement of pedestrians and bicyclists.
- Are consistent in type, color, dimensions, location, and reflectivity with all other roadway pavement striping.
- Have been coordinated with the System Integrator (SI).

Designs. The DB Contractor shall prepare interim and permanent pavement marking designs. The designs shall include edgeline striping, lane line striping, arrows, words symbols/shields, delineators, object

markers, and other markings consistent with the needs of the Project, and shall conform to the TMUTCD and TxDOT's requirements. The plans shall include all markings necessary to guide drivers, pedestrians, and cyclists through the Project, based on the DB Contractor's project staging, and identify the removal of any existing conflicting pavement markings.

Annual Testing and Correction. Until Final Acceptance the DB Contractor shall test the pavement markings within the Project limits each spring (March–April), beginning with the spring after initial installation, and take whatever corrective actions are necessary to bring the pavement markings into compliance with the requirements herein.

Warranties. The DB Contractor shall meet the Warranty requirements for pavement markings as specified in Technical Provision 3.

16.3 Pavement Marking Materials

16.3.1 Permanent Pavement Markings

General. Permanent pavement markings shall meet the following requirements:

- All express lane and general purpose lane edgeline pavement markings shall be 6 inches raised reflectorized profile markings in accordance with TxDOT Standards. Milled-in rumble strips shall not be used.
- All lane lines separating the general purpose lanes shall be 6-inch reflectorized markings in accordance with TxDOT Standards. Contrast pavement markings are required on concrete pavement in accordance with TxDOT Standards.
- The lane line separating the express lanes shall be 9-inch (6-inch white with minimum 1.5inch black) contrast pavement marking 3M™ tape (Stamark™ High Performance Contrast Tape Series 380IES) or equivalent in accordance with TxDOT Specifications.
- All final edgeline delineation, turn arrows, object markers, gore striping, lane line delineation, crosswalks, and bicycle lane markings shall be permanent reflectorized pavement markings and include raised reflective pavement markers as shown on TxDOT Standard Plans. For facilities with posted speeds greater than 45 miles per hour, edgeline pavement markings shall consist of raised reflectorized profile markings.
- All pavement markings shall be designed and installed to meet TxDOT Standards.
- Continental high-visibility crosswalks shall be provided at each location requiring installation of a crosswalk.

Materials. Permanent pavement markings on asphalt surfaces shall consist of Type I marking materials. Permanent pavement markings on concrete surfaces shall consist of Type I marking followed by Type II marking materials. Broken lines shall be prefabricated type complying with TxDOT Standard Specification

Item 668. The DB Contractor shall perform retroreflectivity measurements for TY I markings in accordance with TxDOT Standard Specification Item 666 and Statewide Special Specification 6291.

16.3.2 Interim Pavement Markings

General. If weather conditions delay the installation of permanent pavement markings, the DB Contractor shall, after obtaining Mobility Authority approval, install interim pavement markings. If the DB Contractor's project staging requires modification to existing pavement markings to accommodate Traffic Control Plans, the DB Contractor may install interim pavement markings; all instances of interim pavement markings shall require Mobility Authority approval.

Rework. If the Mobility Authority determines that the interim striping is out of tolerance with acceptable standards, the DB Contractor shall take corrective action. Removal of striping shall be performed using equipment and methods that are not detrimental to the final surface, as determined by the Mobility Authority. The DB Contractor shall pay all costs of removing and restriping the interim markings, including the costs of repairing any damage caused to the wearing course by pavement-marking removal.

16.4 Submittals

General. The DB Contractor shall develop permanent striping plans that show sufficient information and details to guide field personnel during striping operations. Prior to the placement of any permanent striping, the striping plans shall undergo the Formal Design Review process as described in Technical Provision 2.

Record Drawings. Permanent striping plans are required in the Record Drawings.

Plan Requirements. At a minimum, the plans shall:

- Show the entire Project or roadway segment to be striped in plan view on individual plan sheets at a scale acceptable to the Mobility Authority; typical sections representative of striping shall not be accepted.
- Include all existing pavement striping for a minimum of 300 feet past the limits of construction and provide adequate transition and tapers to maintain traffic at the design speed.
- Fully show and identify existing striping by type, color, and width. and Provide lane dimensions across the roadway.
- Clearly identify striping to be removed, providing stations and offsets, and/or partial stations as appropriate.
- Fully show and identify all new striping by type, color, and width. Provide lane dimensions across the roadway. Tie all stations and offsets to a construction baseline or survey baseline.
- Locate by station or dimension lines all pavement arrows, words, symbols/shields crosswalks, etc.

- Include design drawings other than TxDOT standard drawings that show details of pavement markings for non-standard pavement marking design (i.e. for express lanes).
- Identify the location of toll sites (including gantries) on the pavement marking plans.

Table 16-1: Submittals to Mobility Authority

Submittals	Submittal Schedule	Mobility Authority Action	Reference Section
Permanent Striping Plans	Prior to the placement of any permanent striping	Review	16.4

17.0 TRAFFIC SIGNALS

This Work includes the design, installation, and construction of any modifications required to existing permanent traffic signals impacted by construction of the Project, including the furnishing, installation, and construction of temporary and permanent signal equipment.; Referenced Manuals, Standards, and Guidelines.

The DB Contractor shall be responsible for traffic signal Work in accordance with the requirements identified in this *Technical Provision 17* and all other pertinent provisions of the Contract Documents, and with the relevant requirements of the following listed standards and provisions, unless otherwise stipulated herein. It is the DB Contractor's responsibility to obtain clarification of any unresolved ambiguity in standards before proceeding with design or construction. Refer to *Technical Provision 22* for details relating to maintenance of traffic signals during construction.

Signals shall be designed, installed, and constructed in accordance with the standards of the City of Austin. The DB Contractor shall make a determination, prior to final design, as to which agency will have jurisdiction and provide the Mobility Authority with documentation indicating agency responsibilities. The DB Contractor shall verify that that all agencies concur with the DB Contractor's documentation.

The DB Contractor shall conform to the latest requirements of the following standards and guidelines in designing and constructing the traffic signals.

- *Texas Manual on Uniform Traffic Control Devices (TMUTCD)*
- TxDOT Traffic Signals Manual
- TxDOT Sample Plan
- TxDOT Engineering Standard Sheets
- *TxDOT Standard Specifications for Construction and Maintenance of Highways, Streets, and Bridges*
- City of Austin Sample Plan and cabling/wiring guidelines
- National Fire Protection Agency (NFPA)
- National Electrical Code (NEC)
- City of Austin Standards, Series 800 – Traffic Controls
- Texas Accessibility Standards (TAS)
- Americans with Disabilities Act (ADA) Standards

17.1 Permanent and Temporary Signal Requirements

General. The DB Contractor shall supply all traffic signal equipment, as well as all other materials required for the complete permanent installation and operation of temporary traffic signals, in accordance with TxDOT Standard Specifications and any applicable Special Provisions, and the standards of the municipality having jurisdiction of signal location, and except as otherwise noted in this Technical Provision 17.

17.1.1 DB Contractor Responsibilities

The DB Contractor shall:

Signal Locations. The DB Contractor shall modify existing signals, when appropriate and as necessitated by design development. This includes, but is not limited to, the following intersections:

- Pedestrian signal modifications at US 183 NB Frontage Road and Pond Springs Road.
- Traffic signal modifications at US 183 SB and Spicewood Springs Drive.
- Traffic signal modifications at US 183 NB and Oak Knoll Drive.
- Traffic signal modifications at US 183 SB and Duval Road.
- Traffic signal modifications at US 183 SB and Balcones Woods Drive.
- Traffic signal modifications at US 183 NB and Braker Lane.

Design and Phasing. Design and implement any temporary traffic (vehicular and pedestrian) signal design or any phasing required for traffic management during construction. Coordination with the City of Austin is required for any temporary signal design or phasing as a part of this project, as the City of Austin is responsible for operations and maintenance of all existing traffic signals within the Project limits.

Mobility Authority Review. Prepare plan sheets for all temporary and permanent signal system installations/modifications, including proposed temporary signal pole detection and head placements, and submit to the Mobility Authority for review prior to final approval by the City of Austin.

Electrical Permit. Obtain an electrical permit for all signal system modifications.

Implementation. Perform all Work to implement the approved temporary and permanent changes, including relocating signal heads.

Inspection. Prior to implementing any temporary phasing, provide a 72-hour notice to the local agency having jurisdiction over signal inspection. Contact City of Austin Signal Department for inspection of all permanent traffic signals at least three weeks before scheduled activation. Items needing repair from inspection shall be addressed within ten days. Upon completion of repairs performed by the DB Contractor,

contact City of Austin Signal Department for a follow up inspection and to reschedule a new activation date approximately 10 days after the follow up inspection.

Signal Timing and Cabinet Wiring. At the time of installation, the DB Contractor shall program the traffic signal controller, with timings provided by the City of Austin, and install the controller in the cabinet. (timing changes during construction will be made remotely by the City.) Pre-timed operation is not a viable option. The DB Contractor shall coordinate with the City before making any wiring changes to the traffic signal equipment and shall implement field wiring changes including supply and installation of cable deemed necessary by the City.

Detection. The DB Contractor shall maintain all vehicle, pedestrian, bicycle, etc. detection at all times during construction and collaborate and coordinate any changes in detection operation with the City of Austin. The DB Contractor shall revise location of all detection equipment as needed based on temporary stop bar locations.

Interconnection. All existing interconnections shall be maintained throughout construction. Should the Project impact any existing interconnections, the DB Contractor shall ensure replacement interconnections are complete prior to disconnecting any existing interconnections. Temporary interconnections are subject to the approval of the Mobility Authority and the City of Austin. The DB Contractor shall coordinate with the City of Austin to determine which traffic signals are interconnected. If the Duct Bank is used for the interconnection of traffic signals, separate ground boxes at the controller locations shall be provided for the interconnection circuits.

ITS Devices. The City of Austin maintains ITS devices along the corridors. Access and communication to the CCTV cameras shall be maintained throughout the project allowing the City to remotely monitor traffic conditions. All other ITS devices shall remain operational when feasible.

Salvage. Salvage all temporary signal system installations and deliver them to the City of Austin. Provide to the Mobility Authority written acknowledgment that all salvaged system elements have been delivered to a designated location as directed by the local agency.

Ground Boxes. Ground boxes shall be constructed with aprons in all areas other than within sidewalk, paved areas, or riprap. A ground box near traffic signal controller foundation to be a stacked Ty D, with apron (if required above), or larger to provide adequate space for City of Austin to install fiber to cabinet.

Utilities. Locate and mark all underground utilities prior to and during any signal installation Work in accordance with Technical Provision 8.

Street Name Signs. Provide illuminated street name signs at all traffic signals.

Permitted Load Requirements. Provide a minimum of 19 feet of vertical clearance at all proposed signal mast arms . In addition, for all proposed signal mast arms to be placed near overpasses, the vertical clearance

shall be 3 to 6 inches lower than the bridge beams to guard the beams from tall loads. In no case shall the traffic signal vertical clearance be less than 15 feet.

17.1.2 Obtaining Equipment

The controllers and controller cabinets for the permanent and temporary signal system installations will be provided by the DB Contractor. All controllers, controller foundations, and controller cabinets shall meet the specifications and standards as directed by the City of Austin as the local agency having jurisdiction over the proposed signal location. The DB Contractor will install the controllers, controller cabinets and wire all temporary traffic signals. The City of Austin will install the controllers, controller cabinets and wire all permanent traffic signals. Any reimbursement fees charged by the City of Austin for this work will be the responsibility of the DB Contractor.

All other traffic signal equipment will be new and will be provided and installed by the DB Contractor.

17.2 Other Requirements

Electric Power Service Coordination. The DB Contractor shall coordinate with the local power supplier to upgrade any electrical service connections if required by the Project. The DB Contractor shall pay the electrical power costs of any temporary or permanent signal system until 120 days after Substantial Completion, after which time the DB Contractor shall transfer billings to the local agency having jurisdiction for the traffic signals.

Permits. The DB Contractor shall obtain any necessary permits for the new signal system installations and modifications to any existing signal systems.

Operation. The City of Austin will remotely operate the signal timing for the temporary signals up to the time when the permanent signals are turned on or the temporary signals are no longer needed. The operation of the new permanent signals will be conducted by the City of Austin. All signal modifications must be approved by the City of Austin.

Maintenance. Maintenance consists of relamping indicators and luminaires, replacing knockdowns, and performing all other Work necessary to keep the signal and interconnect systems operational. Power and communications shall be maintained by the DB Contractor throughout construction. The DB Contractor shall maintain the temporary signal systems (including the controllers and cabinets) until the permanent signal systems are turned on or the temporary signals are no longer needed. The DB Contractor shall notify the City of Austin immediately of any maintenance needs identified on the Project.

Emergency Maintenance. An emergency maintenance task is defined as a situation related to public safety, such as a dark or flashing intersection, improper pedestrian timing, twisted signal heads, exposed wires, and knockdowns. The DB Contractor shall provide emergency maintenance of the signal systems 24 hours a day, 7 days a week. When called or paged by a dispatcher (usually from the Texas Department of Public Safety or the Combined Transportation, Emergency, & Communications Center), the DB Contractor shall

return the telephone call within 15 minutes and respond on-site to initiate emergency repairs within 1 hour of the dispatcher's call. The DB Contractor shall provide the Mobility Authority and the City of Austin with contact names and 24-hour telephone numbers so that they can contact the DB Contractor for emergency service at any time.

Acceptance Test Plan. The DB Contractor shall provide to the Mobility Authority an Acceptance Test Plan (ATP) for all traffic signals. This ATP shall also be submitted to the appropriate Governmental Entity (TxDOT or City of Austin) for approval. The DB Contractor shall conduct testing in accordance with the ATP and document those results to show conformance. Test results shall be submitted to the Mobility Authority.

17.3 Design Plan Requirements

Certification. A Registered Professional Engineer must certify all final plan sheets.

Format. The signal and interconnect system design plans shall include appropriate signature lines, roadway design values, legends and symbols, a list of scales, and a plan index. The appropriate symbols to be used shall follow current TxDOT and City of Austin standards for the temporary and permanent signal systems. The DB Contractor shall arrange a pre-design meeting with the City of Austin Signal Department and the TxDOT Austin District Traffic Operations Office to discuss details of the design requirements. Refer to Technical Provision 2 for submittal requirements.

Plan Items. The signal design plans must show the following items:

- Details.
- Revised, permanent, and temporary intersection layouts.
- Revised, permanent, and temporary wiring diagrams.
- Overhead mast arm signing.
- Interconnect layout.
- Termination Chart (City Type).
- Utility plan sheet.

17.4 Submittals

The signal design plan submittals shall include the following:

- Design plans and special provisions for the permanent signal system.
- Interconnect system plans and special provisions.
- Record Drawings.
- Specifications and detailed shop drawings

- A certificate of compliance with specifications and detailed shop drawings.
- All manufacturers’ Warranties, guarantees, instruction sheets, and parts lists.
- Inspection reports (such as clearance measures, loop tests sheet, voltage drops, and conduit fill calculations).
- ATP test results.

Shop Drawings and Product Data. The DB Contractor shall have readily available for inspection by the Mobility Authority and the City of Austin, all shop drawings, and product data including but not limited to the following items:

- Poles and mast arms (by type and size).
- Service cabinet.
- Luminaires and lamps.
- Traffic signal heads and pedestrian signal heads.
- Accessible Pedestrian Signal pushbuttons.
- Ballasts and photoelectric controls.
- Poles and mast arm finish.
- Detection System
- Fuse holder kits, fuses, and insulating boots.
- Such inspection will not constitute a certification of materials.

Table 17-1: Submittals to Mobility Authority

Submittals	Submittal Schedule	Mobility Authority Action	Reference Section
Acceptance Test Plan (ATP)	As part of the Final Design Submittal	Review and comment	17.2
Signal Design Plan	As part of the Final Design Submittal	Review and comment	17.3
Shop Drawings and Product Data	When Requested	For Information	17.3

18.0 DUCT BANKS & INTELLIGENT TRANSPORTATION SYSTEMS

18.1 Introduction

The DB Contractor shall be responsible for Duct Bank and ITS Work in accordance with the requirements identified in this Technical Provision 18.

A summary of the DB Contractor's responsibilities for design, procurement, and installation of the ITS System is provided in Exhibit C - Attachment 21-1 – Toll Facility and ITS Responsibility Matrix.

The ITS & Duct Bank shall be in accordance with guidelines included in TxDOT Standard Specifications for Construction and Maintenance of Highways, Streets, and Bridges and TxDOT Engineering Standards, particularly as it relates to TxDOT ITS components and cabling that are impacted, relocated, adjusted, or replaced. The Project Design shall include ITS components consistent with the overall location and quantity of ITS components shown on the ITS Concept of Operations and the ITS Schematic provided in Exhibit D – Item 3 – Technical (ITS) and on the US 183 ITS As-Builts in Exhibit D – Item 3 – Technical (As-Builts). The DB Contractor shall disconnect, remove and dispose of existing TxDOT Lane Control Signals.

For Mobility Authority ITS Infrastructure, the DB Contractor shall be responsible for the design of all ITS layouts, which shall include foundations, conduits, electrical services, grounding circuits, support structures, and barrier gate system as outlined further in this Technical Provision 18. The System Integrator (SI) is responsible for the final ITS systems and communications design and the purchase and installation of the Mobility Authority's ITS equipment, including nonintrusive vehicle detectors, dynamic message signs (DMS), and closed circuit television cameras (CCTVs). The DB Contractor shall coordinate with the SI and accommodate the SI's ITS systems design. The DB Contractor's responsibilities as it relates to existing ITS infrastructure is outlined herein. The DB Contractor shall refer to Exhibit C – Attachment 21-1 – Toll Facility and ITS Responsibility Matrix for an outline of responsibilities for proposed Mobility Authority ITS and existing TxDOT ITS.

The DB Contractor shall ensure adherence to the Mobility Authority's ITS Concept of Operations, provided in Exhibit D – Item 3 – Technical (ITS), prior to submittal of the 65% ITS plans.

The DB Contractor shall install the Duct Bank and various foundations, conduits, electrical services, grounding circuits, and support structures to support the ITS System consistent with the ITS Schematic. The DB Contractor shall coordinate with TxDOT and the City of Austin on any adjustments to existing TxDOT and City of Austin ITS infrastructure within the corridor.

The DB Contractor shall provide a level pad at all ITS device locations such that the footprint is large enough to accommodate a single-unit bucket truck to allow for SI access. For all ITS devices, the pad placement shall be placed in a location identified by the SI.

DB Contractor shall provide traffic control devices and safe working conditions for SI during the installation of all Mobility Authority ITS equipment.

18.2 Maintenance of ITS During Construction

The DB Contractor shall be responsible for maintaining and protecting any existing ITS functionality, including those owned by TxDOT or local Governmental Entities, on the Project until Final Acceptance except during system maintenance, crossovers, or other periods approved by the Mobility Authority. For existing ITS impacted by the Project, the DB Contractor shall submit an ITS Implementation Plan as a part of the Intermediate (65%) Design Submittal outlining the interim and final locations of all communications infrastructure and field devices on the Project. Temporary wireless radio connections will be permitted to maintain communications links during construction, provided that all requirements with respect to allowable network downtime are met.

The DB Contractor shall repair each existing communication cable, downed communications link, or electrical conductor that is severed or otherwise rendered not usable within:

- 4 hours if a major/backbone/trunk line.
- 8 hours if a minor/drop fiber line.

18.3 Duct Bank

The DB Contractor shall install either a single or a pair of concrete encased Duct Banks consisting of a total of twelve 2-inch conduits. The DB Contractor may connect to and utilize the existing Duct Bank at each cross street provided the existing Duct Bank is in good repair and serviceable. The Duct Bank shall consist of a single trench or pair of trenches (except in location where directional boring is allowed) within the limits of existing TxDOT Duct Bank. The Mobility Authority and TxDOT shall have infrastructure occupying the same proposed Duct Bank. The Duct Bank shall be located between the travel lanes of the frontage road and the general purpose lanes. Alternative locations for the Duct Bank will be considered and allowed provided that the DB Contractor demonstrates the alternative location provides maintenance access (either for the duct bank itself or the fiber optic and power cables within) without significant disruption to the Mobility Authority's toll operation or traffic in the general purpose lanes. The DB Contractor shall remove or abandon all portions of the existing TxDOT Duct Bank not incorporated into the final Duct Bank.

Directional boring, in lieu of open cut trenching, of duct bank elements is permissible at cross streets and ramps.

At underground locations, a #14 AWG tracer wire shall be installed within the Duct Bank. The Duct Bank may be placed on the underside of bridges at cross street, railroad, and creek crossings. At these aerial locations, the conduit shall consist of rigid metallic conduit.

The Duct Bank system includes the following:

- conduit and fittings.
- conduit hangers (for aerial systems).
- concrete encasement (for underground systems).
- cable vaults, ground boxes, and junction boxes.
- cable racks.
- conductors, cables, and wires for electrical service and tracer wire only (refer to Exhibit C - Attachment 21-1 – Toll Facility and ITS Responsibility Matrix).

The DB Contractor shall interconnect with existing Mobility Authority Duct Banks at 183A and the Mobility Authority's cabinet at MoPac (State Loop 1) and US 183. The Duct Bank shall extend to the eastern terminus of the project for cabinets and terminations to be installed by the Mobility Authority's SI. Underground Cable Vaults (UCV) should be spaced at intervals not to exceed 1,000 feet. At intervals of approximately 1/2 mile the DB Contractor shall install four 2-inch conduit laterals from a UCV to the opposite side of the ROW, where two of the conduits terminate into a Type D ground box and two of the conduits terminate into a Type 1 ground box near the ROW line. This lateral may also be used to provide service to a field device consistent with the ITS Schematic. All laterals shall be perpendicular to the centerline.

Place a large ground box (UCV) at all terminations of the Duct Bank. Placement of these components in the paved area of a roadway is only permitted where consistent with the ITS Schematic. Locations of UCVs and ground boxes may vary to accommodate access to other roadside devices or features. A UCV must be located on an intersection island at each grade separated interchange, preferably in the same island as any existing or proposed traffic signal controller to facilitate future integration.

Power conductors (i.e., electrical service, etc.) shall be run in conduit separate from all other cables and wiring. Power conductors in the duct bank shall be limited to those servicing tolling or ITS infrastructure only; illumination conductor shall not be permitted in the ITS duct bank. All electrical power conductors shall have a ground conductor placed with the power conductor of not less than #6 AWG copper.

The Duct Bank conduit material may only contain fusible HDPE or PVC joints; except as detailed on the plans, the Duct Bank must not contain mechanical or glued joints.

Ground boxes or UCVs, as appropriate, shall be used to terminate all buried conduit runs, and may be shared between the Mobility Authority and TxDOT. Assure ground boxes meet the requirements outlined

in TxDOT's Electrical Details Conduit & Notes Sheets and that space is provided for a one-turn loop of each cable and wire.

Power conduits shall be located on one side of the Duct Bank, with communication conduits on the other side in coordination with the SI. The Duct Bank shall be located outside the Ultimate Design edge of pavement. Ground boxes and UCVs shall not be placed on slopes steeper than 4:1.

ITS Duct Bank shall provide the physical plant for the toll systems communication backbone. A minimum of four, 2-inch conduit shall extend from the nearest large UCV Duct Bank ground box to the toll facility equipment enclosure as required for the toll system.

The DB Contractor shall verify all proposed Duct Bank and conduit by a site visit to each proposed location prior to final plan completion. Verify, avoid or mitigate all conflicts with existing above and underground services.

TxDOT ITS and Mobility Authority ITS and tolling systems are required to utilize separate fiber runs for networking purposes. The SI will be responsible for the procurement, installation, termination and testing of the fiber optic cables in the Duct Bank required for Mobility Authority ITS devices, including fiber optic cable laterals and all fiber and communications required at each Mobility Authority ITS site. The DB Contractor shall install fiber optic cabling required for all TxDOT ITS devices.

18.3.1 Restoration of ITS Network

The DB Contractor shall be responsible for reconnecting TxDOT-owned Project ITS to the existing network, including communications links to Combined Transportation and Emergency Communications Center (CTECC), the TxDOT Austin District, and the TxDOT Traffic Safety Division Office in Cedar Park.

18.3.1.1 Communications Requirements

The DB Contractor shall install a 144-strand single mode fiber optic cable in the Duct Bank for TxDOT ITS devices. All fiber drops to field devices shall consist of 12-strand single mode fiber optic cable. The trunk line fiber may only be spliced at the communication hubs/ITS cabinets unless approved by Mobility Authority. The relocated Project ITS shall be compatible with existing system TxDOT is operating.

The DB Contractor shall be responsible for the planning, design, installation, testing, and operations support of safe and functional ITS for the Project using Good Industry Practice. All components of the ITS shall conform to the provisions of the NTCIP.

The Project ITS shall operate under the Regional ITS Architecture. Communication and interoperability shall be achieved with other Traffic Management Centers (TMC) in the region, such that with appropriate privileges, access to data, command, control, and information sharing can occur among centers. All communication and access of information shall occur in near real-

time (within logistical restraints). The DB Contractor shall submit proposed fiber termination charts to the Mobility Authority for approval.

18.4 Mobility Authority CCTV Cameras

The DB Contractor shall install foundations, conduits, grounding, camera poles, and electrical services for CCTV cameras at the locations specified by the ITS Schematic. The SI will supply and install the cameras, communications, and equipment enclosures.

The DB Contractor shall verify all proposed CCTV locations by a site visit to each proposed location prior to final plan completion. Provide separate conduits for power and communications to each CCTV location; communication cable shall not be in the same conduit with power conductors.

The DB Contractor shall place CCTV poles in locations generally consistent with the ITS Schematic. CCTV locations shall provide full view of the Project, including any Direct Connectors and cross streets, as applicable. The DB Contractor shall notify the Mobility Authority of any deviations of CCTV pole placement greater than 200 feet (radius) and provide a justification for the deviation. The DB Contractor shall analyze horizontal and vertical viewing angle for each CCTV location design. The DB Contractor shall illustrate vertical viewing angles on a roadway profile plot. CCTV poles shall be as tall as required to provide optimal viewing and shall be a minimum 40 feet tall. Poles taller than 45 feet shall be equipped with CCTV lowering devices. Placement of CCTV on High Mast Lighting poles is not permitted unless approved by the Mobility Authority.

Locate CCTV foundations outside the clear zone or within areas protected by metal beam guard fence or concrete traffic barrier.

Safety and Access. The selected locations shall provide reasonable and safe parking and access by service personnel. A paved service bay (safety pullout) shall be provided at camera locations where access is not deemed adequate by the Mobility Authority or its SI.

Technical Requirements. The CCTV camera poles shall be in accordance with TxDOT *Standard Specifications for Construction and Maintenance of Highways, Streets, and Bridges* and the TxDOT Traffic Engineering Standard Plan Sheets for ITS Poles.

18.5 TxDOT CCTV Cameras

The DB Contractor shall provide CCTV cameras along the existing limits of TxDOT ITS on the Project. The DB Contractor shall be responsible for maintaining existing CCTV camera functionality for the duration of the Project until Final Acceptance. If Project results in the need to relocate existing CCTV cameras owned by TxDOT, the DB Contractor shall be responsible for identifying them in the ITS Implementation Plan. The DB Contractor shall be subject to the same safety, access, and technical requirements outlined in *Technical Provision 18.4* above. If the Project results in additional CCTV coverage

needed for TxDOT's view of the corridor, the DB Contractor shall be subject to the following requirements when providing additional CCTV cameras to TxDOT:

The DB Contractor shall provide CCTV cameras for Incident or Emergency verification and traffic management. The system of cameras shall accurately identify all vehicle(s) involved in an Incident or Emergency, the extent of vehicle(s) damage, and if applicable, the likelihood of personal injury. Operation of the cameras shall result in no visual delay in response of the camera pan/tilt/zoom by a user.

Equipment

The DB Contractor shall provide all necessary CCTV equipment for TxDOT, including cameras, camera controls, cables, and connections compatible with TxDOT's Lonestar system. The DB Contractor shall provide all the equipment necessary for TxDOT's control of all CCTV cameras. The method of control shall be in accordance with TxDOT Engineering Standard Sheets and TxDOT Standard Specifications.

The DB Contractor shall provide a digital video format and communications protocol at all connections with TxDOT systems.

Placement

Spacing between CCTV cameras shall not exceed one mile. The DB Contractor shall provide overlapping roadway coverage by CCTV cameras for all highway lanes and intersecting cross streets within the Project limits in a manner that reflects existing coverage. CCTV cameras shall be placed to monitor traffic conditions on highway lanes, access roads, connecting facilities, entrance and exit ramps, and messages displayed on any remotely-controlled DMS in the Project area. To provide a stable video image, the DB Contractor shall mount all TxDOT cameras on dedicated structures.

The DB Contractor is responsible for placing cameras to ensure 100 percent coverage, defined as no blind spots for any reason, including but not limited to: trees, bridge structures, horizontal or vertical alignment, overhead or side mounted sign structures. Additionally, each CCTV camera shall be able to view the CCTV camera immediately upstream and downstream from itself.

Video Requirements

The DB Contractor shall provide state-of-the-art CCTV cameras for TxDOT that meet the requirements of the applicable TxDOT Engineering Standard Sheets and TxDOT Standard Specifications. If at any time prior to Final Acceptance, any CCTV cameras fail to meet the latest TxDOT Engineering Standard Sheets and TxDOT Standard Specifications in effect at the time of design, the DB Contractor shall replace such cameras within 48 hours of discovery of lack of compliance.

Operating Requirements

The DB Contractor shall provide cameras with built-in heaters, mounting structure, and related equipment capable of operating within the following weather conditions:

- Ambient temperature range of -35 degrees Fahrenheit to +140 degrees Fahrenheit.
- Relative humidity range not to exceed 95 percent within the temperature range of +40 degrees Fahrenheit to +110 degrees Fahrenheit.
- Humidity range of 0 to 100 percent condensing.

Control Requirements

Allow a minimum of 30 days for testing by TxDOT ITS personnel. Submit the CCTV equipment for testing no later than 60 days after completion of TxDOT's Submittal review. The equipment submitted for testing must be fully assembled and in a fully operational condition. Configure all equipment submitted for testing as is intended for use on the Project. Prototype equipment is not permitted. The equipment shall be interconnected to the existing CCTV control system and must be fully operational using that system. No modifications to the existing CCTV control system shall be made to accommodate the submitted CCTV equipment. To be considered fully operational, the equipment must, at a minimum, correctly respond to the following commands:

- Pan left
- Focus far
- Pan right
- Iris override
- Tilt up
- Iris open
- Tilt down
- Iris close
- Zoom in
- Camera power (latching)
- Zoom out

- Pan tilt position preset
- Focus near

Upon completion of installation, the DB Contractor shall test the communications link installed between the satellite building and the CCTV field equipment locations. The DB Contractor shall perform the test at all TxDOT-owned CCTV locations on the Project.

The DB Contractor shall use a test signal generator and a video monitor to demonstrate the ability of the video signal link to transmit a National Television System Committee compliant video signal from the CCTV cabinet to the satellite building. After completion of testing with the signal generator, connect the CCTV camera to the link and use a video monitor at the satellite building to verify the presence of a National Television System Committee compliant video signal. No degradation of the video signal shall be discernible using the video monitor.

As a part of testing, the DB Contractor shall connect a laptop computer containing TxDOT-supplied CCTV control software on the link and use it to demonstrate the ability to control all CCTV functions outlined in the specifications.

The DB Contractor shall supply all test equipment, cabling, and connectors necessary for performing the tests on TxDOT-owned CCTV equipment by the DB Contractor.

The DB Contractor shall be permitted one opportunity to retest equipment which does not pass the initial test. The retest must occur within 30 days after the initial test. All issues of non-compliance and all discrepancies shall be resolved prior to commencing the second test. Equipment which is not able to be retested within 30 days, or which does not pass the second test, shall not be used on the Project. The DB Contractor shall not be entitled to additional time or compensation on account of the testing of the CCTV equipment. Successful testing of the CCTV equipment must be completed prior to any construction activities at the CCTV locations. No camera poles, cabinets, or any other CCTV related equipment shall be installed until CCTV equipment testing is successfully completed.

18.6 Mobility Authority Dynamic Message Signs

The DB Contractor shall be responsible for design and construction of the DMS support systems, including DMS sign foundations, DMS overhead support structure, DMS controller foundation, electrical service, grounding, and conduits for power and communication routed to the DMS sign structure and Duct Bank systems. The DB Contractor shall design and construct the power and communication infrastructure for tolling signs (including single-line DMS panels, also known as “bricks”), at the locations shown on the ITS Schematic. The design shall be accordance with TxDOT *Standard Specifications for Construction and Maintenance of Highways, Streets, and Bridges*, and the Austin District standards. The SI will install the DMS signs, single line DMS panels (i.e. “bricks”), fiber optic cables, and connect the sign to the

communications network. All DMS must be designed and shown in the overall sign design discussed in Technical Provision 13.

The DB Contractor shall verify all proposed DMS locations by a site visit to each proposed location prior to completing the Final Design Plans. The DB Contractor shall provide sufficient conduit to the DMS; communication cable shall not be in the same conduit with power conductors. Verify, avoid or mitigate all conflicts with existing above and underground utilities for sign structure and conduit.

The DB Contractor shall comply with all TMUCD sign spacing requirements. Location of the DMS needs to be reviewed with the permanent signing layout to ensure signs are not obstructing DMS view and to allow for adequate time for appropriate motorist response. All DMS messages shall be within the line of sight of a CCTV for message verification. Locate DMS structures and controller cabinets outside the clear zone or protected from errant vehicles by traffic barrier. Exercise diligence in minimizing roadside obstacles within the clear zone including protective barriers. Locate the DMS controller cabinet approximately 100 feet in front of the visible message area of the sign to facilitate maintenance of the sign.

Final Locations. The final locations of DMS proposed by the SI shall be addressed in the Permanent Signing Concept Report (Technical Provision 13). Adequate sign spacing must be available, or made available, to ensure locations are suitable for DMSs. Adequate spacing will depend on roadway and ramp alignments, ramp spacing, available bridges, and required roadway guide sign spacing.

Safety and Access. The selected locations shall provide reasonable and safe parking and access by service personnel. A paved service bay (safety pullout) shall be provided at locations where access is not deemed adequate by the Mobility Authority or its SI.

Mounting Designs. The DB Contractor shall design any separate sign trusses. All sign designs must incorporate appropriate structure for reasonably convenient and safe access by maintenance personnel from off the roadway, including an access walkway with handrail. Support structures shall be aesthetically treated in accordance with Technical Provision 10. The DB Contractor shall coordinate with the SI when developing the mounting design.

Sign Visibility. DMSs shall be illuminated by light emitting diodes (LEDs), which are directional and provide only a relatively narrow cone of visibility for drivers. The exact sign locations and aiming are very important; each sign must be mounted to maximize the traveling public's ability to view the DMS's message. The DB Contractor shall indicate DMS locations and aiming in the final ITS plans.

18.7 TxDOT Dynamic Message Signs

The DB Contractor is responsible for maintaining TxDOT DMS functionality for the duration of the Project. Should relocation of TxDOT DMS be required as a result of the Project, the DB Contractor shall demonstrate this as a part of the ITS Implementation Plan for review and approval by the Mobility Authority. Relocated TxDOT DMS shall be placed as close as possible to the existing locations. DMS shall

be mounted using a T-mount and located so that main lane closures are not needed to maintain the sign. Sign walkways shall not be installed on any new TxDOT DMS structures. DMS site shall be accessible in all weather conditions. Access pads shall be provided if necessary to support maintenance. The DB Contractor is subject to the requirements of *Technical Provision 18.6* for DMS design. The DB Contractor shall be responsible for relocating or providing replacement cabinets, controllers, cables and connections as needed to maintain TxDOT DMS functionality on the Project.

18.8 Barrier Mounted Gates

The DB Contractor shall procure and install Versilis MASH tested HSG-40CW/22CW vehicle barrier mounted gates or equivalent. The DB Contractor shall design gate locations at each express lane ingress location. The DB Contractor shall coordinate with the SI regarding infrastructure requirements needed to support the gate systems. Gate system conduit shall connect to the Duct Bank.

18.9 Mobility Authority Vehicle Detectors

The DB Contractor shall install foundations, conduits, grounding, vehicle detector support structures, and electrical services for vehicle detectors at the locations specified by the SI. The SI will install the vehicle detectors, communications, and equipment enclosures.

The DB Contractor shall verify all proposed locations by site visit prior to final plan completion. The DB Contractor shall place vehicle detectors in locations generally consistent with the ITS Schematic. The DB Contractor shall ensure vehicle detection locations are selected in such a manner that the equipment will operate and not receive inference from structures or barriers. Final placement of vehicle detection poles shall consider maintenance access. The DB Contractor shall provide sufficient conduit to the vehicle detectors; communication cable shall not be in the same conduit with power conductors. Verify, avoid or mitigate all conflicts with existing above and underground services.

Technical Requirements. The vehicle detectors shall be in accordance with TxDOT *Standard Specifications for Construction and Maintenance of Highways, Streets, and Bridges*, adopted by TxDOT in November 2014 and the Austin District standards.

18.10 TxDOT Vehicle Detectors

The DB Contractor is responsible for providing permanent, high definition microwave radar detection within the limits of the Project for each highway lane that measures vehicle classification, vehicular volume, lane occupancy, and vehicle speed information. The detectors shall be non-intrusive to the roadway users. Spacing for the permanent vehicle detection shall be no greater than one-half mile in each highway lane in the Project, and, at a minimum, provide detection for all highway lanes at one location between interchanges, each entrance ramp lane, and each exit ramp lane. The DB Contractor shall locate the devices on the side of the Project nearest the largest shoulder so as to limit the potential interference by the concrete traffic barrier on detecting vehicles and collecting information.

Vehicle detection sensors shall determine vehicle speed for each vehicle passing the sensor. The sensors shall provide raw speed data (volume, speed, lane occupancy, and vehicle classification counts) and direction of travel for all lanes. Additionally, the sensors (or the software controlling the sensors) shall be capable of determining vehicles traveling in the wrong direction. For sensors that collect data across multiple lanes of traffic, data shall be collected and provided by lane. In areas where a sensor would have to collect data on more than 12 lanes of traffic, including shoulders or over distances/widths greater than 250 feet, the DB Contractor shall provide additional detectors as required. The DB Contractor shall provide detectors that allow TxDOT to adjust the frequency rates that the data files are provided by device.

The DB Contractor shall abandon all existing in-ground loops impacted by the Project as a part of the ITS Implementation Plan. DB Contractor shall attach detection units to existing CCTV poles with prior concurrence from TxDOT. Where an existing structure is not available, or in lieu of attaching the detection unit to an existing structure, the DB Contractor shall install a mounting pole solely for the vehicle detector. Any mounting poles placed specifically for ITS items shall conform to the TxDOT Standard Specifications and Good Industry Practice for vehicle detection mounting poles and must adhere to minimum vertical clearance requirements. The DB Contractor shall provide all necessary support structures and equipment, including, but not limited to, vehicle detection system devices, controls, cables, and connections.

18.11 Roadside Communication Units

The DB Contractor shall install foundations, conduits, grounding, roadside unit (RSU) support structures, and electrical services for roadside units to enable dedicated short-range communications (DSRC), Bluetooth and/or Wi-Fi communications at the locations specified by the Mobility Authority. The SI will install the RSUs, communications, and equipment enclosures.

The DB Contractor shall verify all proposed locations by site visit prior to final plan completion. The DB Contractor shall place RSUs in locations generally consistent with the ITS Schematic. The DB Contractor shall ensure RSU locations are selected in such a manner that the equipment will operate and not receive inference from structures or barriers. Final placement of RSU poles shall consider maintenance access. The DB Contractor shall provide sufficient conduit to the RSUs; communication cable shall not be in the same conduit with power conductors. Verify, avoid or mitigate all conflicts with existing above and underground services.

18.12 Electrical Services

The DB Contractor shall verify all proposed electrical services by a site visit to each proposed location prior to Final Design Plans. The DB Contractor shall verify availability of required supply voltage and load current with the local utility and verify, avoid or mitigate all conflicts with existing above and underground services. Circuits between the electric service panel board and the field device cabinet shall be classed as feeder circuits. Individual electric power circuits inside the field device cabinets and enclosure shall be classed as branch circuits. Calculate all individual circuit load currents based upon information provided and NEC requirements. The DB Contractor shall coordinate with the SI to obtain ITS and Tolling Device

Load information. Branch circuit voltage drop is usually minimal and ampacity calculations should dominate wire size and selection. Feeder Circuits voltage drop should dominate wire size and selection. Feeder Circuits voltage drop shall be less than 5 percent of the nominal line voltage. Conductor ampacity requirements shall be in accordance with NEC requirements.

The DB Contractor shall provide minimum adequate conductor length inclusive of the following:

- Horizontal distance of each conduit and Duct Bank run in the conductor physical path.
- 25 feet for each conductor or cable in Type UCV ground box.
- 6 feet for each conductor or cable in Type D ground box.
- 5 feet vertical rise at service pole, IA cabinet, DMS controller, CCTV, etc.
- Scale factor (nominally 5 percent) for non-linear distance and vertical curves in conduit and Duct Bank system.

18.13 Communication with Traffic Management Center

The DB Contractor infrastructure design shall accommodate communication with the Mobility Authority's Traffic Incident Management Center (TIMC) into the Duct Bank design.

For TxDOT communications infrastructure on the Project, the DB Contractor shall provide a communications network, separate from the Mobility Authority's, that has redundant routing capabilities. The communications network shall serve the highway ITS components along the highway Elements of the Project. Where necessary, as determined by TxDOT, the DB Contractor shall provide ITS communications hubs/cabinets to support the communications network.

18.14 ITS Detailed Requirements

The Mobility Authority expects that the DB Contractor shall design and construct the roadway corridor in phases. However, the Project ITS must be designed as a whole, before installation of any individual field component or fiber segment. This necessitates the early completion of a complete ITS Plan, for submittal to the Mobility Authority for review. To allow for SI implementation and testing, construction of ITS and Duct Bank is subject to the same construction completion milestones as the *Technical Provision 21*.

ITS Plan. The ITS Plan shall include a legend of symbols, 100-scale construction plan sheets showing the location of all ITS components by station and offset, and plan details. For each ITS device location, include a cross section identifying the offsets and mounting height. In addition, the ITS Plan shall include a vertical profile of the Duct Bank. The DB Contractor shall be responsible for ensuring that the Duct Bank does not conflict with other roadway elements.

Plan and Detail Sheets. The construction plan sheets shall show the route of the Duct Bank and the locations of all existing and proposed Mobility Authority and TxDOT ITS devices (CCTV camera

assemblies, DMSs, vehicle detectors, RSUs, control cabinets, sources of power, Hub enclosures, fiber conduit locations, ground boxes, UCVs, junction boxes, handholes, electric service components, etc.). The DB Contractor shall submit a Preliminary (30%) Design Submittal, an Intermediate (65%) Design Submittal, and a Final (100%) Design Submittal for review and approval by the Mobility Authority addressing the ITS infrastructure design requirements.

Component Specifications, Inspection, and Documentation. All ITS materials and components shall conform to pertinent local codes and ordinances; the NEMA standards; the Electronics Industries Association (EIA) standards; the Telecommunications Industries Association standards; and the TxDOT *Standard Specifications for Construction and Maintenance of Highways, Streets, and Bridges*.

Mounting Hardware. Use stainless steel mounting hardware (bolts, nuts, washers, external hinges, etc.) on vaults, cabinets, shelters, handholes, and other outdoor ITS devices.

Ground Boxes – Ground boxes shall be constructed with aprons in all areas other than within sidewalk, paved areas, or riprap.

F&I Components. The DB Contractor shall round and smooth sharp corners and edges of all ITS components that are furnished and installed.

Aboveground and Exposed Field Devices. The DB Contractor shall verify all proposed above ground and exposed field devices by site visit prior to Final Design Plans completion. Verify, avoid or mitigate all conflicts with existing above and underground utilities.

This section describes the requirements to ensure electrical safety in the vicinity of overhead power distribution and transmission lines. Items included in this section are, but not limited to, all above ground field devices including DMS installations, CCTV installations, and hub enclosures. Exposed items are those devices, enclosures, ground boxes, cabinets, poles that are in the transmission line ROW clear zone and may be exposed to significant voltages and pose an electrocution hazard to pedestrian or other personnel.

Where overhead transmission voltages exceed 34.5 KV, all items shall be located horizontally such that they are clear of the transmission line ROW zone recommendations contained in the *USDA Rural Electrification Administration Bulletin 1724E-200, Chapter 5, Horizontal Clearance from Line Conductors to Objects and Right-of-Way Width*.

Where overhead distribution voltages are less than 34.5KV all items shall be located horizontally such that they are clear of the transmission line ROW clear zone recommendations contained in the *USDA Rural Electrification Administration Bulletin 1724E-200, Chapter 5, Horizontal Clearance from Line Conductors to Objects and Right-of-Way*. Where it is not feasible to maintain horizontal clearance from the ROW zone, the vertical clear zone for voltages greater than 34.5 KV, with pedestrian access shall be used. Distances shall be calculated from the nearest phase conductor to the highest and nearest point on the field device.

Power Service Costs. During the Project, the DB Contractor shall pay all costs charged by the electric power companies for providing power connections for all ITS devices. The DB Contractor shall pay the monthly electrical bills until 120 days after Substantial Completion of the Project. 120 days after Substantial Completion, the DB Contractor shall transfer billings for TxDOT-owned ITS devices to TxDOT, and ITS devices owned by the Mobility Authority to the Mobility Authority.

References

- Standard Specifications for Structural Supports for Highway Signs, Luminaries and Traffic Signals – AASHTO.
- National Electrical Safety Code.
- National Electric Code.
- Regional ITS Architecture and Deployment Plan Austin District, latest edition.

18.14.1 TxDOT Equipment/Systems

Consistent with TxDOT Special Provision 002-007, the DB Contractor shall be Technically Qualified in all ITS Work Categories to perform the following on the Project for any elements owned by TxDOT:

- Pulling Fiber Optic Cable.
- Splicing and Testing Fiber Optic Cable.
- System Integration.
- DMS Installation.
- CCTV Camera and Equipment Installation.
- Wireless Communications.
- Radar Detection Systems.

Acceptance Testing

For each component of the relocated ITS, the DB Contractor shall prepare an ATP to be submitted to the Mobility Authority at Intermediate (65%) Design to assure proper operation, control, and response of each device meeting the functional requirements. The DB Contractor shall implement the ATPs and provide certified documentation that its requirements have been met prior to operational use of the ITS.

As part of the ATP, the DB Contractor shall prepare a system acceptance procedure prior to start of construction to assure proper operation, control, and response of each device as part of the overall ITS,

including the overall operating system and software. The DB Contractor shall conduct the procedure and provide certification that the ITS effectively meets the required functional requirements. The DB Contractor shall submit this certification to the Mobility Authority prior to Substantial Completion or the DB Contractor's request for an incentive-related payment, whichever occurs first.

End-to-End Testing

For all relocated TxDOT ITS, the DB Contractor shall provide notice and coordinate with the Mobility Authority to allow for end-to-end testing of the ITS. The DB Contractor shall not commence end-to-end testing until the following conditions have been met: the DB Contractor and TxDOT shall have successfully completed all their testing; the DB Contractor has completed training of all relevant TxDOT staff; and the DB Contractor has met all acceptance requirements for the DB Contractor installed ITS devices, satellite buildings, communication and electrical networks, and generators.

The DB Contractor shall be responsible, at a minimum, for the following:

- Coordinating the end-to-end testing with the Mobility Authority to ensure that there are no conflicts between the Mobility Authority, TxDOT, their affiliated contractors, and the DB Contractor's staff.
- Providing temporary advance signing (if needed) stating that the facility is closed and testing is occurring.
- Providing MOT/traffic control at all necessary locations for a maximum of five (5) full days, which could include evenings and weekends and are not required to be consecutive.
- Providing access to the facility for authorized Mobility Authority and/or TxDOT staff and contractors.
- Repairing any issues found with the DB Contractor's work within one (1) day unless otherwise approved by the Mobility Authority.

The DB Contractor shall not expect to have access to, nor conduct work within, the Project during the end-to-end testing, with the exception of providing the services as described above. The Mobility Authority may, at its own discretion, provide the DB Contractor access to the Project to conduct work outside the services described above.

Record Documents

The Record Documents shall include the construction drawings, as well as catalog sheets for all equipment and components. The DB Contractor shall maintain for the Term records of all updates and modifications to the system.

For each component of the ITS, all computer codes and software shall be available to the Mobility Authority.

18.14.2 Inductive Detection Loops

The DB Contractor shall abandon all existing in-ground loops impacted by the Project as a part of the ITS Implementation Plan.

18.14.3 License Plate Recognition System

The DB Contractor shall be responsible for design and construction of the support structures for the License Plate Recognition (LPR) system assemblies associated with toll systems equipment. The LPR cameras shall be mounted by the SI on toll gantries, complying with the manufacturer's recommendations for installation. The work includes all pull boxes and conduits for power and communication routed to the camera assemblies.

18.14.4 Equipment Cabinet

The DB Contractor shall be responsible for design and construction of the pull boxes and conduits for power and communication routed to the equipment cabinets.

18.14.5 Plan and Detail Sheets

The construction plan sheets shall show the route of the electrical and communications conduits and the proposed approximate locations of all devices.

18.14.6 Mounting Hardware

Use stainless steel mounting hardware (bolts, nuts, washers, external hinges, etc.) on vaults, cabinets, shelters, handholes, and other outdoor virtual weigh station components.

18.15 Submittals

Table 18-1: Submittals to Mobility Authority

Submittals	Submittal Schedule	Mobility Authority Action	Reference Section
ITS Implementation Plan	Intermediate Design Submittal	Approval	18.2
ITS Infrastructure Design	1. Preliminary (30%) Design Submittal, 2. Intermediate (65%) Design Submittal, 3. Final (100%) Design Submittal	Review and Acceptance	18.14
ITS Plan	Before installation of any individual field component or fiber segment	Review	18.14
ATP	Intermediate Design Submittal	Review	18.14.1
Certification	Prior to Substantial Completion or the DB Contractor's request for an incentive-related payment, whichever occurs first	Review and Acceptance	18.14.1

19.0 LIGHTING

The DB Contractor shall be responsible for providing continuous illumination and safety illumination in accordance with the requirements identified in this *Technical Provision 19*.

19.1 Referenced Manuals, Standards, and Guidelines

The DB Contractor shall conform to the latest requirements of the following standards and guidelines in designing and constructing the lighting system.

- AASHTO *Roadway Lighting Design Guide*
- AASHTO *A Policy on Geometric Design of Highways and Streets*
- AASHTO *LRFD Specifications for Structural Supports for Highway Signs, Luminaires, and Traffic Signals*
- Illuminating Engineering Society of North America (IESNA), Reference and Application (HB-10)
- IESNA Recommended Practices for Roadway Lighting (RP-8-18) and other IESNA publications. TxDOT Highway Illumination Manual (HIM)
- Texas Manual on Uniform Traffic Control Devices (TMUTCD)
- TxDOT *Roadway Design Manual*
- TxDOT *Standard Specifications for Construction and Maintenance of Highways, Streets, and Bridges, adopted by the TxDOT*
- TXDOT *Traffic Operations Standard Plan Sheets*
- National Fire Protection Agency (NFPA), National Electrical Code (NEC)
- Title 43, Texas Administrative Code, Section 25.11, *Continuous and Safety Lighting Systems*
- Texas Health and Safety Code, Chapter 425, *Regulation of Certain Outdoor Lighting*
- Underwriter's Laboratories and NEMA electrical standards

19.2 Lighting Requirements

Design Requirements. The DB Contractor shall determine the required lighting types in accordance with the requirements of this *Technical Provision 19*, and apply the appropriate IESNA, TxDOT, AASHTO, and NEC design standards.

The DB Contractor shall provide continuous illumination, utilizing high mast lighting along the US-183 corridor. High mast lighting is not required along Loop One (MoPac) and conventional lighting can be used. Existing conventional lighting shall be removed. New conventional lighting shall only be used at

locations such as entrance and exit ramps where high mast lighting cannot provide the required photometric coverage or there are FAA height restrictions. Conventional lighting shall be used on cross streets.

All third-party requests for lighting within the Site shall be subject to the Mobility Authority approval.

The DB Contractor shall design continuous lighting systems, including safety lighting where warranted, in accordance with the TxDOT *Highway Illumination Manual*. All design and construction shall comply with the latest TxDOT Engineering Standard Sheets and TxDOT Standard Specifications. At all times during the Term of the DBA, the DB Contractor shall maintain safe and continuous lighting conditions along the Project roadway.

Conventional luminaire poles and breakaway bases shall be designed in accordance with AASHTO Standard Specifications for Structural Supports for Highway Signs, Luminaires, and Traffic Signals. For all poles located within the clear zone of the roadways, the DB Contractor's design shall incorporate breakaway devices that are pre-qualified by the Mobility Authority. Any high mast lighting poles shall meet the requirements of TxDOT Engineering Standard Sheets and TxDOT Standard Specifications.

The DB Contractor shall determine and design appropriate foundation types and lengths for permanent lighting structures.

The DB Contractor shall provide to the Mobility Authority an Acceptance Test Plan (ATP) for all illumination. This ATP shall also be submitted to the appropriate Governmental Entity. The DB Contractor shall conduct testing in accordance with the ATP and document those results to show conformance.

19.2.1 Permanent Lighting

Illumination Requirement. When required, the Mobility Authority's goal is to provide an average illuminance level of between 0.6- and 0.9-foot candles on the traveled lanes. Illumination uniformity shall comply with the AASHTO Roadway Illumination Design Guide requirements. Lighting requirements for sidewalks, shared use path and intersections are specified in *Technical Provision 10*.

DB Contractor Responsibilities. The DB Contractor shall provide lighting designs to meet criteria listed in Table 3-5a of the AASHTO *Roadway Lighting Design Guide* on all traveled roadways to be illuminated. Traveled roadways include: general purpose lanes, express lanes, direct connectors, interchanges, ramps, ramp terminals at frontage roads, frontage road intersections with cross streets and underpass lighting. Frontage roads are not required to be illuminated as part of this Project.

The specific Work shall include:

- The DB Contractor shall provide electrical layout, including circuit loading and voltage drop calculations.
- Developing lighting design plans for and constructing new roadway lighting, complete with concrete foundations, fixtures, light poles, conduits, wiring, and electrical service.
- Provision of intersection lighting as part of any new required signal system installations.

LED Lighting. LED fixtures that conform to TxDOT DMS 11011 shall be used at all proposed conventional lighting locations. LED fixtures that conform to TxDOT special specification 6156 shall be used at all proposed high mast lighting locations. The DB Contractor shall provide LED fixtures for high mast lighting and LED fixtures for conventional roadway lighting and under bridges at underpass/overpass locations throughout the Project. All existing non-LED fixtures along US-183 corridor within the project limits shall be replaced with LED fixtures.

Lighting Under Structures. Underpass lighting fixtures, currently listed on the TxDOT Material Producer List shall be used underneath all cross-over and underpass bridges. Underpass lighting shall be limited to locations with existing underpass lighting or to locations with new structures (or widened structures) greater than or equal to 70 feet in width. All existing HPS underpass fixtures shall be replaced with new LED fixtures. The DB contractor to move or add additional fixtures to meet the AASHTO Roadway Illumination Design Guide requirements. The following structures have been identified as locations that shall require underpass lighting along US 183 and Loop 1: Lakeline Mall Dr, Research Blvd/ Ranch Rd, Pecan Park Blvd, Lake Creek Pkwy, Anderson Mill Rd, Pond Springs Rd, Spicewood Springs Rd/ McNeil Dr, Oak Knoll Dr, Duval Rd, Balcones Woods Dr, Baker Ln, Great Hills Trail, Capital of Texas Hwy, Loop 1, Steck Ave, Anderson Ln/ Spicewood Springs Rd and Far West Blvd. Daytime illumination of underpass structures is not required.

The DB Contractor shall place all understructure lighting in a configuration that minimizes the need for Lane Closures during maintenance.

Spillover Light. The DB Contractor shall design the lighting, through light sensitive developments such as residential areas, and apartment complexes etc. within entire Project limits to control light trespass outside the Project ROW and onto the adjacent properties using either cut-off shields or LED Neighborhood Friendly (NF Fixtures) with tightly-controlled photometrics, combined with appropriate mounting height. The DB Contractor shall submit a lighting plan and light spillage photometric contours for the entire Project limits to the Mobility Authority for review and approval as part of the Final Design submittal. NF fixtures shall meet TxDOT Special Specification 6111, LED Neighborhood Friendly High Mast (NFHM) Illumination Assemblies spill light requirements.

Required Equipment. All equipment shall be new and not reused. The following equipment shall be used for permanent lighting, except in locations where high mast lighting is required or where the overhead lighting is provided as part of the signal system:

- Light Pole with Transformer Base.
- Light Fixture.
- Nonmetallic conduit under roadways.
- Electrical Service Cabinet.
- Equipment Pad.

- Underpass Light Fixture.
 - At locations where the overhead lighting is installed as part of a new signal system installation, pole and luminaire materials that are similar to and approved for the other new roadway lighting shall be used.

Specific Requirements: The following are required in designing the permanent lighting:

- Permanent lighting systems should be 480 volt for high mast lighting. Conventional and underpass lighting shall be 240 volt.
- Consider the locations of nearby guardrail, sound walls, retaining walls, utilities, and overhead power lines when placing light poles.
- All light poles within the clear zone must be breakaway or crash-protected. Breakaway light poles shall meet the requirements of the TxDOT *Highway Illumination Manual*.
- The DB Contractor shall determine and design appropriate foundation types and lengths for permanent lighting structures.
- The DB Contractor shall not place ITS cables, fiber-optic lines, traffic signal conductors, or any other non-lighting related cables or conductors in the lighting conduit, ground boxes, or junction boxes.
- The DB Contractor shall minimize the potential hazards of lighting poles through the careful consideration of mounting options and pole placements, including the following options:
 - Placing luminaire mast arms on traffic signal poles.
 - Placing pole bases on existing or proposed concrete traffic barrier.
 - Placing poles behind existing or proposed concrete traffic barrier or metal beam fence.
 - Placing high mast lighting outside the clear zone, especially in roadway horizontal curves.
- A maximum of four different illumination pole height/arm length assembly combinations shall be used. The DB contractor shall justify and obtain approval for additional pole height/arm length assembly combinations.
- All conventional illumination pole bases shall be interchangeable.
- ***Power Service Costs.*** At Project commencement the DB Contractor shall transfer electrical services to TxDOT. The DB Contractor shall pay all costs charged by the electric power companies for providing power connections. The DB Contractor shall be responsible for the development and execution of any permits and agreements necessary for the design and construction of the illumination system. TxDOT shall pay the monthly illumination electrical bills and the DB Contractor to provide maintenance for special and/or temporary lighting installed under the DB Agreement. The DB Contractor shall also maintain the permanent lighting installations, both existing and new, until Final Acceptance (FA) of the Project.

High Mast Lighting. The DB Contractor shall continue operating existing high mast lighting for the duration of the Project.

Ground Boxes. Ground boxes shall be constructed with aprons in all areas other than within sidewalk, paved areas, or riprap.

Frontage Roads. Frontage roads are not required to be illuminated as part of this Project but the contractor shall maintain existing illumination levels and services along the Frontage Road.

Salvage and Removals. The DB Contractor shall be responsible for disposal of removed lighting units- no salvage and stockpile location will be provided for this Project. The DB Contractor shall also remove and dispose of transformer bases as part of the Work.

19.2.2 Temporary Lighting

DB Contractor Responsibilities. The DB Contractor is required to:

- Provide approach to maintaining illumination during construction in the MOT plan for Mobility Authority approval. The DB Contractor shall coordinate with the Utility Owner(s) and ensure power service is initiated and maintained for permanent lighting systems. Where the Work impacts existing lighting, the DB Contractor shall maintain continuous existing lighting as temporary lighting during construction and restore or replace prior to Substantial Completion of the Segment. At all times during the Term of the Agreement, safe continuous lighting conditions shall be maintained along the Project roadway. The contractor may install permanent high mast lighting system on the outside and use it as temporary lighting during construction. The DB Contractor can use timber poles for temporary installations only.
- Maintain current levels of roadway illumination on general purpose lanes, ramp or interchange areas for the duration of the Project.
- Design temporary lighting plans, as needed.
- Furnish and install temporary lighting equipment for the roadway and interchanges as necessary.
- Provide all materials and equipment for temporary lighting installations.
- In the clear zone, provide only lighting units that are breakaway or protected from crash potential.

19.3 Lighting Aesthetic Requirements

The DB Contractor shall comply with the following requirements:

LED strip lighting shall be installed within the art installation under Pond Springs Road underpass structure. Pedestrian lighting shall meet the following requirements:

- Below bridges: shall maintain a 2 fc average throughout the shared use path when the path is below existing and proposed bridges and shall use conventional TxDOT underpass fixtures to meet this requirement.
- Shared use path crossings: shall be illuminated using TxDOT conventional poles at the frontage road crossings for minimum of 100 feet upstream of the intersection.

Table 19-1: LED strip lighting shall meet the following requirements

TYPE	LED STRIP LIGHTING
DESCRIPTION	Surface mounted nominal 1.5 inch round LED strip lighting with sealed optical assembly and stainless steel housing; remote 240V required. Fixture to meet all local code requirements.
HOUSING	Formed stainless steel housing with welded and blended joints and bonded stainless steel end caps.
LENS	Sealed optical assembly.
FINISH	Stainless steel: Satin
LIGHT SOURCE	ITL tested in accordance with IESNA LM-80. Minimum 50,000 hour rated life at 70% of initial lumens. Color temperature: 3000K. CRI: Equal to or exceeding RA>80.
REFLECTOR	N/A
DRIVER	96W Driver with integral dimming, 100-277VAC, 47/63 Hz, 24V DC output and open circuit, short circuit, overload and overheating protection.
VOLTAGE	240 VAC
MOUNTING	Refer to Design Guidelines.
RATINGS	UL Listed for wet locations. ADAAG (Americans with Disability Act Accessibility Guidelines), ANSI and ADA compliant. Rated IP67.
WARRANTY	Equal to or exceeding 3 years.
OPERATING TEMPERATURES	Suitable for use in ambient temperatures up to 50°C (122°F).
POWER SUPPLY	240 Watt 24 VDC Waterproof Power Supply with PFC

19.4 Lighting Roll Plot

The DB Contractor shall prepare a lighting roll plot for all new and impacted lighting that shall consider illumination levels, uniformity and sources in accordance with the TxDOT HIM that includes:

- The existing levels of illumination in the Project corridor.
- The existing amount of spillover lighting outside the Final ROW.
- The levels of illumination required for the Project, based on current TxDOT Standards.
- The levels of illumination required for sidewalks and shared use paths.

The lighting roll plot shall:

- Show all proposed permanent lighting locations and designs.
- Conform to any requirements set forth in the Environmental Documents.

Submittal. The DB Contractor shall submit the lighting roll plot to the Mobility Authority as a part of the Formal Design Review. Prior to beginning any permanent lighting Design Work, the DB Contractor shall resolve all comments on the lighting study to the satisfaction of the Mobility Authority. The lighting study shall include a computer model of the lighting levels which includes all photometric calculations of lighting levels, maximum, minimum, average, and average to minimum ratio over the areas of interest, including light spill over. The DB Contractor shall submit the photometric data results for all lighted areas within the Project limits to the Mobility Authority for review and acceptance as part of the 30% and Final Design submittal. The submittal shall include all input data including fixture models.

19.5 Lighting Plans

Submittal. The DB Contractor shall submit the permanent lighting plans to the Mobility Authority.

Plan Certification. All temporary lighting and permanent lighting final plan sheets must be signed and certified by a Registered Professional Engineer.

Plan Format. The lighting plans shall include appropriate signature lines, roadway design values, legends and symbols, a list of scales, and a plan index.

Plan Items. The lighting plans, at a minimum, must show the following:

- General Notes requiring the use of TxDOT prequalified lighting fixtures and lamps.
- General Notes requiring the use of lighting poles as specified in the plans, including foundation bases and anchorages.
- General Notes requiring the use of TxDOT prequalified and UL listed service equipment, including photocells.
- General Notes requiring the use of TxDOT prequalified and UL listed conductors, conduit, ground boxes, and terminations that are needed for the complete operation of the lighting system.
- Special Provision for licensed electrician requiring compliance with Item 18.1.4 of the TxDOT *Standard Specifications for Construction and Maintenance of Highways, Streets, and Bridges*. The special provision shall require a licensed electrician to directly supervise all electrical Work.
- General Notes requiring the use of TxDOT prequalified and UL-listed handholes, and junction boxes required for the installation.
- General Notes requiring Streetlight grounding according to TxDOT Standards and Specifications.

Plan Contents. The lighting plans shall include:

- Design drawings showing type and location of all existing illumination that is either to remain, be removed, or be replaced.
- Provisions for conduit, handholes, and junction boxes.

- Detail sheets showing pole details for each type of pole used in the Project, details for mounting the service panels and photo-electric controls, and any special anchorage details.
- Layout sheets showing the location of the roadway (including the clear zone) relative to the locations of light standards, cable, service panels, conduit, junction boxes, and pull boxes.
- Proper labeling and identification of all of the above items, and tabulations listing the stations, locations, and types of lighting units.
- Wiring diagrams to detail the wiring of the lighting circuits and to show wire sizes.
- Applicable TxDOT standard details.
- Final lighting photometric and footprints, including all calculations of lighting levels, maximum, minimum, average lighting levels, and average to minimum ratio over the areas of interest, including light spill over.
- Electrical circuit calculations including all: service loads for service conductors, main circuit breaker, contactor, control circuits: feeder circuit conductors, circuit breakers, conduit fill and ampacity reduction factors, ampacity and voltage drop calculations, and branch circuit calculations.
- Mobility Authority illumination shall be metered separately from TxDOT illumination. In general, operation and maintenance of general purpose lanes, express lanes, ramp, ramp gore, and underdeck lighting are the responsibility of the Mobility Authority. Operation and maintenance of frontage road and intersection lighting is the responsibility of City of Austin.
- Electrical service summary sheet as required by TxDOT for illumination plans.

19.6 Project Records

Project Records. The DB Contractor shall retain the following information and submit it to the Mobility Authority at Final Acceptance (FA):

- Lighting design plans.
- Record Drawings.
- Permits.
- Inspection reports, including an electrical inspection by competent and qualified inspection authority reviewed by competent engineering authority.
- A certificate of compliance with specifications and detailed shop drawings.

Shop Drawings and Product Data. The DB Contractor shall have readily available for Mobility Authority inspection all shop drawings and product data for the following items:

- Poles, bases, anchor bolts, and mast arms, for each type and size including mill certifications and certification of AASHTO compliance for breakaway poles.

- Manufacturer’s photometric performance, part number, special instructions for LED fixtures.

Additional requirements are as follows:

- At a minimum, underground conduit in interchange areas or temporary detours shall not be less than two inches or Schedule 40 PVC; all other underground conduit installations shall not be less than two inches or Schedule 40 PVC.
- The minimum conductor size shall be 12 AWG copper. When selecting conductor size the DB Contractor shall also ensure that TxDOT/NEC voltage drop and ampacity requirements are satisfied with regard to load and breaker size. The DB Contractor shall not use duct cable for illumination purposes.
- Ground box covers shall be non-conducting material and labeled “Danger High Voltage Illumination”.
- Lights shall have an identification tag denoting a contact person or office in case of Emergency or for maintenance, and the address and telephone number.
- Electrical part of the installation shall be designed and installed in conformance with the NEC, TxDOT standards and Specifications.
- The DB Contractor shall not use timber poles for permanent installation.
- The DB Contractor shall re-sod or re-seed areas of construction disturbed by the installation of the lighting systems after final installation.
- The DB Contractor shall remove all old illumination-related cable and conduit that does not have existing pavement or riprap above it; any existing illumination-related conduit that is under the existing pavement or riprap may be abandoned. Existing conductors shall be removed.
- The DB Contractor shall contact Utility Owners regarding their specific required working clearance requirements.
- The DB Contractor shall affix an identification decal on each electrical service indicating service address as well as all required information shown on the Electrical Detail (ED) standard sheets.

19.7 Submittals

Table 19-2: Submittals to Mobility Authority

Submittals	Submittal Schedule	Mobility Authority Action	Reference Section
Lighting Roll Plot	As part of the Formal Design Review	Acceptance	19.4
Photometric Data Results	30% Design and Final Design	Review and Acceptance	19.4
Permanent Lighting Plans	Before any permanent lighting construction	Acceptance	19.5
Record Drawings, Permits & Inspection Report	At Final Acceptance	Information	19.6
ATP for all illumination	As part of the Final (100%) Design Submittal	Review and Comment	19.2

20.0 PAVEMENT

20.1 General Requirements

The Mobility Authority has provided the minimum pavement design for the Project in this *Technical Provision 20*. The Pavement Design Report for the Project is provided for information in *Exhibit D – Item 3 – Technical (Pavement)*. The DB Contractor shall not be required to provide a pavement design report for the Project permanent pavement or the transition pavement. As a part of the Formal Design Reviews, the DB Contractor shall submit signed and sealed pavement designs for temporary pavements required for DB Contractor’s traffic control plans and detours.

For maintenance requirements during construction, see *Technical Provision 24*.

20.2 Pavement Materials and Construction Requirements

20.2.1 Express and General Purpose Lane Widening Pavement and Structural Section Requirements

Express and General purpose lane Widening Pavement. Express and General purpose lane widening pavement shall be Continuous Reinforced Concrete Pavement (CRCP) in accordance with TxDOT Standards except as specified at Toll Gantries. The pavement section shall be adjusted so as to not block drainage flow as long as the minimum depth of each layer is satisfied. The DB Contractor shall cut the existing pavement back a minimum of 8 inches so as to expose competent material along the new longitudinal joint prior to installing tie bars for the new pavement. The DB Contractor shall repair concrete damaged as a result of tie bar installation. The required pavement section is provided in **Table 20-1**. Due to reconfiguration of existing lanes, longitudinal joints will be located within lanes. This is permissible for existing joints with at least one side of the joint against existing pavement. This does not apply to longitudinal joints on bridge structures, which shall be governed by *Technical Provision 12*. The DB Contractor shall prepare separate CRCP joint plans depicting proposed longitudinal joints. Plans shall include transverse joints at ramp gore areas and other similar critical locations such as at proposed pavement transitions.

Toll Gantries – General purpose lane and Ramp. Pavement at the toll gantry locations shall be Jointed Concrete Pavement using Glass Fiber Reinforced Polymer Bars (JCPGFRPB) in accordance with the Jointed Concrete Pavement Using Fiber Reinforced Polymer Bars Detail on the Mobility Authority’s Concrete Paving Standard provided in *Exhibit D – Item 3 – Technical (Tolling)*. Pavement at toll gantry locations shall be constructed with the same concrete mix design and pavement section thicknesses as the adjacent CRCP. Limits of JCPGFRPB shall be as shown in the Mobility Authority’s *Fixed Price Tolling Standards* provided in *Exhibit D – Item 3 – Technical (Tolling)*. Terminal anchor joints for toll gantry

locations shall be in accordance with the TxDOT Austin District Standard for Jointed Concrete Pavement provided in Exhibit D – Item 3 – Technical (Tolling).

No steel will be allowed in the toll gantry pavement section. The DB Contractor shall coordinate with the System Integrator (SI) to ensure Automatic Vehicle Identification (AVI) equipment operates and functions properly.

Joint Layout. Joint details not covered in a TxDOT Standard sheet shall be the responsibility of the DB Contractor to provide and shall be subject to the Formal Design Review process. The joint layout for all concrete pavement, regardless of type, shall be subject to the Formal Design Review process.

Ramps. Pavement for all ramps shall be the same section (materials and depths) as the adjacent general purpose lane roadway pavement. The end of the ramp shall be defined by a line perpendicular to traffic flow direction located at the end of the physical gore.

Shoulders. Pavement for the shoulders of all roadways shall be the same section (materials and depths) as the adjacent express lane or general purpose lane roadway pavement.

Express lanes, general purpose lanes and toll gantry, shall , at a minimum, be placed with the pavement and structural sections defined in **Table 20-1**. The pavement thicknesses shown in **Table 20-1** are minimum thicknesses. Actual pavement thicknesses shall meet or exceed the values shown in **Table 20-1**.

**Table 20-1:
Minimum Pavement and Structural Section for Express Lanes, General purpose lanes and Toll Gentries**

Material Description	Section Thickness (in.)	TxDOT Specification
CRCP or JCPGFRPB (in.)	11	Item 360
D-GR HMA Ty B (in.)	6	Item 341
TY C1 Select fill (in.)	12	Item 132

Select Fill TY(C1). See Technical Provision 20.2.6 for details.

20.2.2 Loop 1 Express Lane and General Purpose Lane Widening and Structural Section Requirements

Loop 1 express lane and general purpose lane widening pavements shall be constructed with the same section (materials and depths) as the adjacent general purpose lane pavement. The pavement shall be flexible pavement and shall, at a minimum, be placed with the section defined in **Table 20-2**.

Table 20-2:

Minimum Pavement and Structural Section for Loop 1 Express Lane and General Purpose Lane Widening

Description	Inch	TxDOT Specification
PFC	1.5	Item 347
Underseal	N/A	SS3085
D-GR HMA Ty D	2	Item 341
D-GR HMA Ty B	8	Item 341
Prime Coat	N/A	Item 310
FL BS (TY A, GR 5)	10	Item 247
TY C1 Select fill	8	Item 132

20.2.3 Frontage Road Pavement and Structural Section Requirements

The southbound frontage road from Station 101+25 to 112+00 and approximately Station 201+00 to 211+00 shall be reconstructed. The re-constructed pavement shall be flexible pavement and shall, at a minimum, be placed with the section defined in **Table 20-3a** and **Table 20-3b**. US 183 Frontage Road pavement within the project limits shall be edge milled to a depth of 1 inch and overlaid with a Thin Overlay Mixture. Milling shall be in accordance with TxDOT Item 354. The Frontage Road Overlay Pavement Section is defined in **Table 20-3c**.

Table 20-3a:

Minimum Pavement and Structural Section for US 183 Frontage Road Pavement Station 101+25 to 112+00

Description	Inch	TxDOT Specification
D-GR HMA Ty D	2	Item 341
D-GR HMA Ty B	5	Item 341
FL BS (TYD GR5)	8	Item 247

Table 20-3b:

Minimum Pavement and Structural Section for Frontage Road Pavement Station 201+00 to 211+00

Description	Inch	TxDOT Specification
D-GR HMA Ty D	2	Item 341
D-GR HMA Ty B	9	Item 341

Table 20-3c:

Frontage Road Overlay Pavement Section

Description	Inch	TxDOT Specification
TOM Ty C (PG 76-2, SAC-B)	1	Item 347
Bonding Course	N/A	Special Specification 3084

20.2.4 Loop 1 Frontage Road Widening and Structural Section Requirements

Loop 1 frontage road widening pavements shall be constructed with the same section (materials and depths) as the adjacent frontage road pavement. The pavement shall be flexible pavement and shall, at a minimum, be placed with the section defined in **Table 20-4**.

Table 20-4: Minimum Pavement and Structural Section for Loop 1 Frontage Road Widening

Description	Inch	TxDOT Specification
D-GR HMA Ty D	2	Item 341
D-GR HMA Ty C	2	Item 341
FL BS (TYD GR5)	10	Item 247

20.2.5 Shared Use Path Pavement and Structural Section Requirements

Shared use path pavement shall be concrete pavement and shall, at a minimum, be placed with the section defined in **Table 20-5**. Construction joints at a maximum spacing of 40 feet, consisting of 24-inch #4 smooth dowels, shall be provided.

Table 20-5: Minimum Pavement and Structural Section for Shared Use Path

Pavement	Reinforced Class A Concrete – 6”
Reinforcement	6” x 6”- W5 x W5 Welded Wire Mesh Sheets
Select Fill	Select Fill TY C1 – 6”
Expansion Joints	Every 40 LF - Use Preformed ¾” Fiber Expansion Joint Material (Ty 7) in accordance with DMS 6310
Control Joints	Sawcut control joints 1-1/4” deep every 10 LF. Tooled control joints are not allowed.

Note: For locations where the shared use path crosses driveways, a driveway design section shall be used.

20.2.6 Subgrade

Potential Vertical Rise (PVR). New pavement (widening and reconstruction) on this Project shall not be subject to PVR requirements.

Sulfates and Organics. If lime or cement treatment of subgrade is proposed, the DB Contractor shall develop a sulfate and organic protocol for the Mobility Authority's review and comment. The DB Contractor shall resolve all comments to the Mobility Authority's satisfaction prior to starting subgrade preparation. At a minimum the protocol shall include the following:

The DB Contractor shall analyze subgrade material composition and perform necessary construction procedures to preclude soluble sulfate induced heave. The DB Contractor shall take soil samples for sulfate testing every 500 feet of each roadbed (northbound general purpose lanes, northbound general purpose lanes, southbound general purpose lanes, and southbound general purpose lanes) on alternating sides of the road bed taken at 1-foot intervals to a depth of at least 5 feet below the top of finished pavement. If material is taken from a borrow source, samples shall be taken at the borrow source with frequency equivalent to the in situ testing. Sample frequency for a borrow source must be submitted and approved by the Mobility Authority prior to the commencement of hauling from that borrow source. If soluble sulfate content is greater than 3,000 parts per million, the DB Contractor shall implement a procedure to mitigate the high sulfate subgrade. In situ materials which meet PI requirements but have high sulfates (>3,000 ppm) may be used in embankments at locations greater than 48 inches from top of pavement and have no available source of free lime or Portland cement. The DB Contractor shall be solely responsible for all activities and analysis to preclude sulfate reactivity on the Project.

Site Preparation To prepare for construction of the proposed facility, all topsoil, vegetation, roots, and any soft soils in the pavement area shall be stripped from the site and either properly disposed of or stockpiled for later use in landscaping.

Proof Roll Verification. All areas beneath the widened roadway shall be proof rolled to identify loose or soft soils. After stripping and excavating where required, but prior to beginning embankment operations, the pavement area shall be proof rolled with a heavy, loaded pneumatic-tired vehicle such as a 25-ton roller meeting TxDOT Item 216. All proof rolling activities shall be witnessed by the Mobility Authority and shall be performed during a period of dry weather. Any weak areas which yield under proof roll, or any areas with a tendency to pump, shall be mitigated. Such mitigation may include:

- Over excavation and backfilling.
- Reprocessing to remove moisture.
- Installation of geosynthetics.
- Use of underdrains.

In the event such mitigation is required, the Senior Geotechnical Engineer shall be contacted to design an appropriate mitigation procedure. The mitigation procedure shall be submitted for Mobility Authority's review and comment. The DB Contractor shall resolve all comments to the Mobility Authority's satisfaction prior to implementing the mitigation procedure. For certain mitigation procedures, a proof roll and moisture-density control shall be utilized to ensure subgrade stability.

Scarification. After stripping, excavating where required, and proof rolling but prior to placing fill, the exposed soils shall be scarified as per Item 132 of the TxDOT *Standard Specifications for Construction and Maintenance of Highways, Streets, and Bridges*, adopted by TxDOT in November 2014.

20.2.7 Embankment

Select Fill – Embankment Item 132 (TY C1). Materials directly beneath the pavement section to depths specified in the applicable pavement section shall meet the requirements as described in this section. Existing in situ material may be used as Embankment Item 132(TY C1) if the in-situ material meet the requirements of this section. Embankment Item 132(TY C1) shall only be placed after the underlying subgrade has been prepared, inspected, and accepted. Embankment Item 132(TY C1) shall be constructed in lifts no greater than 6 inches compacted.

Embankment Item 132 (TY C1) shall have the following characteristics:

- Materials in accordance with **Table 20-6**.
- Free of organic or other deleterious materials.

Table 20-6: Material Requirements for Select Fill

Item	Description	Percent Retained - Sieve					LL	PI	PI
		1 3/4"	7/8"	3/8"	#4	#40	Max	Max	Min
132	Embankment (ORD COMP) (TY C1)	0-10	-	-	45-75	60-85	45	20	6

Embankment – Embankment Item 132 (TY B). All TY B embankment material *shall have a maximum PI of 25*.

Random Sample for Material Properties. The DB Contractor shall sample and test each select fill material to obtain gradation, Liquid Limit, Plastic Limit, and Plasticity Index in accordance with Tex-104-E, Tex-105-E, Tex-106-E, and Tex-110-E. Samples shall be taken randomly at a minimum of one location per 1,000 linear feet of each roadbed on alternating sides of the width of the road bed and when a recognizable change in the select fill material is encountered during grading operations. Samples shall be taken at any borrow source with frequency equivalent to the in situ testing. Sample frequency for a borrow source must be submitted and approved by the Mobility Authority prior to the commencement of hauling from that borrow source. The results of borrow source and in situ testing shall meet the requirements for the applicable embankment item. If the materials fail to meet the criteria for the applicable embankment item, the DB Contractor shall be responsible to take corrective action that is acceptable to the Mobility Authority.

Compaction. Embankment Item 132 (TY C1) and (TY B) shall be compacted as specified in TxDOT Item 132.3.4.2, Density Control. If water must be added, it shall be uniformly applied and thoroughly mixed into the lift by disking or scarifying. If a fine-grained material is used for Select Fill, very close moisture content control shall be required to achieve the recommended degree of compaction.

Bridge Abutment Backfill and Embankment Requirements. The TxDOT Standard Cement Stabilized Abutment Backfill (CSAB) shall be used at all bridges. When limits of CSAB conflict with MSE select backfill, MSE select backfill shall be used. In addition, all embankment (Item 132 (TY C1),, and (TY B)) below the pavement thirty (30) feet beyond the approach slab or fifty (50) feet from the abutment face, whichever is longer, shall be placed in uniform layers no greater than 8 in. deep (loose measurement) and shall be compacted using density control to a relative compaction of at least 95 percent of maximum dry density determined using Tex-113-E, with moisture within ± 2 percent of optimum.

20.3 Pavement Texture

All existing and widened general purpose lanes, auxiliary lanes, and outside shoulders within the Project limits shall receive Next Generation Concrete Surface (NGCS) treatment using diamond grinding and grooving techniques in accordance with TxDOT SS 3012, and subsequently sealed in accordance with TxDOT Item 428 as modified below. In areas where NGCS is applied adjacent to pavement with a different surface treatment, the NGCS treatment shall be feathered to provide a surface such that there is no water accumulation and adequate surface drainage flow is achieved.

ITEM 428 – Penetrating Concrete Surface Treatment

Use Hydropel or approved like material that meet the following specifications:

TESTING

Water absorption (Fed Spec SS-W-110-C)	0.3%
Water Absorption Reduction (NCHRP 244, Series II)	72%
Water Penetration Reduction Under ‘Wind Driven Rain’ (ASTM E514)	89%
Chloride Intrusion Reduction (NCRHP 244, Series II)	76%
Accelerated Weathering Reduction in Soluble Chloride (NCRHP 244, Series IV)	90%

All Express Lanes, inside shoulder, buffer, ingress/egress, and speed change lanes associated with Express Lanes shall receive longitudinal grooving treatment (for existing pavement) or longitudinal tining (for proposed pavement).

Before widening the existing pavement, the DB Contractor shall perform sufficient grooving and NGCS treatment and achieve an IRI value of 95 or less. Such grooving and NGCS treatment shall be of sufficient width to provide for a compliant abutting pavement surface.

20.4 Pavement Testing

The DB Contractor shall test the pavement surface for surface smoothness and ride quality to determine areas requiring corrective action. When corrective action is complete the Mobility Authority will perform

QA testing to verify that the corrective action has brought the pavement within the required limits listed in this Technical Specification. Additional iterations of QA testing due to insufficient QC testing as determined by the Mobility Authority will be charged to the DB Contractor.

Testing Specification. Measure and evaluate profiles using Surface Test Types A and B on surfaces as described below.

Surface Test Type A. Use a 10-foot straightedge.

Surface Test Type A shall be used for the following measurements:

- Transverse Profile of the finished riding surface.
- Longitudinal profile (including horizontal curves) of:
 - Bridge structures and 100 feet leading into and away from such structures.
 - Shoulders.
 - Reconstructed cross streets.
 - The first and last 100 feet of the project pavement length.
 - Leave-out sections as determined by the Mobility Authority.

Surface Test Type B. Use a high-speed or lightweight inertial profiler, certified at the Texas Transportation Institute, which is driven by a certified profiler operator from TxDOT's approved list.

Surface Test Type B shall be used for the following measurements:

- Longitudinal profile (including horizontal curves) of:
 - All express and general purpose lanes.
 - All ramp lanes. Auxiliary lanes on main lanes and frontage roads shall be included in ramp runs. (Existing frontage road pavement outside of the physical extent of ramp reconstruction is not required to be tested.)
 - All collector-distributor lanes.

Quality Control (QC) Testing. The DB Contractor shall perform QC tests using a straightedge, inertial profiler, profilograph, or any other means to determine any locations requiring corrective action prior to acceptance testing.

Any high-speed or lightweight inertial profiler used must be certified at the Texas Transportation Institute and display a current decal on the equipment indicating the certification expiration date. The DB Contractor must provide the Mobility Authority with equipment certification documentation. Use a certified profiler

operator from TxDOT's approved list. When requested, furnish the Mobility Authority with documentation for the person certified to operate the profiler.

QC testing on flexible pavement shall be done before the roadway is open to traffic on the final structural HMA course (before the final HMA surface course). QC testing on concrete pavement shall be done on the final surface before the roadway is open to traffic.

Final results of QC testing shall be submitted to the Mobility Authority within three Business Days for review. Provide all profile measurements in electronic data files using the format specified in Tex-1001-S.

Acceptance Testing. The Mobility Authority will perform acceptance tests on the finished surface of the completed project or at the completion of a major stage of construction as determined by the Mobility Authority.

The DB Contractor shall be responsible for sweeping the roadway prior to acceptance testing to prevent any high IRI results due to dirt and debris on the road. The DB Contractor shall be responsible for providing personnel to clear travel lanes of obstacles, police officers for intersections, and moving traffic control in accordance with TxDOT Standards as directed by the Resident Engineer. The Resident Engineer may require acceptance testing to be performed at times of off-peak traffic flow. All costs incurred by the DB Contractor (i.e., sweeping, traffic control, etc.) related to the acceptance testing shall be part of the Work. To reduce these costs it is recommended that the DB Contractor complete QC testing and any corrective action early enough to allow acceptance testing prior to opening the road to traffic.

For all pavements subject to Surface Test Type A, the acceptance testing shall measure surface areas to find locations that have more than 1/8-inch variation between any two contacts on a 16-foot straightedge.

For all pavements subject to Surface Test Type B, the acceptance testing shall measure the IRI for each traffic lane in 0.10-mile sections. Two IRIs shall be made for each lane, one in each wheel track. The reported IRIs shall be (i) the average of the two IRIs, and (ii) the wheel track with the highest IRI. The following values represent the maximum acceptable IRI for all pavements, regardless of type.

- Average of two wheel tracks: 80
- Highest recorded wheel track: 95

Corrective Action. Results not meeting the requirements given above for the two Surface Test Types shall require corrective action by the DB Contractor to repair the pavement. Such action shall be:

- Based on FHWA, AASHTO, TxDOT, and/or U.S. Army Construction Engineering Research Laboratory methods.
- Subject to the Mobility Authority's review and written acceptance.

Any variations to the criteria must be approved in writing by the Mobility Authority. Neither diamond grinding nor reheating and rolling shall be allowed as a method of corrective action on the final surface course of flexible pavement.

The Mobility Authority will perform acceptance tests on the finished surface after corrective action is performed. Results not meeting the requirements given above for the two Surface Test Types shall require further corrective Action. After making corrections, it is recommended that the DB Contractor retest using the appropriate Surface Test Type prior to acceptance testing to verify that corrections have produced the required improvements.

Penalties and Payment. TxDOT Specifications Item 585 Pay Adjustment Schedules shall not be used. The work performed, materials furnished, certification and recertification, traffic control for all testing, materials and work needed for corrective action, equipment, labor, tools, and incidentals shall not be measured or paid for directly but shall be subsidiary to pertinent Items.

TxDOT Specifications Item 360 Concrete Pavement shall be used for measurement and to determine limits for applying payment adjustment. Payment adjustment due to deficient thickness shall be in accordance with **Table 20-7**.

Table 20-7: Deficient Thickness Payment Adjustment

Deficiency in Thickness Determined by Cores (in.)	Deduction (\$/SY)
Not deficient	0.00
Over 0.00 through 0.20	0.00
Over 0.20 through 0.30	11.20
Over 0.30 through 0.40	15.68
Over 0.40 through 0.50	17.92
Over 0.50 through 0.75	24.08

20.5 Submittals

Table 20-8: Submittals to Mobility Authority

Submittals	Submittal Schedule	Mobility Authority Action	Reference Section
CRCP Joint Plan	With: 1. Preliminary (30%) Design Submittal, 2. Intermediate (65%) Design Submittal, 3. Final (100%) Design Submittal	Acceptance	20.2.1
Proof Roll Mitigation	As needed	Review & Comment	20.2.5
Sample frequency for a borrow source	Prior to the commencement of hauling from that borrow source.	Approval	20.2.6

21.0 TOLL SYSTEM

21.1 DB Contractor Responsibilities

The DB Contractor's responsibilities, relating to the toll systems, fall into four general areas: site, subgrade, at grade, and above grade. All construction materials shall be in accordance with these Technical Provisions. The DB Contractor shall not use any experimental, or previously unapproved materials, for incorporation into the Project.

Site: Working with the Mobility Authority's System Integrator (SI), the DB Contractor must design, procure, and/or construct various site infrastructure elements, including site Work, parking and maintenance driveways/level pads, and power and communication services to support the installation of the toll collection system in accordance with these Technical Provisions and Exhibit C – Attachment 21-1 – Toll Facility and ITS Responsibility Matrix.

Subgrade: In coordination with the SI and per SI requirements, the DB Contractor shall design and construct conduits and Duct Bank systems for communication, permanent power distribution systems, and backup power systems (including natural gas generators) needed for the toll system. The DB Contractor is responsible for all permanent and backup electrical power service, conductor wire for service, feeder and branch circuit conductors needed to provide power to SI equipment cabinets and other equipment as required by the SI. The SI is responsible for all fiber optic cable needed for the toll system. Other Subgrade responsibilities include, but are not limited to, conduits, utilities, gantry foundations and drainage systems shall be coordinated with the SI and accommodate the SI's toll collection system. Unless otherwise specified herein, the Work shall be governed by TxDOT Standards and Specifications. The DB Contractor is responsible to coordinate with the SI, and include the toll collection systems subgrade requirements into the Project Design. All subgrade infrastructure design shall accommodate the Ultimate Design.

At Grade: In coordination with the SI and per SI requirements, the DB Contractor shall design and construct various at grade elements including, but not limited to, pavement sections, site Work, maintenance driveways, power services to support the installation of the toll collection system, and all junction boxes and conduit. The DB Contractor shall construct, as part of the Work, all paving and roadway Work, and special pavement sections at tolling points. The DB Contractor shall design and construct primary power service and the facilities required to support the emergency natural gas generator backup electrical service systems as per the SI requirements. The DB Contractor shall provide electrical service at a meter/service panel including wire and disconnect switch, located immediately adjacent to, or in, the proposed roadside cabinets at each toll collection location. The DB Contractor shall provide the meter/service panel as part of the Work. The DB Contractor is responsible for all electrical power service, feeder and branch circuit conductors, lightning protection, and electrical grounding systems. In coordination with the SI and per their requirements, the DB Contractor shall design and construct the concrete slabs to support the

environmentally controlled roadside cabinets that house and support the physical components of the toll collection system. All at grade infrastructure design shall accommodate the Ultimate Design.

Above Grade: In coordination with the SI and per SI requirements, the DB Contractor shall design and construct various above grade elements, including but not limited to: gantry columns, gantry truss to support the installation of the toll collection system, equipment support framing on gantry truss, fencing, guardrails, construction of the roadway, and other miscellaneous civil works. The DB Contractor shall design and install all signage related to each tolling location. The DB Contractor shall design and construct gantries and toll equipment supports as per the SI requirements. All guide, warning, regulatory, and special toll signs pertaining to the Work shall be in accordance with TxDOT standards and the TMUTCD. All above grade infrastructure design shall accommodate the Ultimate Design

Special Considerations: In coordination with the SI and per SI requirements, the DB Contractor must design and construct facilities that shall accommodate the installation and operation of the electronic toll collection system. It is the responsibility of the DB Contractor to fully integrate the SI's plans and schedule, provide qualified and experienced designers, and be aware of various constraints and considerations within the toll collection zones.

21.2 Tolling Facilities

The tolling system will not include collection of cash. The toll system shall be designed to support all electronic toll collection. Structures are required to support electronic tolling.

To support the toll system components and communication between the tolling points and Mobility Authority's internal and external interfaces, the DB Contractor's procurement and installation responsibilities shall include, but not be limited to the following:

- Conduit – At the tolling point, below and above grade conduit is required to support power and communication delivery between toll system components.
- Duct Bank – A Duct Bank, in accordance with Technical Provision 18, is required along the entire length of the Project. Lateral conduits are required to reach the tolling points, to support connectivity with adjacent facilities and to support various tolling components along the road.
- Mounting Brackets – Working closely with the SI and per SI requirements, the DB Contractor must design, procure and install proper mountings (hangers/brackets/frames) for the toll system equipment.

The SI shall be responsible for the installation, termination and testing of the fiber optic cables in the Duct Bank required for the toll system, including fiber optic cable laterals and all fiber and communications required at each tolling point.

21.2.1 Subgrade Infrastructure

The DB Contractor's design and construction of all conduit and the Duct Bank shall be in accordance with:

- NESC
- NEC (NFPA 70) National Electrical Code
- TXDOT Electrical Design Standards and Details
- Mobility Authority's Fixed Price Tolling Standards provided in Exhibit D – Item 3
- SI requirements
- Exhibit C – Attachment 21-1 – Toll Facility and ITS Responsibility Matrix

The DB Contractor is responsible for all below grade electrical facility grounding circuit and lightning protection system conductors. The electrical facility grounding design shall comply with:

- NFPA 780 Standard for the Installation of Lightning Protection Systems
- NEC (NFPA 70) National Electrical Code
- NESC C2 National Electrical Safety Code
- USDA RUS Bulletin 1751F802 Electrical Protection Grounding Fundamentals
- TXDOT Electrical Design Standards and Details

The DB Contractor's design and construction of all electrical service, feeder and branch circuits shall be in accordance with:

- NEC (NFPA 70) National Electrical Code
- TXDOT Electrical Design Standards and Details
- Mobility Authority's Fixed Price Tolling Standards provided in Exhibit D – Item 3
- SI requirements
- Exhibit C – Attachment 21-1 – Toll Facility and ITS Responsibility Matrix

The DB Contractor's design and construction of conduit and equipment in support of communication services shall be in accordance with:

- USDA RUS Bulletin 1751F-640 Design of buried plant, physical considerations
- NEC (NFPA 70) National Electrical Code
- TXDOT Electrical Design Standards and Details
- Mobility Authority's Fixed Price Tolling Standards provided in Exhibit D – Item 3

- SI requirements
- Exhibit C – Attachment 21-1 – Toll Facility and ITS Responsibility Matrix

21.2.2 At-Grade Infrastructure

Horizontal Alignment. The main lane toll approach and departure areas shall be located in a relatively straight segment of roadway enabling adequate sight distance for identification on approach. If main lane approach/departure area or toll collection area requires a curve, the minimum radius shall be 12,000 feet.

Cross Slope. Through the toll collection area the lanes shall have a 2% minimum cross slope. Adequate care should be taken to ensure the roadway drains properly with no ponding or sheet flow.

Pavement. Pavement requirements shall be in accordance with *Technical Provision 20* and *Exhibit C – Attachment 21-1 – Toll Facility and ITS Responsibility Matrix*. Concrete pavement requires reinforcement with non-steel components within the tolling zone.

Parking and Maintenance Driveway/Level Pad. The DB Contractor shall be responsible for the design and construction of various parking and maintenance driveway/level pad components to support the installation and maintenance of the toll collection system at all toll site locations. All parking and maintenance driveways/level pads shall be placed in a location identified by the SI, and approved by the Mobility Authority. Parking and maintenance driveways/level pads are included to support the installation and maintenance access of the toll collection system. Parking and maintenance driveways/level pads shall be designed to comply with the *TxDOT Roadway Design Manual: Appendix C Driveway Design Guidelines*. Each parking and maintenance driveway/level pad footprint shall be large enough to accommodate a single-unit bucket truck to allow for SI access.

Bonding and Grounding. The DB Contractor is responsible for all electrical facility grounding circuits and lightning protection systems and conductors. All conductors entering the toll facility shall be protected, bonded and grounded to route lightning strike currents away from all electrical and electronic systems. The DB Contractor shall design and construct the electrical facility grounding system in accordance with:

- NFPA 780 Standard for the installation of Lightning Protection Systems
- IEEE 142 Recommended Practices for Grounding of Industrial and Commercial Power Systems
- NEC (NFPA 70) National Electrical Code
- NESC C2 National Electrical Safety Code
- USDA RUS Bulletin 1751F802 Electrical Protection Grounding Fundamentals
- TXDOT Electrical Design Standards and Details

Electrical Service. The DB Contractor is responsible for all electrical power services, feeder and branch circuit components, apparatuses, and conductors. The DB Contractor shall design and construct primary

service systems as per the SI requirements. The DB Contractor shall design and construct all electrical service, feeder and branch circuits as per:

- NEC (NFPA 70) National Electrical Code
- NFPA 37 Standard for the Installation and Use of Stationary Combustion Engines and Gas Turbines
- IEEE C62.41 IEEE Guide on the Surge Environment in Low-Voltage (1,000 V and Less) AC Power Circuits
- USDA RUS Bulletin 1751E-320 Emergency generating and charging equipment
- TxDOT Electrical Design Standards and Details
- NFPA 99 for generators in healthcare facilities
- Emergency Power Supply System: NFPA 110, Level 2
- Mobility Authority's Fixed Price Tolling Standards provided in Exhibit D – Item 3
- SI requirements
- Exhibit C – Attachment 21-1 – Toll Facility and ITS Responsibility Matrix

Communications. The DB Contractor shall design and construct conduits and the Duct Bank for power and communication services to support the installation of the toll collection system in accordance with:

- USDA RUS Bulletin 1751F-640
- IEEE 62.64 Standard Specifications for Surge Protectors Used in Low-Voltage Data, Communications, and Signaling
- NEC (NFPA 70) National Electrical Code
- TXDOT Electrical Design Standards and Details
- Mobility Authority's Fixed Price Tolling Standards provided in Exhibit D – Item 3
- SI requirements
- Exhibit C – Attachment 21-1 – Toll Facility and ITS Responsibility Matrix

21.2.3 Above Grade Structures for Electronic Toll Collection (ETC) System

The DB Contractor shall design and construct the required structures to support the installation and operation of the toll system in accordance with Exhibit C – Attachment 21-1 – Toll Facility and ITS Responsibility Matrix and the Mobility Authority's *Fixed Price Tolling Standards* provided in Exhibit D – Item 3 – Technical (Tolling).

Equipment Enclosures. Equipment enclosures shall be used to house the toll collection equipment and ITS components. In coordination with the SI and per their requirements, the DB Contractor shall establish the

precise location of each equipment enclosure. The remote equipment enclosures shall meet the SI mechanical, electrical, environmental and security requirements.

Gantries. The toll collection system shall require gantries and gantry truss structures to mount antennas, cameras, vehicle separation equipment and other toll system components. In coordination with the SI and per their requirements, the DB Contractor shall establish the precise locations for each of the gantry structures. Gantries (e.g. foundation, tower and truss design) shall be in accordance with TxDOT OSBS requirements, and shall meet the requirements found in Exhibit C – Attachment 10-1 – 183 North Mobility Project Aesthetic Design Guide.

Generator Power Source. The DB Contractor shall design and construct primary electrical service, and design and construct the site improvements required to support the emergency natural gas generator backup electrical service systems. The DB Contractor shall provide conduits for gas lines to the equipment pads per SI requirements. The SI will design, procure, and install the generators at each of the toll point locations.

The DB Contractor shall provide the generator power source as required in Exhibit C – Attachment 21-1 – Toll Facility and ITS Responsibility Matrix. Due to the potential for restrictions where natural gas generator(s) can be used along the 183 North corridor, the DB Contractor shall coordinate with the Mobility Authority to identify all locations along the corridor where natural gas generators can be used, as well as locate sites and determine the type of emergency backup generators allowable at locations where natural gas is restricted. Potential sources of natural gas supply are indicated in **Table 21-1**.

Table 21-1: Natural gas lines in proximity to proposed toll gantries

Item No.	Proposed Toll Gantry Location	Existing Natural Gas Line/Material/Size	Existing Gas Line Location
1	Toll gantry Between Lakeline Mall Dr and SH 45	Texas Gas Service/PE/2"	Along 183 NB SW
2	Toll gantry just north of Pond Springs Road	Texas Gas Service/STL/8"	Along 183 NB SW
3	Toll gantries (183 & DC) between Loop 360 and MoPac	Texas Gas Service/STL/12"	Along 183 NB/SB
4	Toll gantry along MoPac NB at 183/MoPac interchange	Texas Gas Service/STL/12"	Along 183 NB/SB

Signage. The DB Contractor shall be responsible for the design and construction of the toll facility signage.

21.3 Toll Systems

The DB Contractor shall coordinate its design and construction of all facilities needed to accommodate the final installation of the toll collection and enforcement operating system components with the Mobility Authority’s System Integrator.

The SI will have the responsibility for the design, procurement, and installation of the toll system and required communications.

The responsibilities of the DB Contractor in this regard, and the relation of such responsibilities to the responsibilities of Mobility Authority's System Integrator are detailed in Exhibit C – Attachment 21-1 – Toll Facility and ITS Responsibility Matrix.

21.4 DB Contractor's Coordination Responsibilities with System Integrator

The SI will be responsible for designing, developing, supplying, installing, configuring, and testing the Toll Collection System for the Project.

The DB Contractor shall coordinate the design and construction with the SI to accommodate the design and systems operating software, and ensure the Project schedule incorporates the time required to design, construct, procure, integrate and test all equipment to be used by the Mobility Authority during tolling operations and maintenance of the Project.

The DB Contractor shall coordinate closely with the Mobility Authority and SI to ensure the DB Contractor's design corresponds with the SI's toll system requirements and the Mobility Authority's *Fixed Price Tolling Standards* provided in Exhibit D – Item 3 – Technical (Tolling). The DB Contractor shall provide a minimum of fifteen (15) days for the SI's review and comment on all versions of the DB Contractor's design. At the 65% design stage, the Mobility Authority will coordinate with the DB Contractor and the SI to validate the infrastructure design for the toll system.

The DB Contractor shall coordinate with the Mobility Authority and the SI during the design and construction of the Project, and shall provide notice of any changes in design within and in close proximity to any toll site. The DB Contractor shall coordinate construction activities for the SI to construct and install toll system elements for each toll site concurrent with the DB Contractor's Work.

The DB Contractor shall coordinate with the SI and the Mobility Authority to incorporate the SI schedule into the Project Schedule. The DB Contractor shall establish regular meetings with the SI and Mobility Authority to ensure the SI's scheduled tasks, dependencies, and durations are accurately incorporated, and provide regular updates to the Mobility Authority and SI regarding construction status and progress. The DB Contractor shall be required to distribute an updated schedule and meeting agenda to the SI and Mobility Authority prior to every meeting, and distribute meeting notes after each meeting.

Upon the completion of construction at each toll and ITS site owned by the Mobility Authority, the DB Contractor shall coordinate with the SI and Mobility Authority to review the constructed infrastructure prior to acceptance of each site by the Mobility Authority. A site shall not be considered complete until it is accepted by the Mobility Authority.

The DB Contractor shall provide one hundred and twenty (120) days, prior to Substantial Completion or the DB Contractor's request for an incentive-related payment, whichever occurs first, for the SI's installation and testing of toll equipment at each Toll Gantry. The DB Contractor shall provide ninety (90) days at each toll gantry for the SI to complete installation activities, and thirty (30) days at each toll gantry to complete testing activities.

- The DB Contractor shall coordinate with the SI and Mobility Authority to develop a Toll and ITS Installation and Testing Dependency Matrix to specify what infrastructure the DB Contractor must have in place before the SI can begin toll system installation activities. See in Exhibit C – Attachment 21-2 – Toll System Installation Dependency Matrix for an example of the Toll and ITS Installation and Testing Dependency Matrix. For example, at each Toll Gantry, the DB Contractor shall complete the following items of the Work prior to the SI commencing installation:
- Coordination with the SI to install/saw cut in-ground loops prior to final paving/application of PFC.
- Complete Toll Gantry structures.
- Toll hangers installed.
- Layout of striping configuration (lane striping does not have to be permanent striping, but must be laid out in permanent lane configuration under the gantry).
- Loop stub-ups.
- Toll equipment pads complete.
- Gantry conduits to equipment pads verified and complete.
- Complete Duct Bank and conduits in vicinity of Toll Gantry location.
- Installation of permanent power to the cabinet.
- Support foundations required for SI equipment installations.
- ILP and Roadside cabinet slabs with required illumination.
- Lightning protections and grounding systems.

The aforementioned items shall be completed to meet the Toll Gantry Completion Deadline(s).

The DB Contractor shall coordinate with the SI and Mobility Authority to develop a Toll and ITS Installation and Testing Dependency Matrix to specify what infrastructure the DB Contractor must have in place before the SI can begin testing activities. See Exhibit C – Attachment 21-2 – Toll Installation Dependency Matrix for an example of the Toll and ITS Installation and Testing Dependency Matrix. For example, at each Toll Gantry, the DB Contractor shall complete the following items of the Work prior to the SI commencing system testing:

- All items to begin toll equipment installation (as noted above).
- Final pavement through the toll site, extending at a minimum of 500 feet on both sides of the toll gantry. The DB Contractor shall coordinate with the SI and the Mobility Authority to determine final length of pavement needed on each side of the toll gantry, at each toll site, in order to provide a smooth transition area through the toll zone for system configuration and testing.
- Complete Duct Bank Work for Project.

The aforementioned items shall be completed to meet all system testing deadlines.

The DB Contractor shall design a traffic control plan and provide traffic control devices and safe working conditions for the SI during the installation of all toll and ITS equipment. During SI installation and testing, the DB Contractor shall maintain traffic control and access to work space necessary for safe installation and testing operations. The DB Contractor shall keep the area immediate to, and within, the testing location free of any work crews, materials, debris, equipment, trucks driving through the test area in the wrong direction, and other conditions that prevent the SI from testing their system during testing periods. The DB Contractor shall be required to regularly meet and coordinate with the SI to communicate sequencing of toll gantry construction sites in order to communicate the order in which sites will be ready for installation and testing for the SI's planning purposes.

The Mobility Authority may assess Liquidated Damages in accordance with Section 18.1.2 of the DBA for the DB Contractor's failure to meet each Toll Gantry Completion Deadline.

The SI will require five (5) Days for installation and local testing of the Mobility Authority's ITS equipment at each ITS location owned by the Mobility Authority. The DB Contractor shall assume installation and testing can occur at only one location at a time.

The DB Contractor shall coordinate with the SI and Mobility Authority to develop a Toll and ITS Installation and Testing Dependency Matrix to specify what infrastructure the DB Contractor must have in place before the SI can begin installation activities for the Mobility Authority's ITS equipment. See Exhibit C – Attachment 21-2 Toll Installation Dependency Matrix for an example of the Toll and ITS Installation and Testing Dependency Matrix. For example, at each ITS location owned by the Mobility Authority, the DB Contractor shall complete the following items of the Work prior to the SI commencing installation of the Mobility Authority's ITS equipment:

- Foundations and poles for camera, DMS (and/or VTMS), automated gate systems and microwave equipment.
- Complete Duct Bank and conduits for the equipment.
- Installation of permanent power to the equipment.
- Support foundations required for SI equipment installations.

- Roadside cabinet slabs if required.
- Power drops.
- Conduit laterals.

The DB Contractor shall not be directly responsible for performance by the SI; provided, however, it shall be the responsibility of the DB Contractor to integrate the facilities and services provided by the SI into the DB Contractor's Project Schedule, and to notify the Mobility Authority immediately if the DB Contractor determines that any action or inaction on the part of the SI will prevent the DB Contractor from meeting the accepted schedule.

The DB Contractor shall be responsible for coordinating with the Mobility Authority's SI to develop and construct the toll system and ITS infrastructure owned by the Mobility Authority, or any other elements relating to tolling of the express lanes. The DB Contractor's facilities coordination responsibilities include, but are not limited to, the following:

- Coordinating closely with the SI to assure the DB Contractor's design corresponds with the SI's requirements.
- Coordinating site acceptance with the Mobility Authority and/or their designated representative, as well as handover/transition activities.
- Organizing regular meetings between the DB Contractor, SI and Mobility Authority to maintain open lines of communication throughout the project, and communicate construction status, schedule updates and modifications, etc..
- Coordinating installation and testing activities as required in Exhibit C – Attachment 21-1 – Toll Facility and ITS Responsibility Matrix.
- Providing a monthly schedule clearly incorporating the SI's procurement, design, development, installation and testing activities.

The DB Contractor and the SI shall maintain ongoing communication regarding requirements applicable, and progress with respect to the systems infrastructure included in the Project as it relates to the tolling system with the Mobility Authority.

Final tolling operations for the Project, after Final Acceptance, will solely be the responsibility of the Mobility Authority or a third party vendor assigned to the Mobility Authority. The DB Contractor's responsibility for coordination of tolling operations shall cease upon completion of a successful test and Mobility Authority acceptance of all system components.

21.5 Submittals

Table 21-2: Submittals to Mobility Authority

Submittals	Submittal Schedule	Mobility Authority Action	Reference Section
Toll Collection System Infrastructure Design	With: 1. Preliminary (30%) Design Submittal, 2. Intermediate (65%) Design Submittal, 3. Final (100%) Design Submittal	Review and Acceptance	21.1
Toll and ITS Installation and Testing Dependency Matrix	1. Intermediate (65%) Design Submittal, 2. Final (100%) Design Submittal	Review	21.1
Traffic Control Plan	1. Intermediate (65%) Design Submittal, 2. Final (100%) Design Submittal	Review and Acceptance	21.4

22.0 MAINTENANCE OF TRAFFIC

22.1 General Requirements

The DB Contractor shall be responsible for the safe and orderly movement of traffic through and around the Project, from issuance of NTP 1 to Final Acceptance. Traffic must be given clear direction at all times as to which pathway to follow. The DB Contractor shall manage all Maintenance of Traffic (MOT) Work in strict compliance with the requirements of this *Technical Provision 22*, *TxDOT Standard Specifications for Construction and Maintenance of Highways, Streets, and Bridges*, adopted by TxDOT in November 2014, *Texas Manual on Traffic Control Devices (TMUTCD)*, *TxDOT Compliant Work Zone Traffic Device List*, *TxDOT Standard Sheets*, (i.e. *Work Zone, Barricade and Construction, Traffic Control Plan*) and all other Contract Documents.

22.2 MOT Plan

22.2.1 Development of MOT Plan

General. The DB Contractor shall develop a detailed MOT Plan that includes all construction stages and phases, and identifies opportunities to expedite construction throughout the course of the Project. The MOT Plan shall be prepared by the Traffic Control Engineer (*Technical Provision 22.4.1*). The MOT Plan shall:

- Advise, warn, and alert the traveling public of construction in advance of the Project termini and on all roads, streets, and public trails approaching or crossing the Project.
- Control and guide traffic through the Project.
- Provide for the safe passage of pedestrian traffic and bicycles.
- Provide for necessary flag persons.
- Provide safety precautions to protect workers and the traveling public.
- Be subject to the Formal Design Review Process.

General Contents. The DB Contractor's MOT Plan shall provide:

- Complete MOT plans and details for all stages of construction.
- Complete traffic control details.
- Completion of Applicable TxDOT Forms & Procedures for Lane Closures, Roadway Closures, and Detours.
- The appropriate design and details when temporary construction of any of the following is required to maintain traffic: traffic signals, detour roadways, bridges, retaining structures, drainage, and other miscellaneous construction.

Revisions. As construction progresses, and if unforeseen conditions are encountered, the DB Contractor shall respond to the current Project circumstances by proposing revisions of its MOT Plan that ensures both maintaining the Project schedule and meeting the traffic management objectives of the Project.

When either the DB Contractor or the Mobility Authority anticipate major deviations (Mobility Authority will make the final decision on what is a major deviation) from the MOT Plan or traffic control required for construction that is not included in the MOT Plan, the DB Contractor shall submit proposed MOT Plan revisions to the Mobility Authority for review and comment at least 10 Business Days prior to implementation of the revised MOT Plan. The DB Contractor shall resolve all comments on the revised MOT Plan to the satisfaction of the Mobility Authority and provide signed and sealed sheets prior to implementation of the revised MOT Plan.

Requested Modifications. The DB Contractor shall modify the proposed MOT Plan if requested by and as deemed necessary by the Mobility Authority.

22.2.2 Items in MOT Plan

The MOT Plan shall include (but not be limited to) the following items:

- Scaled roadway plans showing all existing traffic control devices that need to be retained, relocated, or removed, and all temporary traffic control devices that need to be installed, retained, relocated, or removed.
- Scaled drawings showing dimensions and material used for signs that are not detailed in the TMUTCD, with background color and the legend.
- The size and color of all standard traffic control devices.
- Temporary queue detection system (TxDOT Special Specification 6302) shall be implemented in both directions of US 183. At a minimum a Type 2 System (4 sensors and 1 PCMS unit) must be included at each end of US 183 24 hours a day/seven days a week throughout the duration of job. Traffic queue sensors must also be deployed every mile along US 183 in each direction. Every 3rd or 4th sensor should be collocated on a PCMS unit for displaying the queue messaging.
- Temporary speed monitoring system (TxDOT Special Specification 6307) shall be implemented in both directions of US 183. At a minimum travel speeds shall be displayed at each end of US 183 24 hours a day/seven days a week throughout the duration of job.
- Scaled roadway plans showing the location of each sign so it can be easily read in relation to the roadway and other traffic control devices. The use of numbers or letters as a reference for sign placement will not be permitted.
- Uniform standards, as required by the *TMUTCD*.
- Signed and sealed pavement designs for all detour pavements.

- Type and location of all temporary pavement markings to be installed, removed, or renewed for each stage, and locations where any existing pavement markings require removal.
- Locations where existing signs need to be covered in order to be consistent with traffic operations.
- Route and details of temporary pedestrian walkways.
- Locations where concrete barrier requires pinning due to drop-off conditions behind the barrier.
- Locations where existing MBGF should be replaced or extended to meet length of need due to reverse traffic flow.

22.2.2.1 Traffic Control and Sequencing Plans

The DB Contractor shall consider traffic control phasing issues very early in the development process. The Preliminary (30%) Design Submittal shall contain a Maintenance of Traffic (MOT) Plan including typical sections showing the sequencing of construction and a description of the traffic control phasing.

The DB Contractor shall provide the Mobility Authority and TxDOT with a MOT Plan concept presentation to the MOT Task Force and the Austin District prior to the Preliminary (30%) Design Submittal. The MOT Task Force is comprised of representatives of the DB Contractor, the Mobility Authority, TxDOT, municipal and county representatives having jurisdiction over the Project, law enforcement agencies, emergency response providers, all affected stakeholders, and other agencies. The MOT Plan concept shall include sufficient detail to ensure that the traffic control phases are clearly demonstrated and impacts to adjacent properties and cross streets are shown. The Mobility Authority and TxDOT will provide comments on the MOT concept. The Mobility Authority will not accept the Preliminary (30%) Design Submittal or any Early Release for Construction package until the DB Contractor resolves all comments from the MOT concept presentation to the satisfaction of the Mobility Authority. The DB Contractor shall utilize PowerPoint and roll plots to convey this concept at the meeting.

The DB Contractor shall not implement the MOT Plan until the MOT Plan has been through the Formal Design Review and accepted by the Mobility Authority. The DB Contractor shall coordinate MOT Plan review with other agencies as required and resolve all review comments to the satisfaction of the Mobility Authority. The DB Contractor shall prepare Traffic Control and Sequencing Plans as part of the MOT Plan that maintains traffic flow on all impacted facilities during construction of the Project in accordance with the requirements identified in this *Technical Provision 22*. The MOT Plan shall include sufficient information and details to adequately explain how the Project construction sequencing and phasing will occur throughout the Project construction.

22.2.3 MOT Design Criteria

Design Vehicle. The MOT Plan shall accommodate a WB-50 design vehicle.

Design Speed. The facility designated roadway classification, design speed and other roadway segment design criteria can be found in Technical Provision 11.

Speed Limits. Any reduction in the regulatory speed limit shall require approval from the Mobility Authority and a Texas Transportation Commission (TTC) minute order and is further subject to the provisions of the *Texas Manual on Uniform Traffic Control Devices* (TMUTCD) for such use. As specified in Section 6C.01 of the TMUTCD, reduced (construction) speed limits should be used only in the specific portion of the work zone where conditions or restrictive features are present.

When all Work is behind protective barrier, it may not be appropriate to display construction speed limit signs absent any other restrictive features.

Construction speed limit signs should be removed or covered when conditions have changed and no longer warrant a reduction in speed.

Number of Lanes. No fewer than the existing number of lanes shall be provided in each direction of travel at all times, unless otherwise approved by the Mobility Authority. For the mainline, a minimum of two general purpose lanes shall remain open unless otherwise approved by the Mobility Authority in accordance with Technical Provision 22.5.2.2.

Lane Widths. Each lane shall be a minimum of 11 feet wide.

Driveways. Pavement materials specified for construction of temporary driveway access shall be suitable for the types of vehicles using the driveway, allowing for forces imposed by turning, braking and acceleration under all weather conditions.

Referenced Standards and Guidelines. The geometric design of all portions of the MOT Plan (including, but not limited to, detours and temporary roadway construction) shall conform to the latest edition, unless otherwise specified of the following standards and guidelines:

- TxDOT Roadway Design Manual
- AASHTO A Policy on Geometric Design of Highways and Streets
- AASHTO Roadside Design Guide
- TxDOT Standard Specifications for Construction and Maintenance of Highways, Streets, and Bridges, adopted in November 2014
- Texas Manual on Uniform Traffic Control Devices (TMUTCD)
- TxDOT Standard Sheets (i.e. Work Zone, Barricade and Construction, Traffic Control Plan)
- TxDOT Compliant Work Zone Traffic Device List

- National Cooperative Highway Research Project (NCHRP) Report 350, *Guidelines for Work Zone Traffic Control Devices* (including crash testing of work zone Category II devices that went into effect on October 1, 2000)

22.2.4 MOT Plan Implementation

The DB Contractor shall implement all elements of the Released-for-Construction (RFC) MOT Plan and MOT details, including the construction and maintenance of all traffic control signing and traffic control devices. The DB Contractor may be required to alter traffic control signing, markings, devices, traffic signals, or other improvements outside the limits of the Project. Any such alteration shall be subject to review and approval by the Governmental Entity having jurisdiction over the area in consideration. When such changes are no longer required to maintain traffic, the DB Contractor shall return all such altered items to their original state within 5 Business Days, unless directed otherwise by the Mobility Authority.

The DB Contractor's MOT Plan for the Project shall be reviewed and approved by TxDOT and the Mobility Authority prior to any Work.

22.3 Traffic Analysis Techniques and Software

The DB Contractor shall use VISSIM for the analysis of any modifications to the baseline concept and/or to the maintenance of traffic operations included within the plans. Synchro may be used for optimizing signal timing, however, all results shall be obtained from VISSIM Version 11.00-08.

If proposing to use any software other than that listed, submit the proposed software along with verification data for Mobility Authority review and approval. Software used shall be the current version in effect as of NTP 1 unless otherwise specified. Update software programs throughout the Contract if mutually agreed upon by the Mobile Authority. All modeling shall comply with the requirements included within Oregon Department of Transportation's Protocol for VISSIM Simulation, provided in Exhibit D – Item 8 – Traffic.

22.3.1 VISSIM Modeling

The Owner has developed calibrated VISSIM Models along US 183 that should be used to determine the impact of MOT on traffic flow. Any lane closures outside the limits of operations shall require modeling. The DB Contractor shall analyze all peak hour lane closures within VISSIM and summarize the results within a Technical Memo for submittal to the Mobility Authority. The following guidelines shall be considered when evaluating MOT impacts. The future condition VISSIM models should also be used for analyzing Value-Added Concepts (VAC) and Alternative Technical Concepts (ATC) along US 183.

- Modifications to traffic flow behavior parameters shall not be allowed.
- Modifications to any distributions shall not be allowed.
- Modifications to the seed numbers shall not be allowed.
- A minimum of 10 runs is required to determine MOEs for all analyses.

- Modifications to the base VISSIM models by the DB Contractor should include all necessary updates to the VISSIM models, including reduced speed zones, vehicle routes, conflict areas, priority rules, and node/link evaluations.
- Modifications to the following VISSIM elements shall be allowed:
 - Traffic signal cycle lengths no greater than 150 sec.
 - Any adjustments to lane change parameters shall be documented.
- Measures of Effectiveness (MOE) shall be determined as follows:
 - Signalized Intersection – Average intersection delay using nodes.
 - **Table 22-1** depicts the existing average intersection delay/LOS. For intersections with LOS A or B, a decrease in LOS by one (1) letter grade will be permitted. For intersections with LOS C, D, E, or F, a 20% increase in delay will be permitted.
 - Density shall be used for US 183 general purpose lanes, ramps, and weaving segments. For segments with LOS A or B, a decrease by one (1) letter grade will be permitted. For segments with LOS C, D, E, or F, a 20% increase in density will be permitted.

A Traffic Analysis Tech Memo summarizing the VISSIM analysis should be submitted to the Mobility Authority. The Mobility Authority will review the VISSIM models to ensure compliance with the requirements and to provide feedback to the DB Contractor. It is essential that the traffic models submitted as part of the Proposal meet all of the requirements. The purpose of the evaluation is to ensure that any traffic operational impacts are acceptable. The traffic analysis shall be summarized in the Technical Memo and shall include:

- Traffic and Travel Characteristics at the Project Location – Include a summary of traffic and travel characteristics in the project area. This may include recurring congestion issues (pre-existing bottlenecks, high-volume areas, etc.) and non-recurring congestion issues (special event traffic issues, weather related delays, potential for incident related traffic congestion, etc.), heavy vehicle volumes, directional traffic, and recreational or seasonal traffic issues.
- Traffic Analysis Strategies – Include a brief description on how the expected traffic conditions during construction were determined. Include source and date of traffic data. Any traffic reduction factors or other parameters assumed for the calculations should be documented.
- Identify Measures of Effectiveness – List the measure of effectiveness used for the analysis, including capacity, volume, queue, diversion rates, density, average intersection delay, safety, etc..
- Mobility Implications of Construction Approach(es) – Discuss construction approaches that have the potential to impact mobility during the project. This may include lack of shoulders during construction that may require incident management strategies or doing work at night to reduce traffic delays.

- Modifications – Discuss what changes were made to the base VISSIM models, including changes to reduced speed zones, vehicle routes, conflict areas, priority rules, and node/link evaluations.
- Analysis Results – Compare existing and construction traffic conditions and operations, with and without work zone impact management strategies (where included). Traffic analysis should also address, in more quantitative manner than the general impacts assessment, the impacts on:
 - Access for residences, businesses, and non-emergency services.
 - Access for pedestrians, bicyclists and persons with disabilities.
 - Emergency service impacts (fire, ambulance, police, hospitals).
 - Safety.
 - Intersection traffic control (signal timing, signage, etc.).
 - Heavy vehicle traffic (including over-height, over-weight vehicles).
 - Transit operations (bus stops, school buses, other transit operations).
 - Travel times along the corridor.

The Mobility Authority may identify the need for additional analysis if deemed necessary based upon a review of VISSIM modeling.

Table 22-1: Signalized Intersection Average Intersection Delay Thresholds

Intersection	AM		PM	
	Vehicle Delay (s)	LOS	Vehicle Delay (s)	LOS
183 NB & Burnet	47.8	D	64.6	E
183 SB & Burnet	43.0	D	51.2	D
183 NB & 360	60.1	E	66.4	E
183 SB & 360	59.4	E	58.0	E
183 NB & Great Hills Trail	22.0	C	34.6	C
183 SB & Great Hills Trail	117.3	F	32.0	C
183 NB & Braker Ln	60.6	E	109.3	F
183 SB & Braker Ln	38.1	D	59.5	E
183 NB & Balcones Woods	29.3	C	36.4	D
183 SB & Balcones Woods	35.3	D	34.8	C
183 NB & Duval	47.4	D	45.7	D
183 SB & Duval	45.9	D	53.0	D
183 NB & Oak Knoll Dr	37.1	D	118.7	F
183 SB & Oak Knoll Dr	34.8	C	53.1	D
183 NB & McNeil Dr	69.0	E	80.9	F
183 SB & McNeil Dr	82.5	F	118.0	F
183 NB & Pond Springs Rd	91.5	F	35.5	D

Intersection	AM		PM	
	Vehicle Delay (s)	LOS	Vehicle Delay (s)	LOS
183 SB & Pond Springs Rd	239.6	F	42.1	D
183 NB & Anderson Mills	50.3	D	57.7	E
183 SB & Anderson Mills	35.8	D	375.6	F
183 NB & Lake Creek Parkway	74.4	E	63.7	E
183 SB & Lake Creek Parkway	76.0	E	94.0	F
183 NB & Pecan Park	24.2	C	24.6	C
183 SB & Pecan Park	19.6	B	24.4	C
183 NB & WB 620	30.8	C	37.2	D
183 SB & WB 620	33.0	C	44.9	D
183 NB & EB 620	28.4	C	46.4	D
183 SB & WB 620	20.8	C	53.5	D
183 NB & Lakeline Mall Dr	30.6	C	49.7	D
183 SB & Lakeline Mall Dr	62.5	E	54.0	D
Burnet & Waterford	60.6	E	66.3	E
Burnet & Rockwood	58.5	E	71.4	E
360 & Stonelake	48.5	D	54.6	D
Great Hills & Jollyville	66.3	E	64.0	E
Braker & Seton	94.2	F	52.3	D
Braker & Jollyville	58.4	E	61.3	E
Balcones & Jollyville	60.1	E	59.1	E
Duval & Jollyville	59.0	E	64.6	E
Oak Knoll & Jollyville	56.1	E	87.7	F
McNeil & San Felipe	63.9	E	68.2	E
McNeil & Parliament Pl	33.4	C	44.1	D
Anderson Mill & Pond Sprngs	56.8	E	56.8	E
Lake Creek Parkway & Pecan Park	36.8	D	29.3	C
Lakeline Mall & Lake Creek Parkway	43.2	D	32.4	C

Table 22-2: US 183 Freeway Segment Density Thresholds

Segment	Density (vehicles/mile/lane)			
	AM		PM	
	NB	SB	NB	SB
At Burnet Rd	19.3	19.3	20.9	22.0
At 360	16.5	26.9	14.0	24.6
At Great Hills Dr	24.8	29.6	29.1	25.9
At Braker Ln	25.7	22.3	22.5	26.0
At Balcones Woods	34.0	20.0	51.5	21.3
At Duval Rd	24.2	22.9	25.7	20.2
At Oak Knoll Dr	15.2	23.7	25.0	18.4

Segment	Density (vehicles/mile/lane)			
	AM		PM	
	NB	SB	NB	SB
At McNeil Dr & Pond Springs Rd	14.0	83.0	30.2	17.4
At Anderson Lane	10.5	67.8	23.7	12.3
At Lakeline Mall Dr/FM 620/Lake Creek Pkwy	8.7	66.5	15.1	9.0

Table 22-3: Loop 1 Freeway Segment Density Thresholds

Segment	Density (vehicles/mile/lane)			
	AM		PM	
	NB	SB	NB	SB
At Duval Rd	10.7	35.2	39.8	6.0
North of Braker Ln	19.2	28.9	67.0	21.0
At Steck Avenue	22.0	16.7	64.6	24.2
At Anderson Lane	28.2	16.5	62.2	22.2
At Far West	40.8	21.7	67.4	31.6
At Northland Drive/RM 2222	23.8	21.0	48.0	14.5

22.4 MOT Staff

22.4.1 Traffic Control Engineer

General. The DB Contractor shall provide at least one Traffic Control Engineer (TCE) to implement and manage the MOT on the Project. The Traffic Control Engineer shall be retained by the DB Contractor for the duration of the Project, and shall be available at the request of the DB Contractor’s Construction Manager, Design Manager and the Mobility Authority when necessary to change the staging, signal timing, and/or traffic control plans. Such changes include, but are not limited to, those affecting sequencing of traffic, scheduling of Work activities, access roads to Work areas, trucks hauling to and from the Project, additional signing, and any unforeseen situations. The Mobility Authority shall have the authority to approve the nominated TCE and can request a replacement if the current TCE is not performing the required responsibilities in an adequate or timely fashion as determined by the Mobility Authority in its sole discretion.

Qualifications. The TCE shall have the following minimum qualifications:

- A registered Professional Engineer’s license in the State of Texas, or such registration within 6 months of the Proposal Due Date.
- Ten years of experience in traffic and highway engineering with a contractor, a consultant, or a city, county, or state transportation agency.
- Working knowledge of the *TMUTCD*, work zone safety, geometric design of highways and streets, traffic signal timing, traffic studies, and traffic simulation models.

- The ability to demonstrate familiarity with MOT plans for similar projects.
- Understanding of the local jurisdictional and public concerns about the MOT Plan, including the off-site effects of the Project.

TCE Duties. The responsibility of the TCE shall be to manage the approved MOT Plan and its implementation. Other duties assigned to the TCE must have prior written approval from the Mobility Authority. The TCE's primary duties shall be to:

- Personally manage and supervise services at the Project site, and be the DB Contractor's contact for all MOT coordination with the Mobility Authority.
- Diligently work to develop an MOT Plan that meets both the DB Contractor's construction schedule and the Mobility Authority's requirements for public mobility during construction.
- Manage the ongoing revisions to the MOT Plan, including coordination between the DB Contractor's construction schedule and the MOT Plan.
- Attend all MOT Task Force meetings.
- Sign and seal the MOT Plan, MOT details, and all revisions in accordance with the plan submittal requirements.
- Supervise the implementation, maintenance, and inspection of all MOT details, either directly or through a certified and approved Traffic Control Supervisor (TCS).
- Coordinate all MOT details affecting city streets, pedestrian ways, and County roads to the proper jurisdiction before implementing traffic control on city streets and/or county roads.

22.4.2 Traffic Control Supervisor

General. All MOT implementation, inspection, and maintenance shall be performed under the direction of the TCE and shall be directly supervised by a TCS. The DB Contractor may assign one or more TCSs to work under the direction of the TCE and to act for the TCE in emergencies. At least one TCS shall be on duty at all times.

Qualifications. Unless otherwise approved by the Mobility Authority, each TCS shall have the following minimum qualifications:

- Certification as a Traffic Control Supervisor by the American Traffic Safety Services Association (ATSSA).
- Successful completion (including passing a written examination) of a work zone traffic control course approved by the Mobility Authority.
- Five years of work zone experience in a supervisory capacity within the past 10 years.

- Before beginning Work requiring traffic control management, the DB Contractor shall submit to the Mobility Authority a copy of the ATSSA Traffic Control Supervisor certificate / wallet-size card for every TCS used from NTP 1 to Final Acceptance, or a certification from another agency or firm as approved by the Mobility Authority.

TCS Duties. The primary duties of a TCS are to:

- Under the direction of the TCE, correct all deficiencies in the MOT implementation.
- Coordinate all traffic control operations of Subcontractors, Utilities, and suppliers to ensure that their operations are included in the approved MOT Plan and that they do not result in conflicting traffic control situations.
- Ensure that all traffic control operations performed by Subcontractors and suppliers meet all Project MOT requirements.
- Maintain a Project MOT Diary documenting MOT activities.
- Respond to CTECC calls and emails and inform the Mobility Authority of the status and resolution of all incidents.
- Submit lane closure notices and cancellations to the Mobility Authority as described elsewhere in this *Technical Provision 22*.
- Obtain the vehicle accident report from the local law enforcement agency for each accident reported within the Project and provide a copy to the Mobility Authority. Notify the Mobility Authority of any fatal traffic accident on the Project within 2 hours, while for any other nonfatal traffic accident, the reporting timeframe should be within 24 hours. Record the accident and the time and date of notification in the MOT Diary and submit it to the Mobility Authority.
- Have readily available at all times the most current copies of the following:
 - The approved MOT Plan
 - All approved MOT Details
 - *TMUTCD*

22.4.3 Traffic Simulation Modeler

General. All MOT microsimulation modeling shall be performed under the direction of a Traffic Simulation Modeler.

Qualifications. Unless otherwise approved by the Mobility Authority, the TSM shall have the following minimum qualifications:

- A registered Professional Engineer’s license in the State of Texas, or such registration within 6 months of the Proposal Due Date.

- Ten years of experience in traffic simulation modeling, including the analysis of freeways, HOV/managed lanes, and arterials for large scale projects.
- Working knowledge of the geometric design of highways and streets, traffic signal timing, traffic studies, and traffic simulation models.
- The ability to demonstrate familiarity with MOT plans for similar projects.
- The Mobility Authority shall have the authority to approve the TSM replacement if the TSM is not performing their duties adequately.

TSM Duties. The primary duties of a TSM are to:

- Manage and oversee MOT traffic modeling efforts.
- Ensure traffic simulation models meet all of the requirements defined in *Technical Provision 22.3.*
- Prepare documentation of results and model modifications as defined in *Technical Provision 22.3.*

22.4.3.1 Availability and Notification

An approved TCS shall be available 24 hours per day throughout the duration of the Project, including times of Project suspension. If the DB Contractor assigns more than one TCS to manage MOT, the DB Contractor shall submit a weekly schedule identifying who will manage MOT each day to the Mobility Authority or his designee.

At times when a TCS is not on-site, a TCS shall be on call and able to respond to the site within 30 minutes. The DB Contractor shall provide the Mobility Authority a telephone number to contact the on-call TCS.

22.4.3.2 MOT Diary and Traffic Control Device Installation Records

MOT Diary. The TCS shall maintain a Project MOT Diary in a format acceptable to the Mobility Authority. The TCS shall keep the Project MOT Diary current on a daily basis, and shall sign each daily entry. Photographs may be used to supplement the written text.

Traffic Control Device Installation Records. The TCS shall maintain records of what traffic control device are installed on the Project during each phase of the MOT plan. This shall consist of video documentation and a copy of the TCP plan sheets showing the dates when each traffic control device was installed and removed.

The Project MOT Diary and Traffic Control Device Installation Records shall at all times be available for inspection by the Mobility Authority. A copy of the Project MOT Diary and Traffic Control Device Installation Records shall be submitted to the Mobility Authority on a regular basis, as directed by the

Mobility Authority. The Project MOT Diary and Traffic Control Device Installation Records shall become the property of the Mobility Authority at the completion of the Project. Failure to submit the Project MOT Diary and Traffic Control Device Installation Records shall result in the withholding of final payment.

22.4.4 Local Traffic Control Crew

The DB Contractor must furnish the names, addresses, and telephone numbers of at least three local persons responsible for the placement and maintenance of traffic control devices. These persons must work for either the TCE or TCS. These persons must reside in the immediate proximity of the Project for the duration of the Project, and be on call 24 hours per day, 7 days per week, during the times that any traffic control devices furnished and/or installed by the DB Contractor are in-place. The required information must be submitted to the Mobility Authority at the preconstruction conference and updated and resubmitted as needed until Final Acceptance.

22.4.5 MOT Task Force

Membership. The DB Contractor shall establish a MOT Task Force, whose operations affect or are affected by the Project MOT Plan no later than 2 weeks after NTP 1. Membership in the MOT Task Force shall be approved by the Mobility Authority.

Meetings. The DB Contractor shall schedule and attend a minimum of two MOT Task Force meetings per month starting 4 weeks after NTP 1 until all phases of the MOT plan have been constructed. The purpose of these meetings is to:

- Further refine and develop the MOT Plan.
- Review the DB Contractor's MOT details.
- Disseminate Project MOT information to Task Force meeting attendees.
- Obtain MOT input from Task Force meeting attendees.
- Make MOT recommendations to the Mobility Authority.
- Coordinate and hold stakeholder meetings to present the TCP staging plans.

Minutes and Follow-up. The DB Contractor shall take meeting minutes and distribute them to the Mobility Authority within 5 Business Days of the meeting. Meeting follow-up items shall be the responsibility of the DB Contractor.

22.5 Lane Closures

22.5.1 General

The DB Contractor shall at a minimum comply with the traffic control standards along with the requirements below:

Inclement Weather. Temporary lane closures will not be permitted to be set up during inclement weather, while the pavement is wet, nor any other time when, in the sole opinion of the Mobility Authority, the lane closure is undesirable to traffic flow.

Qualified Flaggers. Qualified flaggers shall be provided in sufficient numbers and locations as necessary for control and protection of vehicular and pedestrian traffic. Qualified flaggers shall conform to the requirements set forth in the *TMUTCD*. The DB Contractor shall maintain a list of qualified flaggers on the Project and provide this list in writing to the Mobility Authority 5 days prior to the first operation requiring flaggers on the Project and any time thereafter when requested by the Mobility Authority.

Law Enforcement Officers. Provide a minimum of one law enforcement officer with a clearly marked patrol vehicle for each lane closed and an additional officer for each intersection, ramp, or roadway closed. This requirement is cumulative and if multiple lanes and/or intersections are closed, the DB Contractor will be required to provide multiple officers. Closures of signalized or stop-controlled intersections will require one officer for each set of signals/stop signs. For example, an intersection closure where a cross street intersects two frontage roads will require a minimum of two officers (one at each cross street and frontage road intersection) and an intersection where two sets of frontage roads intersect will require a minimum of four officers. Patrol vehicles must be clearly marked to correspond with the officer's agency and equipped with appropriate lights to identify them as law enforcement. For patrol vehicles not owned by a law enforcement agency, markings will be retroflected and legible from 100 ft. from both sides and the rear of the vehicle. Lights will be high intensity and visible from all angles.

Maintenance Closures. Lane closures required for maintenance repairs per *Technical Provision 24* shall be coordinated with the Mobility Authority at the time of discovery for approval of lane closure plan and repair implementation.

Moving Lane Closures. Truck-mounted attenuators (TMAs) shall be used for moving lane closures.

22.5.2 Restricted Dates and Times

The Mobility Authority shall have the right to lengthen, shorten, or otherwise modify the restrictions listed in this section as actual traffic conditions may warrant.

All lane closures including general purpose lanes, ramp, frontage road, shoulder, and cross street closures are prohibited during the events listed below unless special permission is granted by the Mobility Authority and TxDOT:

- Austin City Limits Music Festival.
- on any other high traffic days or holidays (up to 5 days per year) as determined by the Mobility Authority or TxDOT.
- For the following days or events, lane closures are not permitted after 3:00 PM on the day of:
 - Halloween
- For the following holiday weekends, lane closures and Work which restricts or interferes with traffic will not be allowed from 12 noon on the day preceding to 5 AM on the day after:
 - Memorial Day/Memorial Day weekend
 - July 4th
 - Labor Day/ Labor Day weekend
 - New Year’s Day
- For the following holidays, lane closures and Work which restricts or interferes with traffic are not permitted 1 day before and 1 day after:
 - Thanksgiving Day through Sunday
 - Christmas Eve/ Christmas Day

22.5.2.1 Allowable Non-Peak Lane Closures

Single-lane express lane, general purpose lanes, frontage road, shoulder, ramp, direct connector, and cross-street lane closures are permitted throughout the Project during the time frames identified in **Table 22-4**. In locations where the general purpose lanes or frontage roads have three lanes of traffic, two lanes may be closed during the periods identified in **Table 22-4**. One lane must remain open at all times unless approved by the Mobility Authority.

Table 22-4: Allowable Non-Peak Lane Closures

Day of Week	Morning	Evening
Monday – Friday	12:00 Midnight to 5:00 AM	9:00 PM to 12:00 Midnight
Saturday & Sunday	12:00 Midnight to 8:00 AM	9:00 PM to 12:00 Midnight

22.5.2.2 Lane Assessment Fees

Lane Assessment Fees will be assessed in accordance with **Table 22-7**, and will not be assessed for approved lane closures. Lane Assessment Fees will be deducted directly from the DB Contractor’s monthly Draw Request.

For the purpose of Lane Assessment Fees the following apply:

- The fee will be prorated in 15-minute increments.

- The first minute of a 15-minute increment will be assessed the whole 15-minute prorated fee.

Table 22-7 applies to all existing and proposed lanes throughout the Project limits for the duration of the Project. If general purpose traffic is switched to the proposed general purpose or express lanes, this traffic is still considered to be US 183 general purpose traffic.

General Purpose Lanes. A minimum of two general purpose lanes along US 183 must be maintained in each direction during peak times and during approved permitted lane closure. During non-construction activities, the number of open lanes must match the number previous to the start of construction.

Frontage Road Lanes. A minimum of two frontage road lanes along the US 183 Frontage Road must be maintained at all times. The outside frontage road lane (lane nearest the US 183 general purpose lanes) may be closed during off-peak periods as indicated in **Table 22-4** and only at the locations included in **Table 22-5**. Except as otherwise allowed, all lanes must be open 750 feet prior to each intersection.

Table 22-5: Allowable Frontage Road Lane Closures

From	To	Direction
Lake Creek Pkwy	Anderson Mill	SB; NB
Anderson Mill	Spicewood Springs Rd /McNeil Dr	SB; NB
Oak Knoll Dr	Duval Rd	SB; NB
Duval Rd	Balcones Woods Dr	SB; NB

U-Turn Deceleration Lanes at Interchanges. The U-Turn deceleration lanes at the interchanges included in **Table 22-6** may be closed. The U-Turn lane and movement itself must be maintained except for non-peak times as included in **Table 22-4**. If the U-Turn lane is closed, DB Contractor shall review signal timing and make improvements as necessary to minimize queueing that may result from increased traffic volumes through the intersection.

Table 22-6: Allowable U-Turn Lane Closures

Interchange	Direction
Lakeline Blvd	SB; NB
RM 620	SB; NB
Pecan Park Blvd	SB; NB
Lake Creek Pkwy	SB; NB
Anderson Mill Rd	SB; NB
Pond Springs Rd	SB
McNeil Dr/Spicewood Springs Rd	NB
Oak Knoll Dr	SB; NB
Duval Rd	SB; NB
Balcones Woods Dr	SB; NB

Interchange	Direction
W Braker Ln	SB
Great Hill Trail	SB; NB
Burnet Rd	SB; NB

Shoulders. Shoulders can be closed, as long as a 2-foot minimum distance from the toe of barrier to the edge of travel lane is maintained.

Moving/Rolling Closures. Moving/Rolling lane closures and mobile operations are subject to the same restrictions and Lane Assessment Fees as indicated in this Technical Provision 22. Moving equipment on active roadway segments shall be limited to non-peak hours.

Approved Closures and Detours. Mobility Authority approved roadway closures and detours as described in Technical Provision 22.5.3 will not be subject to Lane Assessment Fees described in this section unless otherwise specified by the Mobility Authority as a condition of approval for the particular roadway closure or detour.

Emergency Repairs. Lane closures required for emergency repairs that are determined by the Mobility Authority to have been caused by the DB Contractor's operations, defective materials and/or workmanship will be subject to Lane Assessment Fees.

Lane Assessment Fees are assessed at the hourly rates shown in **Table 22-7**. For example, if the DB Contractor has one northbound general purpose lane closed at Braker Ln on a Friday night (after 9 pm) and does not pick up the closure until 8:20 AM on Saturday morning, Liquidated Damages would be assessed as follows:

9:00pm (Fri) to 8:00am (Sat)	Allowable lane closure
8:00am to 8:15am (Sat)	\$25,000
8:15am to 8:20am (Sat)	\$25,000 (based on the full 15-minute period cost)
Total	\$50,000

Table 22-7: Lane Assessment Fees – General Purpose/Frontage Roads

Direction	Segment	Exist. # of Lanes	Applicable Closures	Morning Peak Hours (5–9 AM M–F)	Midday Hours (9 AM–3 PM M–F)	Evening Peak Hours (3–9 PM M–F)	Weekend Peak Hours (8 AM–9 PM Sat & 8 AM – 9 PM Sun)
NB	Project Limits	3	1L	\$100,000	\$50,000	\$100,000	\$100,000

Direction	Segment	Exist. # of Lanes	Applicable Closures	Morning Peak Hours (5-9 AM M-F)	Midday Hours (9 AM- 3 PM M-F)	Evening Peak Hours (3-9 PM M-F)	Weekend Peak Hours (8 AM-9 PM Sat & 8 AM - 9 PM Sun)
SB	Project Limits	3	1L	\$100,000	\$50,000	\$100,000	\$100,000

22.5.3 Detours

The DB Contractor shall use State routes for detour routes, wherever applicable. If State routes are unavailable, the DB Contractor shall use City and County roads, provided that the DB Contractor has obtained all necessary permits and concurrence from the owner of the facility. The DB Contractor shall be responsible for obtaining the necessary approvals from the Mobility Authority, the local, county, and state agencies having jurisdiction over routes used. The DB Contractor shall be responsible for any and all user cost which may be assessed for the use of these existing roads. This may include traffic operational analysis, temporary traffic control devices, and road user costs, all payable to the local road authority. The DB Contractor shall document the existing condition of the proposed detour route, by video, prior to diverting traffic onto the detour. All detours must be approved by the Mobility Authority prior to implementation.

Prompt Commencement of Work. To control negative public perception, detours shall not be set until Work is ready to commence on the closed roadway. Once closed, Work on the roadway shall be consistent and as continuous as possible until the road is re-opened.

Motorist Guidance. The DB Contractor shall provide motorists with proper signage and guidance on diverting around the construction, detouring around specific construction sites, and traveling through the construction areas. When detours are used, regional/local traffic signs shall be provided and/or maintained to ensure that the traveling public can stay on a marked route through the construction area.

Full Main Lane Closure. The DB Contractor may not close the US 183 and MoPac general purpose lanes without approval from the Mobility Authority and TxDOT. Full closures will be allowed between 10:00 pm and 4:00 am Sunday night to Thursday night and between 10:00 pm and 6:00 am Friday night and Saturday night. Construction activities such as traffic switches, beam erection, direct connector tie-ins, placement of gantries will be considered.

Frontage Road Lane Closure. To accommodate restricted construction access associated with reconstruction of the southbound Frontage Road as described in *Exhibit B – Scope of Work*, the DB Contractor may close all but one lane subject to the following provisions:

- Lane closures will only be permitted for the minimum time and extent necessary to safely complete construction activities.

- A single, continuous construction closure will be permitted at each of these locations between June 1st and August 15th.
- Lane closures at both locations may coincide.
- Outside of the nominated time the requirements of *Technical Provision 22.5.2.1* will apply.

Cross Street and Side Street Closures. Mobility Authority approval is required to close cross streets and side streets. In addition to Mobility Authority approval, the DB Contractor is responsible for obtaining approval for the closure from the appropriate agency having jurisdiction over the road. The DB Contractor is also responsible for informing and working with other entities impacted by the closure (i.e. school systems, post offices, businesses, emergency services). The DB Contractor’s proposal to close a cross or side street must be received by the Mobility Authority 6 weeks prior to the planned closure to provide the Mobility Authority with sufficient time to inform the public of the upcoming closure.

Contingency Plan. The DB Contractor shall provide the Mobility Authority with a contingency plan for reopening closed roadways, intersections, or ramps to public traffic in the event of an equipment breakdown, shortage of materials, lack of production of materials, or other production failure, or when it becomes necessary to reopen the closure for use by public traffic. The DB Contractor shall provide the contingency plan a minimum of 3 Business Days prior to closing the roadway, intersection, or ramp and resolve all Mobility Authority comments on the plan prior to proceeding with the closure.

Portable Changeable Message Signs (PCMS). All closures will require placement of one or more PCMS a minimum of 7 days in advance of the closure to advise the travelling public of the closure and detour route.

- The conditions for removing cross street access apply whether the removal is temporary as a phase of MOT or required as part of the final configuration of the project.

The DB Contractor shall provide the Mobility Authority with a letter 6 weeks prior to removing cross street access at any location in order to provide the Mobility Authority with sufficient time to inform the public of the upcoming changes.

22.5.4 Lane Closure Notices

- Lane Closures Notices (LCN) will be required for all closures.
- Lane Closures have two categories:
 - Full road or ramp closure with detour required.
 - Lane closure involving a single lane or various lanes of a roadway.
- Full road closures will require a minimum of a 14-day written notice and message boards are to be placed to advise the travelling public, as directed by the Resident Engineer. Detour routes

will be established by the DB Contractor and approved by the Mobility Authority prior to the 1 week notice. Late LCNs will not be accepted.

- Lane or ramp closures involving single or various lanes to be closed are required to be submitted in writing, no later than noon, 2 Business Days prior to the requested closure, regardless of whether the closure is a daytime or nighttime closure. Late LCNs will not be accepted.
- The DB Contractor shall provide the following information for all lane closure notices:
 - Date the LCN is submitted to the Mobility Authority.
 - Purpose of the closure.
 - Start and end dates of the closure.
 - Start and end times of the closure.
 - Lanes/Roads to be closed.
 - Limits of the closure (must be identified by names of the street/road, no station numbers will be used).
 - Detour routes, if required.

22.5.5 Traffic Switches

Switching Plan. At least 14 Days before switching traffic from one control stage to another, the DB Contractor shall submit a detailed step-by-step switching plan to the Mobility Authority for review and comment. The DB Contractor shall resolve all comments on the switching plan to the satisfaction of the Mobility Authority prior to the traffic switch. The plan shall consist of the procedures (i.e., signing and striping) necessary to complete the switch, revised signal timing for any signals affected by the switch, the number and duties of police officers assigned to perform the switch, and a contingency plan in the case of unforeseen events (i.e., inclement weather).

Requirements To Open. As each portion of the road is completed, the DB Contractor shall complete the following on or before the opening date approved by the Mobility Authority:

- Install the signing, guardrail, barrier, reflectors, delineators, and pavement markings required to safely open that road to traffic.
- Cover or remove all traffic control devices that may be inconsistent with traffic patterns.
- The requirements to open also apply to traffic switches for any phase of the traffic control plan.

22.6 Traffic Control Devices

Definition. Traffic control devices include (but are not limited to) barricades, barricade weights, warning signs, trailers, flashers, cones, drums, and pavement markings, as well as flaggers and off-duty police officers as required to properly maintain traffic.

General. The DB Contractor shall furnish, install, inspect, maintain, and remove all traffic control devices required to provide safe movement of vehicular traffic, including the immediate repair or replacement of all traffic control devices that are damaged, moved, or destroyed, and of all barricade weights that are damaged, destroyed, or otherwise fail to stabilize the barricades, throughout the Project from NTP 1 to Final Acceptance. Traffic control devices shall not be staged along the roadway prior to use. They must be placed at the time of usage and removed when the work is completed.

Requested Modifications. The DB Contractor must modify its traffic control devices if requested by and as deemed necessary by the Mobility Authority.

Inspection of Devices. The TCE or designated TCS shall inspect traffic control devices, as a minimum, according to **Table 22-8 (Traffic Control Device Inspection Schedule)**. These inspection frequencies include periods of Work suspension. At least 2 Business Days before placement, all traffic control devices must be available on the Project for inspection by the Mobility Authority.

Table 22-8: Traffic Control Device Inspection Schedule

Traffic Control Device	Inspection Frequency
Drums, Cones, and Portable Delineators	Twice Daily (at start and end of work day)
Signage on Portable Supports	Daily
Barricades with Delineators	Daily
Temporary and Permanent Traffic Signals	Daily
Detours and/or Alternate Routes	Daily
Portable Changeable Message Signs	Daily
Temporary Roadway Lighting	Nightly
Pavement Markings	Weekly
Fixed Signage	Weekly

Repair and Replacement. The TCE or designated TCS shall provide for the immediate repair or replacement of any traffic control device not functioning as required to ensure the safety of traveling public and construction personnel. The DB Contractor must respond within 1 hour to any call from the Mobility Authority or its designated representative concerning any request for replacing, improving or correcting improper or non-functioning traffic control devices. All required repairs must be substantially completed within 24 hours of notification.

Temporary Devices. The DB Contractor must conform to all requirements of Report 350 of the National Cooperative Highway Research Project (NCHRP) for temporary traffic control devices.

Sequential Arrow Displays. Each vehicle used to place, maintain, or remove components of a traffic control system on multilane highways shall be equipped with a sequential arrow display that shall be in operation when the vehicle is being used for placing, maintaining, or removing the components. Vehicles equipped with sequential arrow displays not involved in placing, maintaining, or removing the components when operated within a stationary type lane closure shall display only the caution mode. The sign shall be controllable by the operator of the vehicle while the vehicle is in motion. Sequential arrow displays used in moving lane closures shall be truck-mounted.

Truck-Mounted Attenuators (TMAs). TMAs shall be used during lane closure setup and removal, for mobile operations, as required by TxDOT standards, and as directed by the Resident Engineer to ensure worker and driver safety in the work zone.

22.6.1 Temporary Guardrail, Concrete Traffic Barriers, and Attenuators

Vehicle Protection. The DB Contractor shall be responsible for using temporary guardrail, concrete traffic barriers (CTBs) and/or attenuators to protect the traveling public. Low profile barriers shall only be permitted at locations with posted speed of 45 mph or less. Protection shall be provided for the following:

- Hitting fixed objects within the clear zone.
- Driving off drop-off areas that exceed the recommendation established by TxDOT for longitudinal joints and edge drop-off guidelines.
- Driving off slopes steeper than 3:1.

Temporary Guardrail. All guardrail installations must conform to TxDOT Standards.

Concrete Traffic Barrier & Attenuators. The DB Contractor will be responsible for furnishing and installing, moving and resetting, and removing all of the CTB, attenuators, and associated hardware that is required for the DB Contractor's MOT Plan.

22.6.2 Signage

General. The DB Contractor shall furnish, install, and maintain all temporary traffic control signs at the proper location as required in the *TMUTCD*.

Existing Signs. The DB Contractor shall maintain existing signs until they no longer apply or until permanent signs are installed. Any existing signs that still apply to traffic but are no longer in the proper location due to a traffic switch or new alignment shall be relocated or replaced with an appropriate temporary sign until permanent signs are installed.

Project-Specific. The DB Contractor shall provide for the manufacture and installation of four *TMUTCD* compliant project specific signs (location and design to be determined by the Mobility Authority). The cost of these signs will not constitute a Change Order.

Identification Signage. Street identification signage shall be maintained and be visible at all times. Where the only existing signs are small city or county signs located at the intersection, they shall be maintained by temporary installations as required by the Mobility Authority. This is, among other reasons, necessary to maintain the integrity of the 911 emergency system.

Covering. All signs installed on roads open to traffic that are not consistent with traffic operations shall be covered as directed by the Mobility Authority. If a cover is to remain in place for more than 30 days, it shall be a plate of solid opaque material covering the entire legend or all of that part of the legend that is inappropriate. The sign legend and/or sheeting shall not be damaged by the covered material. The DB Contractor shall replace the sign if damage to the sheeting occurs.

Post-Mounting. Temporary signs or relocated existing signs that will remain in the same location for an extended period of time shall be post-mounted as directed by the Resident Engineer. The signs must be mounted on posts driven into the ground at the proper height and lateral offset, as detailed in the *TMUTCD*.

Business-Specific Signs. DB Contractor shall provide temporary signs that call out business access points and/or guide motorists to businesses that are hard to find due to traffic shifts or changes in the permanent horizontal or vertical alignment. The need for these signs will be determined by the Resident Engineer and the cost of these signs will not constitute a Change Order.

Portable Changeable Message Signs (PCMS). In addition to what is required by TxDOT Standards and what is required in the Lane Closure portion of this *Technical Provision 22*, the DB Contractor shall provide PCMS to advise drivers of situations where existing, temporary, or permanent signing does not provide the needed information (i.e. advising motorists when tolls will begin). The need for these signs will be determined by the Resident Engineer and any cost associated with these signs (i.e. rental, operation) will not constitute a Change Order.

22.6.3 Pavement Markings

In work zones, additional emphasis must be placed on the application of pavement markings. Traffic must be given a clear direction as to which pathway to follow. The DB Contractor shall at a minimum comply with the following requirements:

- Refer to **Table 22-8** of this *Technical Provision 22* for the upkeep of traffic control devices.
- Temporary Raised Pavement Markings (TRPM) will be permitted where they are required to supplement a line. The DB Contractor shall inspect and replace all damaged or missing TRPMs every 2 weeks or as directed by the Resident Engineer. The TRPMs shall be removed by a method that does not materially damage the surface or texture of the pavement.
- Non-removable temporary lane markings will be permitted on pavements within the Project limits that will not be incorporated into the final pavement surface. Removable pavement markings are required at all other locations. Only upon the approval of the Mobility Authority, paint may be

permitted if the manufacturer’s specifications for removable pavement marking cannot be met because of temperature conditions. If paint is used as an interim pavement marking until the fixed epoxy pavement markings are placed, an application of water-based traffic marking paint may be used.

- All applicable existing pavement markings shall be renewed, as determined by the Mobility Authority, and maintained throughout the duration of the Project.
- All conflicting pavement markings shall be properly removed or covered, including lane lines in transition areas and improper colors. Removal of existing pavement markings shall be performed in a manner that minimizes ‘ghosting’, and shall utilize proven work methods to minimize damage to the pavement surface.
- Lane lines and pavement edges through transition and alignment change areas shall be marked with solid lines and shall be supplemented with TRPMs. Transition and alignment change areas include lane closure tapers, sharp curves, and shifts onto temporary roadways.

22.6.4 Lighting

The DB Contractor shall maintain street lighting by means of in-place lights, newly constructed lights, or a combination thereof, except as otherwise authorized by the Mobility Authority. Areas not currently illuminated may require temporary illumination due to traffic control detouring.

22.6.5 Signals

The DB Contractor shall make arrangements to transfer control of all existing signals within the Project limits from the appropriate Government Entity to the DB Contractor. The appropriate time for this transfer may vary from signal-to-signal based on construction phasing and will be done at a time to be determined by the Resident Engineer. The DB Contractor shall be responsible for maintenance of all existing signals transferred to the DB Contractor, temporary signals, and new permanent signals within the Project limits until final acceptance of each signal by the appropriate Governmental Entity.

Corridor Progression Plan. The DB Contractor shall maintain signal timing for all signals within its control in a manner that provides for progression of traffic throughout the corridor. A corridor progression plan and the timing for each individual signal shall be provided to the Mobility Authority for comment. If there are signals within the Project limits that are not within the DB Contractor’s control, the DB Contractor is responsible for getting the signal timing from the appropriate Government Entity to incorporate into the corridor progression plan. All comments on the corridor progression plan must be resolved to the satisfaction of the Mobility Authority. Signals that are determined by the Mobility Authority to have a reduced level of service caused by the DB Contractor’s inability to promptly adjust and maintain signal timing throughout the corridor will be subject to the Lane Assessment Fees shown in **Table 22-7**.

22.7 Miscellaneous

22.7.1 MOT Compliance, Suspension, and Liquidated Damages

Failure To Comply. The Mobility Authority may suspend all or part of the DB Contractor's operations for failure to comply with the RFC MOT Plan and MOT details, or failure to correct unsafe traffic conditions within 24 hours after such notification is given to the DB Contractor. If the DB Contractor does not take appropriate action to bring the deficient MOT into compliance or to correct the unsafe traffic conditions, the Mobility Authority may proceed with the corrective action using its own forces, and deduct such costs from the moneys owed the DB Contractor. If the DB Contractor's operations are suspended, the normal assessment of Contract Document time will not cease for the period required for correction of these unsafe conditions and MOT deficiencies.

Suspension and Liquidated Damages. The DB Contractor shall not be relieved of the responsibility to provide MOT safety to the traveling public while the Project is under full or partial suspension. If such suspension is due to the DB Contractor's failure to comply with this Technical Provision 22 or while the Contract Documents are under Liquidated Damages, the DB Contractor shall continue to manage and implement the MOT Plan.

22.7.2 Emergency Response

Prevention, Mitigation, and Notice. If an emergency occurs that affects the safety or protection of persons, the Project, or the property at the site or adjacent thereto, the DB Contractor shall immediately act to prevent and mitigate the threatened damage, injury, or loss. If the DB Contractor believes that such an emergency or damage has caused any significant change in the Project or variation from the Contract Documents, the DB Contractor shall give the Mobility Authority written notice within 5 Business Days of such occurrence.

Response Assistance. The DB Contractor shall cooperate with law enforcement and emergency response agencies in their response to emergencies in and around the Project, including those on the roadways and detours open to public traffic and those within the construction Work area. The DB Contractor shall help implement these agencies' preapproved response plan for accidents, fires, hazardous substance spills, or other emergency events along the Project. In an emergency, the DB Contractor shall make personnel and equipment available at the direction of law enforcement or emergency response personnel in response to reasonable requests to protect public safety. The DB Contractor shall cooperate with law enforcement personnel in all investigations of traffic accidents and incidents associated with the Project.

Combined Transportation Emergency & Communications Center (CTECC). The DB Contractor shall provide CTECC with the e-mail addresses and phone numbers for the Traffic Control Engineer, all Traffic Control Supervisors, all courtesy patrol drivers, and the responsible person for traffic signal maintenance. The DB Contractor is expected to respond in a timely manner to CTECC calls and e-mails related to issues within the Project limits. If the DB Contractor does not respond in a timely manner to a CTECC incident and this incident results in travel delays (i.e., debris blocking a lane, flashing signal), the DB Contractor

will be assessed the applicable lane rental fees and Liquidated Damages shown in **Table 22-2** through **Table 22-5**.

Access Routes. The DB Contractor shall work with emergency service providers to address concerns about emergency access to the highway corridor. The DB Contractor shall identify for law enforcement and emergency response agencies specific routes for emergency access as agreed to by the law enforcement and emergency response agencies, the Mobility Authority, and the DB Contractor. These may include, but are not limited to, openings in barriers, median openings, gates, emergency use of the DB Contractor's haul routes, and temporary graded roadways. The DB Contractor shall identify the locations of these emergency access points and routes in the MOT Plan.

Weekly Access Notifications. Except during periods of authorized Work suspensions, the DB Contractor shall notify the Mobility Authority, the Texas Department of Public Safety, local and county agencies of the access routes to and through the construction corridor. The DB Contractor shall notify emergency service providers of routes that can be used by vehicles responding to emergencies on the construction site and on the traffic lanes open to the public, as well as any major changes to the maintenance of traffic plans and construction sequencing. These written notifications shall be provided to the contact persons identified in the Community Relations Program (CRP) no later than noon on Friday of each week, for the following week's activities.

Weekly Meetings. The DB Contractor shall meet weekly with representatives of the Texas Department of Public Safety, the local Police and Fire Departments, all Emergency Management Services (EMS), County Sheriff's Office and the Mobility Authority to coordinate emergency service response and access.

Contact Notifications. Within 20 Business Days of NTP 1, the DB Contractor shall notify the Mobility Authority of the names, pager numbers, and all telephone numbers (business, residential, and cellular) of its personnel to contact in case of an emergency along the Project. This contact list shall be updated if there is any change in the contact information.

Emergency Response Plan. An Emergency Response Plan, complete with affected agencies (along with contact persons and telephone numbers) shall be included in the CRP.

22.7.3 MOT Safety

Excavations and Other Hazards. Open unprotected excavation adjacent to the existing pavement will not be permitted. The DB Contractor must provide protective devices necessary to protect traffic from excavations, drop-offs, falling objects, splatter, or other hazards that may exist during construction.

Vehicle Access. Access to or from any public road or at-grade crossing of any public road will not be permitted for the DB Contractor's equipment, material deliveries, the hauling of excavated materials of any kind, or employees' private vehicles, except at in-place public road intersections or at locations approved by the Mobility Authority.

Parking. The DB Contractor, its Subcontractors, and its suppliers must not park vehicles or construction equipment so as to obstruct any traffic control device. Workers may park their private vehicles within the Project limits only at designated sites, indicated by the DB Contractor and approved by the Mobility Authority.

Storage. The DB Contractor must not store materials or equipment within 30 feet of through traffic unless approved by the Mobility Authority. If such storage is so approved, the DB Contractor must provide barricades or barriers, as directed by the Mobility Authority, to warn drivers and protect traffic.

Restricted Shoulder Use. The use of shoulders for temporary handling of traffic is allowed provided that a 2-foot minimum distance from the toe of barrier to the edge of travel lane is maintained. If the DB Contractor wishes to use segments of the shoulders for temporary traffic lanes, the DB Contractor shall obtain approval from the Mobility Authority and TxDOT, and shall be responsible for any additional pavement structure required to obtain such approval.

Vehicle Warning Lights. All mobile equipment of the DB Contractor, Subcontractors, and Suppliers operating on the Project shall be equipped with operable warning lights that meet the appropriate requirements of the specifications of the Society of Automotive Engineers (SAE). The SAE requirements are:

360 degree rotating lights:	SAE Specification J845
Flashing lights:	SAE Specification J595
Flashing strobe lights:	SAE Specification J1318

22.7.4 Courtesy Patrol

The DB Contractor shall operate a courtesy patrol, providing all required personnel, materials, equipment, facilities, and incidentals. The courtesy patrols' main function is to assist stranded motorists and provide traffic control. The Traffic Control Engineer (TCE) shall manage the program.

Operation Times. Except during periods of Project suspension authorized by the Mobility Authority, two courtesy patrol vehicles shall operate each work day during morning (6 AM to 9 AM) and evening peak hours (3 PM to 8 PM) from NTP 2 until Substantial Completion. The actual working hours of the vehicle operators may extend beyond the peak hours depending on when an incident occurs and how long it takes to resolve.

Vehicles. The DB Contractor shall provide a clean, undamaged truck sufficiently marked as a courtesy patrol. The vehicle shall be equipped with cellular service and web access via smart phone or other portable electronic device for the courtesy patrol operators and stranded motorists to use. The vehicle shall also have arrow boards, changeable message boards, and/or attenuators, as deemed necessary, for protection of the courtesy patrol operators during support operations.

Operators. The DB Contractor shall ensure the drivers chosen for this service have had a criminal background and motor vehicle license check. The drivers shall present a consistent, clean, professional look and be courteous to the public at all times.

Contact Information. The Mobility Authority shall have the ability to report incidents on the Project directly to the courtesy patrol. The TCE shall provide the Mobility Authority with the mobile phone number for each courtesy patrol driver and a weekly schedule detailing when each courtesy patrol driver is working.

Duties. Specific duties include:

- Removing disabled vehicles from travel lanes; arrange for a local towing company to tow vehicles when necessary.
- Transporting drivers and passengers to locations within 5 miles of the Project.
- Making local emergency telephone calls for stranded motorists.
- Reporting issues of public safety, such as a defective PCMS, any dangerous traffic condition, and any traffic incidents to the TCS.
- Notifying the Texas Department of Public Safety of unattended vehicles.
- Providing fuel, water, and other provisions to facilitate the quickest removal of vehicle.
- Providing support in changing tires as needed.

Reporting. The Traffic Control Engineer shall report monthly the numbers, types, and times of day of the courtesy patrol assistance to the Mobility Authority. Existing traffic volumes and delays during peak hours within the corridor dictate the use of two courtesy patrol vehicles to reduce response time. During the course of the project as new roadway sections are opened the traffic conditions may change. The Mobility Authority will use the monthly reporting numbers to determine (at the Mobility Authority's sole discretion) if the DB Contractor can reduce the number of courtesy vehicles or operating hours as the project progresses.

22.8 Submittals

Table 22-9: Submittals to Mobility Authority

Submittals	Submittal Schedule	Mobility Authority Action	Reference Section
Maintenance of Traffic (MOT) Plan	As part of The Preliminary (30%) Design Submittal	Review and Acceptance	22.2.1
MOT Plan Revisions	10 Business Days prior to implementation of the revised MOT Plan	Review and Comment	22.2.1
Traffic Control & Sequencing Plans	As part of MOT	Acceptance	22.2.2.1
Traffic Analysis Tech Memo	As needed	Review	22.3.1
Traffic Control Supervisor Schedule	Weekly	Information	22.4.3.1
Project MOT Diary and Traffic Control Device Installation Records	Regular basis	Information	22.4.3.2
MOT Task Force Meeting Minutes	5 Business Days of the meeting	Information	22.4.5
List of Qualified Flaggers	5 days prior to the first operation requiring flaggers	Information	22.5.1
Contingency plan for reopening closed roadways, intersections, or ramps	3 Business Days prior to closing the roadway, intersection, or ramp	Review and Comments	22.5.3
Letter of Notice	6 weeks prior to removing crossing access	Information	22.5.3
Lane Closure Notice	2 and/or 7 days prior to lane closure	Approval	22.5.4
Traffic Switching Plan	5 Business Days before switching traffic	Review and Comment	22.5.5
Corridor Progression Plan	As requested	Review and Comment	22.6.5

23.0 CONSTRUCTION

The DB Contractor shall be responsible for constructing the Project in accordance with the requirements identified in this *Technical Provision 23* and shall be responsible for the quality of the construction Work effort on the Project. Project quality will be enhanced through the daily efforts of all the workers involved with the construction effort in accordance with the Construction Quality Management Plan (CQMP) described in *Technical Provision 2*.

23.1 Construction Specifications

Unless otherwise specified in the Contract Documents, Project construction shall be governed by the TxDOT *Standard Specifications for Construction and Maintenance of Highways, Streets, and Bridges*, adopted by TxDOT in November 2014 and comply with the policies, standards, guidelines, and *Technical Provisions* established by the Mobility Authority, TxDOT, and AASHTO.

23.1.1 Specific Specification Modifications

The following section provides specific modifications to the TxDOT *Standard Specifications for Construction and Maintenance of Highways, Streets, and Bridges*, adopted by TxDOT in November 2014 to be used on this Project.

23.1.1.1 Clearing and Grubbing – TxDOT Standard Spec Item 100

The DB Contractor shall remove only those trees necessary to be removed to construct this Project. All other trees shall be marked and protected from damage during construction. Existing trees to be preserved are identified in *Exhibit C – Attachment 10-1 – 183 North Mobility Project Aesthetic Design Guide*.

The DB Contractor shall take special care to preserve existing trees, shrubs, and other vegetation designated to remain. This shall include careful grading operations, slight adjustments of slopes, and placing protective fence at trees and boundaries of designated preservation areas as specified in *Exhibit C – Attachment 10-1 – 183 North Mobility Project Aesthetic Design Guide*.

No open burning will be allowed on this Project.

23.1.1.2 Building Removal – TxDOT Standard Spec Item 100

See *Technical Provision 7*.

23.1.1.3 *Excavation and Embankment – TxDOT Standard Spec Items 110 and Item 132*

The DB Contractor shall use disks, plows, graders or other equipment to blend and mix suitable grading soils to produce uniformity in soil texture, moisture content and density. Rollers shall be used to compact the embankment materials in totality (area, layers, etc.). The type of rollers(s) used for compaction shall be sufficient to meet the density requirements, as specified. The use of truck, carryall, scrapers, tractors, tractor wagons, or other haulage equipment shall not be considered in lieu of the specified compaction equipment. Construction traffic from such hauling equipment shall be distributed uniformly over the entire embankment to the maximum extent possible.

23.1.1.4 *Topsoil – TxDOT Standard Spec Item 160*

No sandy loam allowed unless approved by the Resident Engineer.

23.1.1.5 *Crushed Coarse Concrete Aggregate – TxDOT Standard Spec Item 421*

To eliminate the possibility of iron ore stains, all concrete mix designs used on the project shall have crushed coarse aggregate.

23.1.2 *Materials on Site*

The DB Contractor may use materials such as stone, gravel, sand, or other materials found in construction excavations within the Project corridor if such material meets the requirements of the Contract Documents, the Governmental Approvals and applicable Law. In order to reuse these existing materials, the DB Contractor shall hire an independent lab, approved by the Mobility Authority in writing, to perform independent material tests to ensure that the material is in compliance with the foregoing specifications and suitable for the intended use. The DB Contractor shall submit the testing results to the Mobility Authority for review and approval prior to materials being incorporated into the Project.

Material that is excavated and does not meet specifications for the Project shall be removed as excess material from the Final ROW and disposed of offsite by the DB Contractor in accordance with federal, state and local requirements. All pavement removals that are not incorporated into the Work shall be disposed of by the DB Contractor outside the Final ROW in accordance with the TxDOT specifications.

Prior to the disposal of any excess materials the DB Contractor shall submit copies of all required state, county, and local permits to the Mobility Authority.

23.1.3 *Stockpiles*

Stockpile and laydown locations are to be approved by the Mobility Authority. The DB Contractor shall submit to the Mobility Authority, for approval, plans for safe ingress and egress and site layout for each stockpile location it wishes to utilize. Each location shall include SW3P and dust control and must be

returned to as good or better condition after use including; cleaning, placing new topsoil and seeding, and repair/replacement of any damaged trees or vegetation. If parking or material placed at the site impact sight distance, corrective measures must be taken.

23.1.4 Foundation Load Tests

The DB Contractor will be responsible to furnish the jacking equipment, suitable jacking beams, and displacement indicators for performing test loading on piles or drilled shafts when needed on the Project.

23.2 House Keeping

General. Throughout all phases of construction, including Project suspension, and until Final Acceptance, the DB Contractor shall keep the Final ROW and the site clean and free from rubbish and debris. Other materials on the site, such as forms, containers, construction materials, etc., will be kept neat and organized. The DB Contractor shall keep all Work areas and Final ROW clear of potential pollution causing materials or provide appropriate controls during temporary accumulation, including, but not limited to concrete washout boxes or lined berms, Hazardous Materials storage and petroleum storage area containment systems, and prevention of excessive accumulation of flammable debris or construction wastes.

Dust Control. The DB Contractor shall abate dust nuisance by cleaning, sweeping, and sprinkling with water or other means as necessary and as directed by the Mobility Authority.

Haul Routes. The DB Contractor shall prevent spillage on haul routes. The DB Contractor shall remove any such spillage immediately and the area shall be cleaned.

Sweeping & Mud Control. The DB Contractor shall furnish and have on-site at all times an operable self-loading motor sweeper with spray nozzles and a vacuum bag. All paved areas within the Project limits shall be kept clean and free of debris to the satisfaction of the Resident Engineer. The use of water resulting in mud on streets and paved areas will not be permitted as a substitute for sweeping.

Air Quality. The DB Contractor shall not discharge smoke, dust, or any other air contaminants into the atmosphere in such quantity as will violate applicable Law or Governmental Approvals or will be a nuisance to adjoining property.

23.2.1 Protection of Surface Waters and Flood Plains

General. The DB Contractor shall keep construction material away from drainage structures, creeks, flood plain areas, flood control channels, rivers, and any other waterways. The DB Contractor shall not allow lumber, blocking, chips, loose piles, rubbish or contaminants of any nature to be deposited in the above mentioned waterways.

Cost and Schedule. The DB Contractor's removal and disposal of such items found in the Project waterways shall be at no additional cost to the Mobility Authority. The DB Contractor shall not be entitled to a time extension in connection therewith.

23.2.2 Drainage Facilities

The DB Contractor shall maintain positive drainage for the duration of the Project. This Work is the sole responsibility of the DB Contractor. Construct temporary and permanent drainage systems prior to the placement of temporary pavement, when possible, but absolutely prior to the placement of permanent pavement. The DB Contractor shall be responsible for any items associated with the temporary/interim drainage and all related maintenance. Temporary Concrete Safety Barriers shall have the required drainage slots and be maintained to allow un-obstructed flow of the drainage slots. The DB Contractor is responsible for the adequacy of any temporary/permanent drainage features installed.

23.2.3 Maintenance of Right-of-Way

Throughout all phases of construction, including suspension of the Work, and until Final Acceptance of the Project, the DB Contractor shall keep the Final ROW and work site clean and free from rubbish and debris.

23.2.4 Protection and Restoration of Property and Landscape

Fence. Where present, the DB Contractor shall keep the ROW fence closed up, except during work hours, by means of in-place fence, newly constructed fence, temporary fence (at the DB Contractor's expense), or a combination thereof.

Final ROW and/or access control fencing required to protect private property and livestock shall be installed in accordance with the terms of the Contract Documents.

Property Markers. Public and private property and landscape shall be preserved at all times. Land monuments and property markers shall not be moved, disturbed or damaged until the DB Contractor's Registered Professional Land Surveyor (RPLS) or Licensed State Land Surveyor (LSLS) has witnessed or referenced their location.

Access. The DB Contractor shall maintain access for property owners to their property at all times during construction. Exceptions to this must be coordinated by the DB Contractor with the property owner. Use of temporary pavement for temporary access is allowed provided that the temporary pavement design is approved in accordance with *Technical Provision 20*. Reclaimed asphalt pavement (RAP) is not allowed to be used as temporary pavement. Temporary pavement shall be removed upon reinstatement of permanent access.

Landscaping and Irrigation Systems. The DB Contractor shall maintain existing landscaping and irrigation system as necessary to keep landscaping in good condition and the irrigation system operational during construction. Landscaping damaged during construction shall be repaired and irrigation lines damaged

during construction shall be repaired. Relocate and reconnect any valves or devices in conflict with construction.

Cost and Schedule. The DB Contractor is responsible for damage or injury to public or private property resulting from any act, omission, neglect, or misconduct in the method of executing the Project, defective Work or materials, or nonperformance of the Contract Documents. The DB Contractor shall restore any damaged or injured property to a condition equal or better than existing before the damage or injury occurred. The repair, restoration, rebuilding, or making good such damage or injury shall be at no additional cost to the Mobility Authority and the DB Contractor shall not be entitled to a time extension in connection therewith.

23.2.5 Pedestrian Access & Recreational Trails

The DB Contractor shall maintain pedestrian access on all designated pedestrian crossings and/or recreational trails where applicable. Temporary closure of pedestrian crossings and trails (if any) will require prior approval of the Mobility Authority. American with Disability Act (ADA)-accessible detours for pedestrians and detours for cyclists shall be provided with consideration for safety and minimum path for the respective modes. Detours shall include appropriate directional signage.

23.3 Construction Documentation

General. The DB Contractor shall maintain, in a secure place at the construction field office, one record copy of all drawings, specifications, addenda, amendments, Change Orders, material test reports, inspectors reports, RFIs, Nonconformance Reports, written interpretations and clarifications, in good order and annotated to show changes made during construction. These documents, together with all approved samples and approved shop drawings shall be available at all times to the Mobility Authority.

Quality Documentation. Quality records documenting all operations, inspections, activities and tests performed, including those activities performed by Subcontractors shall be maintained in accordance with Technical Provision 2. The DB Contractor shall make all quality records immediately available to the Mobility Authority for review. The DB Contractor shall provide the Mobility Authority with a copy of any and all quality records when requested.

23.4 Construction Operations

General. The DB Contractor shall conduct its construction operations in a manner and sequence that ensures the least interference with traffic, with due regard to the location of detours and provisions for handling traffic and for maintaining access to properties. If the DB Contractor begins Work in an area and the traffic impacts are such that the opening of that roadway section is essential to public convenience, the Mobility Authority may require the DB Contractor to finish that particular section before starting construction on any additional sections. The DB Contractor shall maintain a minimum of 16 feet 6 inches

vertical clearance at all times during construction over main lanes of US 183 and Loop 1, unless otherwise approved by the Mobility Authority.

Haul Routes. The DB Contractor shall use only TxDOT-maintained roadways for haul routes. Use of local roads (city or county) is not allowed unless approved by the Mobility Authority. The DB Contractor must submit a hauling plan and receive approval of the hauling plan from the Mobility Authority before hauling operations begin. The hauling plan shall consist of an aerial map showing the roads to be used for the haul route, a description of the materials being hauled, ingress and egress locations to the construction site, and a statement that the hauling of these materials will be in accordance with all loading and weight restrictions required by all State authorities (and local authorities, if applicable) on the roads being used for the haul route.

Backup Alarms. The DB Contractor shall have directional, broadband backup alarms on all construction equipment requiring a backup alarm being used on this Project. Non-broadband backup alarms are not allowed. For the hours between 9:00 pm and 5:00am, utilize a non-intrusive, self-adjusting noise level reverse signal alarm. This is not applicable to hotmix operations.

Night Work. Night Work is any Work performed between 7:00 p.m. and 7:00 a.m. The DB Contractor shall provide the Mobility Authority written notice 10 business days in advance of the first Night Work (as defined below) on the Project. The need for on-going Night Work will be detailed in the rolling 3-week inspection notice provided to the Mobility Authority each week. If Night Work operations are terminated for a continuous period in excess of 30 days, the DB Contractor shall provide the Mobility Authority written notice 10 business days in advance of resuming Night Work.

Night Work will only be allowed if adequate lighting is provided for performing satisfactory inspection and construction operations. Night Work will not be allowed if the DB Contractor does not provide a night superintendent on-site during all Night Work. Night Work will not be allowed if the DB Contractor does not provide the Material Acceptance staff with sufficient notice to schedule inspection and testing personnel. The DB Contractor shall be responsible for coordinating and seeking any necessary approval from local municipalities within the Project corridor for all Night Work.

During Night Work, the DB Contractor shall minimize the following:

- Noise (particularly when working near residential areas).
- Construction spillover light onto existing roadways and outside of the Final ROW.

Failure to provide the Mobility Authority with adequate notice as specified above may result in the Mobility Authority withholding the DB Contractor's development management portion of the applicable progress payments. Withheld payments will be released following compliance with the aforementioned notification requirement.

23.5 Surveying and Construction Staking

23.5.1 General

The DB Contractor shall be responsible for all control surveys, topographic surveys, construction staking, and all surveying Work necessary to complete the Project and to produce accurate Record Drawings. The DB Contractor shall be responsible for all surveying necessary to complete the Work.

23.5.2 Reference Documents

Survey Control. The Mobility Authority has provided initial topographic survey and survey control data for the Project. Provided primary and secondary survey horizontal and vertical controls were established based on U.S customary units system of measurement (U.S. Survey Feet). Survey coordinates were based on the Texas State Plane Coordinate System, Texas Central Zone, NAD 83 (**NON-HARN**) with a surface adjustment factor of 1.00011. All elevations are based in North American Vertical Datum 1988 (NAVD 88), established with digital levels.

The DB Contractor shall establish and maintain a thorough and redundant survey control network for the construction of the Project. The DB Contractor shall utilize the primary and secondary survey control information in *Exhibit D – Item 6 – Survey Data*, consisting of descriptions of primary control points used for the horizontal and vertical control, and descriptions of additional primary control points for the Project length. All control points shall be described by reference to the Project alignment and the coordinate system and elevation datum used by the Project.

Aerial Mapping. The Mobility Authority has provided low-level aerial mapping, planimetrics, Digital Terrain Model (DTM), and digital images for the DB Contractor's use, as included in *Exhibit D – Item 6 – Survey Data*. The DB Contractor shall review existing survey data and update or extend survey and mapping data as necessary. The DB Contractor shall be responsible for the final precision, accuracy, and comprehensiveness of all survey and mapping Work. All calculations, surveying, and measuring required for setting and maintaining the necessary lines and grades for the Project shall be the DB Contractor's responsibility.

23.5.3 Performance Requirements

General. The DB Contractor is responsible for the accuracy of content and completeness of all survey information used in the design and construction of the Project. The Mobility Authority does not warrant the accuracy of the provided initial survey information.

The DB Contractor shall install and maintain all survey control monumentation and Final ROW monumentation in accordance with TxDOT specifications throughout the Work at the DB Contractor's expense. The DB Contractor shall incorporate all supplemental and additional mapping or ground topographic mapping needed to meet the Project requirements into the base mapping files. New mapping

shall be shown on all survey, engineering, and ROW products referencing the base map. Supplemental and additional mapping or ground topographic mapping shall include, but not be limited to, the following conditions: new improvements, changes to improvements, areas obscured by vegetation or structures, areas outside the current mapping, areas requiring more accurate topographic information, and changes in the ROW configuration or alignment.

If requested, the DB Contractor will make available to the SI electronic file copies of available survey and mapping data necessary for the SI to complete its work.

The meaning of words and terms used in this provision shall be as listed in *Definitions of Surveying and Associated Terms*, current edition, published by the American Congress on Surveying and Mapping and the American Society of Civil Engineers. All field survey Work and survey activities required for this Project shall be performed in conformance with the TxDOT surveying and mapping guidelines and procedures, as applicable.

The Mobility Authority may spot-check the DB Contractor's surveying. These spot-checks will not change the requirements for normal checking by the DB Contractor.

Right of Entry. The DB Contractor shall secure written permission prior to entering any private property outside the Project ROW. It shall be the DB Contractor's sole responsibility to negotiate this permission. The DB Contractor shall be responsible for any and all damages and claims resulting from that ingress. Proper documentation of right-of-entry shall be maintained at all times by the DB Contractor

Standards and Units. The DB Contractor shall ensure that all surveying conforms to the TxDOT Survey Manual, the General Rules of Procedures and Practices of the Texas Board of Professional Land Surveying. The DB Contractor shall ensure that any person in charge of a survey field party is proficient in the technical aspects of surveying.

Survey Control Requirements. The DB Contractor shall base all additional horizontal and vertical control on control provided by the Mobility Authority.

The DB Contractor shall submit a statement (Validation of Survey Control Accuracy) indicating all Mobility Authority provided horizontal and vertical survey control has been field checked and the control has been determined to be accurate within the tolerances specified in the TxDOT *Survey Manual Section 3.1 (Horizontal Control Surveys) and 3.2 (Vertical Control Surveys)*. The DB Contractor shall not begin any field activities or advance design until it has verified or corrected and verified the Mobility Authority provided horizontal and vertical control. If discrepancies are found, the DB Contractor shall notify the Mobility Authority both verbally and in writing and shall work with the Mobility Authority to rectify such discrepancies in order to be able to provide the Validation of Survey Control Accuracy. The DB Contractor shall include, along with the Validation of Survey Control Accuracy, all survey information used to verify control.

The DB Contractor shall establish and maintain additional survey control, as needed, and Project ROW monumentation throughout the duration of the Project. The DB Contractor shall tie any additional horizontal and vertical control for the Project to the Mobility Authority-supplied primary control network. If the DB Contractor chooses to use GPS methods, the DB Contractor shall meet the accuracy of the appropriate level of survey as defined in the TxDOT GPS User's Manual and shall utilize the primary control provided by the Mobility Authority.

The DB Contractor shall establish and maintain a permanent survey control network. The control network should consist of, at a minimum, monuments set in intervisible pairs at spacing of no greater than three miles.

Monuments shall be TxDOT bronze survey markers installed in concrete and marked as directed by the TxDOT Survey Manual. The DB Contractor shall replace all existing survey monuments and control points disturbed or destroyed during execution of the Work. The DB Contractor shall make all survey computations and observations necessary to establish the exact position of all other control points based on the primary control provided by the Mobility Authority.

The DB Contractor shall deliver to the Mobility Authority a listing of all survey control coordinate values, original computations, survey notes, and other records, including GPS observations and analysis made by the DB Contractor upon request.

Survey Records. The DB Contractor shall provide the Mobility Authority copies of all calculations and staking data prior to, or within three days of, performing any construction staking. Detailed survey records shall be maintained, including a description of the Work performed on each shift, the methods utilized, and the control points used. The record shall be adequate to allow the survey to be reproduced. A copy of each day's record shall be provided to the Mobility Authority upon request.

23.6 Video Inspection of Drainage System

Prior to Substantial Completion, the DB Contractor shall television film, at the DB Contractor's expense, all storm sewers pipes, box culverts, inlets and manholes (i.e., all drainage features impacted physically or by receiving increased flows), except where visual inspection is sufficient as determined by the Mobility Authority (i.e., drainage features visible from the access point), and shall submit this film to the Mobility Authority for review and incorporation into the punch list.

The DB Contractor is encouraged to perform preliminary video inspection so any items requiring correction may be identified and addressed prior to any paving activities.

The DB Contractor shall provide the Mobility Authority a high-quality video DVD and text report that provides at a minimum:

- Line designation.

- Starting and ending location (i.e., from inlet x to inlet y).
- A method of stationing that makes it clear where the camera is in the line at any point during the video.

Use a camera with lighting suitable to allow a clear picture of the entire periphery of the pipe. Use equipment to move the camera through the pipe that will not obstruct the camera's view or interfere with proper documentation of the pipe's condition.

Any locations that require corrective action (i.e., removal of formwork, clearing a blockage) will require a follow-up television inspection to be performed at the DB Contractor's expense to verify that the issue has been corrected. All locations requiring corrective action must be addressed to the satisfaction of the Mobility Authority prior to Final Acceptance.

All Work related to the video inspection of the storm sewer and any corrective action needed as a result of the video findings shall be considered subsidiary to the various storm sewer bid items.

23.7 Project Segments

The Project may be divided into discrete segments for the purposes of having the DB Contractor progress the Construction Work effort in phases.

The exact termination points of the segment limits shall be determined by the DB Contractor and submitted to the Mobility Authority for concurrence. Each segment shall provide a functional segment of roadway to facilitate safe traffic movements with intersecting roads and streets including construction of access roads, general purpose lanes, ramps, and interchanges. Ancillary items of the Project including, but not limited to, earthwork, drainage facilities, and Utility Adjustments shall extend past segment limits as required to allow completion of each segment to the agreed-upon limits while providing full functionality for these ancillary items. Traffic control devices at ends of segments that do not connect to previously completed segments shall be in accordance with applicable TMUTCD standards.

23.7.1 Design Requirements

General. The requirements contained in the *Technical Provisions* shall apply to each segment of the Project to the extent that plan sets for each segment shall be prepared and submitted as a unit after issuance of NTP 1. The DB Contractor shall take appropriate steps to ensure that the design and construction interface between the segments is properly coordinated, approved and abides by the DB Contractor's Quality Management Plans (*QMPs*) as defined in *Technical Provision 2*.

Sub-Segments. The DB Contractor may subdivide each segment into sub-segments for the purposes of completing the design. The DB Contractor, with the Mobility Authority's prior approval, may make submittals for these sub-segments and shall take appropriate steps to ensure that the design and construction

interface between the sub-segments is properly coordinated, approved and abides by the DB Contractor's QMPs as defined in Technical Provision 2.

23.7.2 Environmental Requirements

The requirements contained in Technical Provision 9 shall apply to each segment of the Project. In the event that environmental mitigation sites are to be established for mitigating impacts to multiple segments, the DB Contractor's ECM shall be responsible for ensuring that the schedule for establishing these mitigation sites are in accordance with the DB Contractor's QMPs as defined in Technical Provision 2 and all applicable Environmental Approvals.

23.7.3 Utilities

The requirements contained in Technical Provision 8 shall apply to each segment of the Project to the extent that Utility Adjustment plan sets for each segment are being prepared. The DB Contractor shall take appropriate steps to ensure that the design and construction interface between the segments is properly coordinated, approved and abides by the DB Contractor's QMPs as defined in Technical Provision 2.

23.7.4 Right-of-Way

The requirements contained in Technical Provision 7 shall apply to each segment of the Project as deemed appropriate by the DB Contractor, in consultation with the Mobility Authority, for the purposes of enhancing coordination with affected property owners.

23.7.5 Project Schedule and Schedule of Values

The requirements contained in Technical Provision 5 shall apply to each segment of the Project to the extent that each segment shall be clearly indicated on the Project Schedule and the cost allocation by segment is provided in the Schedule of Values.

23.8 Submittals

Table 23-1: Submittals to Mobility Authority

Submittals	Submittal Schedule	Mobility Authority Action	Reference Section
Materials-on-Site Testing	As needed	Review and Approval	23.1.2
Stockpile location	As needed	Approval	23.1.3
Hauling Plan	Before hauling operations begin	Approval	23.4
Night Work Notice	10 business days in advance of the first Night Work	Information	23.4
Validation of Survey Control Accuracy	Prior to beginning Work	Information	23.5
Calculations and Staking Data	Prior to performing any construction staking	Information	23.5
Storm Water Television Film	Prior to Substantial Completion	Review	23.6

24.0 MAINTENANCE

The DB Contractor shall be responsible for maintaining the Project for the term of the DBA in accordance with the requirements identified in this *Technical Provision 24*. Limits of maintenance is shown in *Exhibit D – Item 1 – General*.

24.1 General Requirements

The DB Contractor maintenance of all roadway surfaces and facilities within the Project ROW will begin when Project barricades are placed (sometime between NTP 1 and the start of construction) anywhere on the Project through Final Acceptance and during any suspension of the Project.

The DB Contractor shall furnish all labor, materials, equipment, and necessary services (such as highway safety controls) in connection with the general maintenance during construction.

The DB Contractor's responsibilities shall include repair required due to third party damage.

Maintenance to be performed by the DB Contractor shall include:

- Base and subgrade repair on travel lanes and shoulders.
- Pavement surface repair on travel lanes and shoulders.
- Mowing & vegetation control (3 cycles yearly, as directed by the Mobility Authority).
- On call spot mowing as requested.
- Litter removal in advance of mowing and litter disposal (min 2 cycles per month).
- Debris and animal removal daily and on call litter removal and disposal as requested.
- Street sweeping (general purpose lanes, ramps, general purpose lanes) (2 cycles per month or as directed by the Mobility Authority for special events).
- Removal of any graffiti from fixtures, wing walls, bridge structures, etc. (within 24 hours).
- Erosion protections repair (ditch liners, retards, down drains, riprap, flumes, concrete mow strips, gabions, retaining walls and other erosion protection).
- Permanent and temporary drainage facilities maintenance including:
 - Culvert and storm drain silt and debris removal.
 - Detention and water quality ponds.
- Removal of illegal signs on Final ROW.
- Repair cable median barrier, guard fence, guardrail end treatment systems, & attenuators.

- Striping, buttons, and delineator repair or replacement.
- Small and large sign repair or replacement.
- Safety lighting repair or replacement.

Maintenance responsibility for mowing and vegetation control; litter removal and disposal; debris removal and disposal; and incident management for *express lanes and tolling infrastructure only* shall be handed over to the Mobility Authority's maintenance contractor upon achievement of Substantial Completion. The DB Contractor shall continue to maintain the remainder of the project until Final Acceptance.

The DB Contractor is not responsible for:

- Traffic signal repair (signal heads, LEDs, signs, detections, signal poles, timing and phasing, push buttons, pedestrian heads).
- Snow and ice removal (sanding, deicing, clearing).
- Traffic management system including repair and maintenance of dynamic message signs, cameras, to the extent such TMS equipment exists as of the date of this DB Agreement.

Previous Damage Report. The DB Contractor will not be responsible for repairing previously damaged items within the Project limits. The DB Contractor shall document the condition of the existing facility prior to taking on maintenance responsibilities. Any damage not documented will be the responsibility of the DB Contractor to correct. A Baseline Condition Report shall be submitted to the Mobility Authority and TxDOT for concurrence prior to placement of Project barricades.

Standards of Work. All Work done under this section by the DB Contractor shall be performed in conformance with the TxDOT Standards in effect for the Project. The DB Contractor shall perform the maintenance Work of the Project in a safe, reasonable, and prudent manner and shall employ good business practices and appropriate management techniques.

Mobility Authority Responsibility and Rights. The Mobility Authority reserves the right to perform such routine maintenance Work as it deems necessary with its own forces, and/or to enter into special contracts with contractors other than the DB Contractor. The Mobility Authority will oversee the DB Contractor's maintenance program as part of its QAP and will issue nonconformance reports if the maintenance efforts do not meet the requirements of the Contract Documents including PDA requirements. The Mobility Authority will provide written confirmation to the DB Contractor when the frontage road and general purpose lanes of the Project are released back to TxDOT for maintenance.

Claims for Damage from Maintenance. Any damage claims as a result of the DB Contractor's maintenance program, or lack thereof, will be forwarded to the DB Contractor for payment and processing.

The DB Contractor's maintenance shall include, but not be limited to, the elements in this *Technical Provision 24.*

24.2 General Maintenance Requirements

The DB Contractor shall prepare a Maintenance Management Plan (MMP) that describes the DB Contractor's approach for addressing the following general maintenance obligations:

Pavement and Shoulders. For the duration of the Project, as defined above, the DB Contractor shall perform all repair and maintenance Work for all roadway pavement surfaces and shoulder surfaces (both existing and new) within the Project limits. This Work shall include roadway surface patching and/or replacement, shoulder patching and/or replacement, and minimizing drop-offs throughout the Project. All provisions of this Technical Provision 24 shall apply unless the maintenance Work is deemed to be an emergency.

Signs and Guardrail. The DB Contractor shall repair downed or damaged signs, traffic control, and safety devices within 24 hours from time of damage or discovery. Damaged guardrail shall have barrels and warning signs placed immediately after discovery of the damage and the DB Contractor shall begin repairs within 72 hours and be complete no more than 10 days after the damage occurred.

Damage from Operations. The DB Contractor shall perform maintenance to mitigate any damage caused by its operations; for example, clean out sediment that has accumulated in drainage structures as a result of the DB Contractor's grading operations.

Inspection. The DB Contractor shall inspect the facility daily to maintain a properly functioning facility including signs, signals, lighting, and traffic barrier damage.

Emergencies. The DB Contractor shall provide any maintenance activities deemed necessary in response to emergency situations. See also Technical Provision 22 for detailed requirements.

Emergency Repairs. The Mobility Authority will notify the DB Contractor when action is required to address a condition that it has determined to be unsafe, and the DB Contractor must make immediate emergency repairs. However, if the DB Contractor is unavailable or unable to comply with this requirement to the Mobility Authority's satisfaction and within the time frame required by the Mobility Authority, the Mobility Authority will perform, or have performed, any necessary emergency repairs. Any such emergency repairs undertaken will not relieve the DB Contractor from the obligation to meet the maintenance requirements. If the unsafe condition is determined by the Mobility Authority to have been caused by the DB Contractor's operations, defective materials and/or workmanship, then any cost associated with the emergency repair shall be paid by the DB Contractor. In the event the DB Contractor fails to pay such cost within 30 days of receipt of notice for payment, the Mobility Authority will be entitled to recover the costs of such Work.

24.3 Limitations of Operations

Traffic Flow. Maintenance operations shall be conducted in a manner and sequence that ensures the least interference with traffic with due regard to the location of detours and provisions for handling traffic. If the opening of a particular section of the Project is essential to public convenience, the Mobility Authority may require that section to be finished before starting Work on other sections. The requirements of Technical Provision 22 apply to any DB Contractor maintenance activities.

24.4 Submittals

Table 24-1: Submittals to Mobility Authority

Submittals	Submittal Schedule	Mobility Authority Action	Reference Section
Previous Damage Report	Prior to placement of Project barricades	Concurrence	24.1
Maintenance Management Plan (MMP)	Within 30 days after NTP1	Acceptance	24.2

25.0 SAFETY PLAN

The DB Contractor shall be responsible for safety in accordance with the requirements identified in this *Technical Provision 25*. The DB Contractor shall prepare and implement a Safety Plan for the Project that is available to all personnel and fosters attitudes that are conducive to providing and maintaining a safe and healthful workplace environment.

25.1 General Requirements

Contents. The safety plan shall be prepared in accordance with the requirements of *OSHA* and contain, as a minimum, the following requirements:

- The DB Contractor shall employ a full-time, on-the-job safety manager who has a minimum of 5 years of heavy construction experience and has completed the OSHA #500 course –Trainer Course in Occupational Safety & Health Standards for the Construction Industry, no later than 30 days after issuance of NTP1.
- The safety manager shall have the authority to stop work.
- All Subcontractors shall adhere to the DB Contractor’s Safety Plan. If a Subcontractor fails to adhere to the Safety provisions, the DB Contractor shall suspend Subcontractor activities until it is in compliance. If the problem or similar problems persist, the DB Contractor shall remove the Subcontractor from the Project.
- All persons performing construction Work, as well as any nonproduction personnel, shall be supplied with and are required to wear the proper personal protective equipment for the job task they are performing. Minimum required safety equipment will consist of hardhat, safety vest, safety glasses, and appropriate footwear.
- All individuals performing Construction Work and any other persons who work on the site shall attend a project-specific safety orientation and have any additional proper training and safety orientation for the job task they are performing for the Project (confined space, fall protection, power tools, traffic control, equipment operation, etc.). The DB Contractor shall hold periodic on-site safety meetings, conduct periodic safety inspections and provide refresher training.
- The DB Contractor shall establish an employee identification system, conduct drug screening for all new hires, establish daily housekeeping and clean-up procedures, and have first-aid and medical kits readily available.

The safety plan shall also include:

- Safety and health standards to be adhered to.

- Roles and responsibilities of the safety staff.
- An emergency preparedness and incident management plan, including roles and responsibilities, emergency evacuations, communications, first responder awareness training, and field drills.
- A site security plan.
- Table of contents for safety and security periodic reporting (normally monthly).

The DB Contractor shall be responsible for coordination and compliance of the Safety Plan with the Toll System Integrator.

Weekly Meetings. The DB Contractor and its Subcontractors performing Construction Work shall, at a minimum, conduct weekly toolbox safety meetings with all field employees.

Competent Person. The DB Contractor and its Subcontractors shall ensure that a qualified competent person is provided at Work locations where required by OSHA.

Jobsite Postings. The DB Contractor and its Subcontractors shall ensure that all applicable forms (confined space permit, work permit, lockout/tagout, critical lift checklist, excavation permit, etc.) are posted at Work locations where required by the OSHA.

25.2 Submittals

Table 25-1: Submittals to Mobility Authority

Submittals	Submittal Schedule	Mobility Authority Action	Reference Section
Safety Plan	30 days prior to placement of barricades	Acceptance	25.1

26.0 SUSTAINABILITY

The DB Contractor shall be responsible for implementing sustainable practices in accordance with the requirements identified in this *Technical Provision 26*.

The Mobility Authority encourages the DB Contractor to incorporate sustainable practices into the Design-Build Work and, to this end, the DB Contractor shall use FHWA's INVEST (Infrastructure Voluntary Evaluation Sustainability Tool) web-based self-evaluation tool to measure and assess its success in accomplishing that goal. The DB Contractor shall use INVEST version 1.3 or the most recent version of INVEST at the Mobility Authority's sole discretion.

26.1 INVEST Project Type and Module

For evaluation of Project Sustainability, the DB Contractor shall employ INVEST's Project Development Module, which represents the planning, design and construction phases of a project, and the scorecard for "Extended Urban" projects provided in the INVEST tool. The DB Contractor shall include Project Work previously completed by the Mobility Authority and the DB Contractor's Work in executing Project design and construction for evaluation of Project Sustainability using INVEST Project Development criteria.

26.2 Required INVEST Achievement Level for Project

Employing the INVEST Project Development criteria, the DB Contractor shall achieve at least 30 percent of total possible points on the INVEST Extended Urban scorecards, resulting in certification at the Bronze Achievement Level.

26.3 Pre-Scoring Workshop

Within 60 days of NTP 1, the DB Contractor shall assemble an interdisciplinary staff team and shall conduct a pre-scoring workshop with the Mobility Authority to develop a preliminary assessment of which INVEST Project Development criteria can be satisfied by the Project, as well as the estimated number of associated scorecard points and the anticipated INVEST Achievement Level that the Project is likely to earn. At the pre-scoring workshop, the participants will determine the number of points for each criterion that the project would automatically be eligible for based on project requirements related to Mobility Authority, TxDOT or federal policy, and also evaluate the number of points considered to be readily attainable, meaning that earning the points would require action beyond basic requirements but that those actions would not be prohibitive.

26.3.1 Pre-Scoring Workshop Preparation

To prepare for the pre-scoring workshop, the DB Contractor shall assign interdisciplinary staff to review the INVEST website and become familiar with the Project Development criteria required by respective

staff members' disciplines and collect the appropriate information for each Project Development criterion. The DB Contractor shall develop a draft list of information needed for each Project Development criterion and collect the relevant documentation materials for specific criteria.

26.4 Reporting

Twice per year on or before July 31 and January 31 and at the completion of the Project, the DB Contractor shall submit a Sustainability Progress Report to the Mobility Authority outlining the progress of Sustainability measures implemented/utilized on the Project and assessed by the INVEST tool employing the Project Development criteria, as well as the associated number of scorecard points and INVEST Achievement Level that the Project is on track to earn.

26.5 Awards and Incentives Associated with INVEST Achievement Levels

In the event that the Project exceeds the Bronze Achievement Level (30 percent) at the completion of the Project, the DB Contractor shall be eligible for recognition associated with constructing a Silver, Gold or Platinum Level Project.

26.5.1 INVEST Silver Achievement Level Project

For attaining or exceeding the INVEST Silver Achievement Level (40 percent of possible points), the DB Contractor will be recognized with a plaque and an incentive payment of \$100,000.

26.5.2 INVEST Gold Achievement Level Project

For attaining or exceeding the INVEST Gold Achievement Level (50 percent of possible points), the DB Contractor will be recognized with a plaque and an incentive payment of \$150,000.

26.5.3 INVEST Platinum Achievement Level Project

For attaining or exceeding the INVEST Platinum Achievement Level (60 percent of possible points), the DB Contractor will be recognized with a plaque and an incentive payment of \$250,000.

Should the Project attain the INVEST Platinum Achievement Level prior to the end of the Project, the DB Contractor must continue to submit accurate reports regarding the implementation/utilization of all measures associated with the Project Development Criteria. Failure to do so will result in forfeiture of any awards and/or incentives.

26.6 Effects on Price and Schedule

All cost and schedule impacts, both direct and indirect, associated with the inclusion of any and all measures to satisfy INVEST Project Development Criteria by the DB Contractor in association with this

Technical Provision 26 are considered to be included in the DB Contractor’s Proposal and the Design-Build Price. Inclusion of any and all measures to satisfy INVEST Project Development criteria by the DB Contractor in the implementation of this DB Contract will not be allowed as a basis for any cost or time claims by the DB Contractor.

26.7 Personnel and Staffing

The DB Contractor shall assign a Sustainability Manager responsible for leading the DB Contractor’s efforts in obtaining Sustainability certification via INVEST as set forth in this *Technical Provision 26*. The Sustainability Manager must have been directly responsible for obtaining FHWA INVEST achievement levels, Envision Program awards, LEEDS certification, or similar certification on significant infrastructure projects on at least one significant infrastructure project within the past 5 years. The Sustainability Manager may be employed by a subcontractor. The duties of Sustainability Manager need not be considered equivalent to a full-time position and may be combined with another position.

26.8 Submittals

Table 26-1: Submittals to Mobility Authority

Submittals	Submittal Schedule	Mobility Authority Action	Reference Section
Sustainability Progress Report	Twice per year and at completion of the Project	For information	26.4

Central Texas Regional Mobility Authority
Technical Provisions
For
183 North Mobility Project

ATTACHMENT 5-1
WBS MINIMUM REQUIREMENTS

Table 1 represents the minimum levels of the WBS that all schedule information shall rollup to once the Project Baseline Schedule is fully developed.

The WBS in general shall conform to level structure as follows or as otherwise approved by TxDOT:

Table 1: WBS Minimum Requirements

- 1. Project
 - 1.1. Project Administration
 - 1.1.1. Mobilization
 - 1.1.1.1. Developer
 - 1.1.2. Submittals and Permitting
 - 1.1.2.1. (By Government Agency)
 - 1.1.2.1.1. (By Specific Permit/Submittal Requirement)
 - 1.1.3. Design QC and QA
 - 1.1.4. Geotech and Survey
 - 1.1.5. Community Outreach
 - 1.1.6. Bonds
 - 1.1.7. Warranties
 - 1.1.8. Insurance Premiums
 - 1.2. Right of Way Acquisition
 - 1.2.1. Acquisition by the Mobility Authority
 - 1.2.1.1. (By Parcel No.)
 - 1.2.2. Acquisition by Developer
 - 1.2.2.1. (By Parcel Number)
 - 1.3. Utility Adjustments
 - 1.3.1. Utility Coordination
 - 1.3.1.1. Administration and Planning
 - 1.3.1.1.1. Site Utility Engineering
 - 1.3.1.1.2. Conceptual Design
 - 1.3.1.2. (By Owner)
 - 1.3.1.2.1. Master Agreements
 - 1.3.1.2.2. Utility Assemblies
 - 1.3.2. Utility Relocations
 - 1.3.2.1. (By Owner)
 - 1.3.2.1.1. (By Line No.)
 - 1.4. Design
 - 1.4.1. General Activities and Field Work
 - 1.4.1.1. Design Mobilization
 - 1.4.1.2. Schematics
 - 1.4.1.3. Survey Work
 - 1.4.1.4. Geotechnical Investigations
 - 1.4.1.5. Additional Field Investigations

- 1.4.2. Develop Specifications
 - 1.4.2.1. (By Discipline)
- 1.4.3. Geotechnical Design
 - 1.4.3.1. General
 - 1.4.3.2. Earthwork Geotech
 - 1.4.3.3. Bridge Geotech
 - 1.4.3.4. Culvert Geotech
 - 1.4.3.5. Wall Geotech
 - 1.4.3.6. Pavement Borings
- 1.4.4. Pavement Design
 - 1.4.4.1. Data Analysis and Draft Report
 - 1.4.4.2. Final Design and Report
- 1.4.5. Drainage Design
 - 1.4.5.1. Hydrologic and Hydraulic Design
 - 1.4.5.2. Preliminary System Design
 - 1.4.5.3. Detailed Drainage Design
- 1.4.6. Roadway Design
 - 1.4.6.1. Alignments
 - 1.4.6.2. Earthwork
 - 1.4.6.3. Typical Sections
 - 1.4.6.4. Detailed Design
- 1.4.7. Bridge Design
 - 1.4.7.1. Establish Criteria and Procedures
 - 1.4.7.2. Bridge Layouts
 - 1.4.7.3. Substructure Design
 - 1.4.7.4. Superstructure Design
- 1.4.8. Retaining Wall Design
 - 1.4.8.1. Establish Criteria and Procedures
 - 1.4.8.2. Fill Wall Design
 - 1.4.8.3. Cut Wall Design
- 1.4.9. Traffic Management
 - 1.4.9.1. Traffic Control Development (By Phase)
- 1.4.10. Environmental Design
 - 1.4.10.1. Erosion Control/SWPPP/EPIC
 - 1.4.10.2. Noise Wall Design
- 1.4.11. Landscape and Aesthetic design
 - 1.4.11.1. Landscape Design
 - 1.4.11.2. Aesthetic Design
- 1.4.12. Electrical Design
 - 1.4.12.1. Illumination
 - 1.4.12.2. Traffic Signals

- 1.4.13. ITS and TCS Design
 - 1.4.13.1. Duct Bank System & Power Supply
 - 1.4.13.2. ITS/TCS Equipment and Structures
- 1.4.14. Signage and Marking Design
 - 1.4.14.1. Overhead Signs
 - 1.4.14.2. Small and Large Signs
 - 1.4.14.3. Pavement Markings
- 1.4.15. Design Packages
 - 1.4.15.1. Package Preparation
 - 1.4.15.2. QA/QC Review
 - 1.4.15.3. Submittal
 - 1.4.15.4. TxDOT/IE Reviews
 - 1.4.15.5. Comment Resolution
- 1.5. Construction
 - 1.5.1. Quality Management and Testing
 - 1.5.1.1. Quality Control
 - 1.5.2. Maintenance of Corridor & Courtesy Patrol
 - 1.5.3. Traffic Control and Temporary Work
 - 1.5.3.1. Barricades, Signs and Traffic Handling
 - 1.5.3.2. Erosion Control
 - 1.5.3.3. Detour Construction/Removal
 - 1.5.3.4. Portable Traffic Barrier
 - 1.5.3.5. Workzone Pavement Marking
 - 1.5.3.6. Temporary Bridges/Shoo-Flys
 - 1.5.3.7. Temporary Walls/Shoring
 - 1.5.3.8. Temporary Drainage
 - 1.5.4. Environmental Mitigation
 - 1.5.4.1. Noise Walls
 - 1.5.4.2. Wetland and Habitat Mitigation
 - 1.5.5. Hazardous Mitigation
 - 1.5.5.1. Site Assessments
 - 1.5.5.2. Remediation
 - 1.5.6. Removals
 - 1.5.6.1. Frontage Road Removals
 - 1.5.6.1.1. Building Removals
 - 1.5.6.1.2. ROW Preparation
 - 1.5.6.1.3. Roadway Removals
 - 1.5.6.1.4. Bridge Removals
 - 1.5.6.2. SUP Removals
 - 1.5.6.2.1. Building Removals
 - 1.5.6.2.2. ROW Preparation
 - 1.5.6.2.3. Roadway Removals
 - 1.5.6.2.4. Bridge Removals

- 1.5.6.3. Mainlane Removals
 - 1.5.6.3.1. Building Removals
 - 1.5.6.3.2. ROW Preparation
 - 1.5.6.3.3. Roadway Removals
 - 1.5.6.3.4. Bridge Removals
- 1.5.7. Earthwork
 - 1.5.7.1. Frontage Road Earthwork
 - 1.5.7.1.1. Topsoil Stripping and Placing
 - 1.5.7.1.2. Excavation
 - 1.5.7.1.3. Embankment
 - 1.5.7.1.4. Special Geotechnical Measures
 - 1.5.7.2. SUP Earthwork
 - 1.5.7.2.1. Topsoil Stripping and Placing
 - 1.5.7.2.2. Excavation
 - 1.5.7.2.3. Embankment
 - 1.5.7.2.4. Special Geotechnical Measures
 - 1.5.7.3. Mainlane Earthwork
 - 1.5.7.3.1. Topsoil Stripping and Placing
 - 1.5.7.3.2. Excavation
 - 1.5.7.3.3. Embankment
 - 1.5.7.3.4. Special Geotechnical Measures
- 1.5.8. Subgrade Treatment and Base
 - 1.5.8.1. Frontage Road Subgrade and Base
 - 1.5.8.1.1. Lime Treatment and Other
 - 1.5.8.1.2. Flexible Base
 - 1.5.8.2. SUP Subgrade and Base
 - 1.5.8.2.1. Lime Treatment and Other
 - 1.5.8.2.2. Flexible Base
 - 1.5.8.3. Mainlane Subgrade and Base
 - 1.5.8.3.1. Lime Treatment and Other
 - 1.5.8.3.2. Flexible Base
- 1.5.9. Drainage
 - 1.5.9.1. Frontage Road Drainage
 - 1.5.9.1.1. Culverts
 - 1.5.9.1.2. Storm Sewer
 - 1.5.9.1.3. Riprap
 - 1.5.9.2. SUP Road Drainage
 - 1.5.9.2.1. Culverts
 - 1.5.9.2.2. Storm Sewer
 - 1.5.9.2.3. Riprap
 - 1.5.9.3. Mainlane Drainage
 - 1.5.9.3.1. Culverts
 - 1.5.9.3.2. Storm Sewer
 - 1.5.9.3.3. Riprap

- 1.5.10. Pavement
 - 1.5.10.1. Frontage Road Pavement
 - 1.5.10.1.1. Asphalt Pavement
 - 1.5.10.1.2. Concrete Pavement
 - 1.5.10.1.3. Curb and Gutter
 - 1.5.10.1.4. Driveways
 - 1.5.10.1.5. Sidewalk and Median Paving
 - 1.5.10.2. SUP Paving
 - 1.5.10.2.1. Asphalt Pavement
 - 1.5.10.2.2. Concrete Pavement
 - 1.5.10.2.3. Curb and Gutter
 - 1.5.10.2.4. Driveways
 - 1.5.10.2.5. Sidewalk and Median Paving
 - 1.5.10.3. Mainlane Pavement
 - 1.5.10.3.1. Asphalt Pavement
 - 1.5.10.3.2. Concrete Pavement
 - 1.5.10.3.3. Curb and Gutter
 - 1.5.10.3.4. Driveways
 - 1.5.10.3.5. Sidewalk and Median Paving
- 1.5.11. Retaining Walls
 - 1.5.11.1. Frontage Road Retaining Walls
 - 1.5.11.1.1. Frontage Sound and Neighborhood Walls
 - 1.5.11.2. SUP Retaining Walls
 - 1.5.11.2.1. SUP Sound and Neighborhood Walls
 - 1.5.11.3. Mainlane Retaining Walls
 - 1.5.11.3.1. Mainlane Sound and Neighborhood Walls
- 1.5.12. Bridge
 - 1.5.12.1. Frontage Road Bridge
 - 1.5.12.1.1. By Bridge Name
 - 1.5.12.2. SUP Bridge
 - 1.5.12.2.1. By Bridge Name
 - 1.5.12.3. Mainlane Bridge
 - 1.5.12.3.1. By Bridge Name
- 1.5.13. MOPAC Direct Connectors and Improvements
- 1.5.14. Tolling Infrastructure
- 1.5.15. Barriers
 - 1.5.15.1. Express Lane Median Barriers
 - 1.5.15.1.1. Permanent Concrete Barriers
 - 1.5.15.1.2. Metal Beam Guard Fence
 - 1.5.15.1.3. Crash Attenuators
 - 1.5.15.2. Frontage Road Barriers
 - 1.5.15.2.1. Permanent Concrete Barriers
 - 1.5.15.2.2. Metal Beam Guard Fence
 - 1.5.15.2.3. Crash Attenuators

- 1.5.15.3. All Other Barriers
 - 1.5.15.3.1. Permanent Concrete Barriers
 - 1.5.15.3.2. Metal Beam Guard Fence
 - 1.5.15.3.3. Crash Attenuators
- 1.5.16. Signals and Illumination
 - 1.5.16.1. Signals
 - 1.5.16.2. Mainlane Illumination
 - 1.5.16.2.1. Roadway Illumination
 - 1.5.16.2.2. High Mast Illumination
 - 1.5.16.2.3. Electrical Services
 - 1.5.16.3. Frontage Road Illumination
 - 1.5.16.3.1. Roadway Illumination
 - 1.5.16.3.2. High Mast Illumination
 - 1.5.16.3.3. Electrical Services
- 1.5.17. ITS/TCS
 - 1.5.17.1. Duct Bank System
 - 1.5.17.2. Equipment Foundation
 - 1.5.17.3. Support Structures and Equipment
- 1.5.18. Landscaping
 - 1.5.18.1. Seeding and Sodding
 - 1.5.18.2. Fertilizer and Watering
 - 1.5.18.3. Special Aesthetic Landscaping
- 1.5.19. Permanent Signing and Marking
 - 1.5.19.1. Overhead Signs
 - 1.5.19.2. Small and Large Signs
 - 1.5.19.3. Pavement Markings
- 1.5.20. Change Orders

Central Texas Regional Mobility Authority
Technical Provisions
For
183 North Mobility Project

ATTACHMENT 5-2
SOV STRUCTURE
FOR COST REPORTING

Schedule of Values Structure for Cost Reporting

1. Project
 - 1.1. Project Administration
 - 1.1.1. Mobilization
 - 1.1.1.1. Developer
 - 1.1.2. Submittals and Permitting
 - 1.1.2.1. (By Government Agency)
 - 1.1.2.1.1. (By Specific Permit/Submittal Requirement)
 - 1.1.3. Design QC and QA
 - 1.1.4. Geotech and Survey
 - 1.1.5. Community Outreach
 - 1.1.6. Bonds
 - 1.1.7. Warranties
 - 1.1.8. Insurance Premiums
 - 1.2. Right of Way Acquisition
 - 1.2.1. Acquisition by the Mobility Authority
 - 1.2.1.1. (By Parcel No.)
 - 1.2.2. Acquisition by Developer
 - 1.2.2.1. (By Parcel Number)
 - 1.3. Utility Adjustments
 - 1.3.1. Utility Coordination
 - 1.3.1.1. Administration and Planning
 - 1.3.1.1.1. Site Utility Engineering
 - 1.3.1.1.2. Conceptual Design
 - 1.3.1.2. (By Owner)
 - 1.3.1.2.1. Master Agreements
 - 1.3.1.2.2. Utility Assemblies
 - 1.3.2. Utility Relocations
 - 1.3.2.1. (By Owner)
 - 1.3.2.1.1. (By Line No.)
 - 1.4. Design
 - 1.4.1. General Activities and Field Work
 - 1.4.1.1. Design Mobilization
 - 1.4.1.2. Schematics
 - 1.4.1.3. Survey Work
 - 1.4.1.4. Geotechnical Investigations
 - 1.4.1.5. Additional Field Investigations
 - 1.4.2. Develop Specifications
 - 1.4.2.1. (By Discipline)
 - 1.4.3. Geotechnical Design
 - 1.4.3.1. General
 - 1.4.3.2. Earthwork Geotech

- 1.4.3.3. Bridge Geotech
- 1.4.3.4. Culvert Geotech
- 1.4.3.5. Wall Geotech
- 1.4.3.6. Pavement Borings
- 1.4.4. Pavement Design
 - 1.4.4.1. Data Analysis and Draft Report
 - 1.4.4.2. Final Design and Report
- 1.4.5. Drainage Design
 - 1.4.5.1. Hydrologic and Hydraulic Design
 - 1.4.5.2. Preliminary System Design
 - 1.4.5.3. Detailed Drainage Design
- 1.4.6. Roadway Design
 - 1.4.6.1. Alignments
 - 1.4.6.2. Earthwork
 - 1.4.6.3. Typical Sections
 - 1.4.6.4. Detailed Design
- 1.4.7. Bridge Design
 - 1.4.7.1. Establish Criteria and Procedures
 - 1.4.7.2. Bridge Layouts
 - 1.4.7.3. Substructure Design
 - 1.4.7.4. Superstructure Design
- 1.4.8. Retaining Wall Design
 - 1.4.8.1. Establish Criteria and Procedures
 - 1.4.8.2. Fill Wall Design
 - 1.4.8.3. Cut Wall Design
- 1.4.9. Traffic Management
 - 1.4.9.1. Traffic Control Development (By Phase)
- 1.4.10. Environmental Design
 - 1.4.10.1. Erosion Control/SWPPP/EPIC
 - 1.4.10.2. Noise Wall Design
- 1.4.11. Landscape and Aesthetic design
 - 1.4.11.1. Landscape Design
 - 1.4.11.2. Aesthetic Design
- 1.4.12. Electrical Design
 - 1.4.12.1. Illumination
 - 1.4.12.2. Traffic Signals
- 1.4.13. ITS and TCS Design
 - 1.4.13.1. Duct Bank System & Power Supply
 - 1.4.13.2. ITS/TCS Equipment and Structures
- 1.4.14. Signage and Marking Design
 - 1.4.14.1. Overhead Signs
 - 1.4.14.2. Small and Large Signs
 - 1.4.14.3. Pavement Markings

- 1.4.15. Design Packages
 - 1.4.15.1. Package Preparation
 - 1.4.15.2. QA/QC Review
 - 1.4.15.3. Submittal
 - 1.4.15.4. TxDOT/IE Reviews
 - 1.4.15.5. Comment Resolution
- 1.5. Construction
 - 1.5.1. Quality Management and Testing
 - 1.5.1.1. Quality Control
 - 1.5.2. Maintenance of Corridor & Courtesy Patrol
 - 1.5.3. Traffic Control and Temporary Work
 - 1.5.3.1. Barricades, Signs and Traffic Handling
 - 1.5.3.2. Erosion Control
 - 1.5.3.3. Detour Construction/Removal
 - 1.5.3.4. Portable Traffic Barrier
 - 1.5.3.5. Workzone Pavement Marking
 - 1.5.3.6. Temporary Bridges/Shoo-Flys
 - 1.5.3.7. Temporary Walls/Shoring
 - 1.5.3.8. Temporary Drainage
 - 1.5.4. Environmental Mitigation
 - 1.5.4.1. Noise Walls
 - 1.5.4.2. Wetland and Habitat Mitigation
 - 1.5.5. Hazardous Mitigation
 - 1.5.5.1. Site Assessments
 - 1.5.5.2. Remediation
 - 1.5.6. Removals
 - 1.5.6.1. Frontage Road Removals
 - 1.5.6.1.1. Building Removals
 - 1.5.6.1.2. ROW Preparation
 - 1.5.6.1.3. Roadway Removals
 - 1.5.6.1.4. Bridge Removals
 - 1.5.6.2. SUP Removals
 - 1.5.6.2.1. Building Removals
 - 1.5.6.2.2. ROW Preparation
 - 1.5.6.2.3. Roadway Removals
 - 1.5.6.2.4. Bridge Removals
 - 1.5.6.3. Mainlane Removals
 - 1.5.6.3.1. Building Removals
 - 1.5.6.3.2. ROW Preparation
 - 1.5.6.3.3. Roadway Removals
 - 1.5.6.3.4. Bridge Removals

- 1.5.7. Earthwork
 - 1.5.7.1. Frontage Road Earthwork
 - 1.5.7.1.1. Topsoil Stripping and Placing
 - 1.5.7.1.2. Excavation
 - 1.5.7.1.3. Embankment
 - 1.5.7.1.4. Special Geotechnical Measures
 - 1.5.7.2. SUP Earthwork
 - 1.5.7.2.1. Topsoil Stripping and Placing
 - 1.5.7.2.2. Excavation
 - 1.5.7.2.3. Embankment
 - 1.5.7.2.4. Special Geotechnical Measures
 - 1.5.7.3. Mainlane Earthwork
 - 1.5.7.3.1. Topsoil Stripping and Placing
 - 1.5.7.3.2. Excavation
 - 1.5.7.3.3. Embankment
 - 1.5.7.3.4. Special Geotechnical Measures
- 1.5.8. Subgrade Treatment and Base
 - 1.5.8.1. Frontage Road Subgrade and Base
 - 1.5.8.1.1. Lime Treatment and Other
 - 1.5.8.1.2. Flexible Base
 - 1.5.8.2. SUP Subgrade and Base
 - 1.5.8.2.1. Lime Treatment and Other
 - 1.5.8.2.2. Flexible Base
 - 1.5.8.3. Mainlane Subgrade and Base
 - 1.5.8.3.1. Lime Treatment and Other
 - 1.5.8.3.2. Flexible Base
- 1.5.9. Drainage
 - 1.5.9.1. Frontage Road Drainage
 - 1.5.9.1.1. Culverts
 - 1.5.9.1.2. Storm Sewer
 - 1.5.9.1.3. Riprap
 - 1.5.9.2. SUP Road Drainage
 - 1.5.9.2.1. Culverts
 - 1.5.9.2.2. Storm Sewer
 - 1.5.9.2.3. Riprap
 - 1.5.9.3. Mainlane Drainage
 - 1.5.9.3.1. Culverts
 - 1.5.9.3.2. Storm Sewer
 - 1.5.9.3.3. Riprap
- 1.5.10. Pavement
 - 1.5.10.1. Frontage Road Pavement
 - 1.5.10.1.1. Asphalt Pavement
 - 1.5.10.1.2. Concrete Pavement
 - 1.5.10.1.3. Curb and Gutter

- 1.5.10.1.4. Driveways
- 1.5.10.1.5. Sidewalk and Median Paving
- 1.5.10.2. SUP Paving
 - 1.5.10.2.1. Asphalt Pavement
 - 1.5.10.2.2. Concrete Pavement
 - 1.5.10.2.3. Curb and Gutter
 - 1.5.10.2.4. Driveways
 - 1.5.10.2.5. Sidewalk and Median Paving
- 1.5.10.3. Mainlane Pavement
 - 1.5.10.3.1. Asphalt Pavement
 - 1.5.10.3.2. Concrete Pavement
 - 1.5.10.3.3. Curb and Gutter
 - 1.5.10.3.4. Driveways
 - 1.5.10.3.5. Sidewalk and Median Paving
- 1.5.11. Retaining Walls
 - 1.5.11.1. Frontage Road Retaining Walls
 - 1.5.11.1.1. Frontage Sound and Neighborhood Walls
 - 1.5.11.2. SUP Retaining Walls
 - 1.5.11.2.1. SUP Sound and Neighborhood Walls
 - 1.5.11.3. Mainlane Retaining Walls
 - 1.5.11.3.1. Mainlane Sound and Neighborhood Walls
- 1.5.12. Bridge
 - 1.5.12.1. Frontage Road Bridge
 - 1.5.12.1.1. By Bridge Name
 - 1.5.12.2. SUP Bridge
 - 1.5.12.2.1. By Bridge Name
 - 1.5.12.3. Mainlane Bridge
 - 1.5.12.3.1. By Bridge Name
- 1.5.13. MOPAC Direct Connectors and Improvements
- 1.5.14. Tolling Infrastructure
- 1.5.15. Barriers
 - 1.5.15.1. Express Lane Median Barriers
 - 1.5.15.1.1. Permanent Concrete Barriers
 - 1.5.15.1.2. Metal Beam Guard Fence
 - 1.5.15.1.3. Crash Attenuators
 - 1.5.15.2. Frontage Road Barriers
 - 1.5.15.2.1. Permanent Concrete Barriers
 - 1.5.15.2.2. Metal Beam Guard Fence
 - 1.5.15.2.3. Crash Attenuators
 - 1.5.15.3. All Other Barriers
 - 1.5.15.3.1. Permanent Concrete Barriers
 - 1.5.15.3.2. Metal Beam Guard Fence
 - 1.5.15.3.3. Crash Attenuators

- 1.5.16. Signals and Illumination
 - 1.5.16.1. Signals
 - 1.5.16.2. Mainlane Illumination
 - 1.5.16.2.1. Roadway Illumination
 - 1.5.16.2.2. High Mast Illumination
 - 1.5.16.2.3. Electrical Services
 - 1.5.16.3. Frontage Road Illumination
 - 1.5.16.3.1. Roadway Illumination
 - 1.5.16.3.2. High Mast Illumination
 - 1.5.16.3.3. Electrical Services
- 1.5.17. ITS/TCS
 - 1.5.17.1. Duct Bank System
 - 1.5.17.2. Equipment Foundation
 - 1.5.17.3. Support Structures and Equipment
- 1.5.18. Landscaping
 - 1.5.18.1. Seeding and Sodding
 - 1.5.18.2. Fertilizer and Watering
 - 1.5.18.3. Special Aesthetic Landscaping
- 1.5.19. Permanent Signing and Marking
 - 1.5.19.1. Overhead Signs
 - 1.5.19.2. Small and Large Signs
 - 1.5.19.3. Pavement Markings
- 1.5.20. Change Orders

Central Texas Regional Mobility Authority
Technical Provisions
For
183 North Mobility Project

ATTACHMENT 6-1
UPRR SCOPE OF WORK

DISCLAIMER: The use of this standard is governed by the "Texas Engineering Practice Act". No warranty of any kind is made by TxDOT for any purpose whatsoever. TxDOT assumes no responsibility for the conversion of this standard to other formats or for incorrect results or damages resulting from its use.

DATE: FILE:

I. WORK AT CROSSING LOCATIONS (AT GRADE, HIGHWAY OVERPASS, HIGHWAY UNDERPASS, PEDESTRIAN, OR CLOSED/ABANDONED)

DOT #	Highway Type & Number	Latitude & Longitude	CROSSING TYPE	ROAD WORK	Primary Operating Railroad	INSURANCE	FLAGGING	RIGHT OF ENTRY	NOTIFICATION LETTER
975136F	US 183	30.379174, -97.7359600	HIGHWAY OVERPASS	PAVEMENT MARKINGS ON BRIDGE	Union Pacific Railroad Company	YES	NO	NO	YES
435971R	US 183	30.3784930, -97.7362450	HIGHWAY OVERPASS	PAVEMENT MARKINGS ON BRIDGE	Union Pacific Railroad Company	YES	NO	NO	YES
975137M	US 183	30.3779700, -97.7364660	HIGHWAY OVERPASS	PAVEMENT MARKINGS ON BRIDGE	Union Pacific Railroad Company	YES	NO	NO	YES
DOT #	Highway Type & Number	RR Subdivision or District	City	Street/Road Name & Block Number	RR Milepost	Total Day Thru Trains	Total Switching Trains		
975136F	US 183	AUSTIN SUB	AUSTIN	US 183 EXIT RAMP	171.183	11	0		
435971R	US 183	AUSTIN SUB	AUSTIN	US 183	171.23	11	0		
975137M	US 183	AUSTIN SUB	AUSTIN	US 183 EXIT RAMP	171.268	11	0		

II. OTHER PROJECT WORK WITHIN RAILROAD RIGHTS-OF-WAY (ROW)

None

III. FLAGGING

of Days of Railroad Flagging Expected: 0
 On this project, night or weekend flagging is:
 Expected
 Not Expected

Flagging services will be provided by:
 Railroad Company: TxDOT will pay flagging invoices
 Outside Party: Contractor will pay flagging invoices, to be reimbursed by TxDOT

Contractor must incorporate flaggers into anticipated construction schedule. The railroad requires a 30 day notice if their flaggers are to be utilized. If contractor falls behind schedule due to their own negligence and is not ready for scheduled flaggers, any flagging charges will be paid by Contractor.

Contact Information for Flagging:

RAILPROS FIELD SERVICES
(877) 315-0513 X116
Upflag@railprosfs.COM

IV. CONSTRUCTION WORK TO BE PERFORMED BY THE RAILROAD

On this project, construction work to be performed by a railroad company is:
 Required
 Not Required

Coordinate with TxDOT for any work to be performed by the railroad company. TxDOT must issue a work order for any work done by the railroad company prior to the work being performed.

V. RAILROAD INSURANCE REQUIREMENTS

Contractor shall provide the proper insurance as shown in the table below, for work on the ROW or as noted.

Required for work within 50ft of Railroad ROW or over Railroad ROW

Insurance policies must be issued for and on behalf of the Railroad. Where more than one Railroad Company is operating on the same right of way or where several railroad companies are involved and operate on their own separate rights of way, provide separate insurance policies in the name of each Railroad Company.

No direct compensation will be made to the contractor for providing the insurance coverages shown below or any deductibles. These costs are incidental to the various bid items.

Type of Insurance	Amount of Coverage (Minimum)
Workers Compensation	\$500,000 / \$500,000 / \$500,000
Commercial General Liability	\$2,000,000 / \$4,000,000
Business Automobile	\$2,000,000 combined single limit
Railroad Protective Liability	\$2,000,000 / \$6,000,000

VI. CONTRACTOR'S RIGHT-OF-ENTRY (ROE) AGREEMENT

On this project, an ROE agreement is:
 Not Required, Notification Letter to UPRR
 Required: TxDOT to assist in obtaining (see Item 5, Article 8.3)

With the following railroad companies: _____

Required: Contractor to obtain (see Item 5, Article 8.4)

With the following railroad companies: _____

To view previously approved ROE agreement templates agreed upon between the State and railroad company, see:

<http://www.txdot.gov/inside-txdot/division/traffic/samples.html>

Approved ROE agreement templates are not to be modified by the Contractor.

Contractor shall not operate within railroad rights of way without an executed Construction & Maintenance agreement between the state and the railroad and an executed ROE agreement between the contractor and the railroad if required on project.

VII. RAILROAD COORDINATION MEETING

On this project, a Railroad Coordination Meeting is:

Not Required
 Required

See Item 5, Article 8.1 for more details.

VIII. SUBCONTRACTORS

Contractor shall not subcontract work without written consent of TxDOT. Subcontractors are required to maintain the same insurance coverage as required of the Contractor.

IX. EMERGENCY NOTIFICATION

In Case of Railroad Emergency
Call UNION PACIFIC RAILROAD EMERGENCY LINE
AT 888-877-7267

 Texas Department of Transportation				Traffic Operations Division	
<h2 style="margin: 0;">RAILROAD SCOPE OF WORK</h2> <h3 style="margin: 0;">PROJECT SPECIFIC DETAILS</h3>					
FILE:	DN: TxDOT	CK:	DW:	CK:	
© TxDOT	CONT	SECT	JOB	HIGHWAY	
APRIL 2019	6340	37	001	VARIOUS	
REVISIONS	DIST	COUNTY		SHEET NO.	
	14	TRAVIS			

183 North Mobility Project

AESTHETICS DESIGN GUIDE
EXECUTION COPY



CENTRAL TEXAS REGIONAL
MOBILITY AUTHORITY

Table of Contents

Section 1.0 Overall Aesthetic Summary

Introduction

S-1 – S-3 Aesthetics Plan Summary

M-1 Aesthetics Plan Matrix

M-2 Color Palette

Section 2.0 Aesthetic Details

Section 2.0 Index

2.1.1 – 2.1.2 Cross-Street Intersection Bridge Treatments

2.1.3 - 2.1.5 Loop 1 to US 183 Direct Connector Bridges

2.2.0 Major Guide Sign/ITS Support Structures

2.3.0 Tollway Gantry Support Structures

2.4.0 - 2.4.1 Column Sizes and Reveal Placement Details

2.4.2 Decorative Cap Details

2.4.3 Cap Ear Wall Details

2.4.4 - 2.4.7 Standard Bent Cap Details

2.4.8 Mast Lighting Tower Base Details

2.4.9 Aesthetic Area 2/Select DC Area 3 - Bridge Painting Details

2.5.0 - 2.5.1 Retaining Wall Texture Pattern and Details

2.5.2 Retaining Wall Slip Joint Cover Details

2.5.3 Abutment Wall and Coping Details

2.6.0 Vehicle Safety Barriers

2.7.0 Storm Water Basin Fencing

2.8.0 - 2.8.1 Pond Springs Rd./McNeil Dr. Interchange Plaza Pavement

2.8.2 SUP Special Pavement

2.9.0 SUP Overhead Art

2.10.0 - 2.10.17 Corridor Concept Landscape Plan

2.11.0 - 2.11.6 Landscape Details

2.11.7 Landscape Plant Palette

Introduction

This Aesthetics Master Plan summarizes the aesthetic treatments required for the US 183 corridor and is a refinement of the preliminary design concepts approved by the CTRMA during the public outreach and internal design process conducted previously. The refinements herein reflect changes in the project corridor aesthetic treatments as the result of advancement of the engineering schematic design, incorporation of refined CTRMA input addressing constructability realities, and the need to reduce long-term operations and maintenance costs associated with the final aesthetic treatments.

The Aesthetics Master Plan is organized in the following two sections:

Section 1. Overall Aesthetic Summary - This section includes a summary overview of the project aesthetics as well as summary matrices and color palette of the aesthetic improvements to be incorporated in the project by location and project element.

Section 2. Aesthetic Details – This section contains the aesthetic design details for all the required improvements organized by element.

183 North Mobility Project

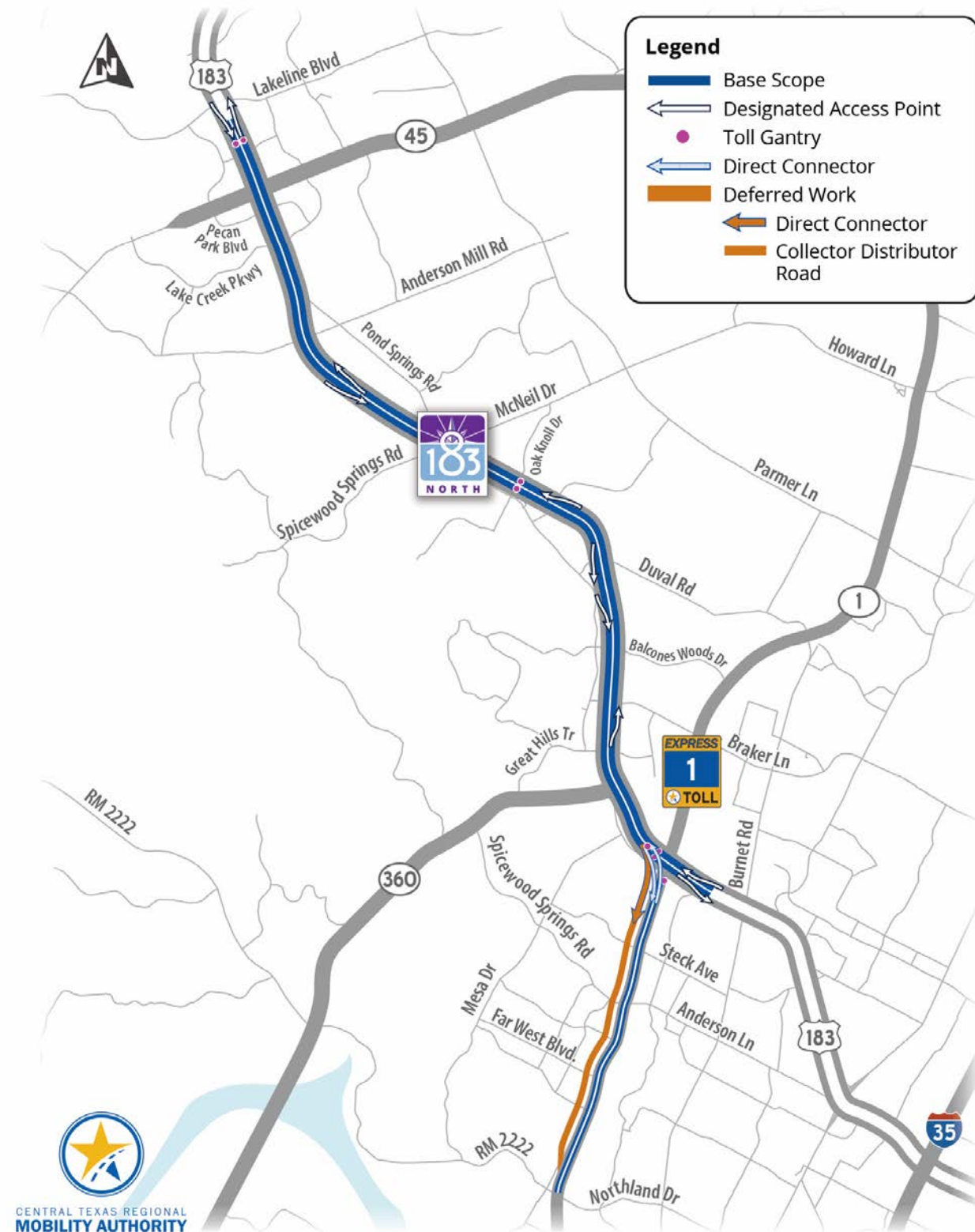

Project Limits

Aesthetics Plan Summary

Overall Aesthetic Summary

The aesthetic treatments proposed for the 183 North Mobility Project corridor have been organized into three primary treatment areas. These include :

- Area 1. Replicate Existing Aesthetic Treatments
- Area 2. 183 North Mobility Project Aesthetics
- Area 3. Loop 1 /US 183 Interchange Aesthetics

The following narrative describes the rationale and outlines the treatments which are to be applied to all areas of the corridor.

Area 1. Replicate Existing Aesthetic Treatments

The area of the replication of existing aesthetic treatments occurs from the north terminus of the project to the north abutment of the Pecan Park Blvd. interchange. All improvements within this zone will replicate the aesthetic forms textures and color palette used on the existing structures. The new facilities shall be designed to fit within and to match the existing design aesthetic based upon the as-built drawings from the original interchange construction. This generally includes the aesthetic treatments to the following elements:

- Replace in kind all non-vehicular specialty surface paving, patterns and arrangements including both hard surfaces cast- in-place concrete sidewalks, concrete pavers and aggregate ground covers within the intersection which are disturbed during construction. Efforts are to be made soften the color of new poured-in-place concrete sidewalk pavement to closely match the patina on the surrounding existing concrete sidewalk to remain.
- Treatments to bridge abutment faces and retaining walls including MSE panel texture, faux pilaster forms all aesthetic elements attached to abutment and retaining wall proximate to the interchange shall match existing.
- Unique bridge substructure shapes shall match form, size, surface texture patterns, reveals, cap soffit and color to the existing
- Girder types, depths and; exterior barrier railing face profile shall match existing
- Provide under bridge lighting to match existing color profile
- Shape texture and configuration of major guide sign support towers (if any) to match existing
- Paint palette for all elements above to be replicated to match existing.
- Clean all at grade and second level structures associated with the 183 corridor to include existing retaining walls, copings, site walls, pedestrian pavement, slope paving, bridge barrier railings, exterior bridge deck, bent caps (all surfaces) and entire bent columns to remain.

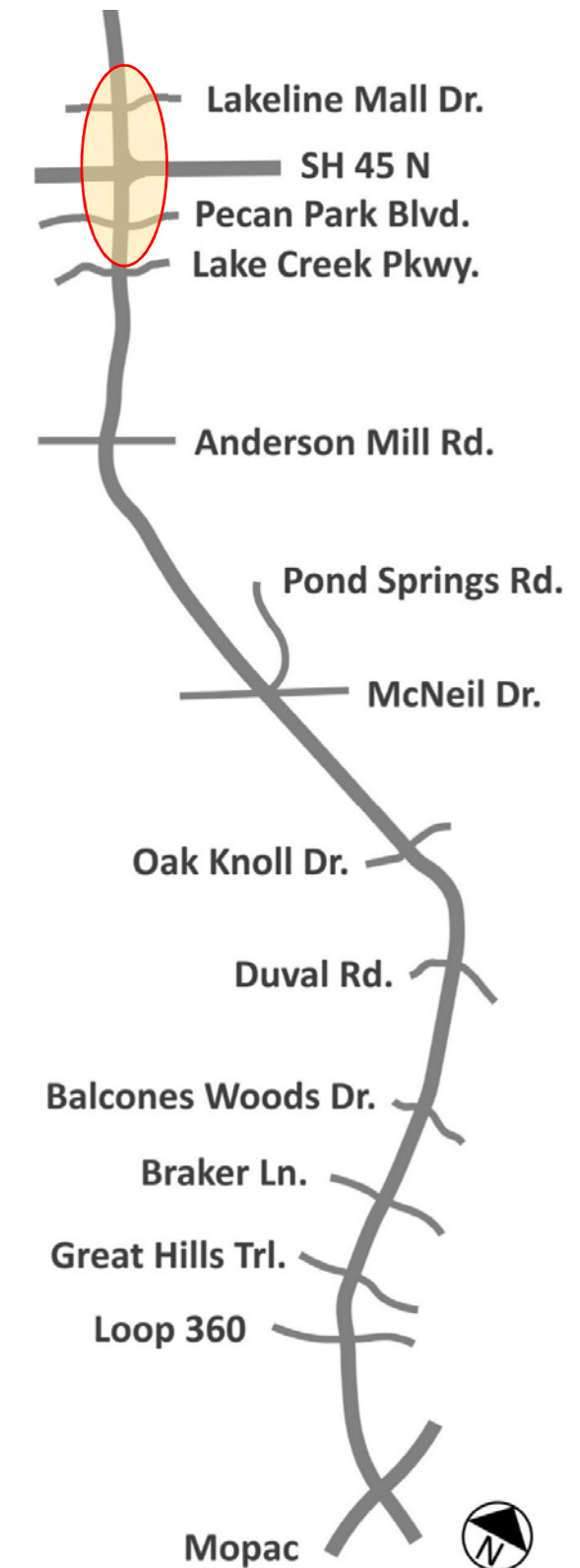

Area 1. Replication Zone Limits

Aesthetics Plan Summary

Area 2. 183 North Mobility Project Aesthetic Treatments

The elements within this area represent the application of the 183 North Mobility Project Design Guidelines. Interchanges which receive these treatments included:

- Lake Creek Parkway
- Anderson Mill Rd.
- Pond Springs Rd. / Spicewood Springs Rd./ McNeil Dr.
- Oak Knoll Dr.
- Duval Rd.
- Balcones Woods Dr.
- West Braker Ln.
- Great Hills Trail
- Loop 360
- Portions of the Loop 1 /US 183 Interchange

Elements to include treatment include:

- Construct decorative column at cross-street interchanges per project aesthetics.
- At specific locations provide the Cap Ear Wall treatment in lieu of decorative column – See Sheet 2.8.0 for locations
- Paint all new elements of the construction as indicated in the Design Guide
- Clean all surfaces of the existing bridge caps, girders and columns
- Paint sides, ends, and undersides of all caps and entire columns of existing bents to remain.
- Paint entire exterior face and lower flange of fascia girders. Paint lower flange of all interior girders.
- Clean and paint all slope paving under existing and new bridges
- Construct new retaining walls to meet the 183 North Mobility Project aesthetic standards
- In locations where new retaining walls meet or attach to existing retaining walls, install slip joint cover to provide transition See Sheet 2.5.2
- Clean the existing retaining walls, coping and accessories to remain, per the requirements as stipulated in the Technical Provisions
- Paint to 183 North Mobility Project Standards, all exposed surfaces of existing vehicle barriers and retaining wall coping to remain.
- Construct new major guide sign, toll gantry and ITS messaging supports to the 183 North Mobility Project standards
- Construct mast lighting pole foundations to project standards
- Construct landscape planters and associate planting at cross-street interchanges per project concept landscape plan
- Renovate non-vehicular pavements to remain within cross-street interchanges to project standards.
- Provide Specialty pavement for the SUP Undercrossing at the Pond Springs Rd./McNeil Dr. interchange per the project standards
- Construct the specialty overhead art and lighting installation along the SUP Undercrossing at Pond Springs Rd.
- Provide plaza paving within the Pond Springs Rd./McNeil Dr. interchange per the concept plan

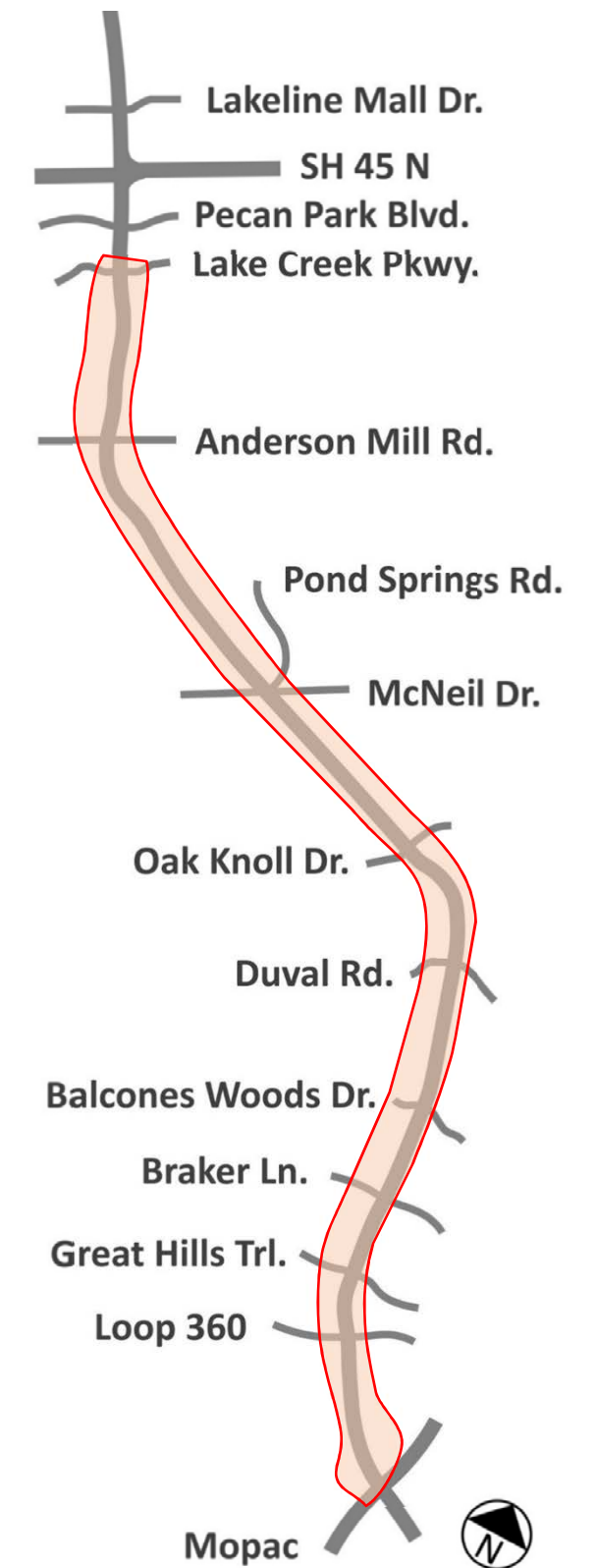

Area 2. 183 North Mobility Project Aesthetic Treatment Limits

Aesthetics Plan Summary

Area 3. Loop 1 /US 183 Interchange

Loop 1 /US 183 Interchange

The Loop 1/US 183 Interchange provides an opportunity to create the transition from the existing functional/structural forms of the system to system interchange to that of the 183 North Mobility Project design aesthetic. Since all existing direct connector (DC) Bridges will be retained, an aesthetic transition from the Loop 1 corridor to that of the US 183 corridor must be developed. In that regard the following interventions will be undertaken to make the transition.

- The new north bound Loop 1 to 183 North Mobility Project (DC) will follow the 183 North Mobility Project Aesthetics guide of form color and texture for all bridge structures.
- The Loop 1 to 183 North Mobility Project (DC) abutment at the Loop 1 connection and associated retaining walls (launch point) of the will use the Loop 1 Aesthetic texture and color palette. See below
- The noise wall parallel to the Direct Connector launch point will use the Loop 1 noise wall Aesthetic treatment and color palette. See below
- Clean and paint the abutments and wing walls, of the US 183 Main lane overpass bridges
- Clean and paint portions of the Direct Connector Bridges as indicated in Matrix Area 3.

The following Direct Connectors structures will transition from the existing color palette to the 183 North Mobility Project color palette as follows:

- The existing Loop 1 Existing NB Loop1 to NB US 183 DC, Ramp S-W, Bent 14, DC STA 259+84.74
- The existing US 183 SB US 183 to NB Loop 1 DC (under new DC), Ramp W-N, Bent 2, DC STA 261+43.65
- The existing SB US 183 to SB Loop1 DC at split Ramp W-S, Bent 8, DC STA 259+34.94
- The north abutment (landing point) of the / Loop 1 to US 183 N (DC) abutment will follow the US 183 N aesthetic
- Provide protection of existing vegetation to remain as indicate on plans



Loop 1 Aesthetic – Vertical Abutment at DC to US 183 N

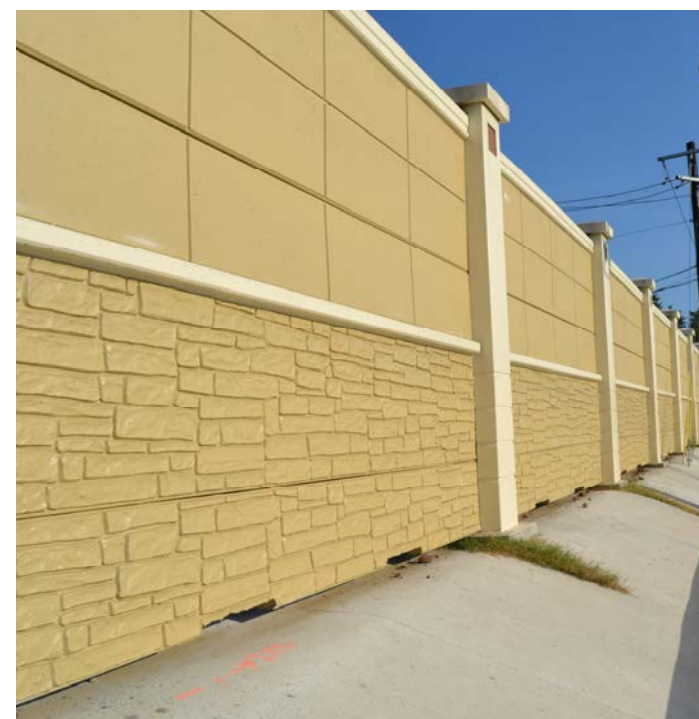

Loop 1 Aesthetic – Standard Noise Wall

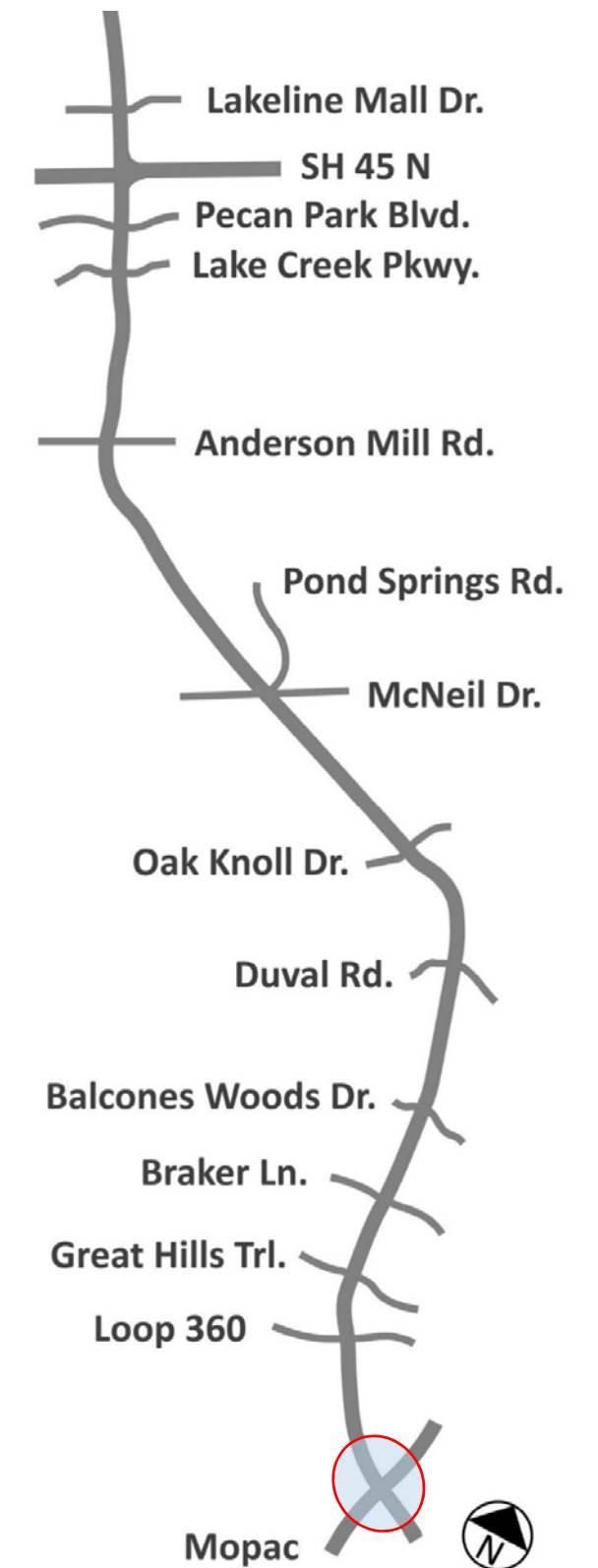

Area 3. Loop 1 /US 183 Interchange

Note: The following matrix summarizes the intended aesthetic treatment by area and intersection/interchange

Aesthetics Plan Matrix

Treatment Area	Location	Cross Street Intersection Decorative Columns	Cap Ear Wall	183 North Mobility Project Paint Palette	Landscape Planters at abutments	Specialty Non-Vehicular Pavements	183 North Mobility Project Retaining Wall Aesthetic	Existing Retaining Walls to Remain	Paint Slope Pavement	Match Existing Aesthetic Treatments	183 North Mobility Project Aesthetics Major Sign, ITS and Toll Gantry	Comments
1	Lakeline Mall Dr.	NA	NA	NA	NA	NA	NA	X	NA	X	NA	All improvements to match existing aesthetic treatments.
1	US 183 at SH45	NA	NA	NA	X							All improvements to match existing aesthetic treatments.
1	Pecan Park Blvd.	NA	NA	NA	X	NA	NA	X	NA	X	X	Supplement Plantings along walls in linear fashion a space allows
2	Lake Creek Pkwy.	X	NA	X	X	NA	NA	X	X	NA	X	Landscape Planters on south side of interchange only, remove paver rip-rap adjacent to wing walls to facilitate planter wall installation. Paint transition of exterior girders, deck and barrier faces to occur at current location north of intersection.
2	Anderson Mill Dr.	X	NA	X	X	NA	X	X	X	NA	X	Provide transition between existing retaining walls to remain and 183 North Mobility Project Aesthetics
2	Pond Springs Rd.	X	X	X	X	X	X	NA	X	NA	X	SUP undercrossing to receive overhead lighted art element. SUP Special and Plaza Pavements where indicated
2	McNeil Dr.	X	X	X	X	X	X	NA	X	NA	X	Clean /Repair Existing Pedestrian Pavement only
2	Oak Knoll Dr.	X	NA	X	NA	NA	X	NA	X	NA	X	Clean /Repair Existing Pedestrian Pavement only
2	Duval Rd.	X	NA	X	X	NA	X	NA	X	NA	X	Clean /Repair Existing Pedestrian Pavement only
2	Balcones Woods Dr.	X	NA	X	NA	NA	X	NA	X	NA	X	Clean /Repair Existing Pedestrian Pavement only
2	Braker Ln.	X	NA	X	X	NA	X	NA	X	NA	X	Clean /Repair Existing Pedestrian Pavement only
2	Great Hills Trail	X	NA	X	X	NA	X	NA	X	NA	X	Clean /Repair Existing Pedestrian Pavement only
3	Loop 360	X	NA	X	NA	NA	NA	NA	NA	NA	X	Provide surface mounted 12" Tall x 1.5. deep Anodized Aluminum Metal Letters to exterior face of existing bridge rail both north and south bound reading NORTH CAPITAL OF TEXAS HIGHWAY Install landscape plantings on slopes proximate to Loop 360 Interchange as needed to fulfill project requirements Clean and paint all existing substructures, girders, abutments, wingwalls, exposed faces and underside of bridge deck all exposed surfaces of concrete bridge rails and columns
3	Loop 1 Interchange North (Landing Point)	NA	NA	X	NA	NA	X	NA	NA	NA	X	Use 183 North Mobility Project Vertical Abutment Treatment
3	Loop 1 Interchange Paint Palette Transition	NA	NA	X	NA	NA	NA	NA	NA	NA	X	Cleaning of existing structures, complete walls, copings, corners, vehicle barriers, exterior bridge deck overhangs, all girders and columns/bents and application of new painting palette begins at the following locations and includes the complete painting of the bridge and wall structures and identified bents: • Existing NB Loop1 to NB US 183 N DC, Ramp S-W, Bent 14, DC STA 259+84.74 • Existing US 183 SB US 183 to NB Loop 1 DC (under new DC), Ramp W-N, Bent 2, DC STA 261+43.65 • Existing SB US 183 to SB Loop1 DC at split Ramp W-S, Bent 8, DC STA 259+34.94
3	Loop 1 Interchange South (Launch Point)	NA	NA	NA	NA	NA	NA	NA	NA	NA	X	Use Loop 1 Vertical Abutment Treatment
3	US 183 /Loop 1 Overpass	NA	NA	NA	NA	NA	NA	NA	NA	NA	NA	Clean and paint existing abutments US 183 Main and Toll Lane Structures with North Mobility Project Color Palette

Note: The following matrix identifies the application of and color selection for all surfaces to be coated as a part of the 183 North Mobility Project Aesthetics Requirements. In Aesthetic Treatment Areas 1 and 3, color palette to match existing unless otherwise indicated.

Color Palette

Element	Balanced Biege SW 7037	Tony Taupe SW 7038	Warm Stone SW 7032	Rugged Brown SW 6062	Natural Concrete *	Concrete Solomon - Asphalt 908 **	Concrete Solomon-Sandalwood 242 ***
Columns: Bridge, ITS, Toll Gantry, Major Sign	X						
Bent Caps, Straddle Bent (Entire)	X						
Cross Street Interchange Decorative Column (Entire)	X						
Decorative Column Caps: Toll Gantry, Major Sign			X				
Cap Ear Wall	X						
Mast Lighting Tower Base	X						
Vehicle Barrier Exterior Faces and Top		X					
Bridge and Wall Mounted Barrier- Inset Panel			X				
Fascia Girder and Underside and bottom flange of Cross Street interior girders (Area 2) -Fascia girders on select portions existing DC bridges (Area 3)			X				
Slope Pavement	X						
Retaining Wall Panels and Corners	X						
Retaining Wall Coping and Slip Joint Cover		X					
Pond Springs/McNeil Rd. Plaza Pavement- Field						X	
Pond Springs/McNeil Rd. Plaza Pavement - Accent							X
SUP Special Pavement - Field					X		
SUP Special Pavement -Accent 1						X	
SUP Special Pavement -Accent 2							X
SUP Overhead Art Metal				X			
Fencing -Decorative Metal Fence and Railing, Chain Link			X				

All concrete flatwork to have tooled edges and medium broom finished surface.
 * Contractor to provide minimum 10'x5' mockup panel for color and texture approval
 ** Contractor to provide minimum 10'x5' mockup panel for color and texture approval
 *** Contractor to provide minimum 10'x2' mockup panel for color and texture approval

Section 2.0 Aesthetic Details – This section contains the aesthetic design details for all the required improvements organized by element as follows:

- 2.1.1 – 2.1.2 Cross-Street Intersection Bridge Treatments
- 2.1.3 - 2.1.5 Loop 1 to US 183 Direct Connector Bridges
- 2.2.0 Major Guide Sign/ITS Support Structures
- 2.3.0 Tollway Gantry Support Structures
- 2.4.0 - 2.4.1 Column Sizes and Reveal Placement Details
- 2.4.2 Decorative Cap Details
- 2.4.3 Cap Ear Wall Details
- 2.4.4 - 2.4.7 Standard Bent Cap Details
- 2.4.8 Mast Lighting Tower Base Details
- 2.4.9 Aesthetic Area 2/Select DC Area 3 - Bridge Painting Details
- 2.5.0 - 2.5.1 Retaining Wall Texture Pattern and Details
- 2.5.2 Retaining Wall Slip Joint Cover Details
- 2.5.3 Abutment Wall and Coping Details
- 2.6.0 Vehicle Safety Barriers
- 2.7.0 Storm Water Basin Fencing
- 2.8.0 - 2.8.1 Pond Springs Rd./McNeil Dr. Interchange Plaza Pavement
- 2.8.2 SUP Special Pavement
- 2.9.0 SUP Overhead Art
- 2.10.0 - 2.10.17 Corridor Concept Landscape Plan
- 2.11.0 - 2.11.6 Landscape Details
- 2.11.7 Landscape Plant Palette

Section 2.0 Index



Exterior Decorative Column inline and outboard of existing bent line where no outside widening of Structure. Existing interior cylindrical columns remain



Exterior structural Decorative Column inline with bent where outside widening of structure. Existing interior cylindrical columns remain Decorative column connected to new cap

Cross Street Intersection Bridge Treatments

Notes:

1. Clean existing columns and cap (including top) and paint all exposed surfaces below cap top.
2. All bent lines at cross street intersections listed below to have new decorative column
3. Wherever possible the decorative column is to be structural and tied to new cap.
4. In locations where no bridge widening is required the decorative column may be free standing
5. In locations where a new decorative column will be in conflict with roadway geometry, a Cap Ear Wall shall be provided. See 2.1.2 and Cap Ear Wall details
6. Decorative column size shall be uniform through out the project except under Cap Ear Wall
7. Decorative column at Cap Ear Wall shall be no wider than the new cap
8. Interior widenings shall match existing cap shape, and cylindrical columns size similar adjacent existing structures
9. **Aesthetic lighting** is to be included on face of all Decorative Columns- lighting to be a single surface mounted fixture to provide wash of light on face of column highlighting the decorative reveals of the column. Circuitry shall be incorporated within the column as no external conduits or mounting boxes will be permitted.

Locations to receive Decorative Column

- Lake Creek Parkway
- Anderson Mill Rd.
- Spicewood Springs Rd./McNeil Dr. /Pond Springs Rd.*
- Oak Knoll Dr.
- Balcones Woods Dr.
- W. Braker Ln.
- Great Hills Trail
- Loop 360- North Capital of Texas Highway

* Two bent locations at this intersection will require the use of the Cap Ear Wall and interior decorative column only

Cross Street Intersection Bridge Treatments Cont.



Decorative Column at Bridge with outside widening typ. Interior column cylindrical - exterior column decorative and structural connected to new cap - Skewed bent location

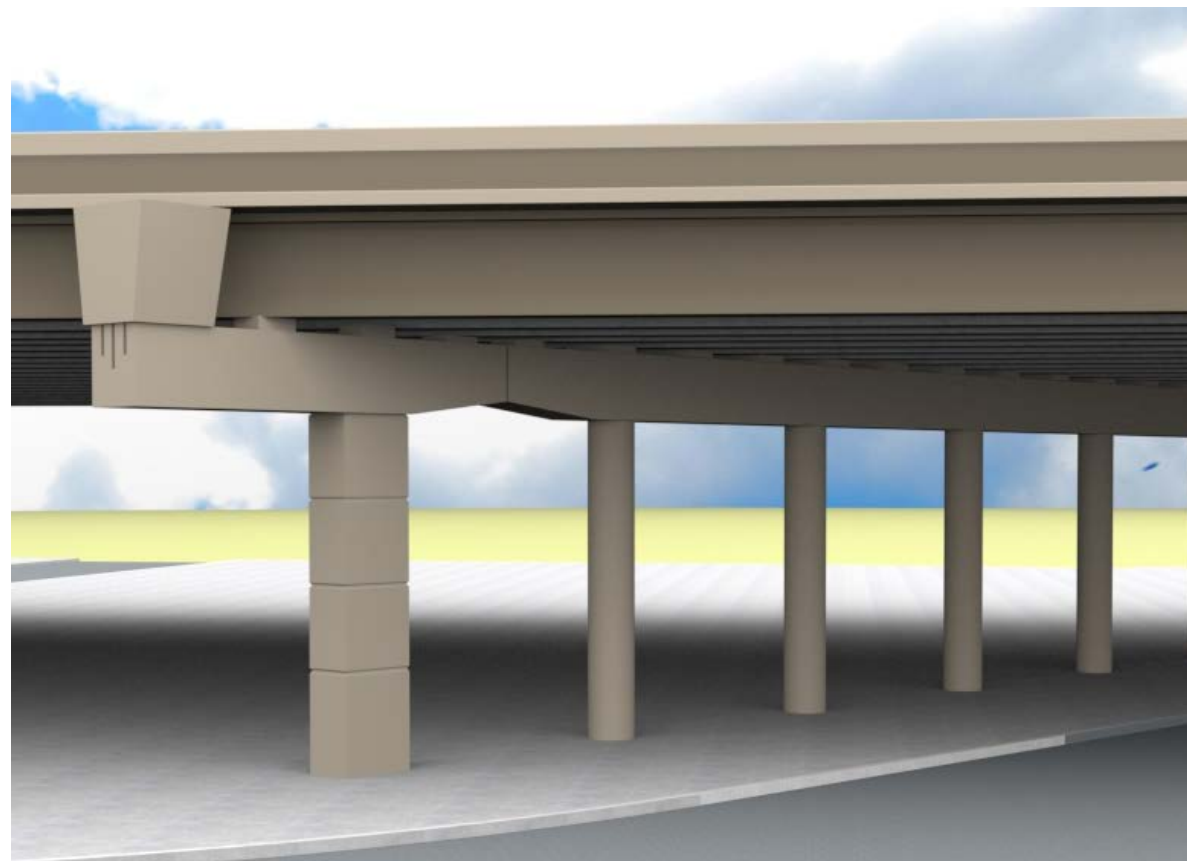

Widening where decorative column is not possible provide extended Cap, Cap Ear Wall and decorative column - Skewed bent location

Loop 1 / US 183 Direct Connector Bridges**Notes:**

1. Mixing of Hammer Head bent caps and inverted "T" bent caps will be allowed to facilitate constructability within CD and DC structures only.
2. Provide a minimum of three similar cap types in succession on a structure where mixture of bent cap types is to occur.
3. Hammer Head bent caps under soffit and faces details shall be in conformance with the aesthetic design herein.
4. The use of cast-in-place and or pre-cast concrete bent caps is permissible.

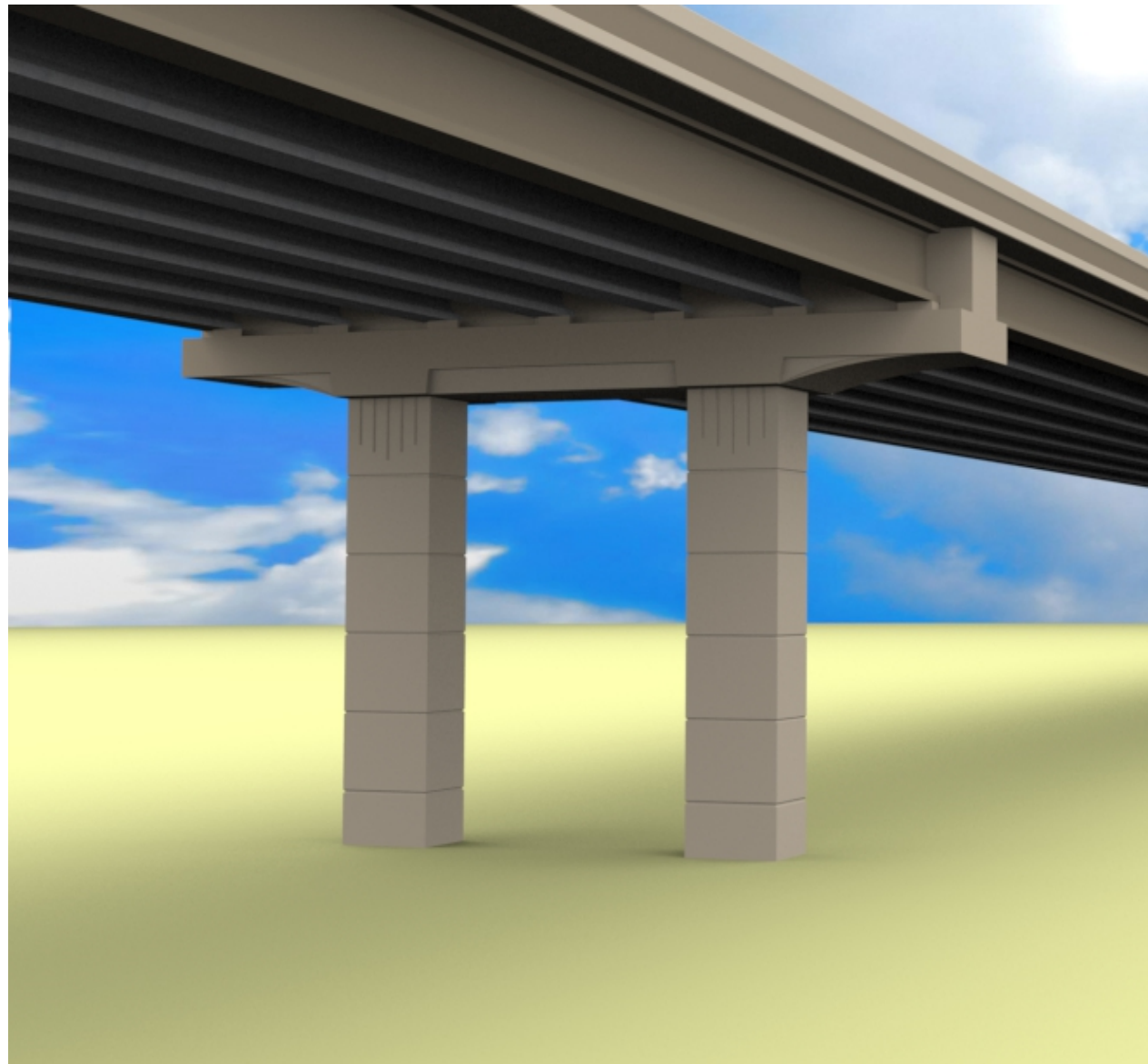

Inverted "T" - Twin Column Bent - Double Structure

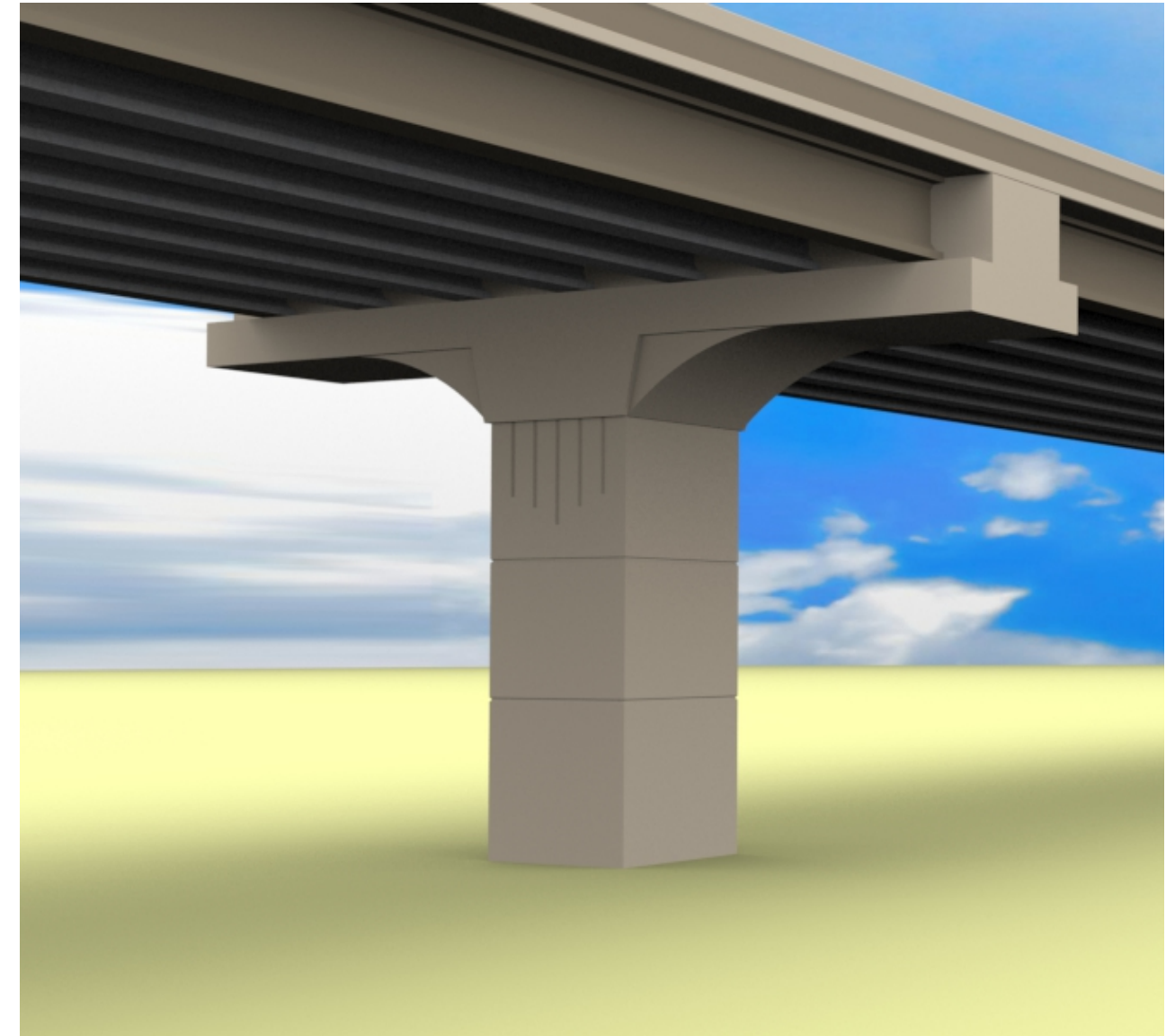

Inverted "T"- Hammer Head Bent - Double Structure

Loop 1 / US 183 Direct Connector Bridges



Inverted "T" - Cantilever Hammer Head – Single Structure



Inverted "T" - Symmetrical Hammer Head – Single Structure

Loop 1 / US 183 Direct Connector Bridges

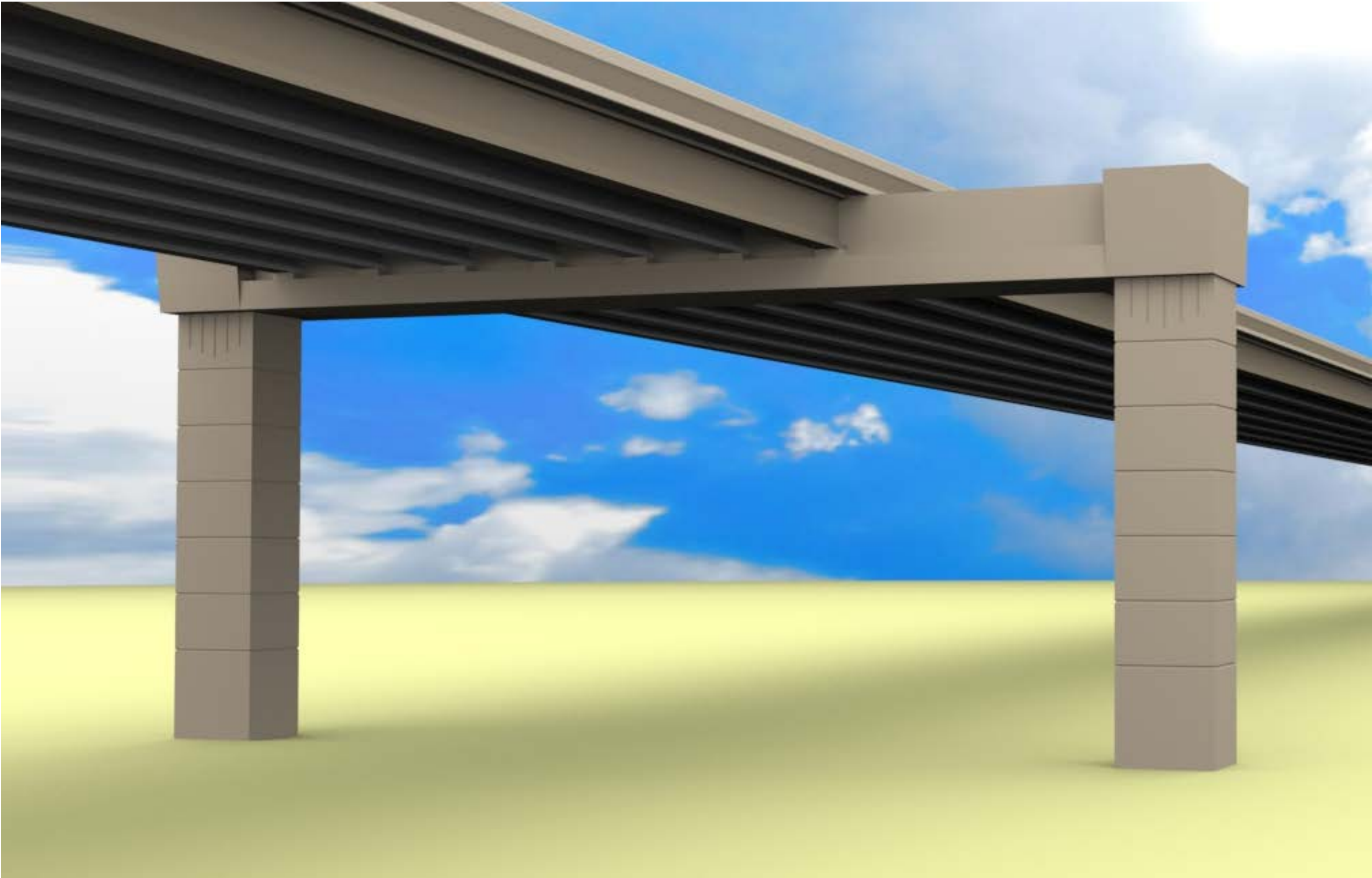

Straddle Bent- Loop 1 to 183 North Mobility Project DC

Major Guide Sign/ITS Support Structures



Major Guide Sign / ITS Support Structure

Notes

1. ITS message boards shall be mounted in place of standard guide signs.
2. Tower and decorative cap to be identical for both applications
3. See details for cap dimensions
4. See RID for structural details

Toll Gantry Support Structures



Bridge Style Toll Gantry

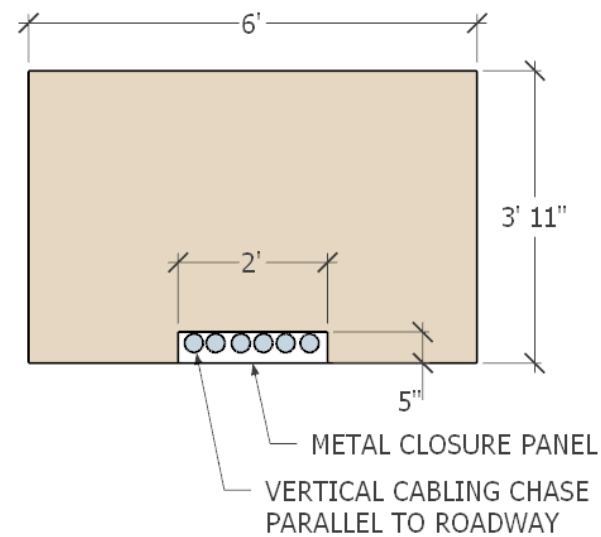

Section Through Outer Toll Gantry Column

Notes

1. Paired Gantry configuration may be required to support all necessary tolling equipment. Single gantry configuration illustrated for convenience only.
2. Center support tower to be 2' wide at base protected by tapered/widened vehicle barrier as required.

Column Sizes and Reveal Placement Details

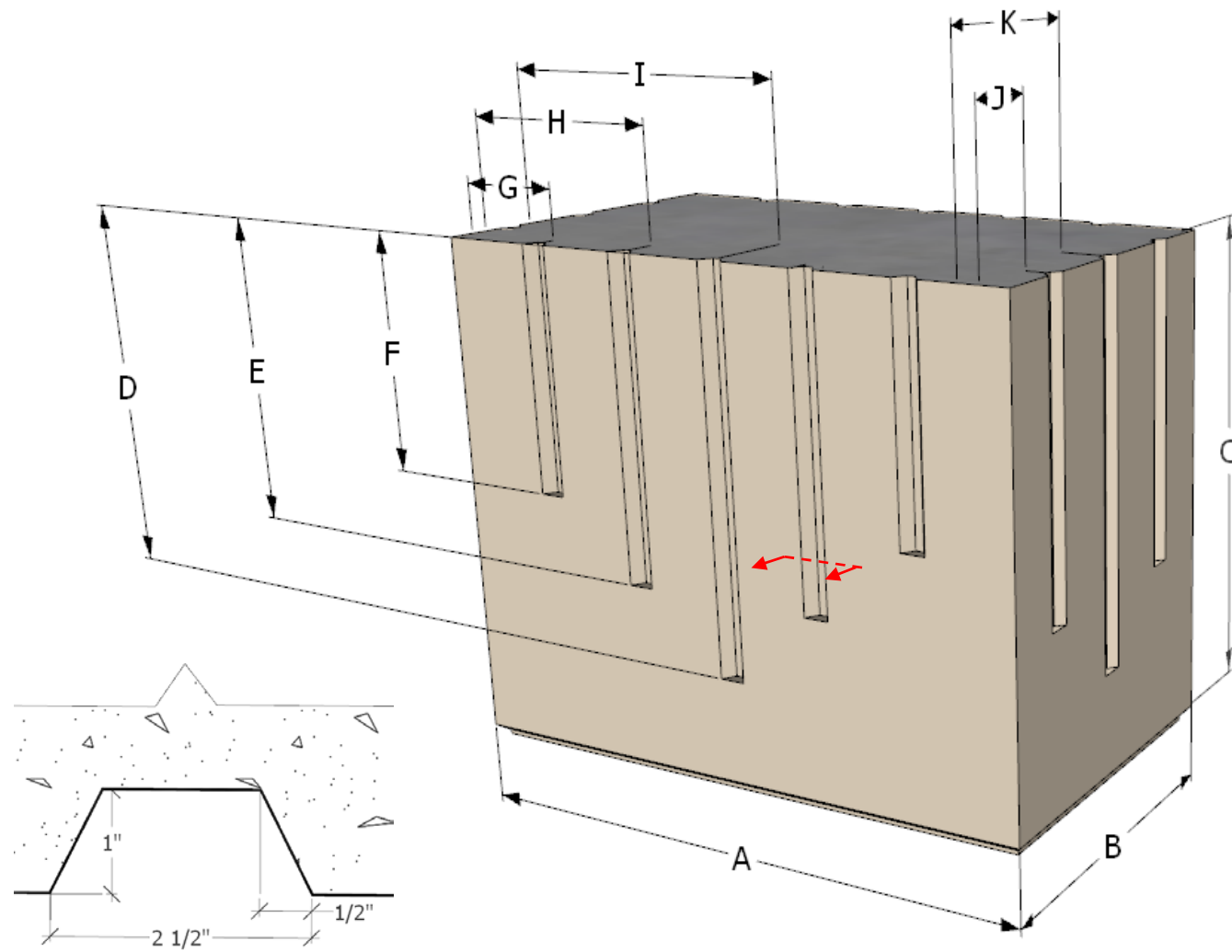

Vertical Reveal Profile

Layout - Decorative Vertical Reveals

Notes

1. Decorative vertical reveal profile to be identical on all structures.
2. Decorative vertical reveals are applied to all faces of support columns in medians and OSB columns
3. Decorative vertical reveals are applied to faces of bridge columns perpendicular to girder lines.
4. Decorative column to receive vertical reveals on outside face only
5. Decorative vertical reveals are omitted on face of outer toll gantry columns closest to tolled lanes
6. See 2.3.0 for outer gantry column section
7. See chart below for column dimensions and reveal dimensional locations
8. Column sizes are preliminary and may be changed in final design with RMA approval

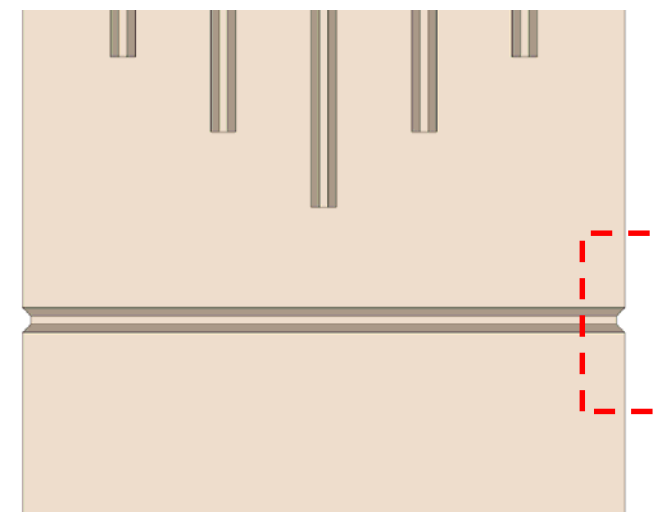

Partial Column Elevation

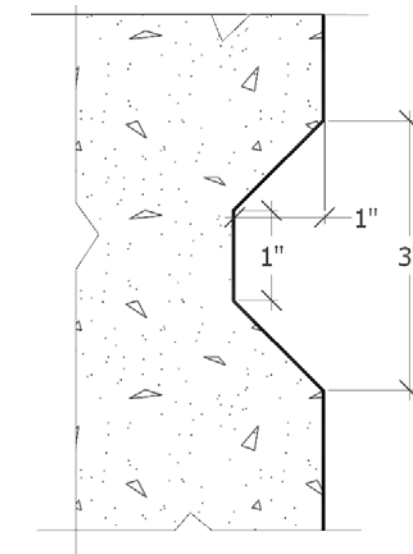

Horizontal Reveal Profile

Bent /Column Type	A	B	C	D	E	F	G	H	I	J	K
OSB Outer & Cantilever Column	6'-0"	3'-6"	5'-0"	4'-0"	3'-3"	2'-6"	1'-0"	2'-0"	3'-0"	10-1/2"	1'-9"
DMS Support Column	6'-0"	3'-6"	5'-0"	4'-0"	3'-3"	2'-6"	1'-0"	2'-0"	3'-0"	10-1/2"	1'-9"
Outer Toll Gantry Support Column	6'-0"	3'-11"	5'-0"	4'-0"	3'-3"	2'-6"	1'-0"	2'-0"	3'-0"	11-1/2"	1'-11 1/2"
Median OSB Support Column	6'-0"	2'-0"	5'-0"	4'-0"	3'-3"	2'-6"	1'-0"	2'-0"	3'-0"	6"	1'-0"
Median Toll Gantry Support Column	6'-0"	2'-0"	5'-0"	4'-0"	3'-3"	2'-6"	1'-0"	2'-0"	3'-0"	6"	1'-0"
Decorative Column	4'-0"	4'-0"	4'-0"	3'-0"	2'-3"	NA	NA	1'-0"	2'-0"	NA	NA
Inverted "T" Twin	6'-0"	4'-6"	5'-0"	4'-0"	3'-3"	2'-6"	1'-0"	2'-0"	3'-0"	NA	NA
Inverted "T" Hammer Head (Double)	10'-0"	10'-0"	8'-0"	7'-0"	6'-3"	5'-6"	1'-8"	3'-4"	5'-0"	NA	NA
Inverted "T" Cantilever Hammer Head	8'-0"	6'-8"	6'-0"	5'-0"	4'-3"	3'-6"	1'-4"	2'-8"	4'-0"	NA	NA
Inverted "T" Hammer Head (Single)	8'-0"	6'-8"	6'-0"	5'-0"	4'-3"	3'-6"	1'-4"	2'-8"	4'-0"	NA	NA
Straddle Bent	8'-0"	6'-8"	5'-0"	4'-0"	3'-3"	2'-6"	1'-4"	2'-8"	4'-0"	NA	NA

Standard Decorative Column Reveal Placement Details

Notes

1. Reveal section to be identical on all structures.
2. Strive to provide consistent horizontal reveal placement within a structure and interchange with multiple structures much as possible. Where variability is needed place variable modules at bottom of column consistently.
3. See chart Dimension "C" on previous page for non- standard Module sizes on select columns

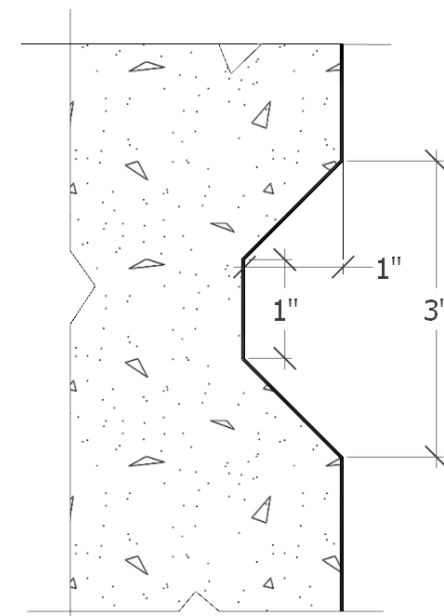
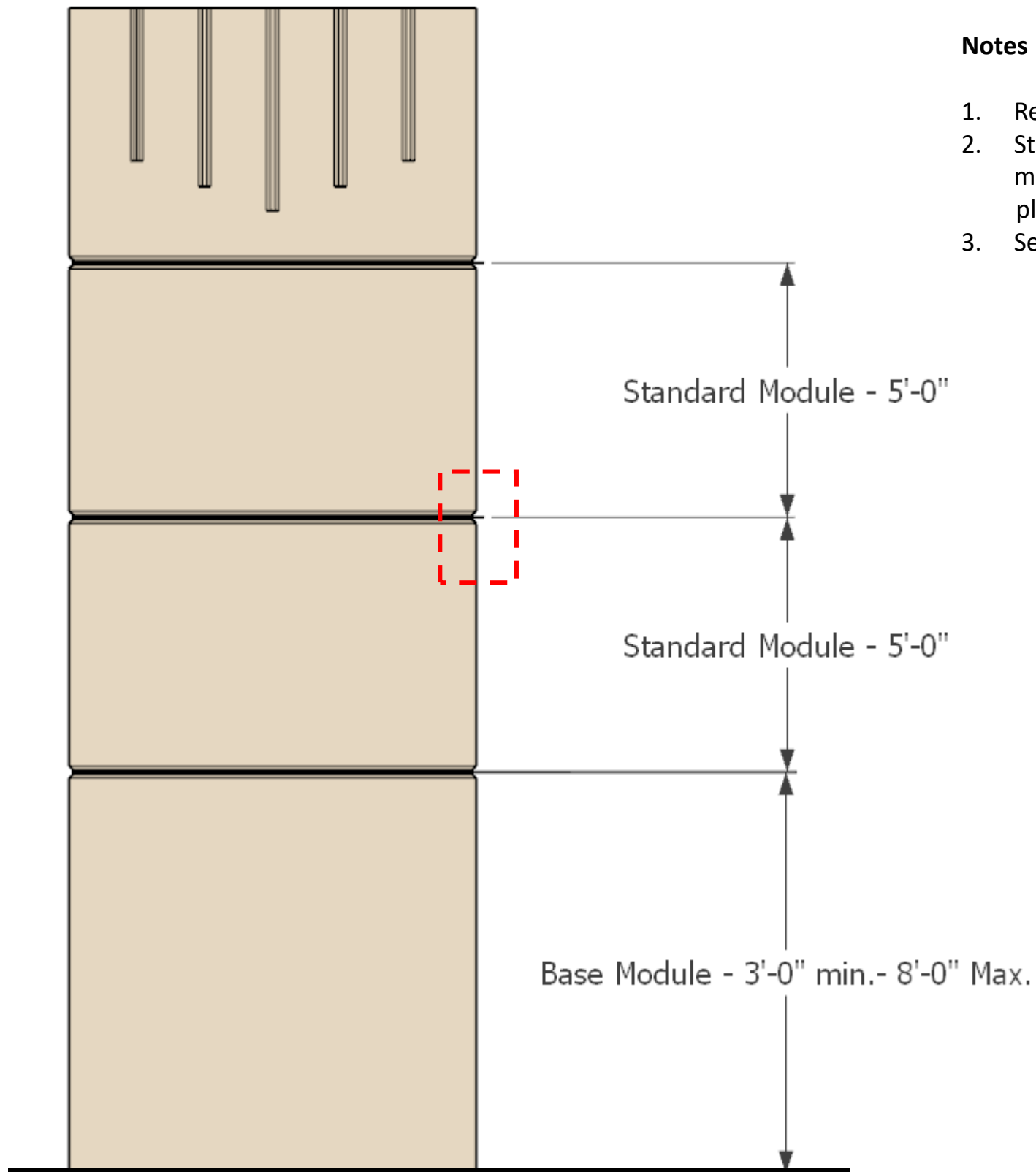

Horizontal Reveal Profile

Column Reveal Layout

Decorative Cap Details

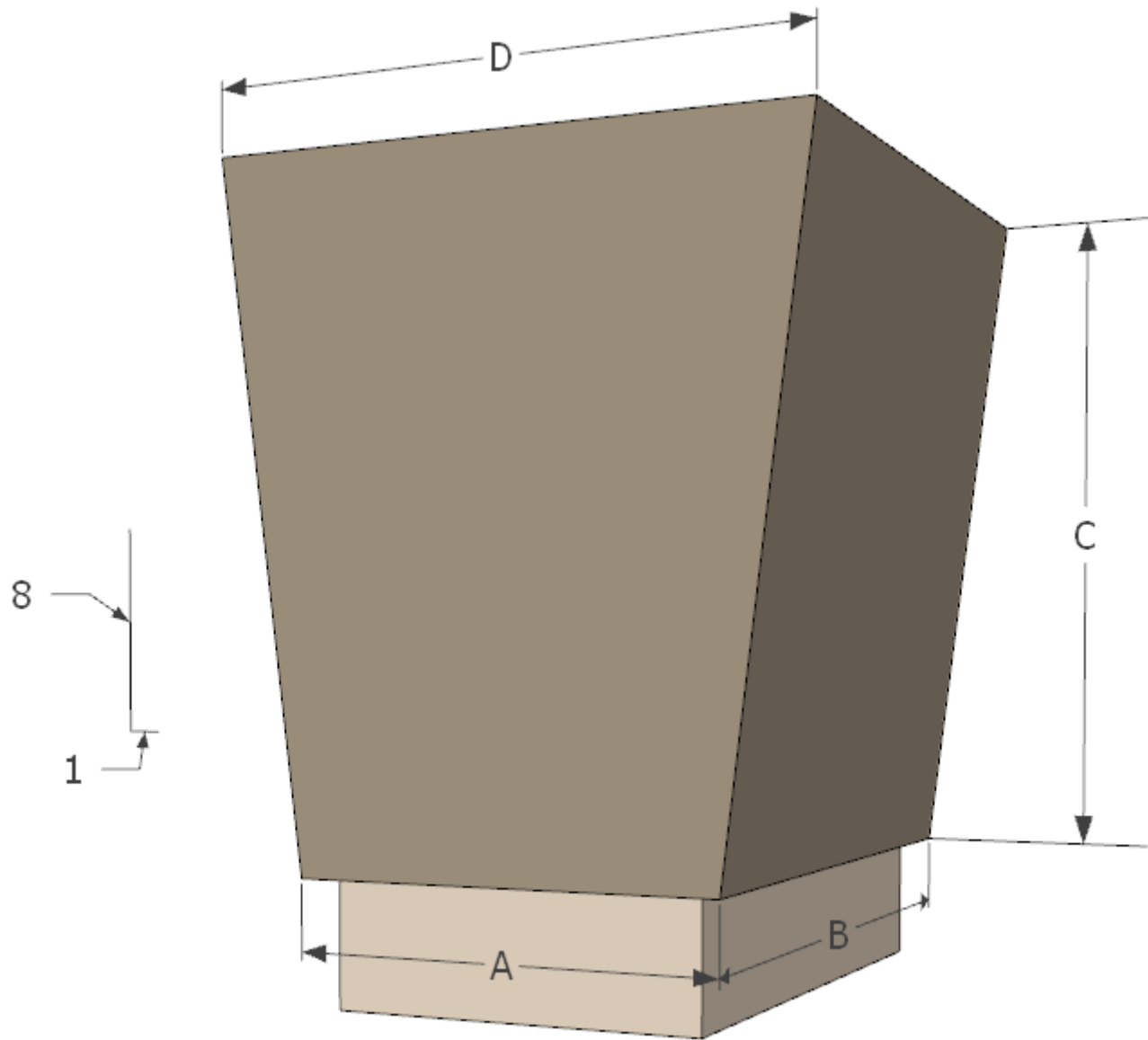

Notes

1. Decorative cap is offset from face of column (each side) 1-1/2" at "A" faces and 3" at "B" faces.
2. "A" represents outside narrower face of cap where occurs
3. Cap is applied to only "A" faces of median OSB and toll gantry columns
4. Cap on decorative column is painted Balanced Beige
5. See chart below for cap dimensions by application
6. 8:1 slope along cap is constant
7. See RID for additional structural details

Decorative Cap Layout

Column Type	A	B	C	D
OSB Exterior /Cantilever Column	4'-0"	6'-3"	6'-6"	5'-7 1/2"
Outer Toll Gantry Support Column	4'-5"	6'-3"	6'-6"	6'-1/2"
Center Median OSB Support Column	2'-6"	NA	5'-0"	3'-9"
Center Median Toll Gantry Support Tower	2'-6"	NA	5'-0"	3'-9"
Decorative Column	4'-6"	4'-6"	5'-0"	5'9"

Inverted "T" Hammer Head Cap Details

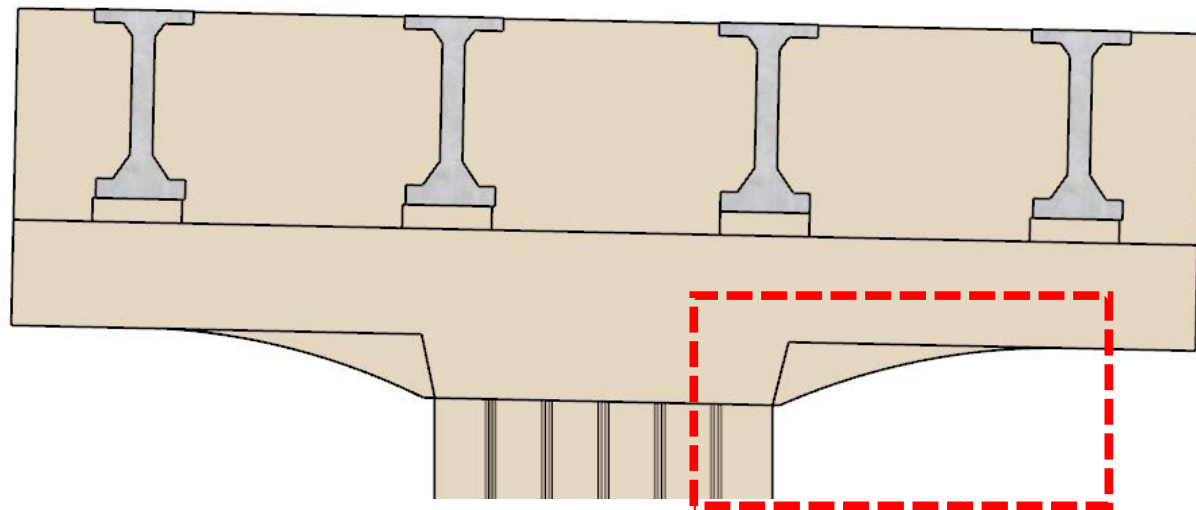

Elevation - Cap

See Detail A

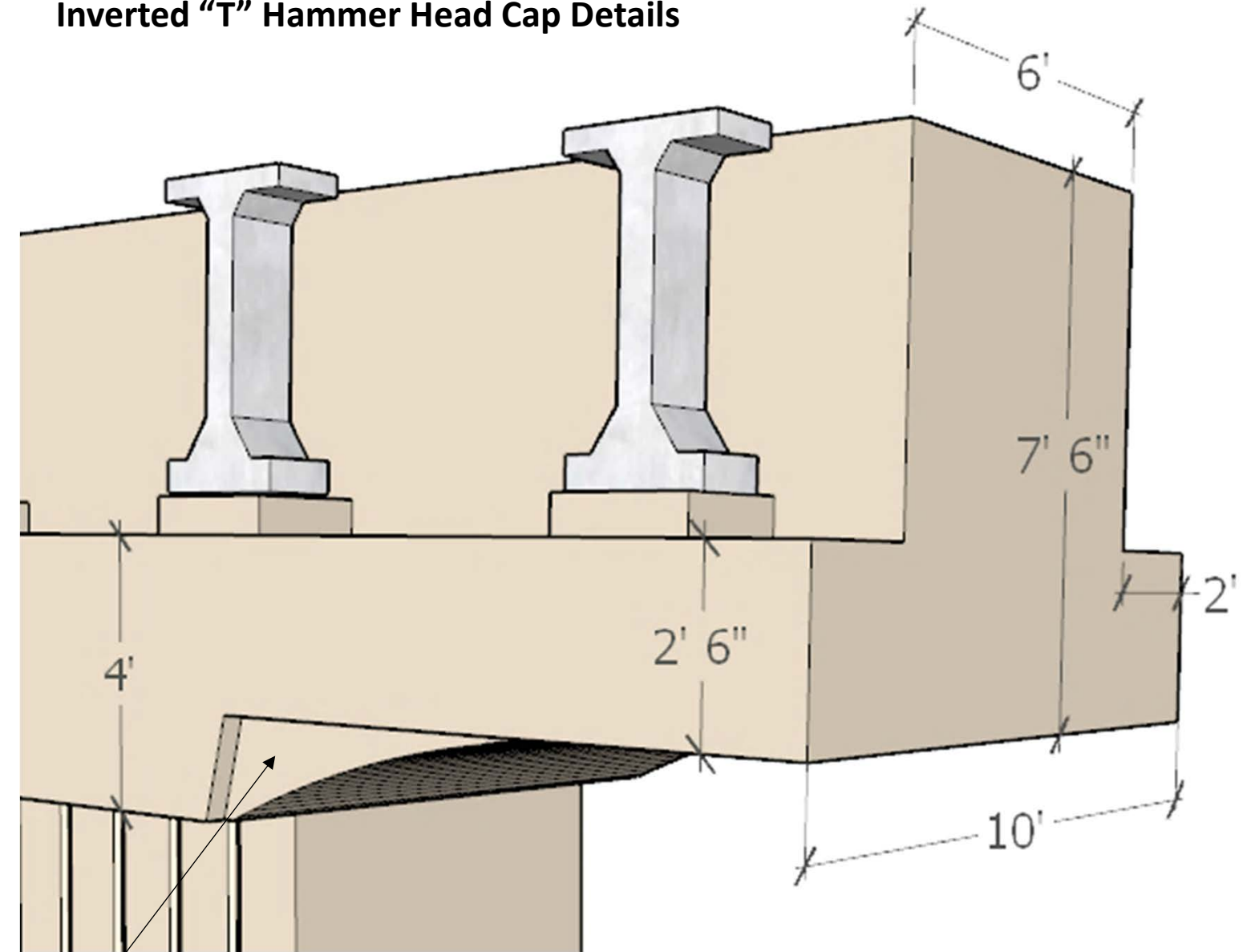

Cap - Partial Perspective View

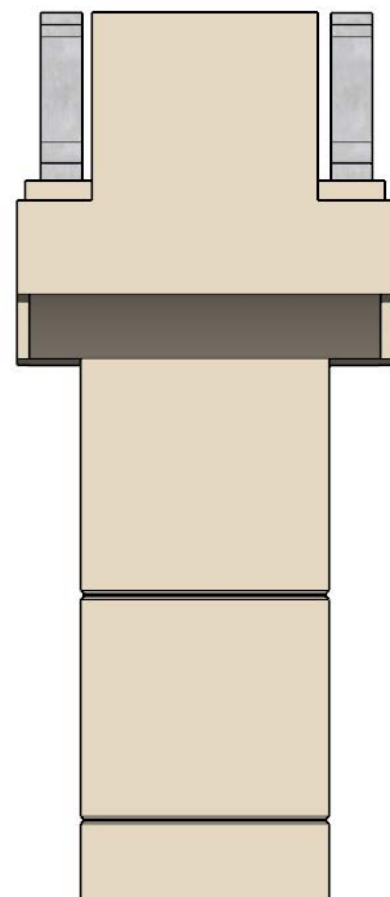

End Elevation - Cap

2" Recess

Notes

1. General Cap Details to be used on both the Cantilever and standard Hammer Head Bent
2. General Cap Details to be used for both Single and Double width Hammer Head Bent
3. Dimensions of cap are subject to final design requirements and approval of the Mobility Authority.

Cap Under Soffit and Face Details

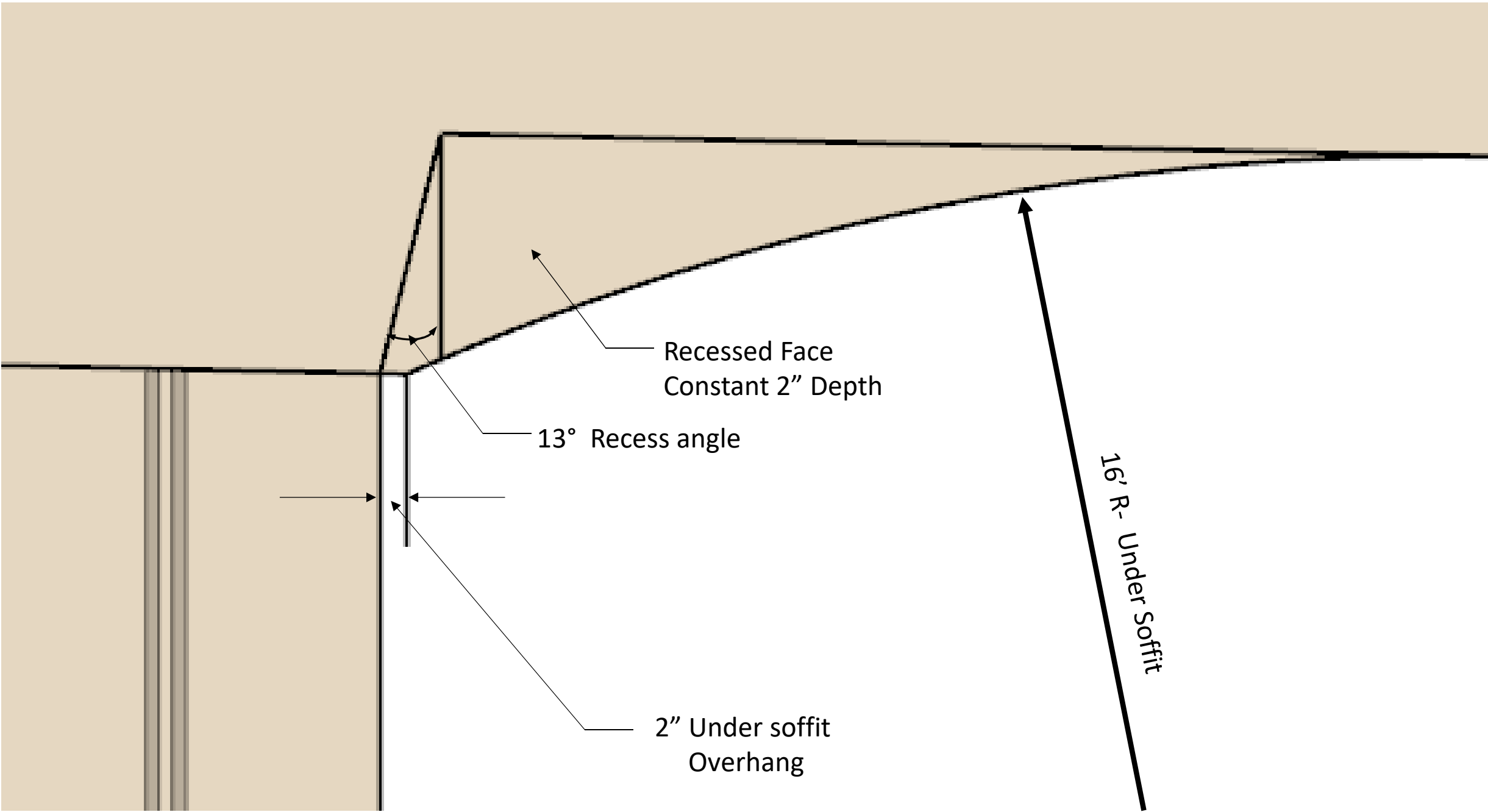

Partial Elevation – Cap Detail A

Notes

- 1. Under soffit Radius to be constant for all caps
- 2. 2" Under soffit overhang be constant for all caps
- 3. Angle of recess on face to be constant for all caps
- 4. Recessed face to be a constant 2" for all caps

Notes

1. Use of the Twin Bent is at the option of the DB Contractor and the Approval of the Mobility Authority in lieu of Hammer Head Bent.
2. Dimensions of Cap are subject to final design requirements and approval of the Mobility Authority.

Inverted "T" Twin- Double Structure Cap

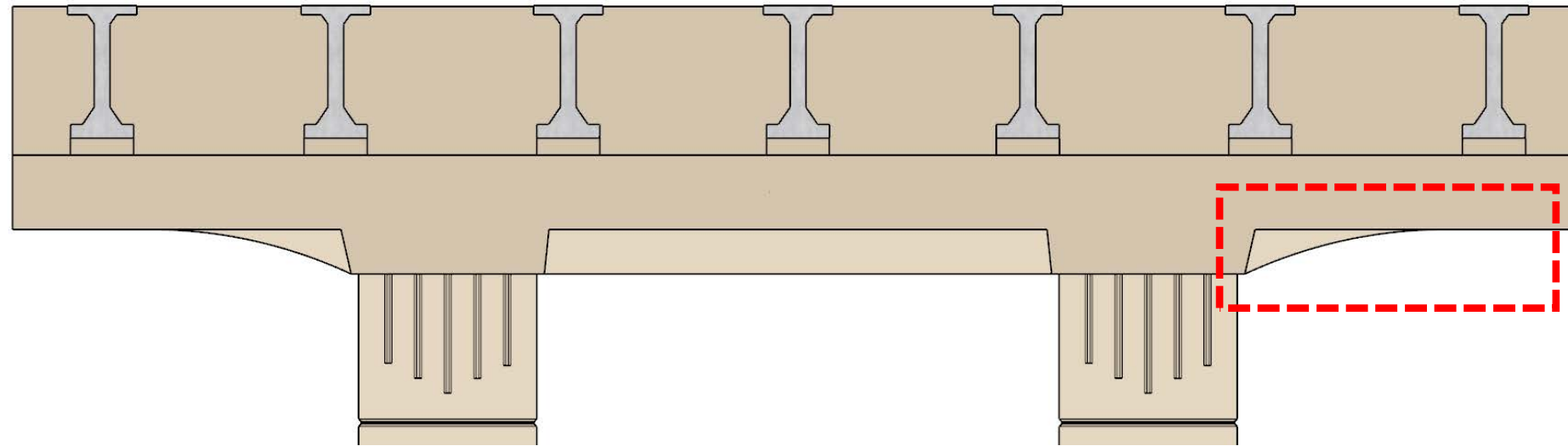

See Detail A

Elevation - Cap

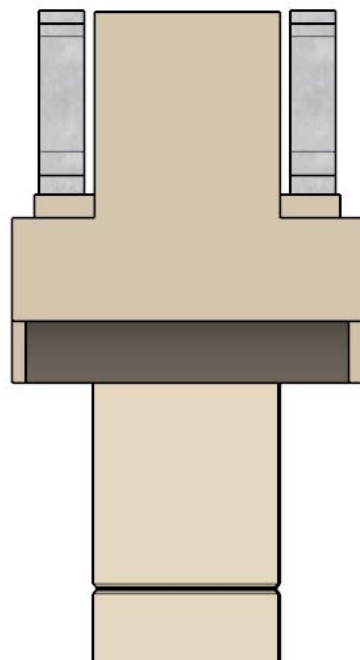

End Elevation - Cap

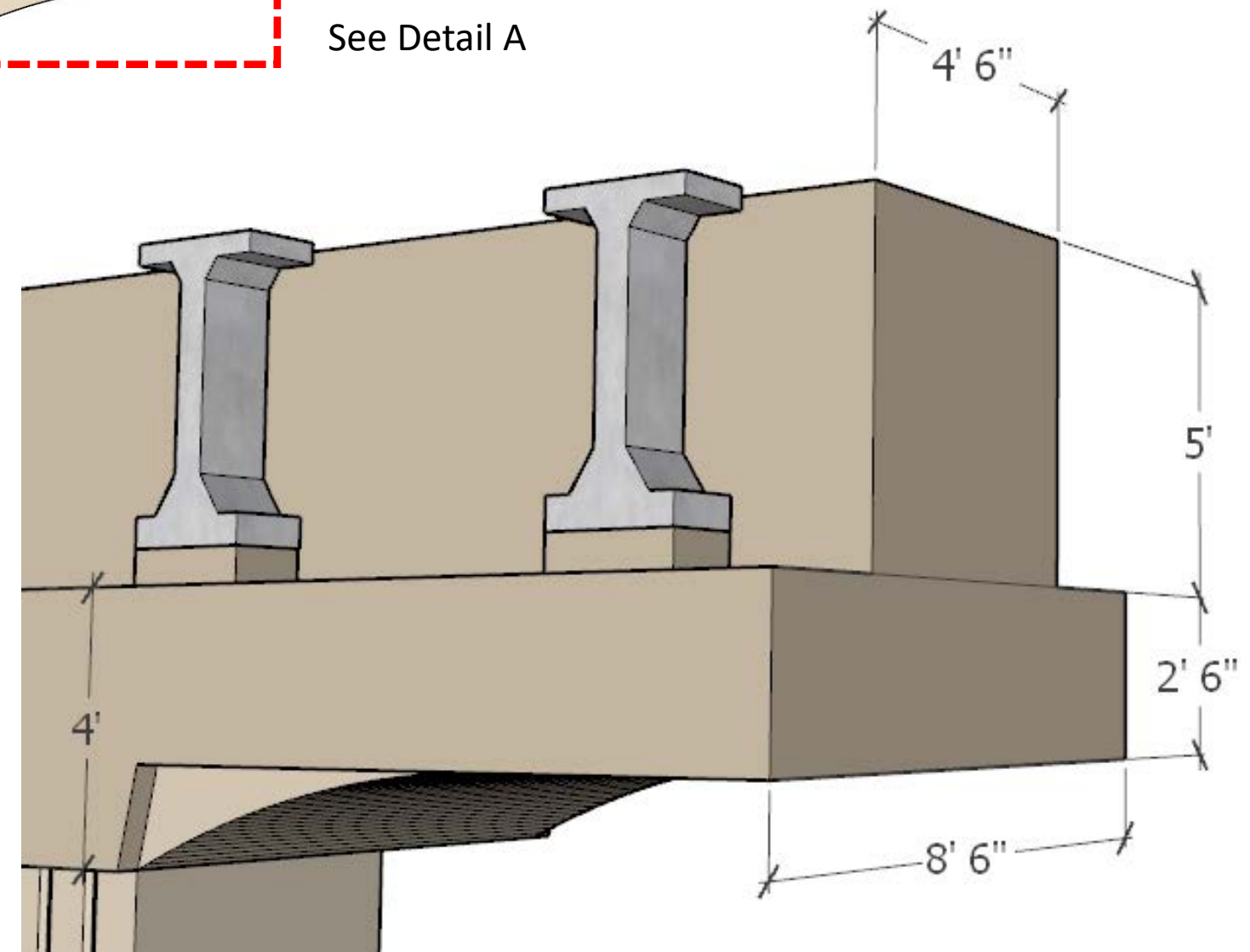

Cap - Partial Perspective View

Notes

- 1. Dimensions of cap are subject to final design requirements and approval of the Mobility Authority.
- 2. Beam shelf recess to be used only for portion of cap where beam support is required

Straddle Bent Cap

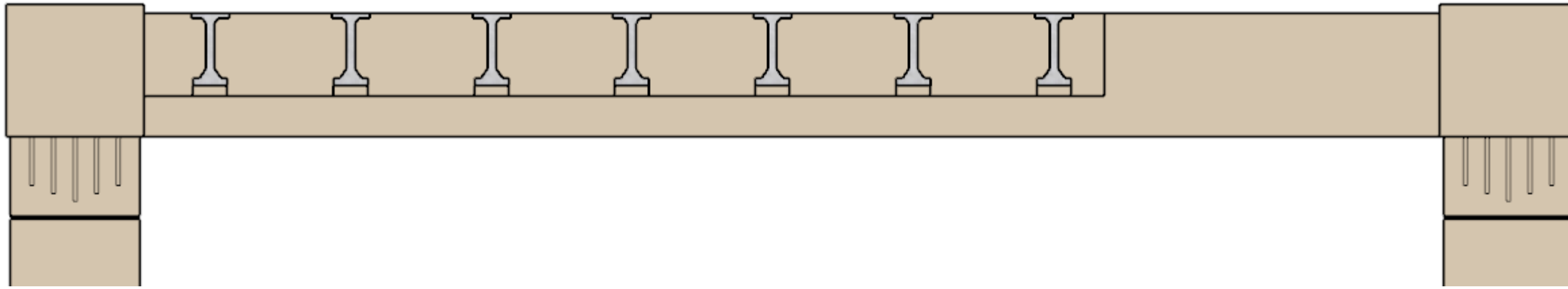

Elevation - Cap

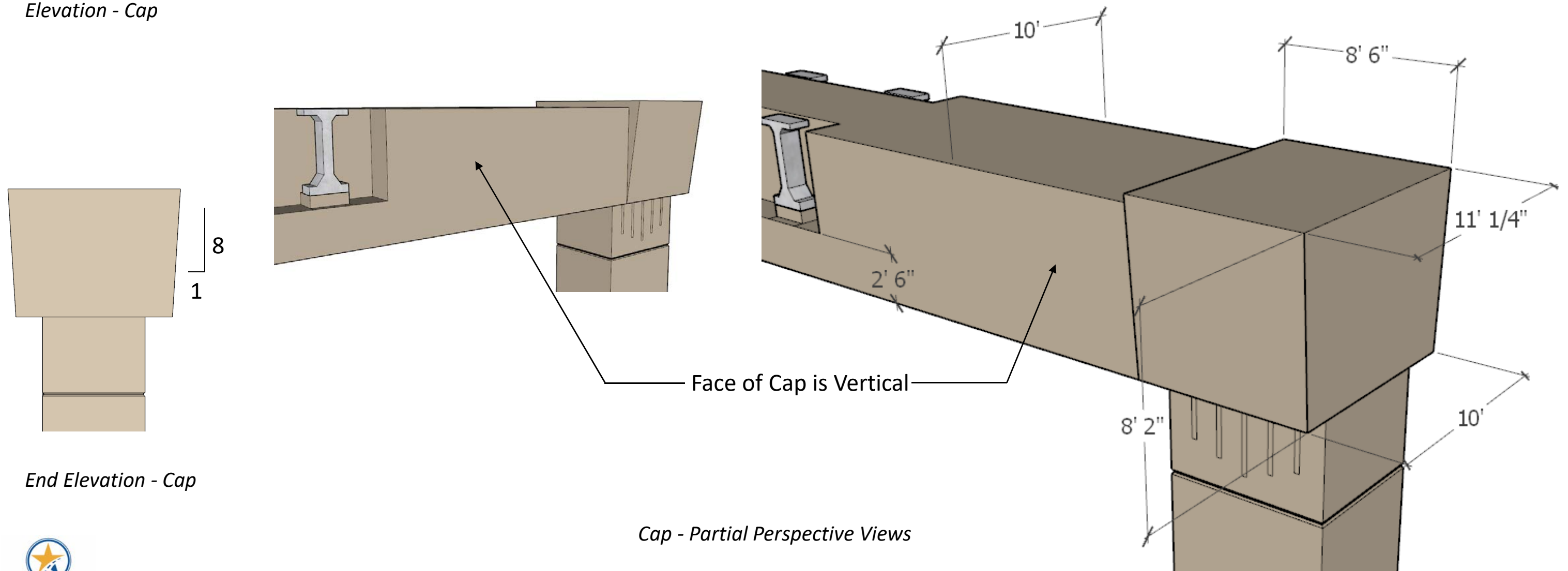

Cap - Partial Perspective Views

Mast Lighting Tower Base Details

Notes

- 1. Concrete mounting base shall emulate the column shape and proportions
- 2. Reduce the size of the base proportionally to the size of the mast pole being supported.

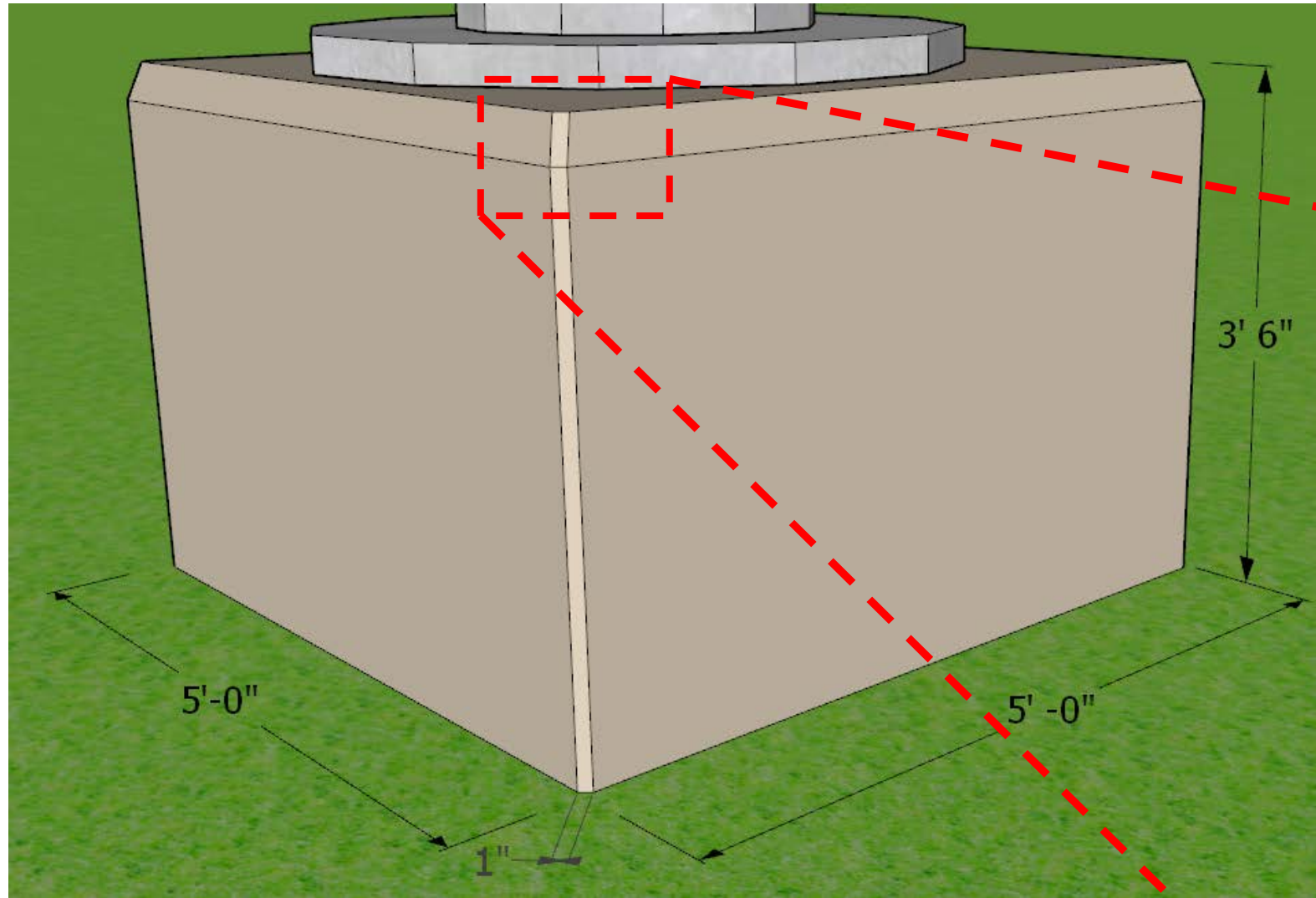

Mast Lighting Tower Base

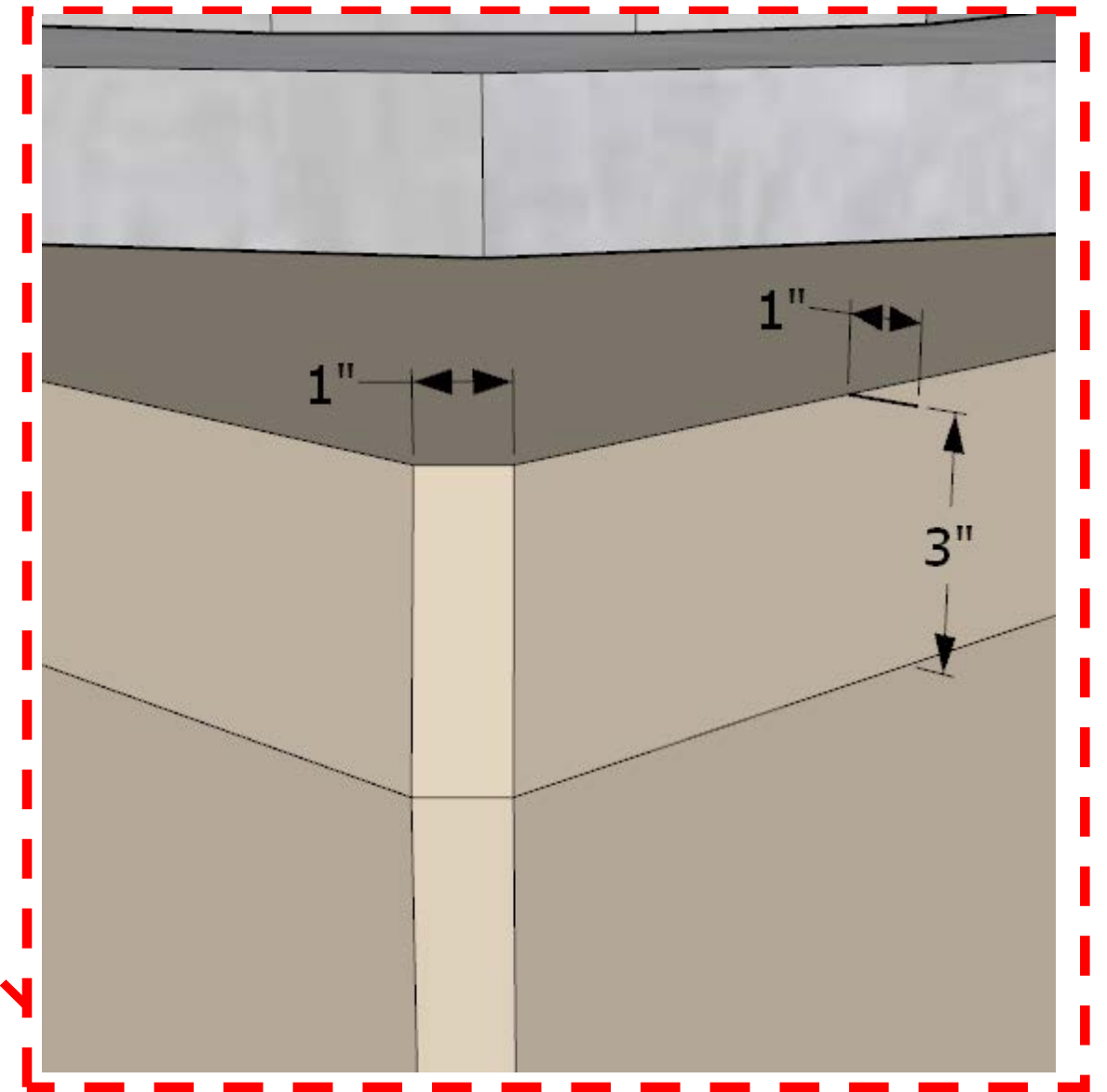

Enlargement of Chamfers along edges of Tower Base

Aesthetic Area 2/Select DC Area 3 - Bridge Painting Details

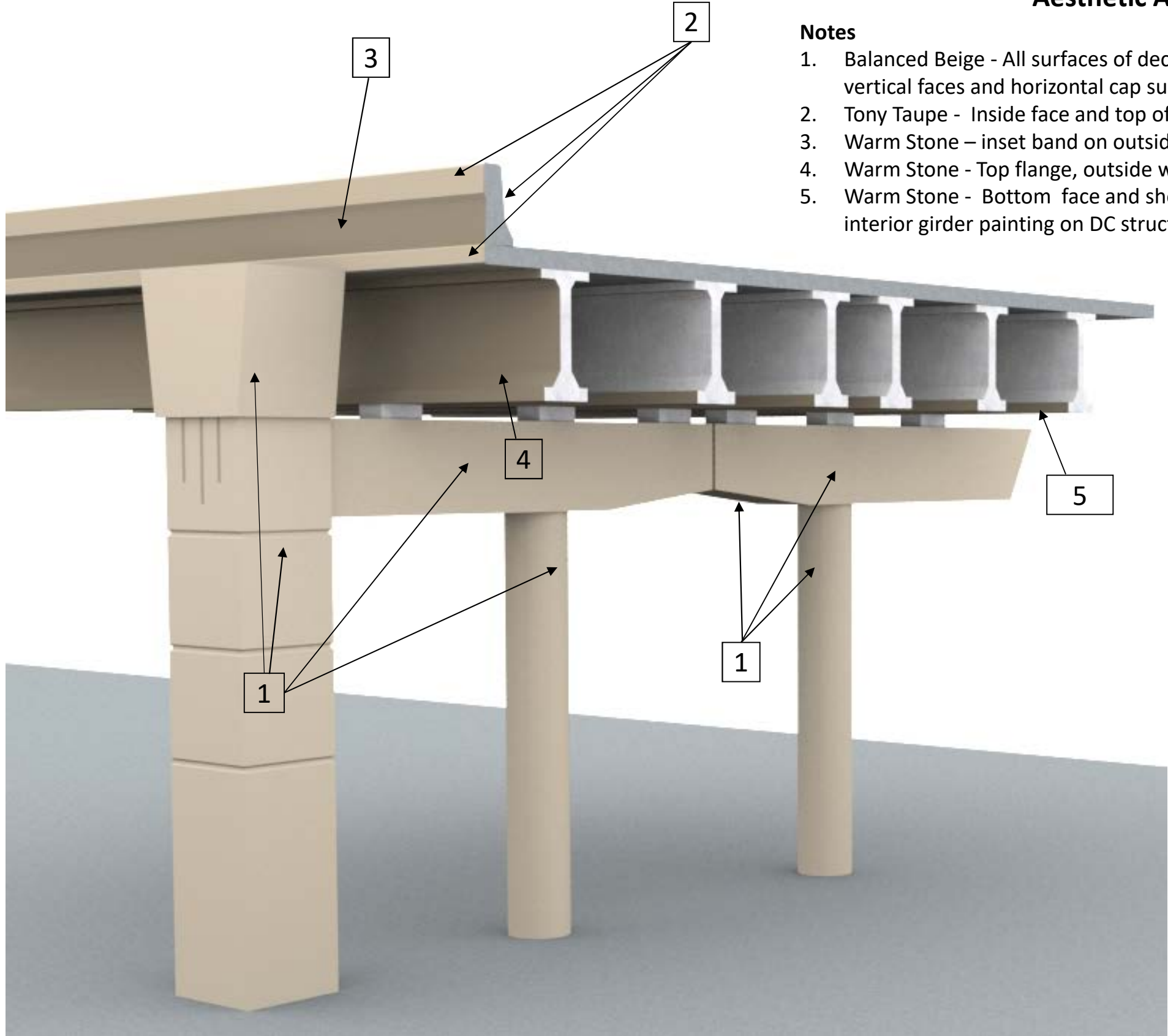

Notes

- 1. Balanced Beige - All surfaces of decorative column and cap, all internal columns and underside, vertical faces and horizontal cap surfaces outside fascia girder.
- 2. Tony Taupe - Inside face and top of Vehicle barrier, exposed top edge and underside of bridge deck
- 3. Warm Stone – inset band on outside face of vehicle barrier
- 4. Warm Stone - Top flange, outside web and bottom flange of Fascia girder.
- 5. Warm Stone - Bottom face and short vertical surfaces of bottom flange of all interior girders – omit interior girder painting on DC structures - Area 3

Retaining Wall Texture Pattern



Braided Ribbon – raked texture

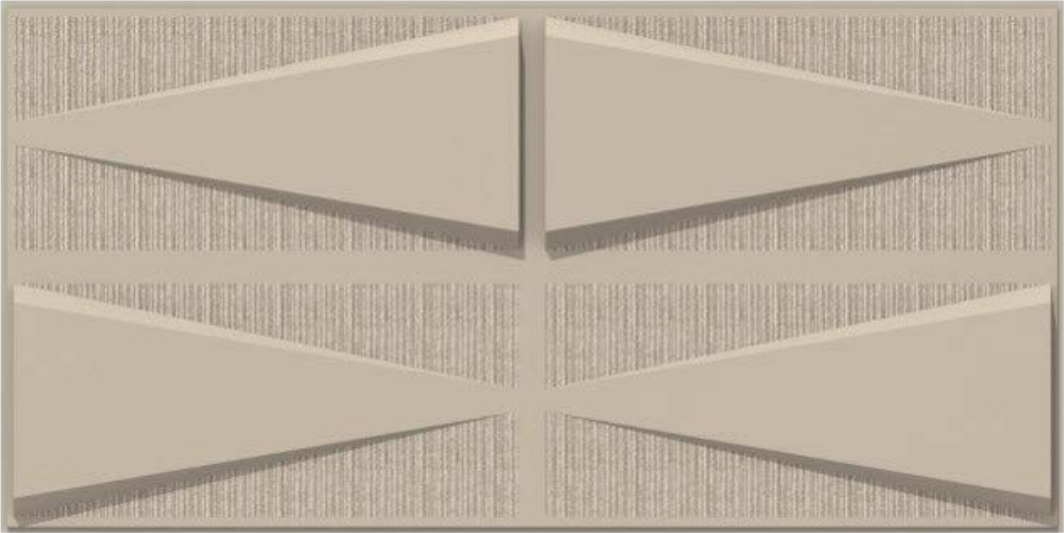

Detail - Positive Relief Panel A

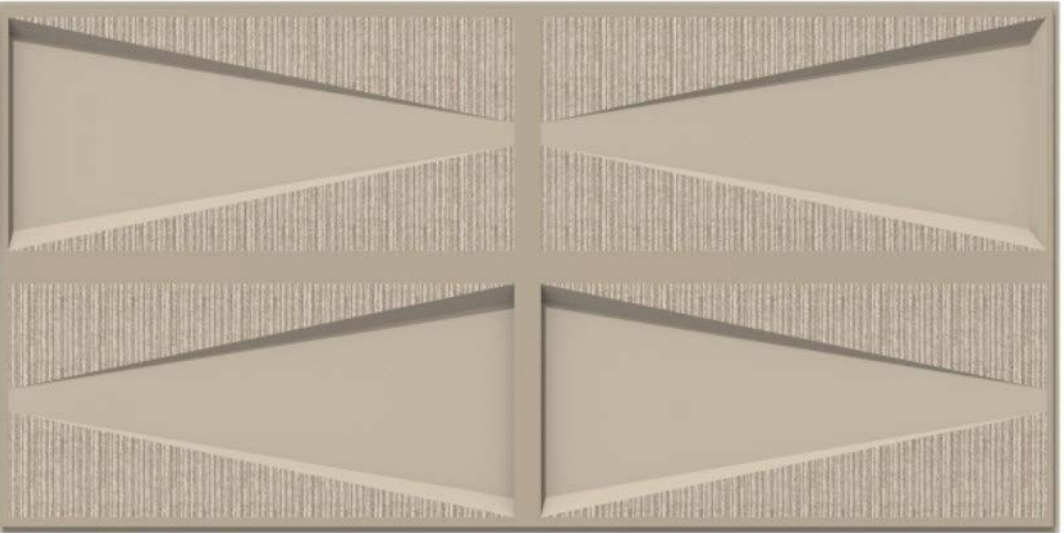

Detail – Negative Relief Panel B

Retaining Wall Texture Pattern Details

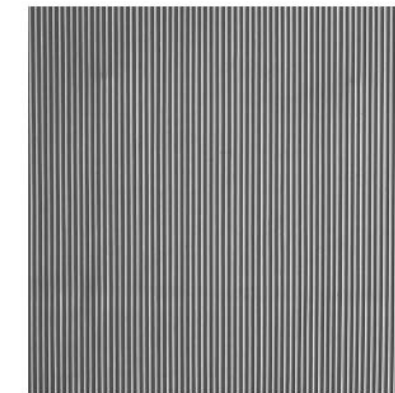

2/63 WISLA

Vertically aligned u-shaped elevations with a smooth surface and a diameter of 10 millimeters.

Background Texture Surrounding Triangles

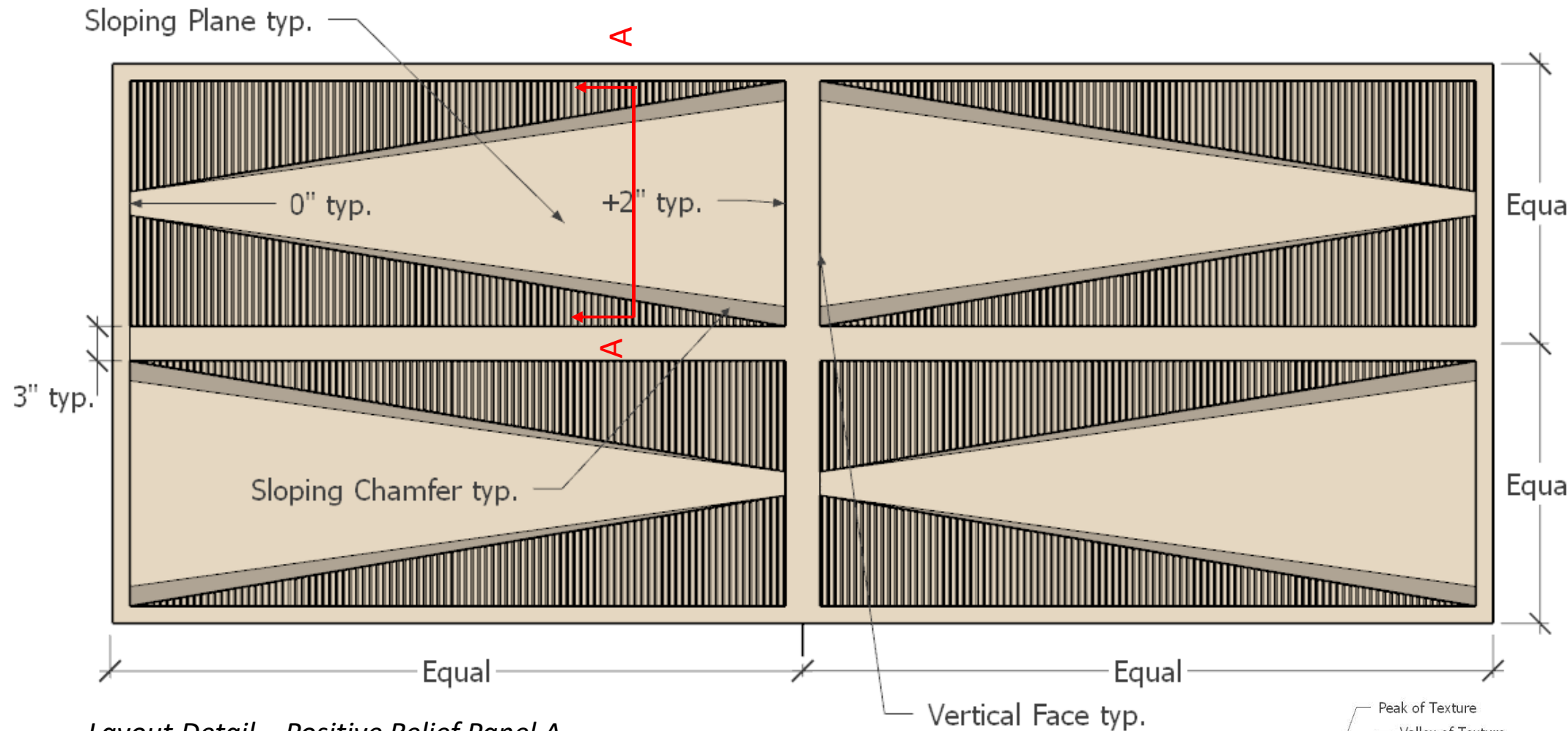

Layout Detail – Positive Relief Panel A

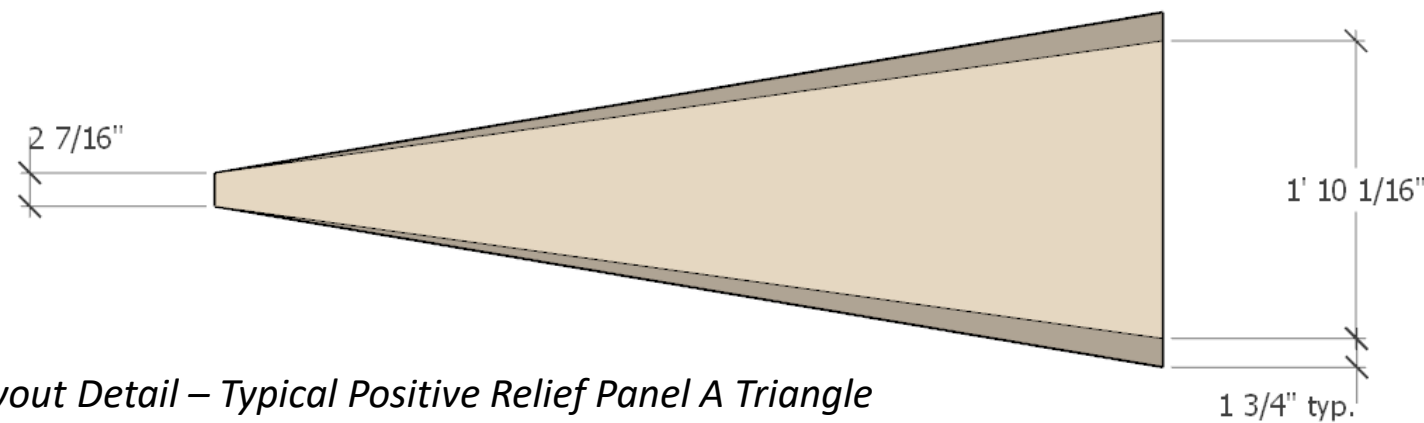

Layout Detail – Typical Positive Relief Panel A Triangle

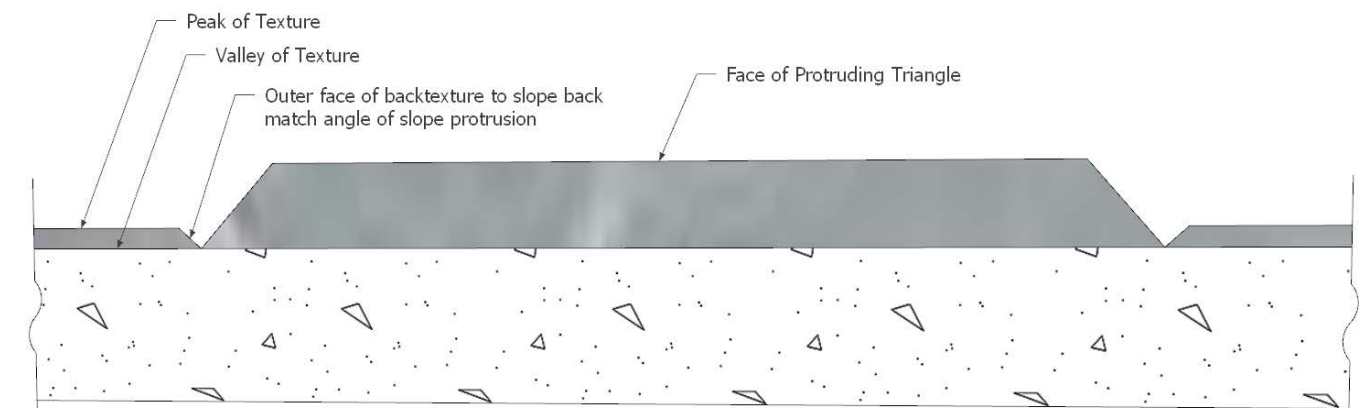

Partial Section A-A – Positive Relief Panel A

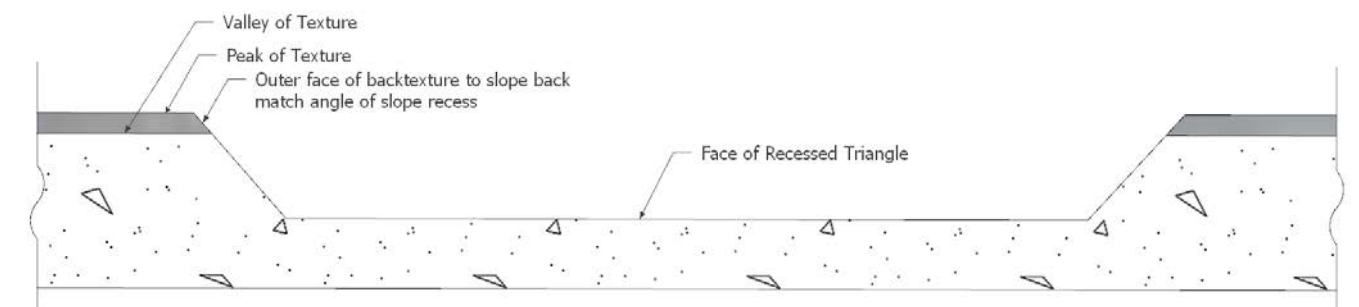

Partial Section A-A – Where Negative Relief Panel B

Notes

1. Layout of Negative Relief Panel B is reverse of Positive Panel A in that the Triangles are recessed into the panel the same depth as the positive Triangles protrude from the panel.
2. The background texture pattern is positioned identically on both Panels A and B

Retaining Wall Slip Joint Cover Details

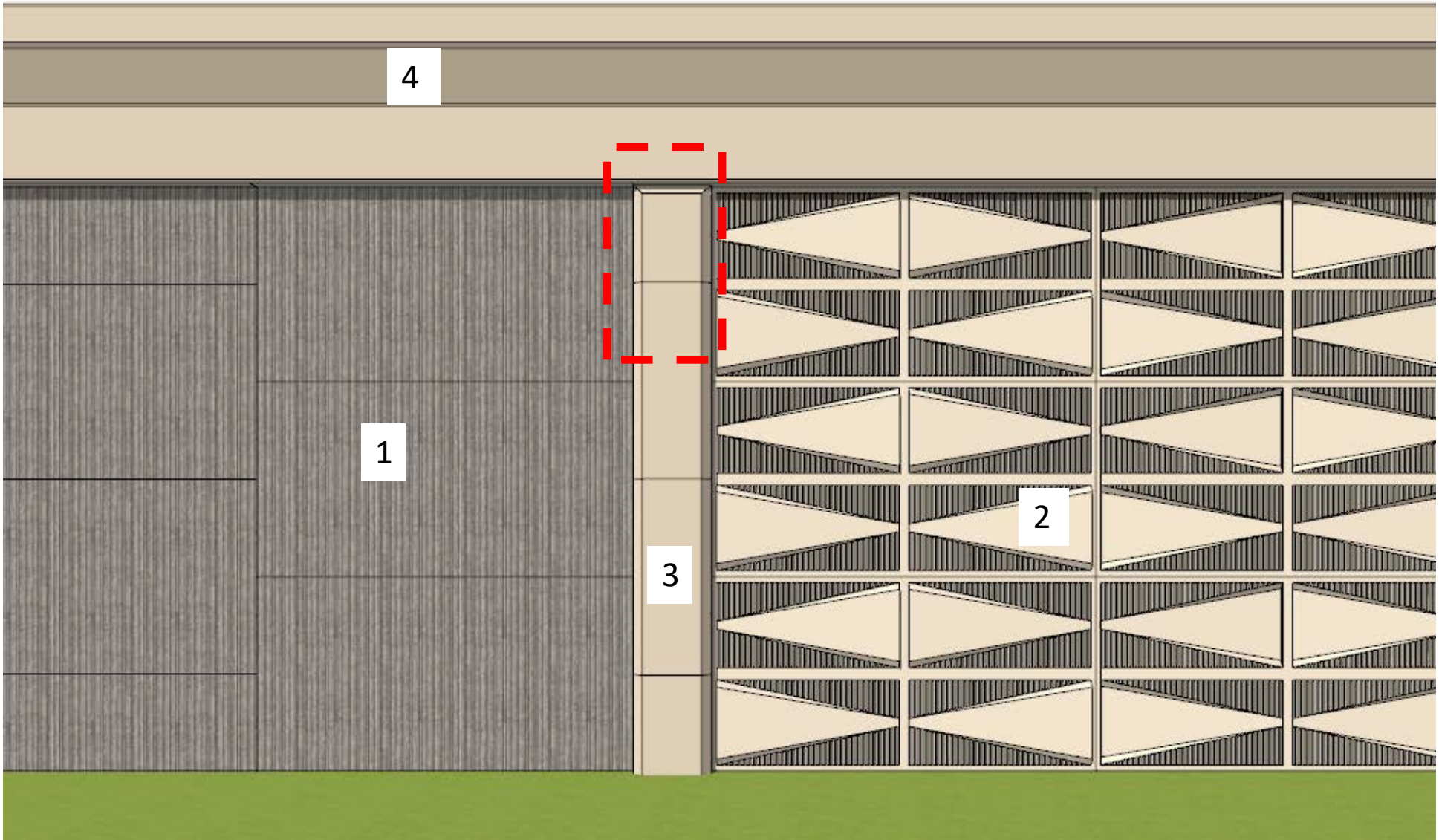

Elevation - Slip Joint Cover

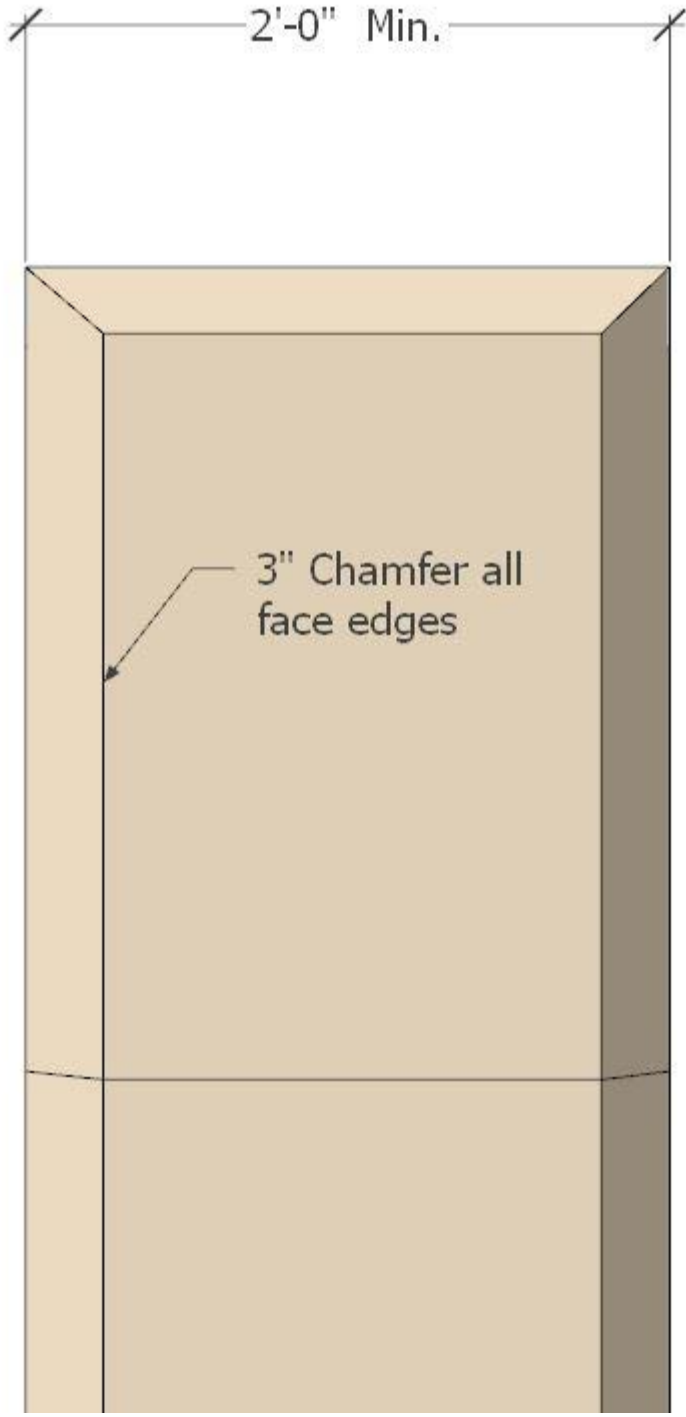

Elevation - Slip Joint Cover Details

Notes

- 1. Existing retaining wall to remain, clean only
- 2. New 183 North Mobility retaining wall - Balanced Beige
- 3. Slip Joint Cover painted to 183 North Mobility Project standards - Tony Taupe
- 4. Coping and vehicle barrier painted to 183 North Mobility Project standards- Tony Taupe with Warm Stone accent band

Abutment Wall and Coping Details



Vertical Abutment Notes

1. Abutment Panels to be smooth surface
2. Abutment Corners and Coping Elements to have smooth surfaces
3. Coping and Corners to include 183 North Mobility Project Decorative Reveals Pattern on Exposed Faces and Ornamental Caps at Corners
4. See RID documents for special corner coping, pilaster and accent details

Special Corner Coping and Pilaster

Special Coping Accent

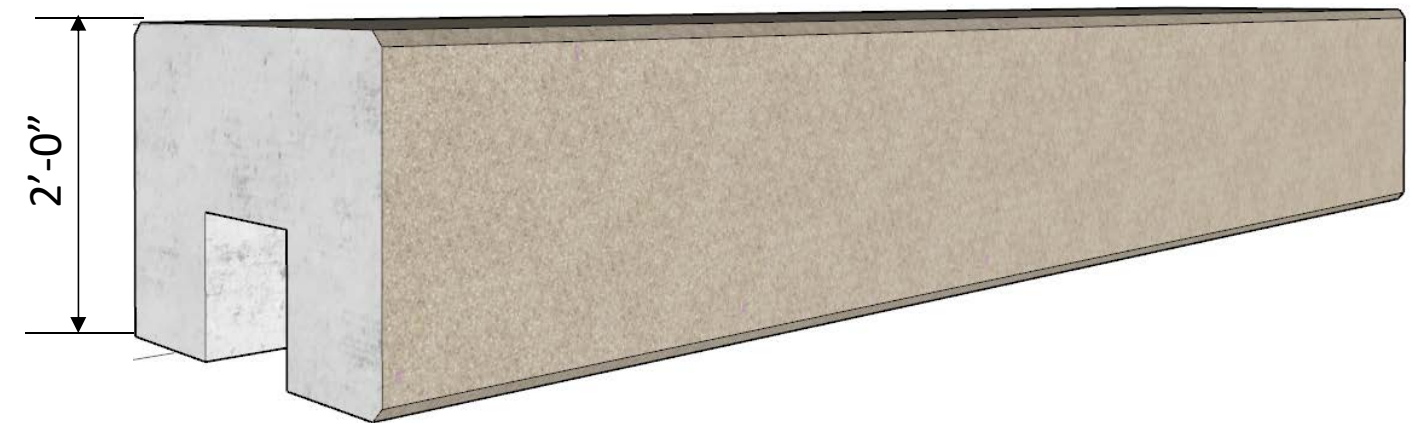

Coping Notes

1. Wall coping to be precast to the greatest extent possible.
2. Cast-in-place coping to match chamfer, texture and dimensions of pre-cast coping units
3. All top and bottom exterior coping edges to be chamfered
4. Coping to be smooth form finish
5. Coping width to be per fabricator standards

Vertical Abutment

Vehicle Safety Barriers

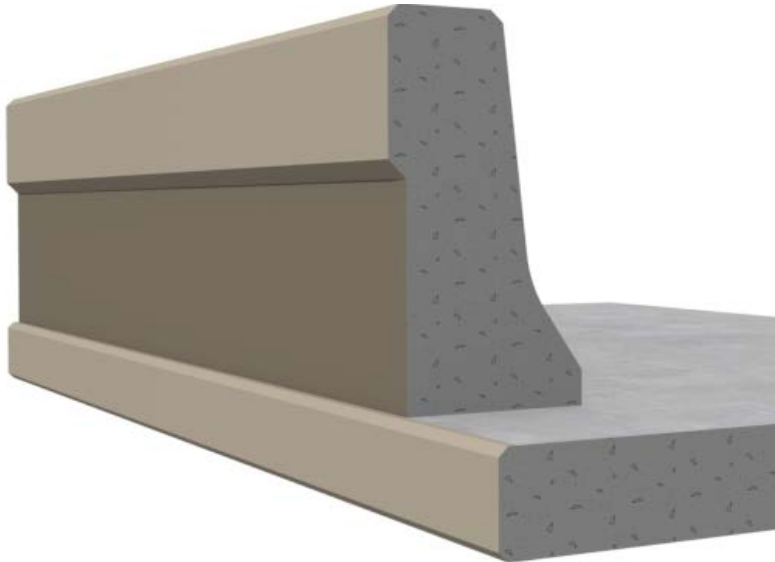

T551—Exterior bridge deck and retaining walls near travel lanes

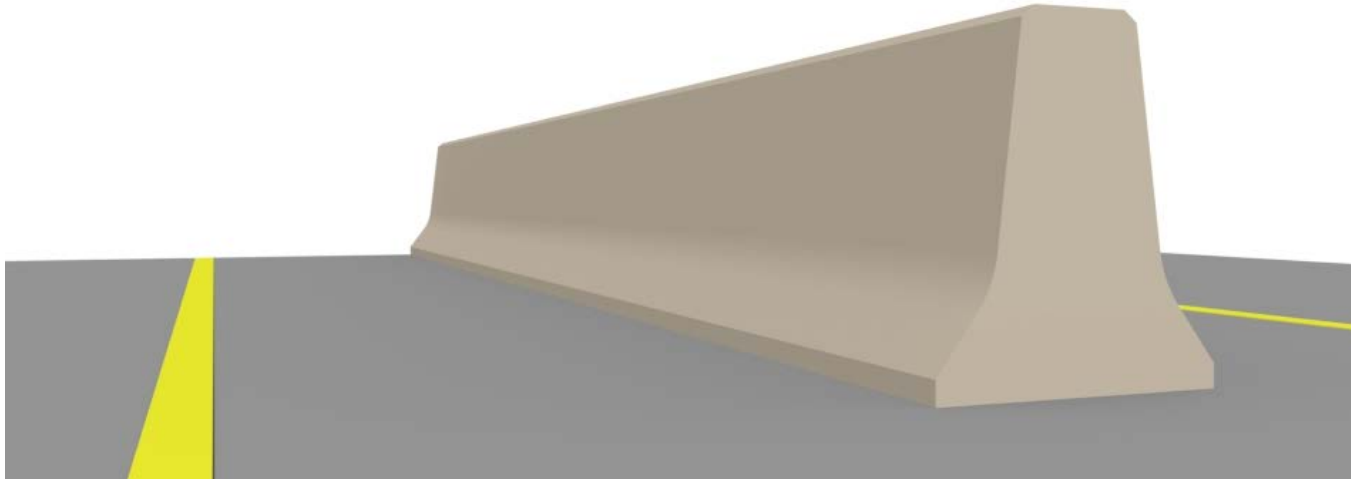

CSB – Opposing lane separation - At grade and on structures

Storm Water Basin Fencing



Perspective

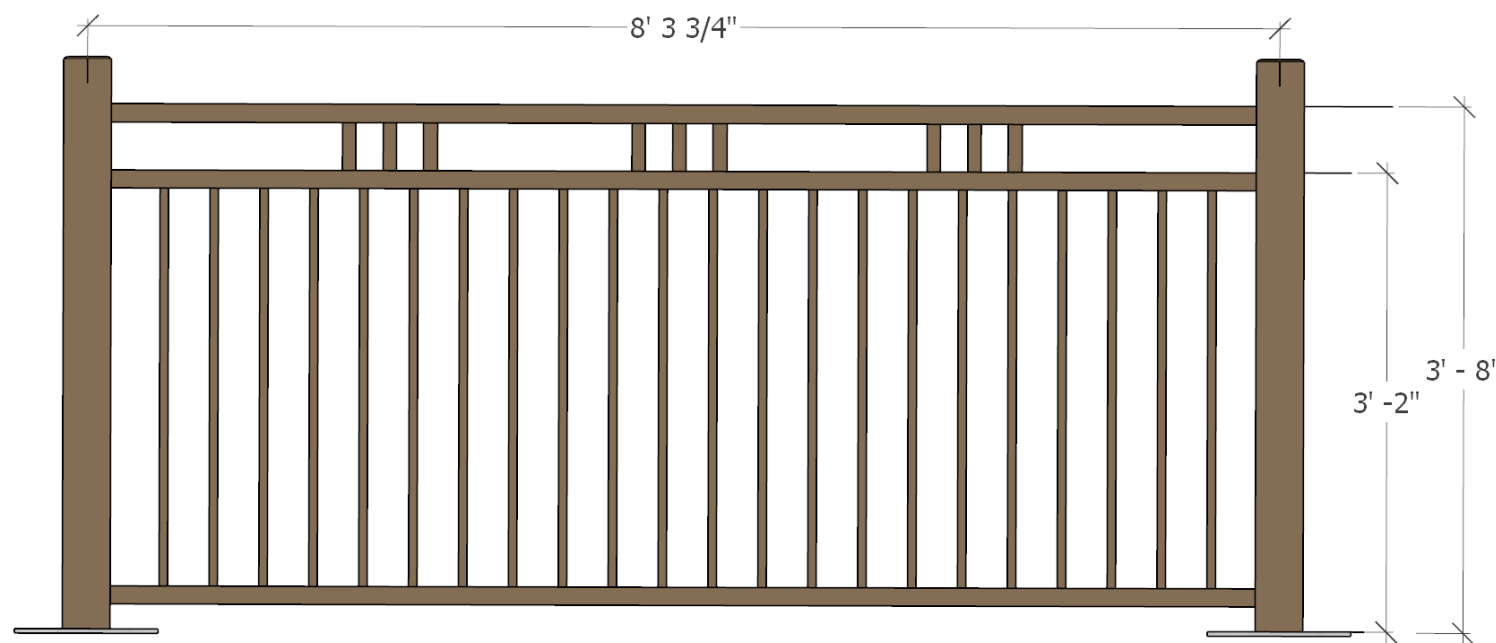

Elevation - Decorative Fence

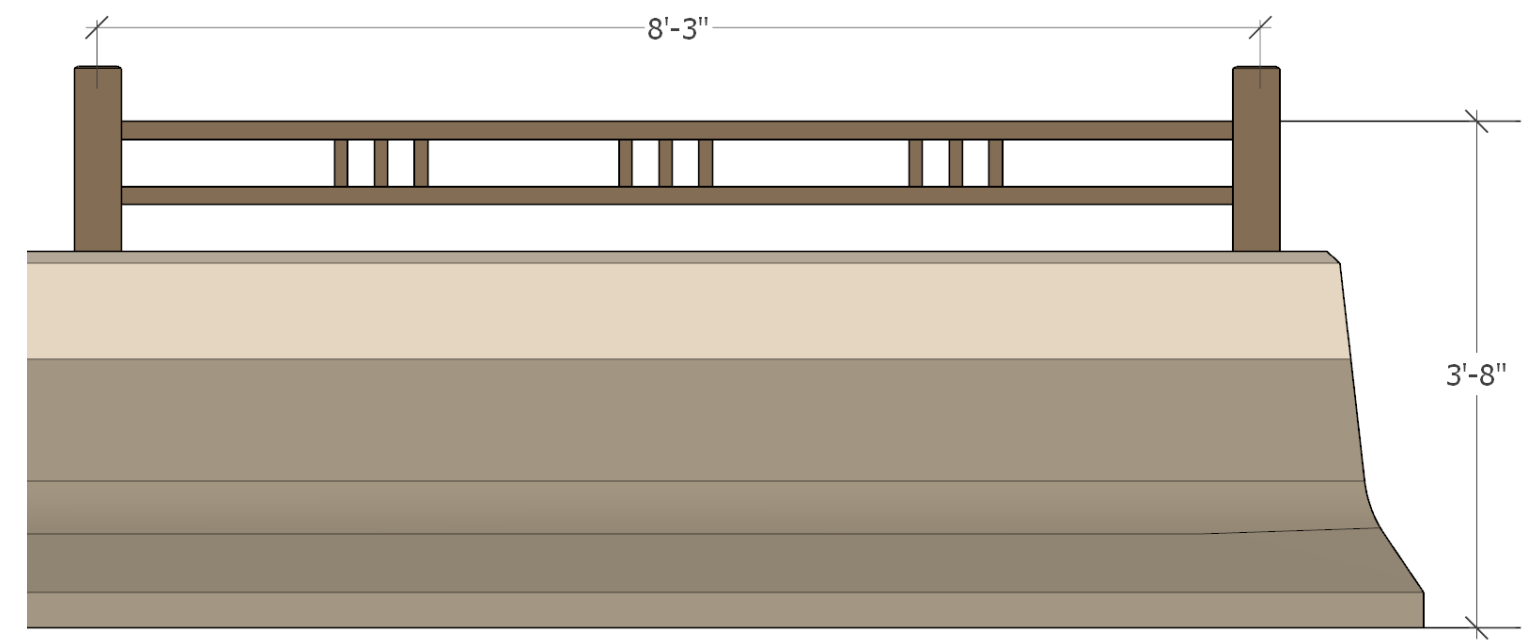

Elevation - Concrete Barrier with Decorative Rail

Notes

1. Decorative fence and railing to be fabricated of tubular steel and powder coated
2. Decorative fence to be used around storm basins in areas of high visibility and near pedestrian access.
3. Where vehicle protection is required, combination concrete vehicle barrier with decorative railing may be used.
4. Fencing at locations which are not highly visible shall be standard chain link fencing with brown PVC coating.

Notes

1. Interchange plaza pavement to be poured-in-place concrete using either
 - integral color admixture or:
 - surface applied dry shake color hardener
2. All pavement to receive medium broom finish
3. Saw cut existing pavement to facilitate installation of new decorative paving.
4. Restore infield pavement using reclaimed pavers where appropriate.
5. See Color Matrix for pavement colors
6. See Cap Ear Wall Details for widening where conflicts occur with U-turn roadways (locations at Red Dashed Inset below)

**Pond Springs Rd./McNeil Dr.
Interchange Plaza Pavement**

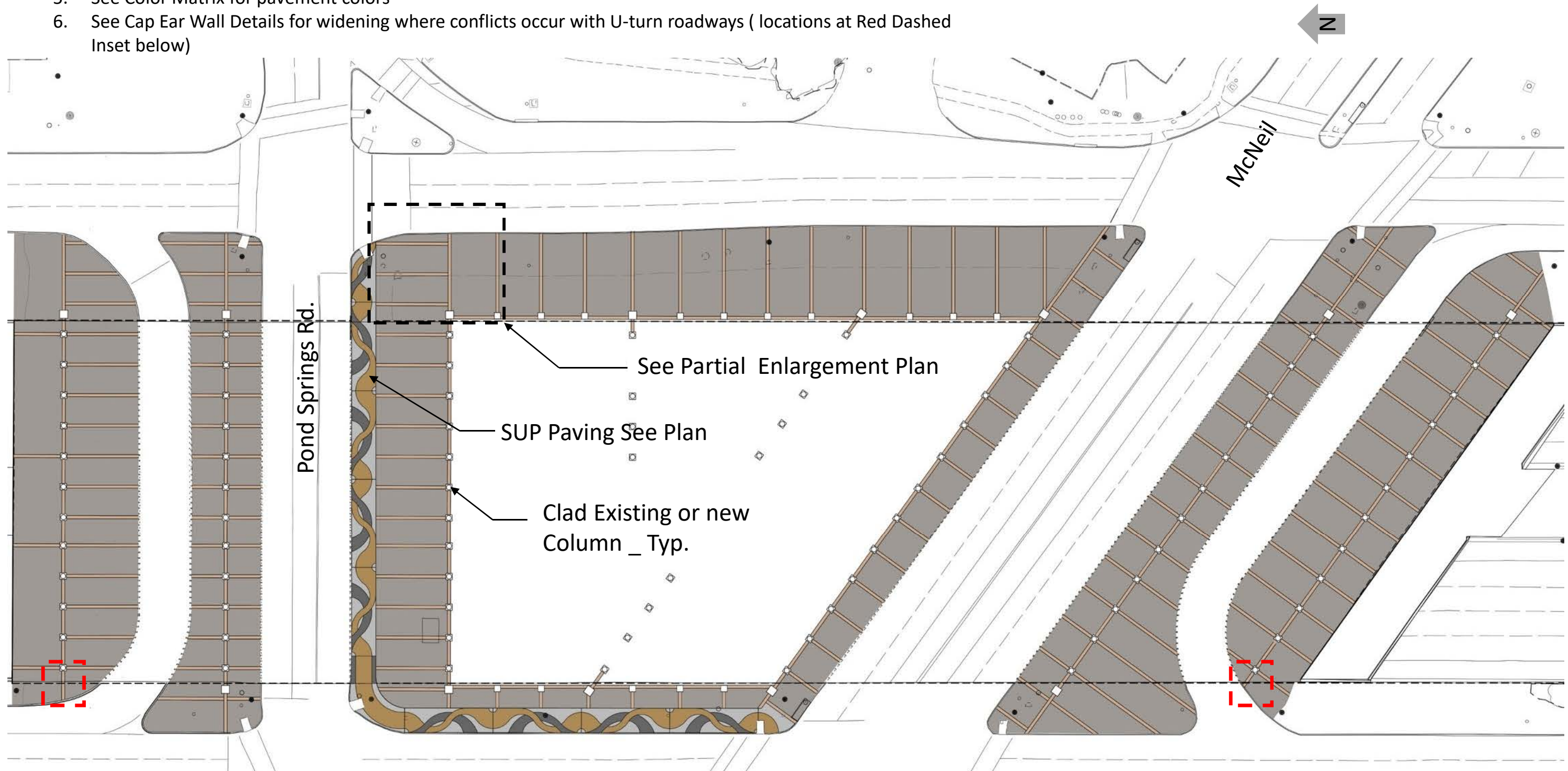

Plan – Pond Springs Rd./McNeil Dr. Interchange Plaza Pavement

**Pond Springs Rd./McNeil Dr. Interchange
Plaza Pavement Details**

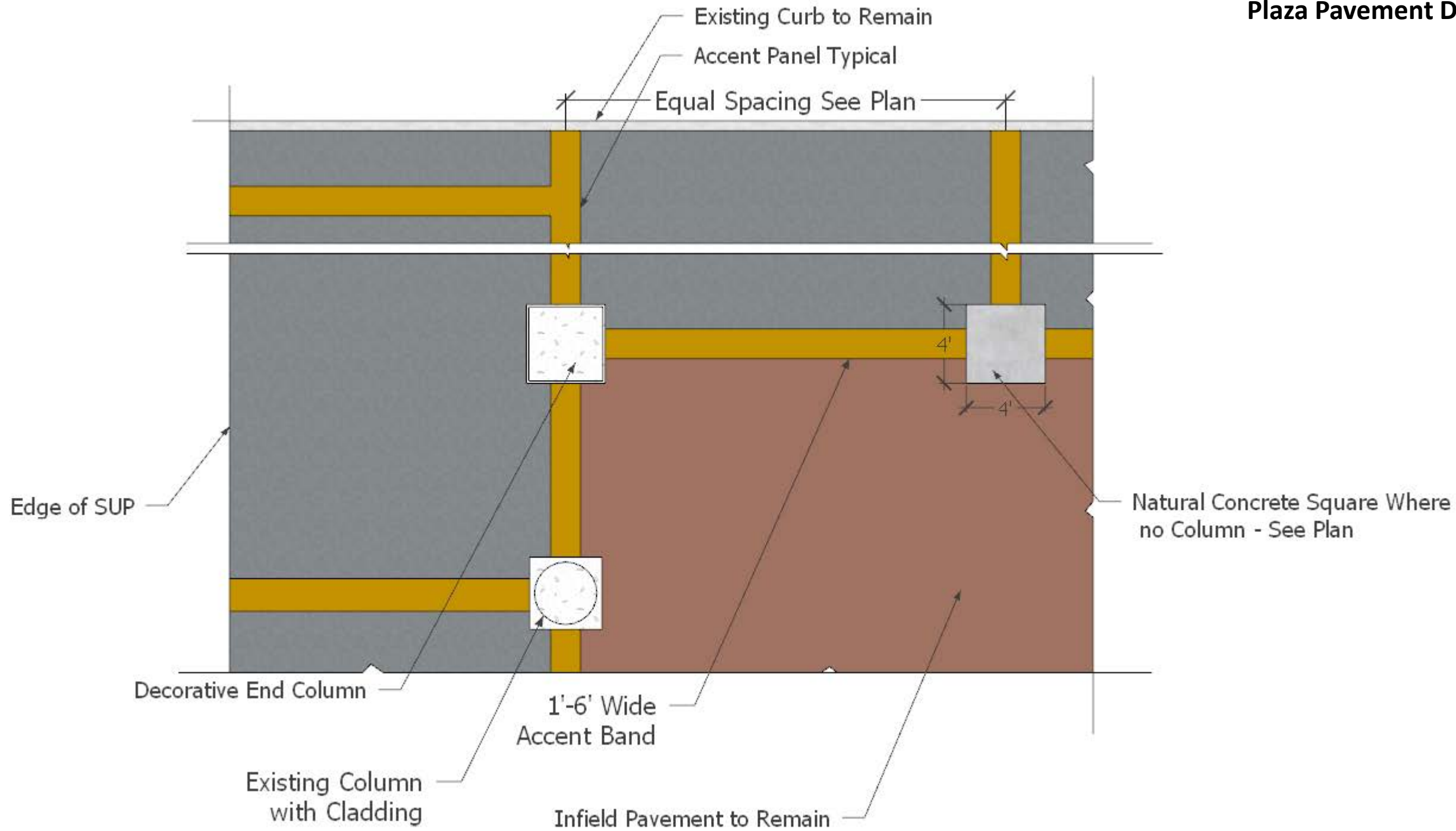

Partial Enlargement Plan

Notes

1. Infield pavement to be retained/ restored using salvaged materials where applicable.
2. Saw cut clean line in concrete pavement where occurs to facilitate installation of new decorative pavement.
3. New plaza pavement to match existing grades of pavement to be removed and replaced.

SUP Special Pavement

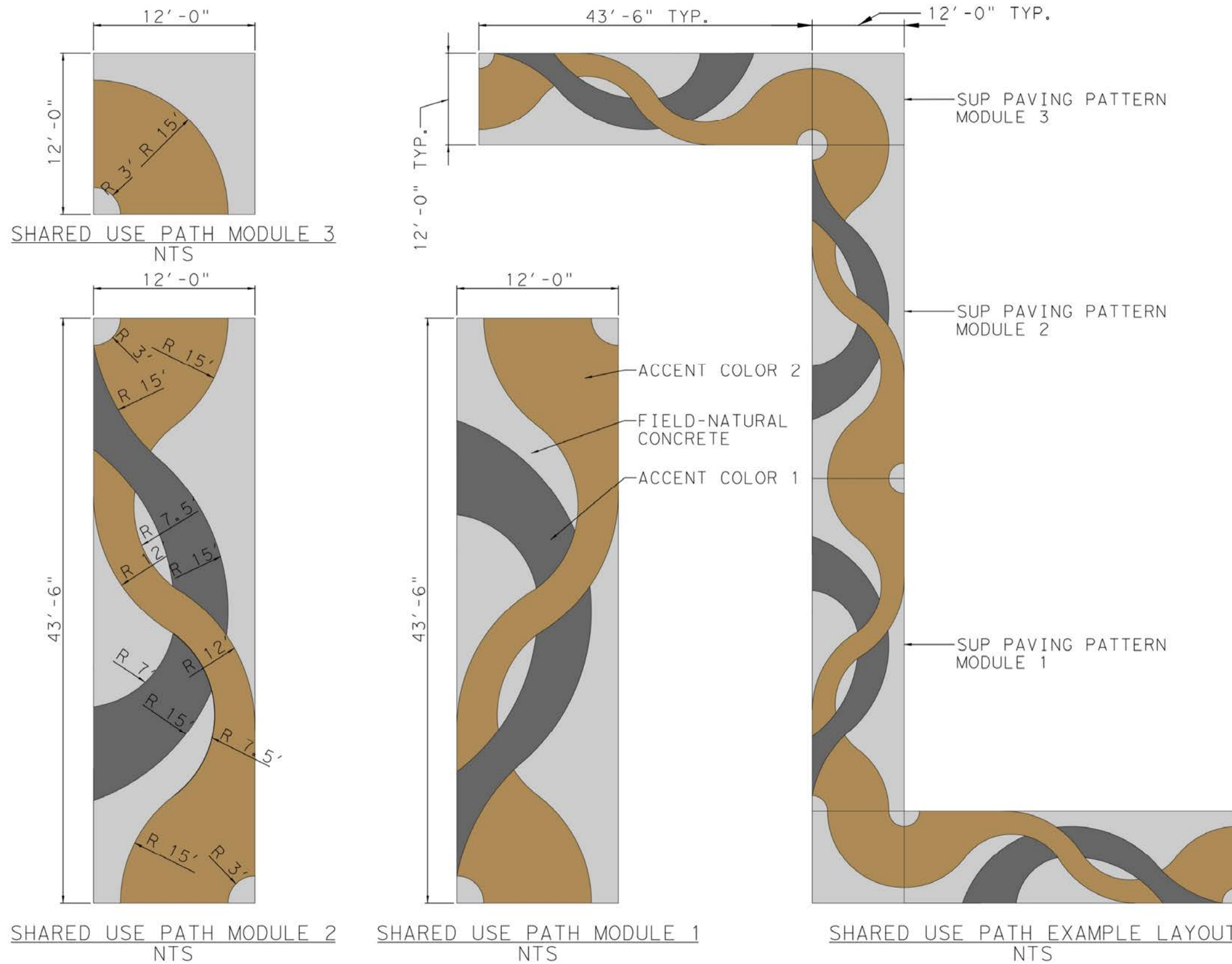

Notes

1. Alternate module 1 & 2 as required to create continuous pattern along SUP route
2. All SUP Special Pavement to be poured-in-place concrete using either
 - Integral color admixture or:
 - surface applied dry shake color hardener
4. All pavement to receive medium broom finish
5. See Color Matrix for pavement colors



SUP Overhead Art

SUP Overhead Art Notes

1. Art Panels to be fabricated of punched metal with internal supporting framework.
2. Panels are to be suspended by framework from bottom flange of bridge girders.
3. Each girder line shall have an art panel
4. Art work shall be comprised of a minimum of 3 unique shapes and shall be arranged to maximize random appearance as viewed along SUP.
5. Panels shall be sized and shaped to achieve pleasing composition within the area available for overhead art. See Elevation
6. LED robe lighting shall be enclosed within panels and provide internal lighting.
7. Mounting of art and electrical supply conduits shall be designed to accommodate bridge expansion, and vertical movement/ vibration.
8. Mounting of art to account for maximum sustained winds to be typical for the location.
9. Electrical supply conduits shall feed power from the top or bent cap end of the panel and shall not be readily visible.
10. Electrical supply conduits shall located along top of bent cap and enclosed within column and placed underground to power source.
11. Art panels to be fabricated in such manner that one side may be disassembled to provide access to maintain/replace internal lighting.
12. Refer to Design Guide Sections 2.1.1-2.1.2 for treatment of existing columns to remain.

SUP Overhead Art along Pond Springs Rd. Underpass

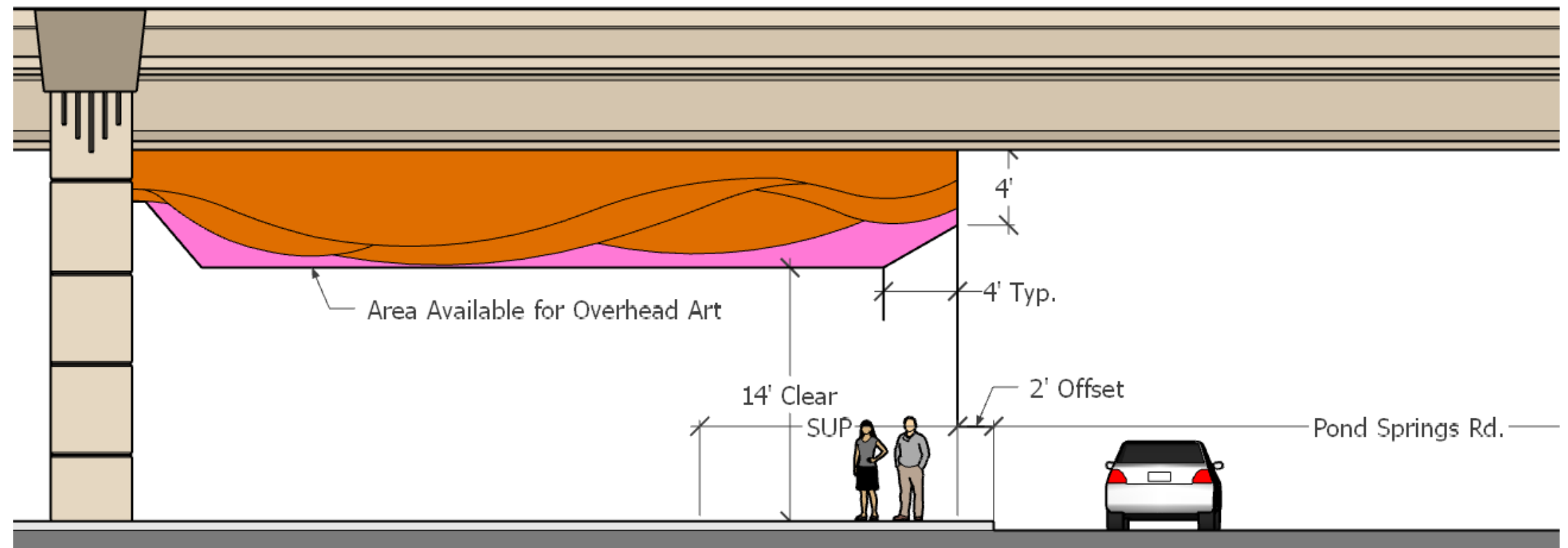

SUP Overhead Art - Elevation

Corridor Concept Landscape Plan

Corridor Concept Landscape Plans The Corridor Landscape Concept Plans identify the following:

- Areas of existing plantings to be preserved and protected
These areas are to be protected and preserved during the duration of the project and shall be restricted from all construction activities, storage, vehicle movements etc. per TP 10
- Specific locations of interchange plantings
The plant installation at the cross-street interchanges are to follow the concept design of plantings contained in this section
- Opportunity areas which are available for replacement plantings and potentially new plantings as prioritized in TP 10.
These areas have been identified as potential sites for placement of landscape plantings should the number of required plantings not fit within the plantings areas proximate to the cross-street interchange locations.

Overview

The intent of this Corridor Concept Landscape Plan is to provide direction for the placement of plant materials into the corridor at the completion of the other project improvements. To accomplish this, the DB contractor will conduct an inventory of existing plant materials as stipulated in TP 10. The purpose of the inventory is to quantify the numbers and types of plantings which at a minimum are to be restored to the corridor as a project requirement. Using the quantity of plant materials as determined through the inventory process, the DB contractor will prepare a landscape plan indicating the location of new plantings to restore the plantings in the corridor per the priority of locations as indicated in TP 10.

As determined through the plant inventory and the following ratios, the DB Contractor will provide plants for restoration of the corridor landscape.

1. Existing Shade Trees over 4" in dia. will be replaced with 2 (two) 2" cal. or #45 class container sized plants.
2. Existing Shade Trees 3" but less than 4" in diameter shall be replaced with 1 (one) 2" cal. or #25 class container sized plant.
3. Existing Shade Trees under 3" in diameter shall be restored at a minimum of 1-1/2" cal. or #20 class container sized plant.
4. Existing Ornamental Trees over 4" dia. will be replaced with 1 (one) 2" cal. or #45 class container sized plant
5. Existing Ornamental Trees under 4" dia. will be replaced with 1 (one) 2" cal. or #20 class container sized plant
6. Existing Shrubs over 4' in height shall be restored at a minimum size - #20 class container sized plant.
7. Existing Shrubs under 4' in height shall be restored at a minimum size - #15 class container sized plant.

General Plant Design and Layout Requirements

1. All shrub plantings are to be installed in mass and contained within a mulch bed which is further contained by a planter, curb, landscape curb or mow strip.
2. To the greatest extent possible, landscape planters shall be used at all cross-street interchange locations as indicated in this section.
3. The dimensions of the interchange planters are to be adjusted to fit the available space within each interchange per general guidance of this section
4. The number of trees located outside the planters shall be a minimum of 3 per location but desired to be 5-7 per location as space permits.
5. The priority for placement of replacement plantings is indicated in TP 10.
6. Plant selection shall be from the Landscape Plant Palette located in this section.

Clearing / Grubbing and Preservation of Existing Plantings

1. All existing plantings located between the back curb along the service drive and the Main Lanes shall be removed unless otherwise noted on the corridor landscape plans.
2. Plantings to be preserved shall be protected with perimeter fencing as indicated in TP 10.
3. In select areas, See sheet plantings which must be removed due to construction within areas of preservation, shall be replanted proximate to the area of removal as space permits and at the ratios as stipulated above. In the event the remaining space is inadequate to relocate plantings, they may be located within an adjacent opportunity planting area identified on the plans.
4. In the event that select areas of vegetation slated to be preserved shall prevent the efficient construction of the project, the DB contractor shall identify the reason for, and quantify the area of disturbance on a scaled plan sheet(s) for RMA for review and approval. Upon approval, the tree inventory, and landscape design plans submittals shall include the new areas of disturbance and replacement plantings at the project requirement rates as stated above.



Far West Boulevard Landscape Opportunity Areas

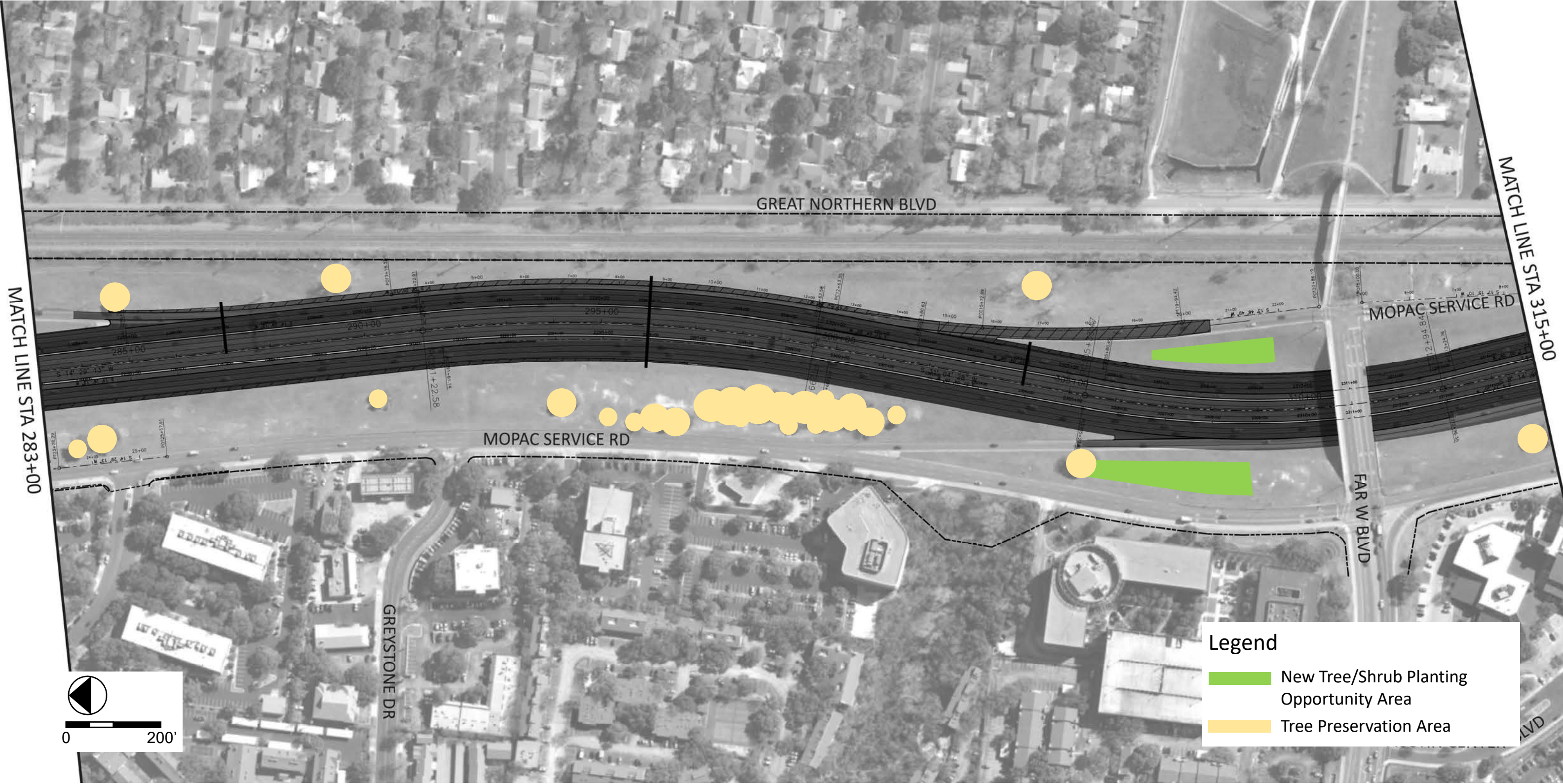

Legend

- New Tree/Shrub Planting Opportunity Area
- Tree Preservation Area

W Anderson Lane & Spicewood Springs Road Landscape Opportunity Areas

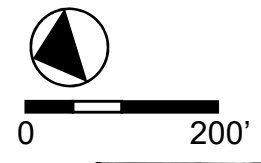



Steck Avenue Landscape Opportunity Areas



N Mopac Expressway Landscape Opportunity Areas

Legend

-  New Tree/Shrub Planting Opportunity Area
-  Tree Preservation Area

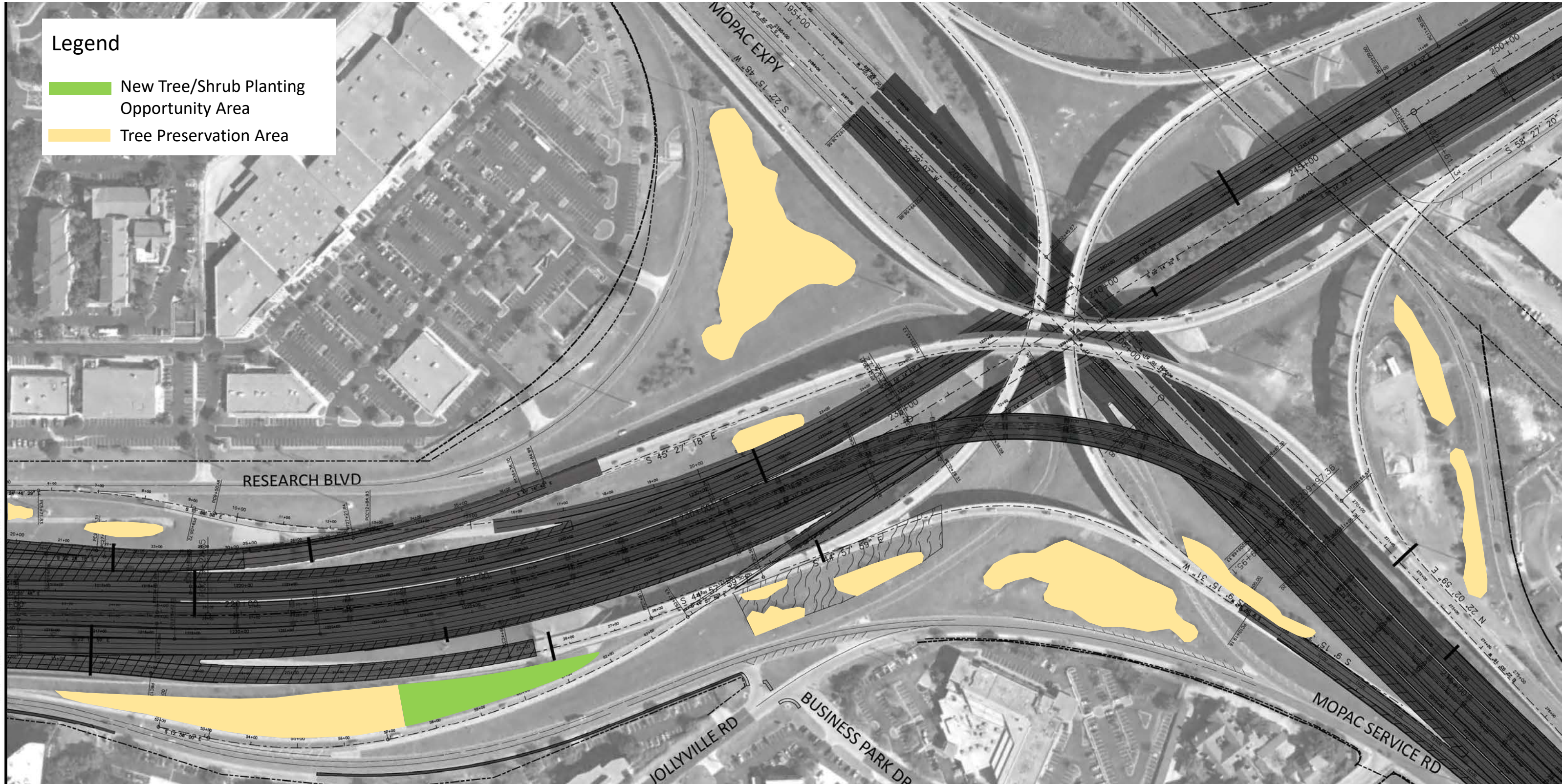

MATCH LINE STA 215+00

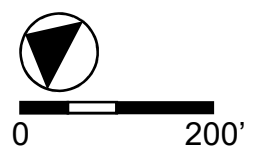

N Capital of Texas Highway Landscape Opportunity Areas

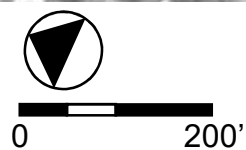
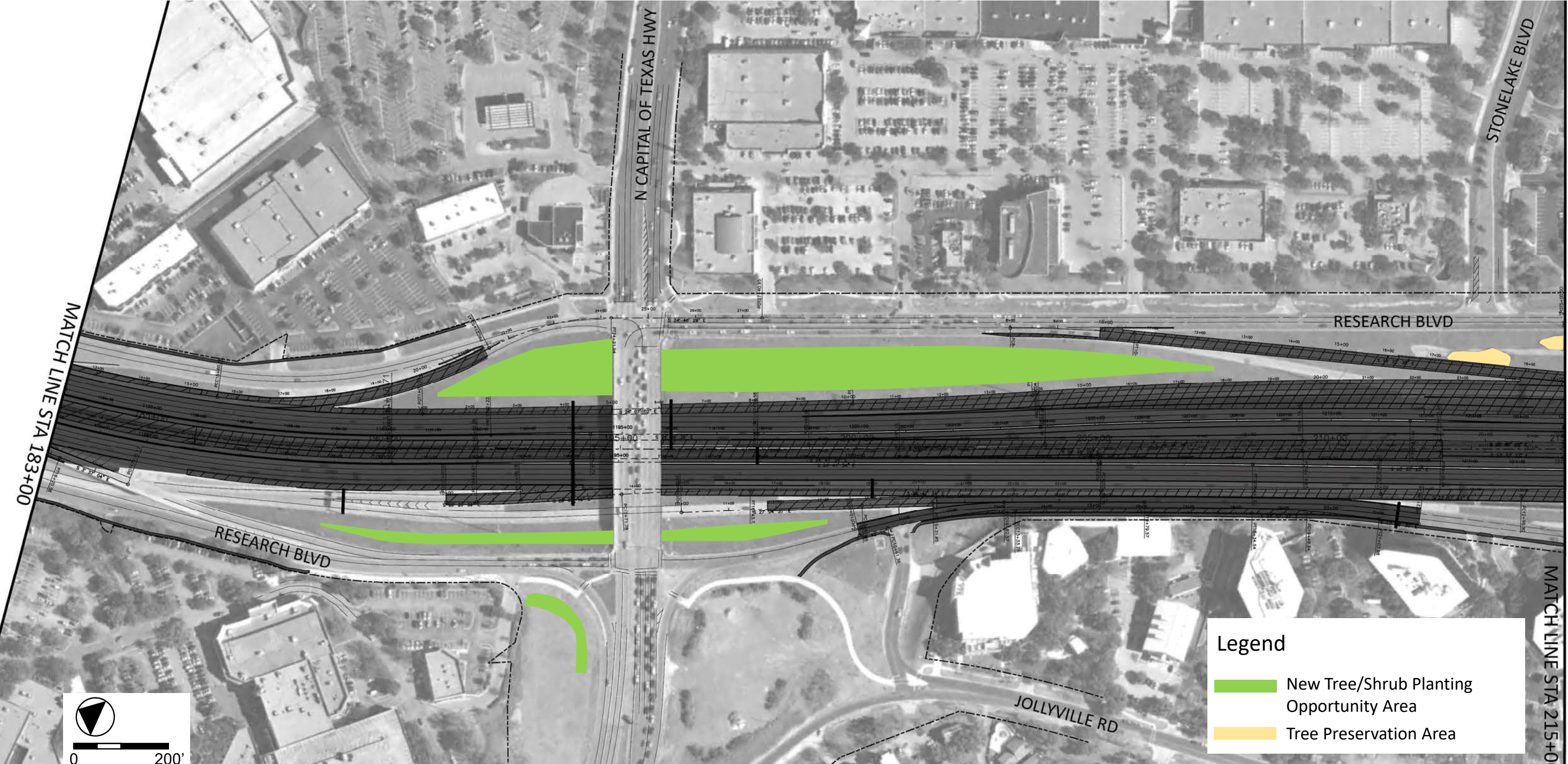

Legend

- New Tree/Shrub Planting Opportunity Area
- Tree Preservation Area

West Braker Lane & Great Hills Trail Landscape Opportunity Areas



Legend

- New Raised Planters - See Detail
- New Tree/Shrub Planting Opportunity Area
- Tree Preservation Area

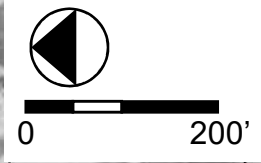

Balcones Woods Boulevard Landscape Opportunity Areas

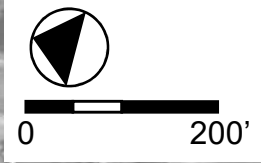
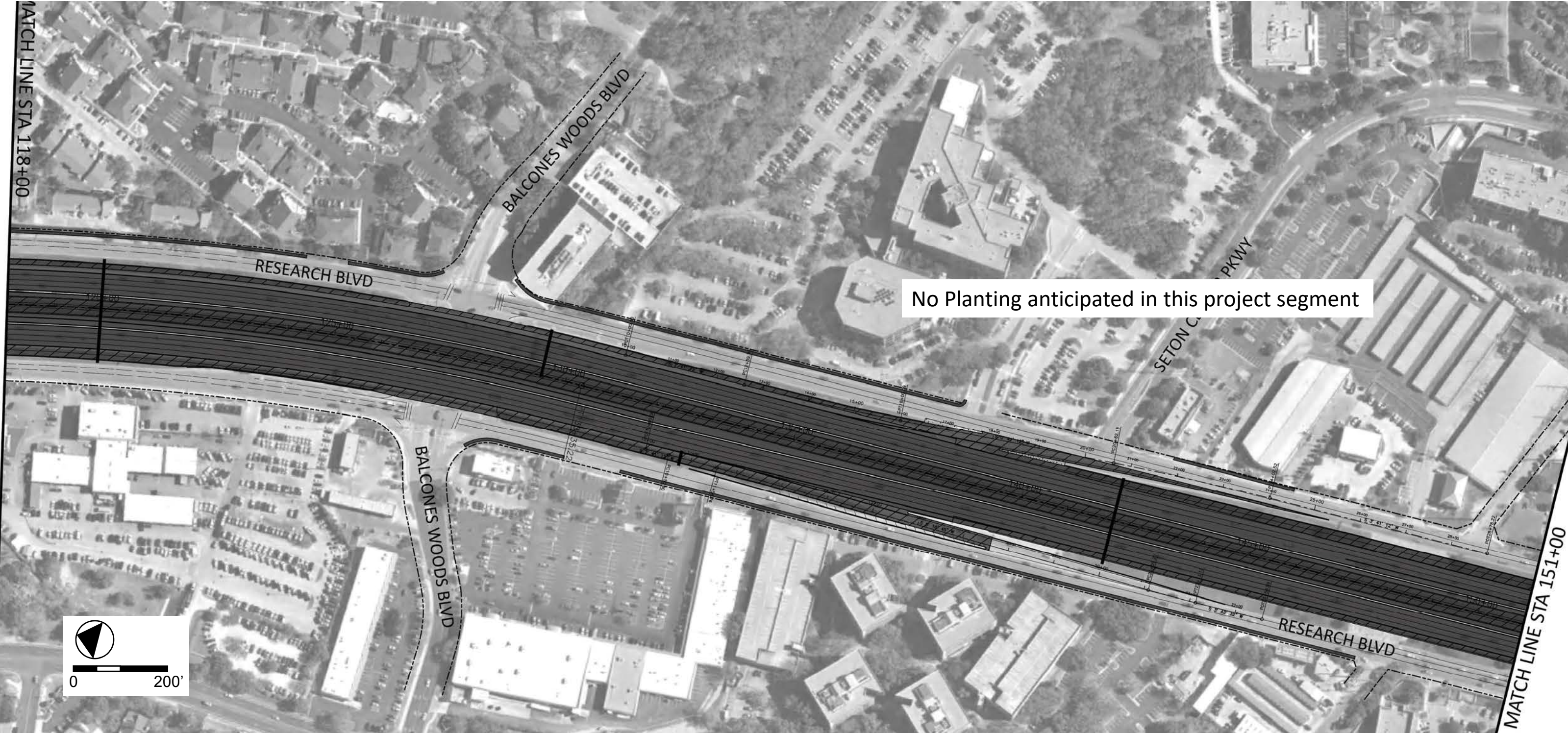

Duval Road Landscape Opportunity Areas

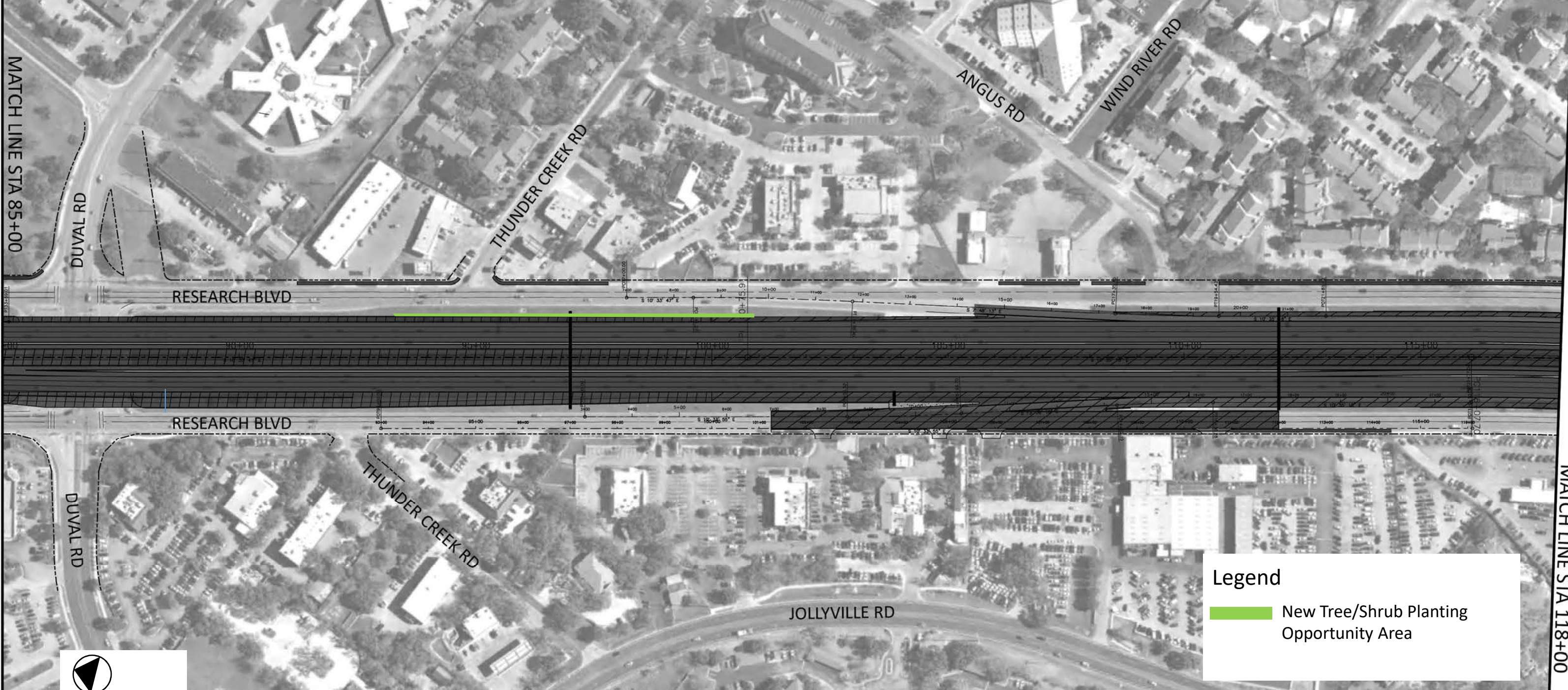

Legend

New Tree/Shrub Planting Opportunity Area

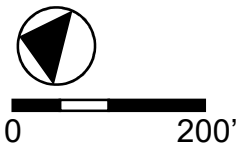

Duval Road Landscape Opportunity Areas

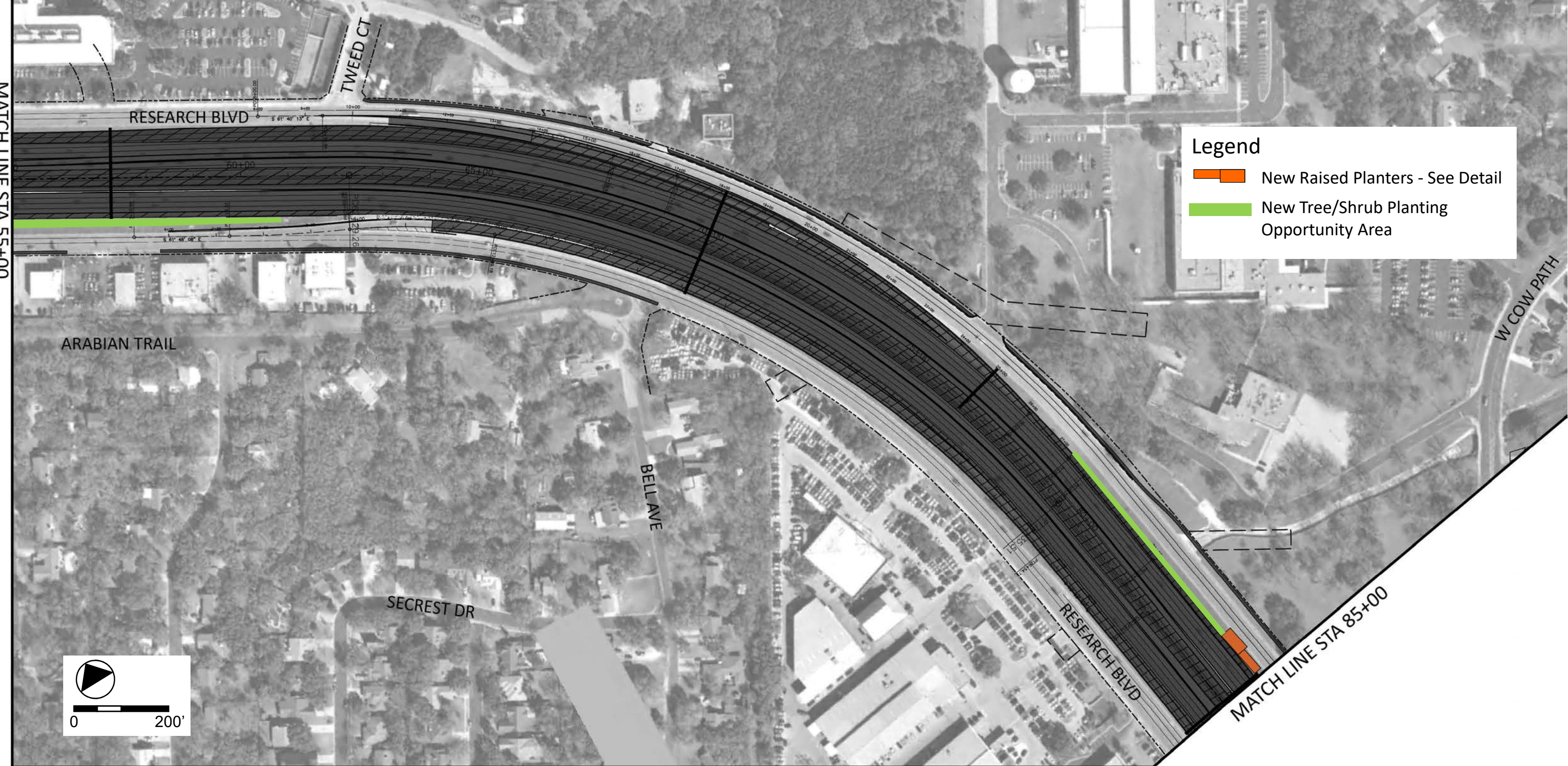

Oak Knoll Road Landscape Opportunity Areas





McNeil Drive Landscape Opportunity Areas



Pond Springs Rd. Road Landscape Opportunity Areas

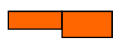

Legend

-  New Raised Planters - See Detail
-  New Tree/Shrub Planting Opportunity Area

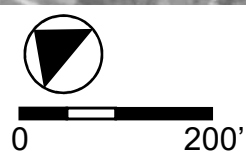

Hunters Chase Drive Landscape Opportunity Areas



Legend

 New Tree/Shrub Planting Opportunity Area

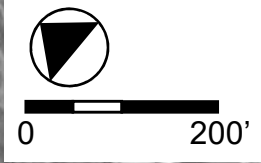

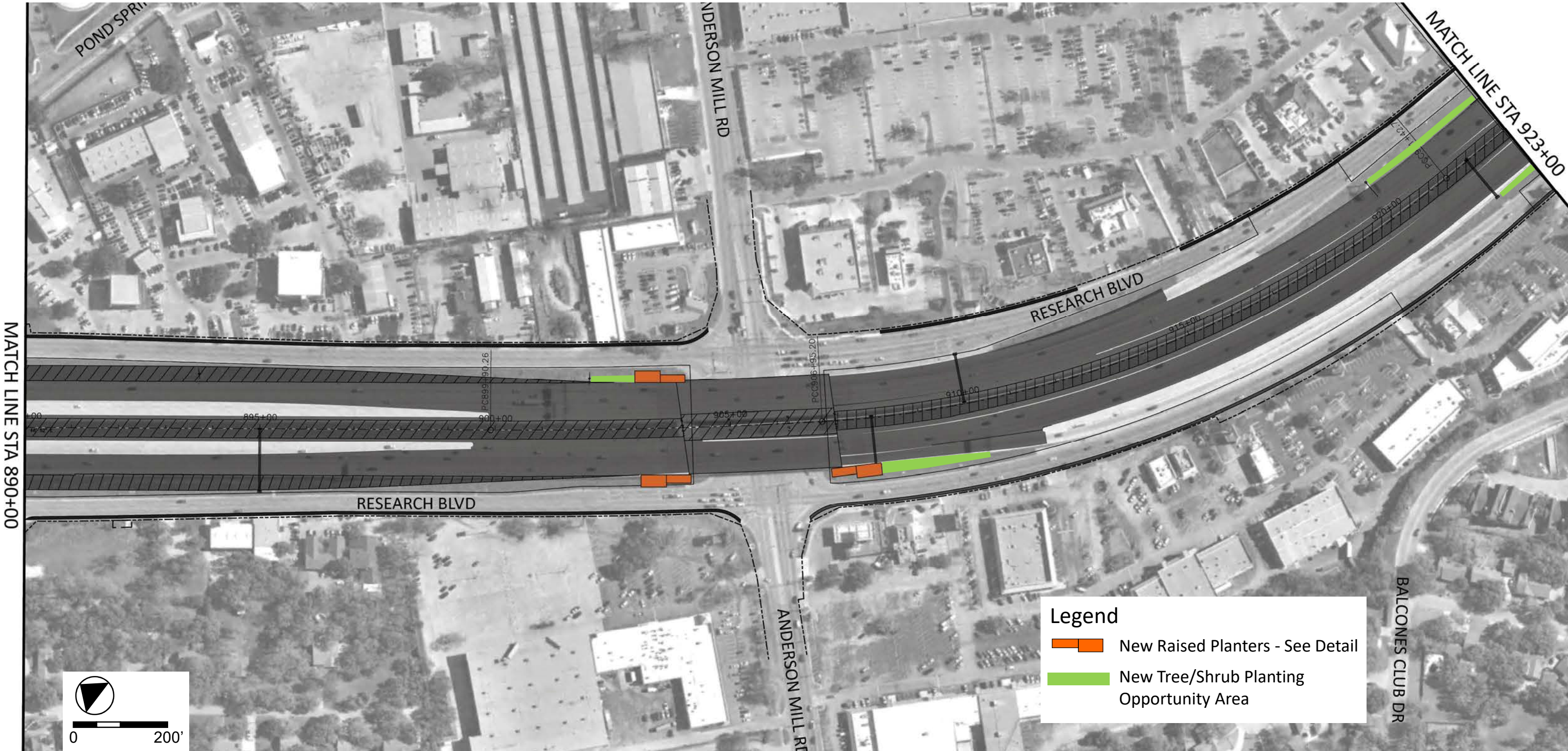

Anderson Mill Road Landscape Opportunity Areas

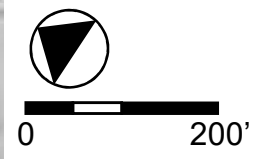
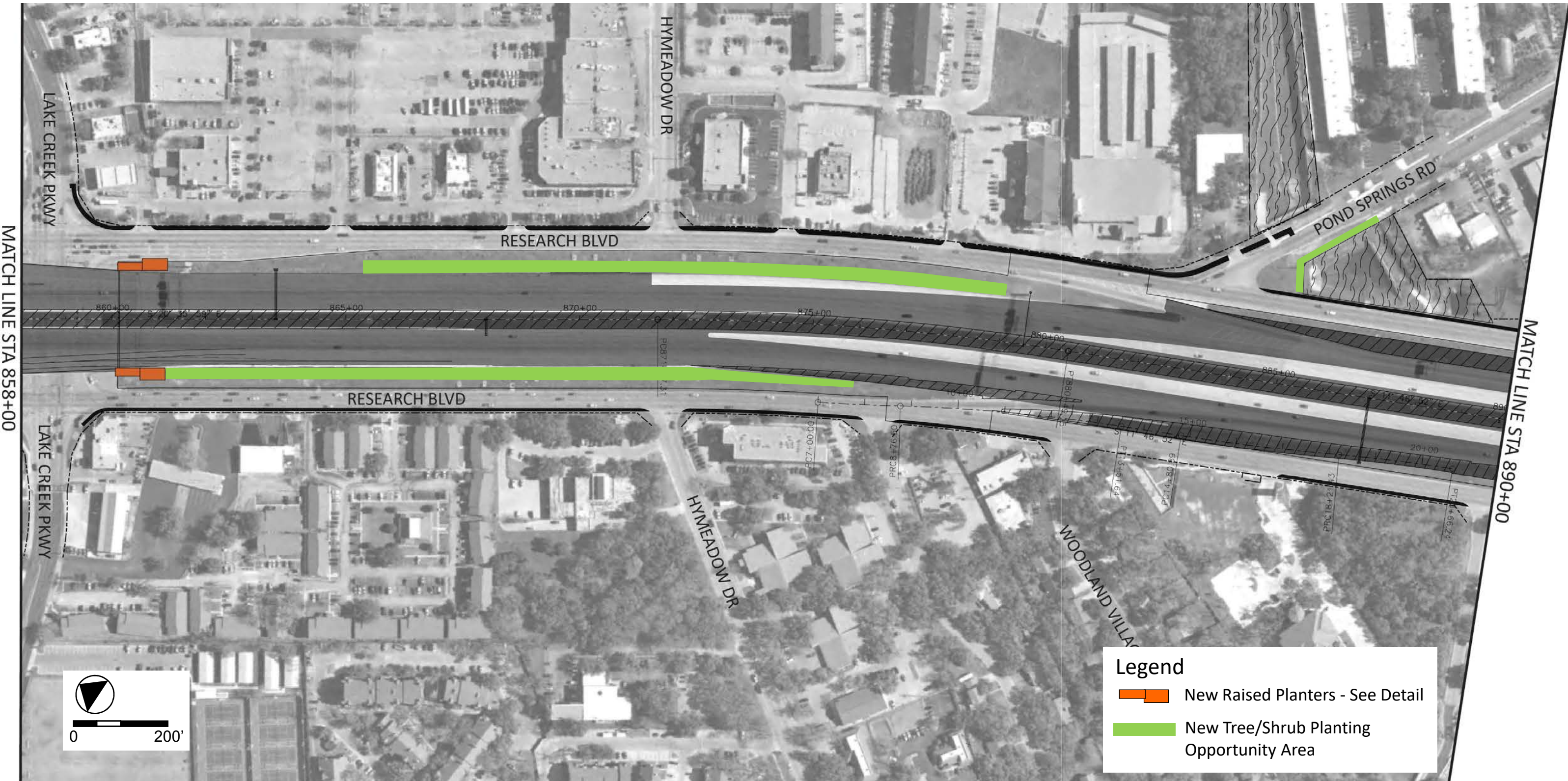

Lake Creek Parkway Landscape Opportunity Areas



Legend

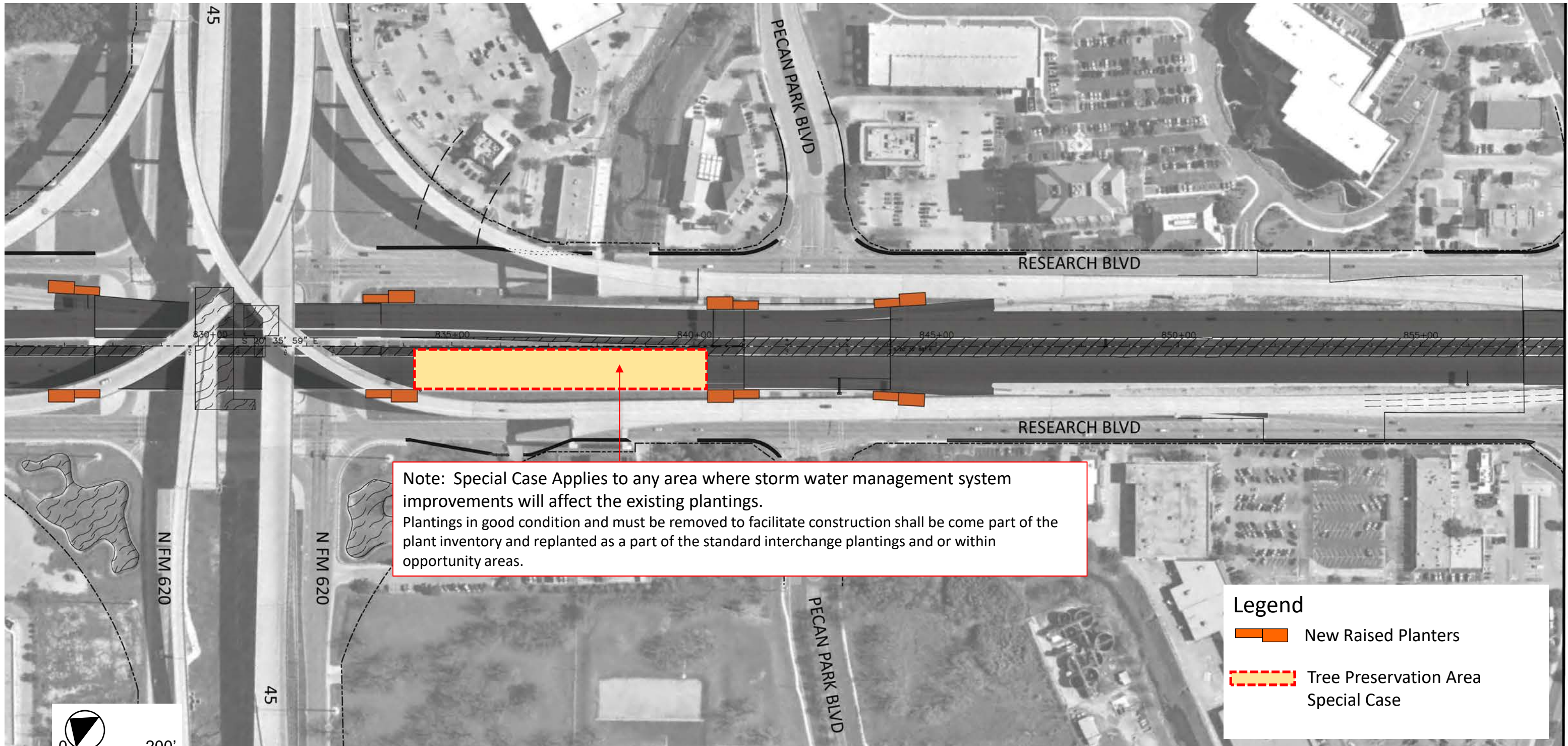

-  New Raised Planters - See Detail
-  New Tree/Shrub Planting Opportunity Area

North FM 620 Landscape Opportunity Areas



Note: Special Case Applies to any area where storm water management system improvements will affect the existing plantings. Plantings in good condition and must be removed to facilitate construction shall be come part of the plant inventory and replanted as a part of the standard interchange plantings and or within opportunity areas.

Legend

-  New Raised Planters
-  Tree Preservation Area Special Case

Typical – Concept Landscape Opportunity Area



Main Lanes

Landscape Opportunity Area –

- **Mass Planting Landscape Buffer**
- **Width of planting areas varies depending upon location**

**On/Off Ramp /
Service Drive**

183 North Mobility Project Typical Planter Perspective



View of Typical Planter development and Replacement Tree and Shrub Planting beyond. See Landscape Opportunity Areas Plans for Planter locations and available planting area for Replacement Trees and Shrubs. See Typical Planter Sizes page and see Planter Schedule for additional planter information.

183 North Mobility Project Typical Planter Plan

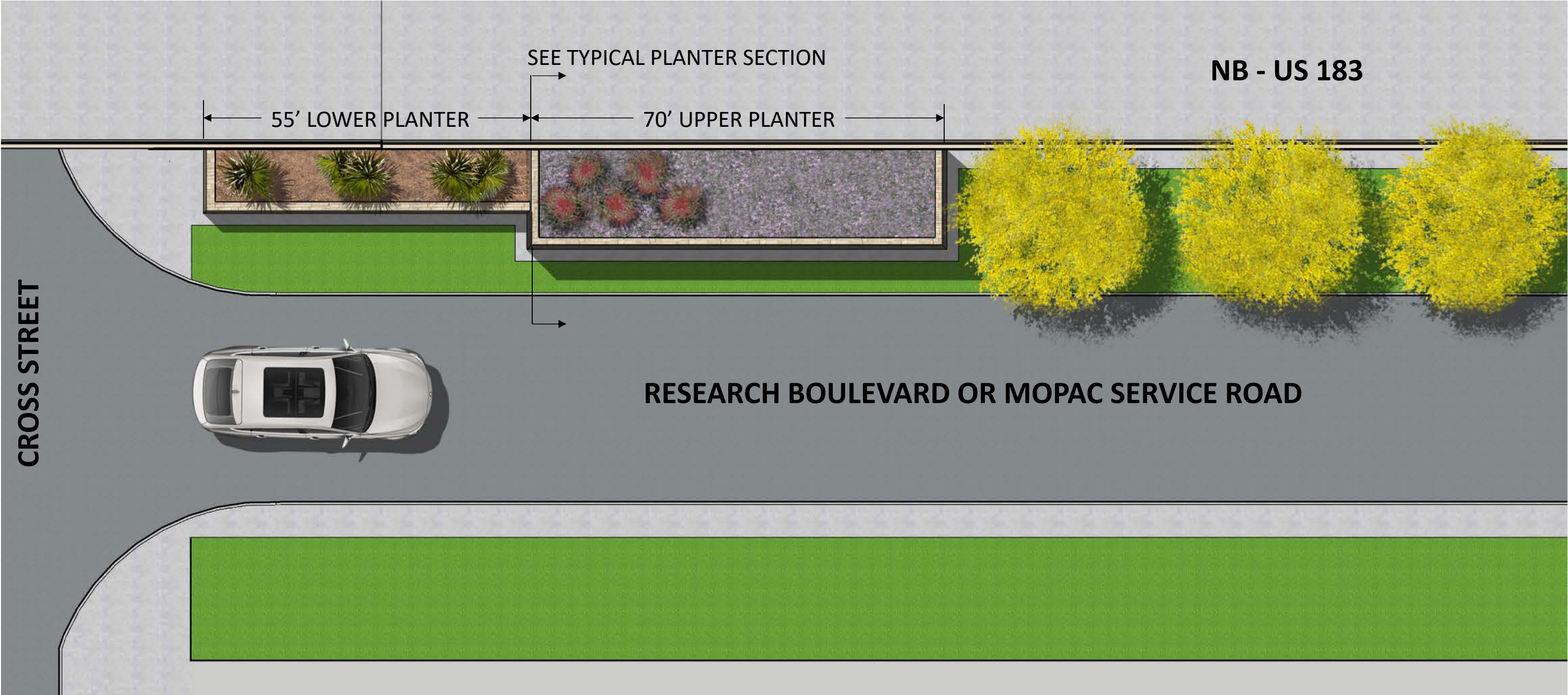

Typical Planter length dimensions are shown. Planter widths vary with each intersection location, 3 sizes in project. See Typical Planter Sizes page and see Planter Schedule.

183 North Mobility Project Typical Cross-Street Intersection Planter Sizes

Planter Plant Schedule:

Spanish Dagger (*Yucca gloriosa*), #30 container



Purple Trailing Lantana (*Lantana montevidensis*), #5 container



Red Yucca (*Hesperaloe parviflora*), #30 container

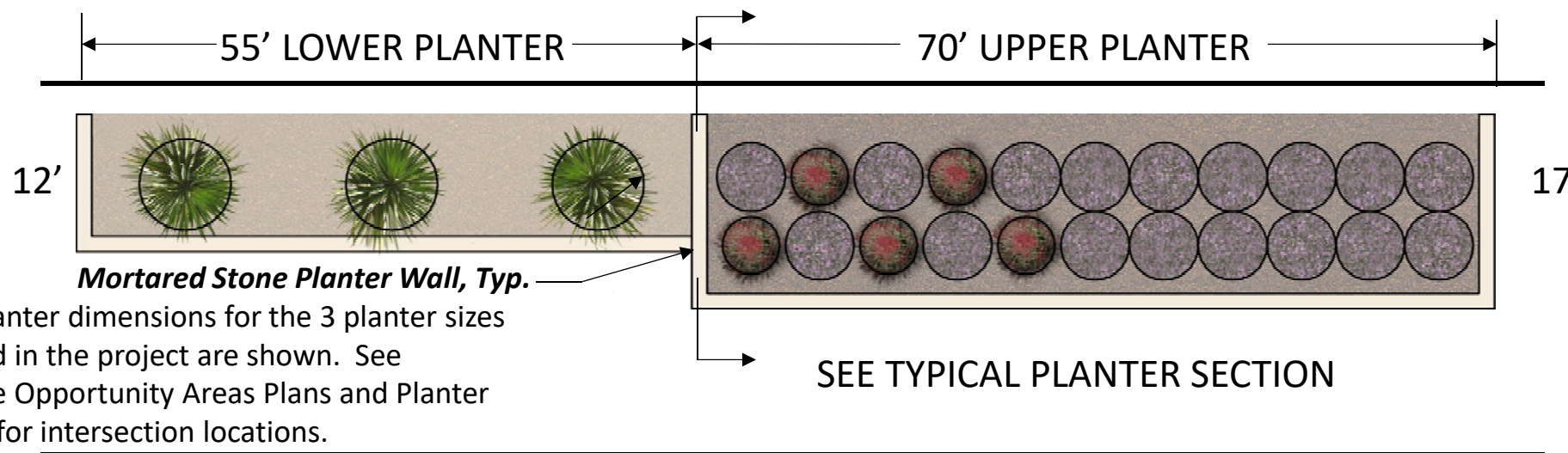

Note:

- Typical Planter dimensions for the 3 planter sizes to be used in the project are shown. See Landscape Opportunity Areas Plans and Planter Schedule for intersection locations.

CROSS STREET SIDE

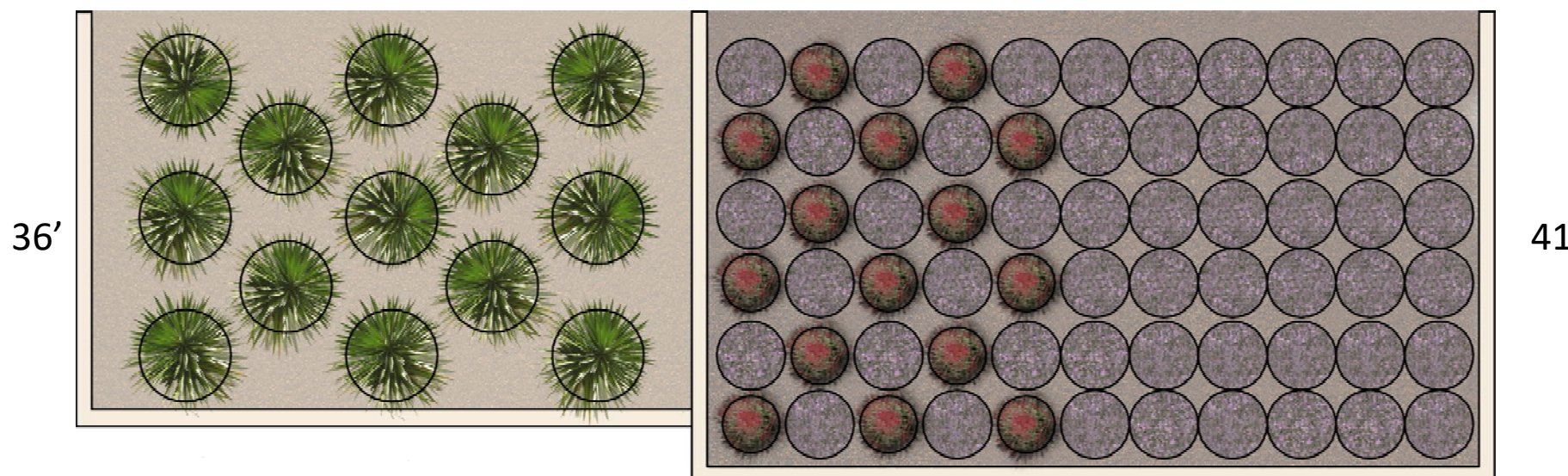
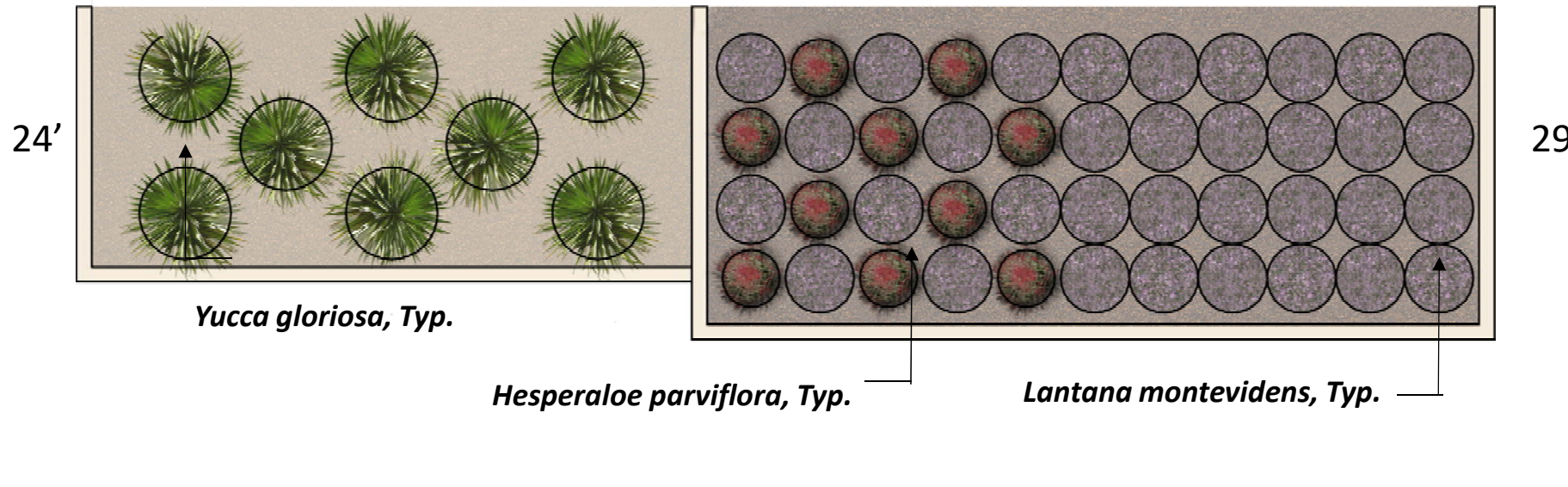

183 North Mobility Project Typical Section Thru Planter

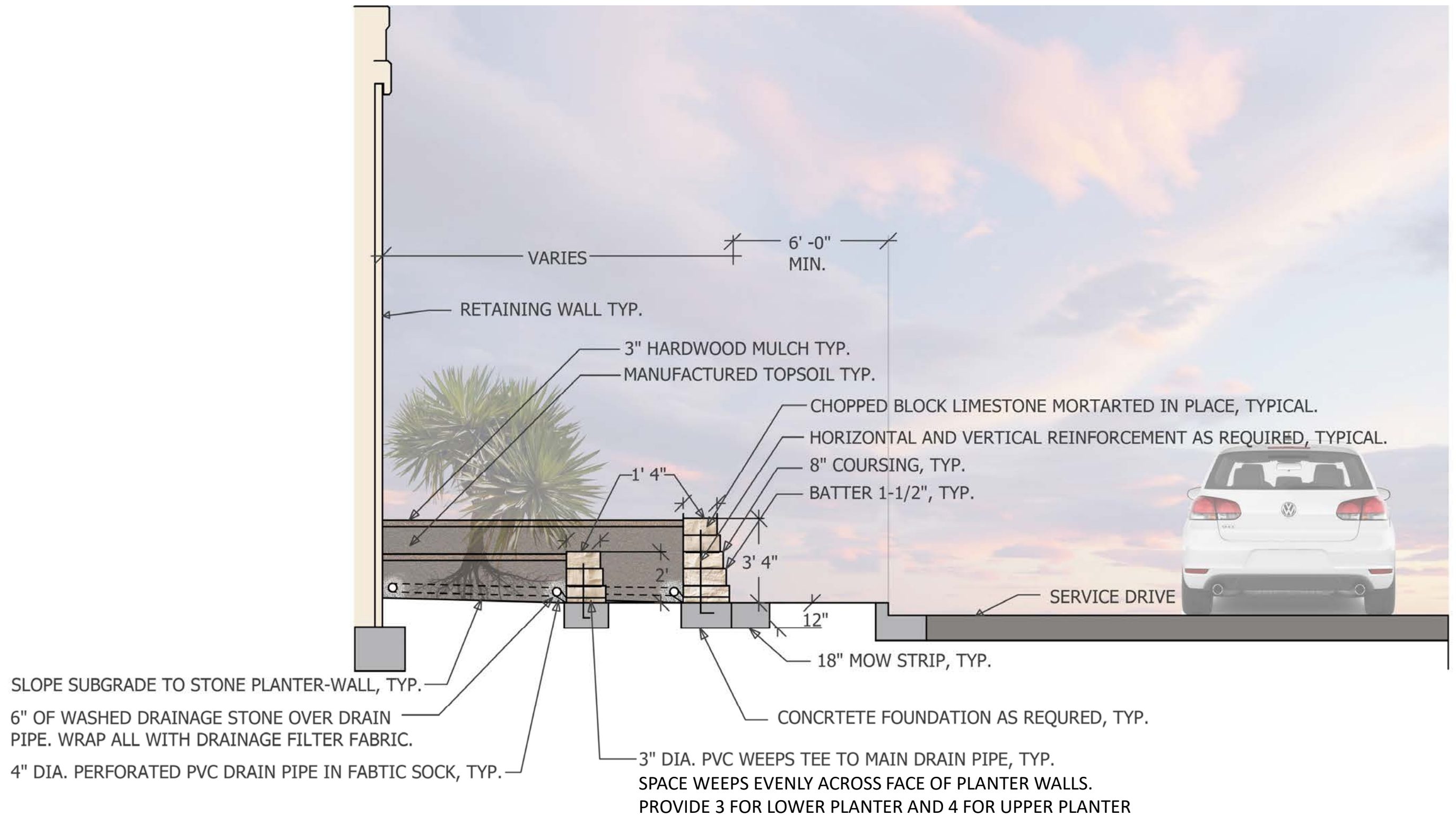

Typical Planter Section shows section through lower planter and section through upper planter combined. Bottom of planter is to slope toward face of stone planter walls and drain toward perimeter drain pipe and weep holes. Pipe extends through weep holes and is cut 2 inches from outer face of wall. Stone is cut and mortared tight around weep hole pipes. Provide positive drainage away from planters and from planter weep inverts to top of roadway curb.

183 North Mobility Project Cross-Street Intersection Planter Schedule

INTERSECTION US 183+A3:G27 AT 620/45 SOUTH

	CURB TO WALL WIDTH	LENGTH CURB-OBJ	FLYOVER HEIGHT	LOWER PLANTER LENGTH	LOWER PLANTER WIDTH	UPPER PLANTER LENGTH	UPPER PLANTER WIDTH	SPLIT PLANTERS Y/N
NW QUADRANT	43 ft	21 ft		55 ft	24 ft	70 ft	29 ft	Y
NE QUADRANT	37 ft			55 ft	24 ft	70 ft	29 ft	N
SW QUADRANT	52 ft	50 ft	50 ft	55 ft	36 ft	70 ft	41 ft	Y
SE QUADRANT	62 ft	75 ft	75 ft	55 ft	36 ft	70 ft	41 ft	N

INTERSECTION US 183 AT PECAN PARK BLVD

	CURB TO WALL WIDTH	LENGTH CURB-OBJ	FLYOVER HEIGHT	LOWER PLANTER LENGTH	LOWER PLANTER WIDTH	UPPER PLANTER LENGTH	UPPER PLANTER WIDTH	SPLIT PLANTERS Y/N
NW QUADRANT	65 ft	25 ft	40 ft	55 ft	36 ft	70 ft	41 ft	Y
NE QUADRANT	35 ft	50 ft	40 ft	55 ft	24 ft	70 ft	29 ft	N
SW QUADRANT	38 ft	38 ft	60 ft	55 ft	24 ft	70 ft	29 ft	N
SE QUADRANT	56 ft	50 ft	60 ft	55 ft	36 ft	70 ft	41 ft	N

INTERSECTION US 183 AT LAKE CREEK PKWY

	CURB TO WALL WIDTH	LENGTH CURB-OBJ	FLYOVER HEIGHT	LOWER PLANTER LENGTH	LOWER PLANTER WIDTH	UPPER PLANTER LENGTH	UPPER PLANTER WIDTH	SPLIT PLANTERS Y/N
NW QUADRANT	70 ft	25 ft	12 ft	x	x	x	x	Y
NE QUADRANT	23 ft			55 ft	12 ft	70 ft	17 ft	N
SW QUADRANT	60 ft	10 ft	12 ft	x	x	x	x	Y
SE QUADRANT	43 ft			55 ft	24 ft	70 ft	29 ft	N

INTERSECTION US 183 AT ANDERSON MILL RD

	CURB TO WALL WIDTH	LENGTH CURB-OBJ	FLYOVER HEIGHT	LOWER PLANTER LENGTH	LOWER PLANTER WIDTH	UPPER PLANTER LENGTH	UPPER PLANTER WIDTH	SPLIT PLANTERS Y/N
NW QUADRANT	35 ft			55 ft	24 ft	70 ft	29 ft	N
NE QUADRANT	0 ft			x	x	x	x	N
SW QUADRANT	24 ft			55 ft	12 ft	70 ft	17 ft	N
SE QUADRANT	36 ft			55 ft	24 ft	70 ft	29 ft	N

INTERSECTION US 183 AT POND SPRINGS RD AND MCNEIL DR

	CURB TO WALL WIDTH	LENGTH CURB-OBJ	FLYOVER HEIGHT	LOWER PLANTER LENGTH	LOWER PLANTER WIDTH	UPPER PLANTER LENGTH	UPPER PLANTER WIDTH	SPLIT PLANTERS Y/N
NW QUADRANT	33 ft			55 ft	24 ft	70 ft	29 ft	N
NE QUADRANT	25 ft			55 ft	12 ft	70 ft	17 ft	N
SW QUADRANT	6 ft			x	x	x	x	N
SE QUADRANT	18 ft			x	x	x	x	N

INTERSECTION US 183 AT OAK KNOLL RD

	CURB TO WALL WIDTH	LENGTH CURB-OBJ	FLYOVER HEIGHT	LOWER PLANTER LENGTH	LOWER PLANTER WIDTH	UPPER PLANTER LENGTH	UPPER PLANTER WIDTH	SPLIT PLANTERS Y/N
NW QUADRANT	16 ft			x	x	x	x	N
NE QUADRANT	9 ft			x	x	x	x	N
SW QUADRANT	6 ft			x	x	x	x	N
SE QUADRANT	18 ft			x	x	x	x	N

INTERSECTION US 183 AT DUVAL RD

	CURB TO WALL WIDTH	LENGTH CURB-OBJ	FLYOVER HEIGHT	LOWER PLANTER LENGTH	LOWER PLANTER WIDTH	UPPER PLANTER LENGTH	UPPER PLANTER WIDTH	SPLIT PLANTERS Y/N
NW QUADRANT	26 ft			55 ft	12 ft	70 ft	17 ft	N
NE QUADRANT	14 ft			x	x	x	x	N
SW QUADRANT	4 ft			x	x	x	x	N
SE QUADRANT	8 ft			x	x	x	x	N

Notes:

The tables above and on the next page indicate:

- approximate width and length of clear ground for planter installations,
- distance from cross-street curb or sidewalk to an object or obstruction such as a flyover lane column or utility structure,
- proposed planter size to install against retaining walls at each interchange quadrant,
- and indication if planters may need to be separated or modified to leave space around an obstruction or to provide maintenance access to a sign or utility structure.
- planter placement will accommodate existing paved drainage structures

183 North Mobility Project Cross-Street Intersection Planter Schedule

**INTERSECTION US 183 AT BALCONES
WOODS BLVD**

	CURB TO WALL WIDTH	LENGTH CURB-OBJ	FLYOVER HEIGHT	LOWER PLANTER LENGTH	LOWER PLANTER WIDTH	UPPER PLANTER LENGTH	UPPER PLANTER WIDTH	SPLIT PLANTERS Y/N
NW QUADRANT	15 ft			x	x	x	x	N
NE QUADRANT	3 ft			x	x	x	x	N
SW QUADRANT	2 ft			x	x	x	x	N
SE QUADRANT	8 ft			x	x	x	x	N

**INTERSECTION US 183 AT W BRAKER
LN**

	CURB TO WALL WIDTH	LENGTH CURB-OBJ	FLYOVER HEIGHT	LOWER PLANTER LENGTH	LOWER PLANTER WIDTH	UPPER PLANTER LENGTH	UPPER PLANTER WIDTH	SPLIT PLANTERS Y/N
NW QUADRANT	15 ft			x	x	x	x	N
NE QUADRANT	0 ft			x	x	x	x	N
SW QUADRANT	4 ft			x	x	x	x	N
SE QUADRANT	30 ft			55 ft	12 ft	70 ft	17 ft	N

**INTERSECTION US 183 AT GREAT
HILLS TRAIL**

	CURB TO WALL WIDTH	LENGTH CURB-OBJ	FLYOVER HEIGHT	LOWER PLANTER LENGTH	LOWER PLANTER WIDTH	UPPER PLANTER LENGTH	UPPER PLANTER WIDTH	SPLIT PLANTERS Y/N
NW QUADRANT	47 ft			55 ft	36 ft	70 ft	41 ft	N
NE QUADRANT	7 ft			x	x	x	x	N
SW QUADRANT	7 ft			x	x	x	x	N
SE QUADRANT	17 ft			x	x	x	x	N

Notes:

The tables above indicate:

- approximate width and length of clear ground for planter installations,
- distance from cross-street curb or sidewalk to an object or obstruction such as a flyover lane column or utility structure,
- proposed planter size to install against retaining walls at each interchange quadrant,
- and indication if planters may need to be separated or modified to leave space around an obstruction or to provide maintenance access to a sign or utility structure.
- planter placement will accommodate existing paved drainage structures

183 North Mobility Project Landscape Plant Palette

The planting design shall draw from the plants identified from these lists. Alternative plant species will only be considered after review and approval of the CTRMA. The Planters also incorporate Lantana as a groundcover, which is not included on these lists.

(Small Shrubs- 1'-6' Ht.)

Scientific Name	Common Name
<i>Anisacanthus quadrifidus var wrightii</i>	Flame acanthus
<i>Hesperaloe parviflora</i>	Red Yucca
<i>Mahonia trifoliolata</i>	Agarita
<i>Pavonia lasiopetala</i>	Rock rose
<i>Sabal minor</i>	Dwarf palmetto
<i>Salvia greggii</i>	Cherry sage
<i>Tecoma stans</i>	Yellow bells

(Large Shrubs - 6'-12' Ht.)

Scientific Name	Common Name
<i>Eysenhardtia texana</i>	Kidneywood
<i>Ilex decidua</i>	Possumhaw holly
<i>Leucophyllum frutescens</i>	Texas ranger
<i>Rhus aromatica</i>	Aromatic sumac
<i>Rhus virens</i>	Evergreen sumac
<i>Yucca gloriosa</i>	Spanish dagger

183 North Mobility Project Landscape Plant Palette

(Understory Trees - 8'-35' Ht.)

Scientific Name	Common Name
<i>Caesalpinia pulcherrima</i>	Pride of Barbados
<i>Cercis canadensis var. texensis</i>	Texas redbud
<i>Chilopsis linearis</i>	Desert willow
<i>Cornus drummondii</i>	Roughleaf dogwood
<i>Diospyros texana</i>	Texas persimmon
<i>Ilex vomitoria</i>	Yaupon holly
<i>Leucaena retusa</i>	Goldenball leadtree
<i>Parkinsonia aculeata</i>	Retama
<i>Prunus mexicana</i>	Mexican plum
<i>Rhus lanceolata</i>	Flameleaf sumac
<i>Sapindus drummondii</i>	Western soapberry
<i>Sophora affinis</i>	Eve's necklace
<i>Sophora secundiflora</i>	Texas mountain laurel
<i>Ungadia speciosa</i>	Mexican buckeye
<i>Viburnum prunifolium</i>	Blackhaw viburnum

(Shade Trees - 40' + Ht.)

Scientific Name	Common Name
<i>Pistacia texana</i>	Texas pistache
<i>Platanus mexicana</i>	Mexican sycamore
<i>Prunus serotina var. eximia</i>	Escarpment cherry
<i>Quercus buckleyi</i>	Texas red oak
<i>Quercus macrocarpa</i>	Bur oak
<i>Quercus muehlenbergii</i>	Chinquapin oak
<i>Quercus polymorpha</i>	Monterrey oak
<i>Quercus sinuata</i>	Durland oak
<i>Quercus virginiana</i>	Live oak
<i>Taxodium mucronatum</i>	Montezuma cypress
<i>Ulmus crassifolia</i>	Cedar elm

Central Texas Regional Mobility Authority
Technical Provisions
For
183 North Mobility Project

ATTACHMENT 11-1
DESIGN CRITERIA SUMMARY

Criteria	EXPRESS LANES AND GENERAL PURPOSE LANES	RAMPS	DIRECT CONNECTORS (DC)	COLLECTOR-DISTRIBUTOR (C-D)	TURNAROUNDS	FRONTAGE ROADS	REFERENCE
Functional Classification	Urban Freeway	Urban Freeway	Urban Freeway	Urban Arterial	Turn-Around	Urban Arterial	Per Schematic Plan
Design Speed [mph]	60	40	40	40	15	40	Per Schematic Plan
Number of Through Lanes (per direction)							See <i>Exhibit D – Item 3.7.1 – Schematic Plans</i>
Stopping Sight Distance [ft]	570	305	305	305	80	305	TxDOT RDM (2018) Table 2-1
Horizontal Alignment							
Min. Radius [ft] with Superelevation	2,195 (usual) 1,330 (absolute)	610 (usual) 485 (absolute)	610 (usual) 485 (absolute)	610 (usual) 485 (absolute)	-	533	TxDOT RDM (2018) Table 2-3, Table 2-6, Table 2-5 (for frontage roads)
Min Radius [ft] without Superelevation	11,100	5,230	5,230	5,230	-	762	TxDOT RDM (2018) Table 2-4, Table 2-5 (for frontage roads)
Max. Superelevation Rate [%]	6	6	6	6	4	4	TxDOT RDM (2018) Table 2-6, Table 2-5 (for frontage roads)
Max Relative Gradient for Superelevation Transition [%]	0.45	0.58	0.58	0.58	0.78	0.58	TxDOT RDM (2018) Table 2-8
Vertical Alignment							
Max. Profile Grade [%]	4 ¹	4 ²	5 ³	6	-	7	TxDOT RDM (2018) Table 2-11
Min. Profile Grade [%]	See TxDOT RDM (2018) bottom of page 2-27 and top of page 2-28 for minimum based on drainage. Minimums shown at <i>Exhibit D – Item 3.7.1 – Schematic Plans</i> can be used as used						TxDOT RDM (2018) Pages 2-27, 2-28 Per Schematic Plan
Min. Length of Vertical Curve (L=3V _D) [ft]	180	120	120	120	45	120	TxDOT RDM (2018) Page 2-29
Min. K-Value for Crest Curve	151	44	44	44	3	44	TxDOT RDM (2018) Figure 2-5
Min. K-Value for Sag Curve	136	64 ⁴	64	64	10	64	TxDOT RDM (2018) Figure 2-6 ⁴
Vertical Clearance							
Over Roadway [ft]	16.5 ⁵						TxDOT RDM (2018) Table 3-1 & Page 3-63
Over Roadway and under Overhead Signs [ft]	17.5						TxDOT Freeway Signing Handbook (2008) Page 2-13

Criteria	EXPRESS LANES AND GENERAL PURPOSE LANES	RAMPS	DIRECT CONNECTORS (DC)	COLLECTOR-DISTRIBUTOR (C-D)	TURNAROUNDS	FRONTAGE ROADS	REFERENCE
Functional Classification	Urban Freeway	Urban Freeway	Urban Freeway	Urban Arterial	Turn-Around	Urban Arterial	Per Schematic Plan
Design Speed [mph]	60	40	40	40	15	40	Per Schematic Plan
Roadway Features							
Min. Lane Width [ft]	12 ⁶	14 (1-lane) 12 (2-lane)	14 (1-lane) 12 (2-lane)	12	.7	11 ⁸	TxDOT RDM (2018) Page 3-61, Table 3-18 & Table 3-1
Min. Outside Shoulder Width [ft]	10 ^{9,11}	8 (desirable) 6 (minimum)	8	8	-	-	TxDOT RDM (2018) Page 3-62, Table 3-18 & Table 3-1
Min. Inside Shoulder Width [ft]	10 ^{10,11}	2 (roadway) 4 (structure)	2 (roadway) 4 (structure)	2 (roadway) 4 (structure)	-	-	TxDOT RDM (2018) Page 3-62, Table 3-18 & Table 3-1
Min. Lateral Offset [ft]	1.5 minimum from the face of curb where curb is present 1.0 minimum from the toe of barrier to the edge of traveled way						TxDOT RDM (2018) RDM Page 2-45
Roadway Pavement Cross Slope [%]	2.0 ¹² 2.5 ¹²	2.0 ¹² 2.5 ¹²	2.0	2.0	2.0	2.0	TxDOT RDM (2018) Page 2-33
Design Vehicle	WB-62						TxDOT RDM (2018) Page 7-25 (bottom of page)
Min. Distance Between Successive Ramps – Entrance Followed by Exit with Auxiliary Lane [ft]	1500 (measured from nose of gore to nose of gore)				-		TxDOT RDM (2018) Figure 3-37
Min. Distance Between Successive Ramps – Entrance Followed by Exit without Auxiliary Lane [ft]	2000 (measured from nose of gore to nose of gore)				-		TxDOT RDM (2018) Figure 3-37
Min. Distance Between Successive Ramps – Exit Followed by Exit without Auxiliary Lane [ft]	1000 (measured from back of gore to back of gore)				-		TxDOT RDM (2018) Figure 3-37
Min. Border Width (face of curb to ROW line) [ft]	20 (desirable) 15 (minimum)						TxDOT RDM (2018) Table 3-1
Minimum Sidewalk and SUP Width [ft]	-				8-10 ¹³ (SUP) 6 ¹⁵ (Sidewalk)		TxDOT RDM (2018) Table 3-1 Per Schematic Plan

Criteria	EXPRESS LANES AND GENERAL PURPOSE LANES	RAMPS	DIRECT CONNECTORS (DC)	COLLECTOR-DISTRIBUTOR (C-D)	TURNAROUNDS	FRONTAGE ROADS	REFERENCE
Functional Classification	Urban Freeway	Urban Freeway	Urban Freeway	Urban Arterial	Turn-Around	Urban Arterial	Per Schematic Plan
Design Speed [mph]	60	40	40	40	15	40	Per Schematic Plan
Max. Sidewalk Cross Slope [%]	-				1.0 ¹⁶ (SUP) 1.5 ¹⁷ (Sidewalk)		AASHTO GDBF (2012) pages 5-14 & 5-15 TxDOT RDM Page 2-41 TxDOT Austin District Standard
Clear Zone (from edge of travel lane) [ft]	30	16		10 Uncurbed 6 Curbed (desirable) 4 Curbed (minimum from face of curb)	6 Curbed (desirable) 4 Curbed (minimum from face of curb)		TxDOT RDM (2018) Table 2-12
Max. Front Slope (within clear zone) [V:H]	1:6						TxDOT RDM (2018) Page 2-43
Max. Front Slope (outside clear zone) [V:H]	1:4 (desirable) 1:3 (absolute) ¹⁴						TxDOT RDM (2018) Page 2-43
Max. Back Slope [V:H]	1:4 (desirable) 1:3 (absolute) ¹⁴						TxDOT RDM (2018) Page 2-43

NOTES:

RDM: *TxDOT Roadway Design Manual (2018)*, AASHTO GDBF: *AASHTO Guide for the Development of Bicycle Facilities (2012, 4th Edition)*, ROW: Right-of-way, SUP: Shared Use Path

¹ US 183 Southbound maximum profile grade -4.36% from STA. 1187+95 to STA. 1190+50 as shown at *Exhibit D – Item 3.7.1 – Schematic Plans*.

² NB Exit Ramp South of Loop 360 maximum profile grade -7.74% to match existing as shown at *Exhibit D – Item 3.7.1 – Schematic Plans*.

NB Exit Ramp to Anderson Mill Road maximum profile grade 4.46% as shown at *Exhibit D – Item 3.7.1 – Schematic Plans*.

³ DC from SB 183 at SB Loop 1 maximum profile grade -6.53% to match existing as shown at *Exhibit D – Item 3.7.1 – Schematic Plans*.

Deferred Work's DC downgrade of 6% is allowed to achieve standard vertical clearance under Steck Avenue bridge as shown at *Exhibit D – Item 3.7.1 – Schematic Plans*.

⁴ Minimum K-Value for Sag Curve NB Entrance Ramp South of Great Hills Trail is 37 as shown at *Exhibit D – Item 3.7.1 – Schematic Plans* meeting comfort criteria.

See TxDOT RDM (2018), page 2-31 for safety lighting considerations/requirements where comfort criteria are applied.

⁵ Minimum values for proposed U-turns with less than 16'-6" vertical clearance can be used as shown at *Exhibit D – Item 3.8.1 – Bridge Layouts*.

Minimum vertical clearance over Lake Creek Parkway is 16'-4" as shown at *Exhibit D – Item 3.7.1 – Schematic Plans*.

Maintain existing minimum vertical clearance under W. Anderson Lane/Spicewood Springs Road. *Exhibit D – Item 3.7.1 – Schematic Plans* indicates 16'-2", however the DB Contractor to verify existing value.

⁶ Loop 1 and US 183 general purpose lane width Exceptions have been approved for the Project and are included in *Exhibit D – Item 3.3.2 – Approved Design Exceptions*:

Loop 1 SB & NB general purpose lanes from US 183 to RM 2222: 11'-wide general purpose lanes from STA. 205+00 to STA. 365+00.

US 183 SB & NB general purpose lanes from 4000' north of SH 45 to south of McNeil Drive (County Line): 11'-wide general purpose lanes from STA. 791+00 to STA. 999+58.07 (Station equation 999+58.07 BK = 0+00.00 AH).

US 183 SB & NB general purpose lanes from south of McNeil Drive to 3,000' south of Loop 1: 11'-wide general purpose lanes from STA. 0+00 to STA. 270+00 (Station equation 999+58.07 BK = 0+00.00 AH).

⁷ Turnaround design shall meet turning movement of Design Vehicle, Clear Zone and Stopping Sight Distance requirements.

⁸ Provide wider frontage road lanes as shown at *Exhibit D – Item 3.7.1 – Schematic Plans* (locations and widths).

⁹ Loop 1 and US 183 Outside Shoulder width Exceptions have been approved for the Project and are included in *Exhibit D – Item 3.3.2 – Approved Design Exceptions*:

Loop 1 NB exit to US 183 NB DC gore: 6'-wide outside shoulder from STA. 217+00 to STA. 221+00.

Loop 1 NB under Steck Avenue: 8'-wide outside shoulder from STA. 241+00 to STA. 255+00.

Loop 1 SB under Steck Avenue: 8'-wide outside shoulder from STA. 245+00 to STA. 249+00.

Loop 1 NB under Anderson Lane: 8'-wide outside shoulder from STA. 272+00 to STA. 276+00.

Loop 1 SB under Anderson Lane: 6'-wide outside shoulder from STA. 268+00 to STA. 276+00.

Loop 1 SB under Far West Boulevard: 8'-wide outside shoulder from STA. 310+00 to STA. 314+00.

Loop 1 SB between US 183 and Steck Avenue: 6'-wide outside shoulder from STA. 214+72 to STA. 236+13.

US 183 NB at RM 620 overpass: 5'-wide outside shoulder from STA. 822+00 to STA. 838+00.

US 183 NB at Anderson Mill Road overpass: 8'-wide outside shoulder from STA 902+00 to STA. 921+50.

US 183 SB at Anderson Mill Road overpass: 8'-wide outside shoulder from STA 902+00 to STA. 910+00.

US 183 NB Duval entrance gore: 4'-wide shoulder from STA. 47+00 to STA 50+00 (Station equation 999+58.07 BK = 0+00.00 AH).

US 183 SB at Oak Knoll entrance gore: 4'-wide shoulder from STA. 62+00 to STA 68+00.

US 183 SB at Oak Knoll exit gore: 4'-wide shoulder from STA. 65+00 to STA 72+00.

US 183 SB at Duval Road overpass: 6'-wide shoulder from STA. 80+00 to STA. 86+00.

US 183 SB at Balcones Woods bridge: 4'-wide shoulder from STA. 121+00 to STA 127+00.

US 183 SB at Loop 1 and UPRR overpasses: 8'-wide outside shoulder from STA 232+00 to STA. 255+00.

US 183 NB at Loop 1 and UPRR overpasses: 8'-wide outside shoulder from STA 230+00 to STA. 250+00.

¹⁰ Loop 1 and US 183 Inside Shoulder width Exceptions have been approved for the Project and are included in *Exhibit D – Item 3.3.2 – Approved Design Exceptions*:

Loop 1 NB from south of US 183 to south of Anderson Lane: 4'-wide inside shoulder from STA. 210+00 to STA. 285+00.

Loop 1 NB under Far West Boulevard: 4'-wide inside shoulder from STA. 305+00 to STA. 317+00.

Loop 1 SB from south of US 183 to south of Steck Ave: 4'-wide inside shoulder from STA. 210+00 to STA. 257+00.

Loop 1 SB north of RM 2222: 4'-wide inside shoulder from STA. 353+00 to STA. 369+00.

US 183 SB & NB from 4000' north of SH 45 to south of McNeil Drive (County Line): 4'-wide inside shoulder from STA. 790+00 to STA. 999+58.07 (Station equation 999+58.07 BK = 0+00.00 AH).
US 183 SB & NB from south of McNeil Drive to south of Loop 1: 4'-wide inside shoulder from STA. 0+00 to STA. 270+00 (Station equation 999+58.07 BK = 0+00.00 AH).

- ¹¹ A minimum 4-ft buffer with vertical delineators is required between inside general purpose lane and outside express lane as shown at Exhibit D – Item 3.7.1 – Schematic Plans.
- ¹² See Exhibit D – Item 3.7.1 – Schematic Plans for cross-slope break locations from 2.0% to 2.5%. Allowance will be made to match existing cross slope as long as all other design criteria is met.
- ¹³ See plan view of Exhibit D – Item 3.7.1 – Schematic Plans for limits of 8' and 10' wide SUP.
- ¹⁴ Stability analysis and approval by Central Texas Regional Mobility Authority is required for slopes steeper than 1:4 with heights more than 3 feet.
- ¹⁵ Sidewalk width may be reduced to 4 feet for a distance of no more than 50 feet where insufficient space is available to locate street fixtures (elements such as sign supports, signal poles, utility poles and related elements, fire hydrants, and controller cabinets that are not intended for public use) outside of the 5 feet minimum clear width.
- ¹⁶ 1% cross slope is desirable and 2% maximum on Shared Use Path.
- ¹⁷ 1.5% cross slope is desirable and 2% maximum on sidewalk.

Central Texas Regional Mobility Authority
Technical Provisions
For
183 North Mobility Project

ATTACHMENT 12-1
BRIDGE CONDITION RATING SUMMARY

BRIDGE CONDITION RATING SUMMARY

LATTITUDE	LONGITUDE	STRUCTURE NAME	NBI	FEATURE CROSSED	FACILITY CARRIED	BUILT	LAST INSP.	DECK (ITEM 58)														SUPERSTRUCTURE (ITEM 59)										SUBSTRUCTURE (ITEM 60)				APPROACHES (ITEM 65)							MISCELLANEOUS																		
								DECK - RATING		WEARING SURFACE	JOINTS, EXPANSION, OPEN	JOINTS, EXPANSION, SEALED	JOINTS, OTHER	DRAINAGE SYSTEM	CURBS, SIDEWALKS, PARAPETS	MEDIAN BARRIER	RAILINGS	RAILING PROTECTIVE COATING	DELINEATIONS (CURVE MARKERS)	OTHER	MAIN MEMBERS - STEEL	MAIN MEMBERS - CONCRETE	MAIN MEMBERS - TIMBER	MAIN MEMBERS CONNECTIONS	FLOOR SYSTEM MEMBER	FLOOR SYSTEM CONNECTION	SECONDARY MEMBER	SECONDARY MEMBERS CONNECTION	EXPANSION BEARING	FIXED BEARING	STEEL PROTECTIVE COATING	OTHER	ABUTMENT CAP	ABOVE GROUND	BELOW GROUND OR FOUNDATION	BACKWALLS & WINGWALL	CONCRETE - CAP	CAP - STEEL	CAPS - TIMBER	ABOVE GROUND - CONCRETE	ABOVE GROUND - STEEL	ABOVE GROUND - TIMBER	ABOVE GROUND - MASONRY	BELOW GROUND OR FOUNDATION	COLLISION PROTECTION SYSTEM	STEEL PROTECTIVE COATING	EMBANKMENT	EMBANKMENT RETAINING WALLS	SLOPE PROTECTION	ROADWAY	RELIEF JOINTS	DRAINAGE	GUARDFENCE	DELINEATION	SIGHT DISTANCE	OTHER	SIGNS	ILLUMINATION	WARNING DEVICES	UTILITY LINES	OTHERS
								7	8																																																				
30.40743290	97.74489075	US 183 NB AT BALCONES WOOD DR	14-227-0-0151-06-068	BALCONES WOOD DR	US 183 NB	1995	2017	7	N	N	8	8	8	N	N	7	N	N	8	N	8	N	8	N	8	N	7	N	8	7	7	N	N	8	N	N	8	N	8	N	8	N	7	7	8	6	8	8	7	N	8	N	8	8	N	N	N				
30.40833624	97.74540015	US 183 SB AT BALCONES WOOD DR	14-227-0-0151-06-069	BALCONES WOOD DR	US 183 SB	1995	2017	7	N	N	8	N	8	N	N	7	N	N	8	N	8	N	8	N	8	N	7	N	8	7	7	N	N	8	N	N	8	N	8	N	8	N	7	7	8	6	8	8	7	N	8	N	8	8	N	N	N				
30.40033720	97.74601925	US 183 NB AT BRAKER LN	14-227-0-0151-06-070	BRAKER LN	US 183 NB	1995	2017	7	N	N	8	8	8	N	N	7	N	N	8	N	8	N	8	N	8	N	7	N	8	7	8	N	N	8	N	N	8	N	8	N	8	N	7	7	8	6	8	8	7	8	8	N	8	8	N	N	N				
30.40033220	97.74591724	US 183 SB AT BRAKER LN	14-227-0-0151-06-071	BRAKER LN	US183 SB	1995	2017	7	N	N	8	8	8	N	N	7	N	N	8	N	7	N	8	N	8	N	7	N	8	7	8	N	N	8	N	N	8	N	8	N	8	N	7	7	8	6	8	8	7	N	8	N	8	8	N	N	N				
30.39417245	97.74653516	US 183 NB AT GREAT HILLS TRAIL	14-227-0-0151-06-072	GREAT HILLS TRAIL	US 183 NB	1995	2017	7	N	N	8	N	8	N	N	7	N	N	8	N	8	N	8	N	8	N	7	N	8	6	8	N	N	8	N	N	8	N	8	N	8	N	7	7	8	6	8	8	7	N	8	N	7	8	N	N	N				
30.39417245	97.74662716	US 183 SB AT GREAT HILLS TRAIL	14-227-0-0151-06-073	GREAT HILLS TRAIL	US 183 SB	1995	2017	7	N	N	8	N	8	N	N	7	N	N	8	N	7	N	8	N	8	N	7	N	8	6	8	N	N	8	N	N	8	N	8	N	8	N	7	7	8	6	8	8	7	N	8	N	8	8	N	N	N				
30.42917287	97.75871074	US 183 NB AT OAK KNOLL DR	14-227-0-0151-06-076	OAK KNOLL DR	US 183 NB	1997	2017	7	N	N	7	N	8	N	6	N	N	8	N	8	N	8	N	8	N	8	8	8	8	8	8	N	N	7	N	8	7	8	N	8	N	8	N	7	8	8	7	8	8	7	N	8	N	8	8	N	N	N			
30.42922382	97.75992940	US 183 SB AT OAK KNOLL DR	14-227-0-0151-06-077	OAK KNOLL DR	US 183 SB	1997	2017	7	N	N	7	N	8	N	7	N	N	8	N	8	N	8	N	8	N	8	8	8	8	8	8	N	N	7	N	8	6	8	N	8	N	8	N	7	8	8	7	8	8	7	N	8	N	8	8	N	N	N			
30.41869682	97.74657051	US 183 NB AT DUVAL RD	14-227-0-0151-06-078	DUVAL RD	US 183 NB	1997	2017	7	N	N	6	8	8	N	6	N	N	8	N	8	N	8	N	8	N	8	8	8	8	8	N	N	7	N	8	7	7	N	8	N	8	N	8	N	7	7	8	6	8	8	7	N	8	N	8	8	N	N	N		
30.41951423	97.74719932	US 183 SB AT DUVAL RD	14-227-0-0151-06-079	DUVAL RD	US 183 SB	1997	2017	7	N	N	8	N	8	N	6	N	N	8	N	8	N	8	N	8	N	8	8	8	8	8	N	N	7	N	8	7	7	N	8	N	8	N	8	N	7	7	7	6	8	8	7	N	8	N	8	8	N	N	N		
30.43409992	97.76875219	US 183 NB AT SPICEWOOD SPRINGS/MCNEIL RD	14-246-0-0151-05-104	SPICEWOOD SPRINGS/MCNEIL RD	US 183 NB	1998	2017	7	N	N	7	8	8	N	7	N	N	8	N	7	N	8	N	8	N	8	8	8	8	8	N	N	7	6	8	6	6	N	N	7	N	N	8	N	6	6	6	7	7	8	7	8	8	N	8	8	N	N	N		
30.43484886	97.77130924	US 183 SB AT SPICEWOOD SPRINGS/MCNEIL RD	14-246-0-0151-05-105	SPICEWOOD SPRINGS/MCNEIL RD	US 183 SB	1998	2017	7	N	N	7	7	8	N	7	N	N	8	N	6	N	8	N	8	N	8	8	8	8	8	N	N	7	7	8	7	6	N	N	7	N	N	8	N	8	7	8	7	8	8	N	8	8	N	N	N					
30.46926492	97.79751089	US 183 SB AT SH 45 / RM 620	14-246-0-0151-05-107	SH 45 / RM 620	US 183 SB	2003	2017	7	N	N	8	7	8	N	7	N	N	8	N	7	N	8	N	8	N	8	8	8	8	N	N	8	7	8	7	6	N	N	7	N	N	8	8	8	7	8	8	7	8	8	8	N	8	7	N	N	N				
30.46513564	97.79535845	US 183 NB AT PECAN PARK BLVD	14-246-0-0151-05-108	PECAN PARK BLVD	US 183 NB	2003	2017	7	N	N	8	8	8	N	7	N	N	8	N	7	N	8	N	8	N	8	8	8	8	8	N	N	8	6	8	7	7	N	8	N	7	N	N	8	N	7	6	8	8	7	N	8	N	8	8	N	N	N			
30.46577752	97.79614937	US 183 SB AT PECAN PARK BLVD	14-246-0-0151-05-109	PECAN PARK BLVD	US 183 SB	2003	2017	7	N	N	7	7	8	N	7	N	N	8	N	7	N	8	N	8	N	8	8	8	8	N	N	8	7	8	7	7	N	8	N	8	N	8	N	7	7	7	8	8	7	N	8	N	8	8	N	N	N				
30.46094756	97.79370559	US 183 NB AT LAKE CREEK PKWY	14-246-0-0151-05-110	LAKE CREEK PKWY	US 183 NB	2003	2017	7	N	N	7	8	8	N	6	N	N	8	N	7	N	8	N	8	N	8	8	8	8	N	N	7	7	8	7	7	N	8	N	7	N	N	8	N	7	8	7	7	8	7	N	8	N	8	8	N	N	N			
30.46158694	97.79442509	US 183 SB AT LAKE CREEK PKWY	14-246-0-0151-05-111	LAKE CREEK PKWY	US 183 SB	2003	2017	7	N	N	7	8	8	N	8	N	N	8	N	7	N	8	N	8	N	8	8	8	8	N	N	7	7	8	7	7	N	8	N	7	N	N	8	N	7	8	7	7	8	7	N	8	N	8	8	N	N	N			
30.44842246	97.79011374	US 183 NB AT ANDERSON MILL RD	14-246-0-0151-05-112	ANDERSON MILL RD	US 183 NB	2003	2017	7	N	N	7	8	8	N	7	N	N	8	N	7	N	8	N	8	N	8	8	8	8	N	N	7	7	8	7	6	N	N	7	N	N	8	N	8	7	8	7	7	8	7	N	8	N	8	8	N	N	N			
30.44910847	97.79088138	US 183 SB AT ANDERSON MILL RD	14-246-0-0151-05-113	ANDERSON MILL RD	US 183 SB	2003	2017	7	N	N	7	8	8	N	7	N	N	8	N	7	N	8	N	8	N	8	8	8	8	N	N	7	7	8	7	6	N	N	7	N	N	8	N	8	7	8	7	7	8	7	N	8	N	8	8	N	N	N			
30.47335249	97.79903505	US 183 SB ML AT LAKELINE MALL DR	14-246-0-0151-05-128	LAKELINE MALL DR	US 183 SB	2006	2017	7	N	N	8	N	8	N	7	N	N	7	N	8	N	8	N	8	N	8	8	8	8	N	N	8	8	8	8	N	N	8	N	N	8	N	8	8	8	7	7	8	7	N	8	N	8	8	N	N	N				
30.47347599	97.79895966	US 183 NB ML AT LAKELINE MALL DR	14-246-0-0151-05-129	LAKELINE MALL DR	US 183 NB	2006	2017	7	N	N	7	N	8	N	7	N	N	7	N	8	N	8	N	8	N	8	8	8	8	N	N	8	8	8	8	N	N	8	N	N	8	N	8	8	8	7	7	8	8	N	8	N	8	8	N	N	N				

BRIDGE CLASS CULVERT CONDITION RATING SUMMARY

N	NOT APPLICABLE			
9	EXCELLENT CONDITION			
8	VERY GOOD CONDITION			
7	GOOD CONDITION — SOME MINOR PROBLEMS			
6	SATISFACTORY CONDITION — MINOR DETERIORATION OF STRUCTURAL ELEMENTS (LIMITED)			
5	FAIR CONDITION - MINOR DETERIORATION OF STRUCTURAL ELEMENTS (EXTENSIVE)			
4	POOR CONDITION - DETERIORATION SIGNIFICANTLY AFFECTS STRUCTURAL CAPACITY			
3	SERIOUS CONDITION - DETERIORATION SIGNIFICANTLY AFFECTS STRUCTURAL CAPACITY			
2	CRITICAL CONDITION - BRIDGE SHOULD BE CLOSED UNTIL REPAIRED			
1	FAILING CONDITION - BRIDGE CLOSED BUT REPAIRABLE			
0	FAILED CONDITION - BRIDGE CLOSED BUT BEYOND REPAIR			

NBI	ROUTE	FEATURE CROSSED	CULVERT DISCRIPTION	RATING (ITEM 62)
14-246-0151-05-075	US 183	Lake Creek	6-10'x8' Precast concrete multiple box Culvert at 15 degree right forward skew	6
14-227-0151-06-052	US 183	Draw	3-Box concrete culvert 498 LF at 15 degree right forward skew	6
14-227-3136-01-081	Loop 1 NB Frtg Rd	Draw	2 -Barrel 10'x6' concrete multiple box culvert	7
14-227-3136-01-095	LP 1 SB Frtg Rd to 183 NB Frtg Rd	Draw	5- Barrel 6'x5' concrete multiple box culvert at 30 degree right forward skew	7
14-227-3136-01-127	Loop 1	Draw	2 -Barrel 10'x6' concrete multiple box culvert at 12 degree right forward skew	7

Central Texas Regional Mobility Authority
Technical Provisions
For
183 North Mobility Project

ATTACHMENT 15-1
IMPACT ASSESSMENT EVALUATION
REQUIREMENTS

"Drainage Area/ Water Quality Points of Interest"	HYDROLOGIC AND HYDRAULIC REFERENCE NOTES		POND REFERENCE NOTES	REQUIREMENTS	
	Stream	Risk Potential	Project Facility (Existing) [Proposed]	Technical Provision Requirements	
				Hydrologic & Hydraulic	WQ
ALL POI					Percent TSS Annual load removals described in Attachment 15-1 are environmental commitments. However, the Project shall achieve no net increase in TSS annual loading from 1987 baseline impervious cover (with the exception of Rattan, Shoal, and Bull creeks) to Ultimate Design impervious cover. For the Rattan Creek watershed, the DB Contractor shall use the 1999 baseline impervious cover. For Shoal Creek and Bull Creek, the DB Contractor shall use the 1992 baseline impervious cover. These baselines acknowledge the previous impervious cover permitted by TCEQ without TSS treatment. The Ultimate Design impervious cover (referred to as Ultimate Post Project impervious cover), excludes the FM620/SH 45 direct connectors and associated improvements.
A	Lake Creek	Existing structures located in floodplain. No complaints per City of Austin data. Medium risk potential.	Line B and Line C Pond (WQ extended detention) Pond E (WQ vertical gravel filter) Pond F (WQ vertical gravel filter) Pond G (WQ vertical gravel filter) Main Pond (detention) North Pond (detention) South Pond (detention) 620 Median Pond (WQ sedimentation - sand filtration) Lakecreek 1A (vault WQ sedimentation - sand filtration) [surface WQ batch detention] Lakecreek 1B (vault WQ sedimentation - sand filtration) [surface WQ batch detention] Lakecreek 1C (vault WQ sedimentation - sand filtration) [surface WQ batch detention]	From downstream of project to NRCS Dam #8, no more than 0.2% increase in peak flows for the 100-year storm event. From downstream of project to NRCS Dam #8, no rise greater than 0.01-ft in WSE for the 100-year storm event.	Remove existing underground vaulted ponds and replace with Batch Detention ponds open to the surface. Install longitudinal barriers, access and maintenance requirements per the Technical Provisions. Provide treatment for 80% of increase in TSS load in addition to the previously permitted (record drawings) load removal.
B	Lake Creek Trib 2	Flow is contained in channel. No complaints per City of Austin data. Low risk potential.	Hymeadow Pond 2A (vault WQ sedimentation - sand filtration) [surface WQ batch detention] Hymeadow Pond 2B (vault WQ sedimentation - sand filtration) [surface WQ batch detention] Hymeadow Pond 2C (vault WQ sedimentation - sand filtration) [surface WQ batch detention] Hymeadow Pond 2D1 (vault WQ sedimentation - sand filtration) [surface WQ batch detention] Hymeadow Pond 2D2 (vault WQ sedimentation - sand filtration) [surface WQ batch detention]	From downstream of project to confluence with Lake Creek mainstem, no more than 0.75% increase in peak flows for 100-year storm event. From downstream of project to Coppers Creek Drive, no rise greater than 0.02-ft in WSE for the 100-year storm event. From Coppers Creek Drive to confluence with Lake Creek mainstem, no rise greater than 0.06-ft in WSE immediately upstream of Meadowheath Drive and no rise greater than 0.03-ft in WSE at other locations for the 100-year storm event.	Remove existing underground vaulted ponds and replace with Batch Detention ponds open to the surface. Install longitudinal barriers, access and maintenance requirements per the Technical Provisions. Provide treatment for 80% of increase in TSS load in addition to the previously permitted (record drawings) load removal.
C	Lake Creek Trib 2	Flow is contained in channel. No known complaints per City of Austin data. Low risk potential.	Pond Springs Pond (WQ sedimentation - sand filtration) [WQ expansion] Pond Springs Pond (detention)	None	Provide treatment for 80% of increase in TSS load in addition to the previously permitted (record drawings) load removal. Remove existing gabion wall
D	Lake Creek Trib 3	Not mapped in Best Available effective model. No complaints per City of Austin data. Low risk potential.	Woods Pond (WQ wet pond) [WQ batch detention with stacked detention]	EPA-SWMM shall be used to model the culvert outfall from the ROW to the Woods Pond. From downstream of project to NRCS Dam #8, no increase in peak flows for the 100-year storm event. From downstream of project to NRCS Dam #8, no rise in WSE for the 100-year storm event.	Provide treatment for 80% of increase in TSS load in addition to the previously permitted (record drawing) load removal. Pond outfall system shall be surveyed and reviewed for function and replaced per the Technical Provisions Section 15 and approved by the Mobility Authority.

"Drainage Area/ Water Quality Points of Interest"	HYDROLOGIC AND HYDRAULIC REFERENCE NOTES		POND REFERENCE NOTES	REQUIREMENTS	
	Stream	Risk Potential	Project Facility (Existing) [Proposed]	Technical Provision Requirements	
				Hydrologic & Hydraulic	WQ
E	Rattan Creek	No structures in mapped floodplain. No complaints per City of Austin data. Low risk potential.	Pond E [WQ batch detention]	<p>From downstream of project to Los Indios Trail, no more than 0.75% increase in peak flows for 100-year storm event and no rise greater than 0.04-ft in WSE.</p> <p>From Los Indios Trail to Tamayo Drive, no more than 0.3% increase in peak flows for 100-year storm event, no rise in WSE greater than 0.02-ft in WSE, and no rise greater than 0.01-ft in WSE at locations with structural impacts.</p> <p>From Tamayo Drive to W. Parmer Lane, no more than 0.15% increase in peak flows for 100-year storm event and no rise in WSE greater than 0.01-ft.</p>	<p>Provide treatment for 85% of increase in TSS load.</p> <p>Maintain pedestrian access</p> <p>Maintain existing conveyance along Pond Springs Rd.</p>
F	Walnut Creek Trib 7	Structures in the floodplain near Black Angus Dr. High risk potential	West Cow Path Pond, AKA Duval Pond (WQ sedimentation - sand filtration) [WQ batch detention with stacked detention]	<p>Peak flows for the 2-, 10-, 25-, 50-, and 100-year storm events shall be mitigated to 0 increase downstream of West Cow Path Pond to Bull Run. No rise in WSE downstream of project to Bull Run.</p> <p>From Bull Run to Black Angus Drive, no more than 0.03% increase in 100-year storm event peak flows and no more than 0.02-ft increase in WSE</p> <p>From Black Angus Drive to confluence of Walnut Creek Tributary 7A, no more than 0.55% increase in 100-year storm event peak flows, no more than 0.03-ft rise in WSE, and no rise in WSE at locations with structural impacts.</p>	<p>Provide treatment for 80% of increase in TSS load in addition to the previously permitted (record drawing) load removal.</p> <p>The pond is subject to a memorandum of understanding with the City of Austin and shall also be designed in accordance with DCM and ECM.</p> <p>Provide low flow bypass of water quality pond to eliminate groundwater saturation of the sedimentation and filtration bed.</p>
G	Walnut Creek Trib 7A	Structures in the floodplain along Calle Verde Dr. High risk potential	Seton Pond (WQ sedimentation - sand filtration) [WQ batch detention with stacked detention]	<p>Peak flows for the 2-, 10-, 25-, 50-, and 100-year storm events shall be mitigated to 0 increase downstream of Seton Pond to confluence with Walnut Creek Tributary 7.</p> <p>No rise in WSE downstream of project to the private driveway of National Instruments Corp. located northwest of Mopac.</p> <p>From the private driveway of National Instruments Corp. to the confluence with Walnut Creek Tributary 7, no more than 0.01-ft rise in WSE.</p>	<p>Provide treatment for 80% of increase in TSS load in addition to the previously permitted (record drawing) load removal.</p> <p>The pond is subject to a memorandum of understanding with the City of Austin and shall also be designed in accordance with DCM and ECM.</p> <p>Pond outfall system shall be surveyed and reviewed for function and replaced per the Technical Provisions Section 15 and approved by the Mobility Authority.</p>
360	Bull Creek	No changes in flows. Channel contained in ROW. Low risk potential.	Pond360 [WQ batch detention]	None	Provide treatment for 80% of increase in TSS load.
H	Shoal Creek	Structures in the 100-year floodplain along Crosscreek Dr., Milway Dr., Shoal Creek Blvd., Bullard Dr., White Rock Dr., and Greenlawn Pkwy. High risk potential	MoPac Pond 1 (detention) MoPac Pond 2 (detention) Pond H [WQ batch detention]	<p>From downstream of project to Crosscreek Drive, no more than 0.25% increase in peak flows for the 100-year storm event and no rise in WSE at location with structural impacts.</p> <p>From Crosscreek Drive to Hancock Drive Road, no increase in peak flows and no rise in WSEL for the 2-, 10-, 25-, 50-, 100-year storm events.</p>	Provide treatment for 80% of increase in TSS load.

Central Texas Regional Mobility Authority
Technical Provisions
For
183 North Mobility Project

ATTACHMENT 21-1
TOLL FACILITY AND
ITS RESPONSIBILITY MATRIX

Primary Responsibility: P	Support Responsibility: S		Coordination Responsibility Only: C			No Responsibility: N	
Element/Task/Component/ Sub-system	DB Contractor (DB)		System Integrator (SI)			Comments Other Responsibility/Information	
	Design	Procure	Install/ Construct	Design	Procure		Install / Construct
GENERAL REQUIREMENTS							
Schedule	P	P	P	S	C	S	DB shall accommodate and incorporate the SI scheduled activities into the DB schedule. All schedule changes or updates which impact the SI tasks must be agreed to by the SI prior to submittal to the Mobility Authority. A monthly schedule must be distributed and incorporate any SI updates or changes.
Request for Early Opening	P	P	P	S	S	S	The SI must be able to match schedule request for early opening. SI must be allowed early unencumbered access in order to meet early opening request.
Design Package – Installation and Electrical Design and Plans	P	P	P	C	N	C	DB to incorporate all toll and ITS requirements and specifications into all versions of the Structural and Electrical Design Packages. SI to provide DB approval of packages prior to issuance of Released For Construction (RFC) plans. DB will coordinate installation activities with SI.
Grading	P	P	P	C	N	C	DB to incorporate SI requirements with respect to grading into toll and ITS system design. DB to place infrastructure with ease of maintenance access and installation as a priority.
Drainage	P	P	P	C	N	C	No culverts or pipes under toll zones.
Utilities/Electrical Services	P	P	P	S	C	C	SI to provide specific requirements for the Toll and/or Mobility Authority ITS Systems. DB to incorporate into the ITS and toll facilities design, and construct power, utilities interface, and all power infrastructure. DB to provide power to the Toll System pad and Mobility Authority ITS locations as required by the SI. SI to terminate power to toll and ITS sites owned by the Mobility Authority.
Traffic Control/Safe work zone	P	P	P	S	N	C	SI to provide DB detailed lane closure requirements, schedule for installation and

Primary Responsibility: P	Support Responsibility: S		Coordination Responsibility Only: C			No Responsibility: N	
Element/Task/Component/ Sub-system	DB Contractor (DB)		System Integrator (SI)			Comments Other Responsibility/Information	
	Design	Procure	Install/ Construct	Design	Procure		Install / Construct
						testing of tolling and Mobility Authority ITS equipment. DB to provide traffic control devices, and safe working conditions for SI during installation and testing of all toll and Mobility Authority ITS equipment.	
Field Office requirements	P	P	P	C	N	C	DB shall coordinate with the SI on space requirements for design and construction personnel.
Signing	P	P	P	C	N	S	All toll signing must be coordinated with and approved by the Mobility Authority. If toll price signs utilize changeable electronic signs, the DB will provide the static sign and the SI will provide the electronic insert (e.g. LED panels) and wireways needed to integrate the system. DB shall be responsible for coordinating with the SI to allow SI to install LED panels and wire ways on static signs while on the ground, at the roadside location, prior to mounting signs onto sign gantry/truss.
Striping	P	P	P	S	N	C	DB to coordinate with SI to identify final striping within the toll zone for the SI's loop (and/or other sensors/equipment) installations.
Lighting	P	P	P	S	C	S	Roadway and toll location lighting provided by DB. SI to provide lighting requirements in vicinity of toll locations and locations of other Toll System equipment. DB to confirm that lighting does not obstruct toll related signing or impede the Toll System.
Landscaping	P	P	P	C	N	N	
Fencing/Guardrail/Bollards/Concrete Barrier	P	P	P	S	C	C	SI to provide specific requirements for the toll pad placement, access and security fencing and/or barriers around toll and ITS equipment. DB to provide fencing and/or barriers at all toll pads per SI requirements. DB to install the appropriate barrier to protect toll pad equipment from traffic per SI requirements. DB to incorporate design requirements into design packages. DB to coordinate with SI to review and approve all versions of design packages.

Primary Responsibility: P	Support Responsibility: S		Coordination Responsibility Only: C			No Responsibility: N	
Element/Task/Component/ Sub-system	DB Contractor (DB)		System Integrator (SI)			Comments Other Responsibility/Information	
	Design	Procure	Install/ Construct	Design	Procure		
TOLL SYSTEM AND TOLL-RELATED ITS ELEMENTS OWNED BY THE MOBILITY AUTHORITY							
Locations and Layouts	P	P	P	S	C	C	SI to provide requirements for specific lane and facility layouts. DB to incorporate into Design Packages. DB to coordinate with SI to review all versions of design packages. SI to review and approve locations for the toll and ITS systems owned by the Mobility Authority. The DB will coordinate with SI during infrastructure installation activity.
Gantries/Foundation/Trusses/Junction boxes/Conduits/Grounding	P	P	P	S	C	S	SI to provide requirements for conduits (for SI installed power and communications cables, including specific requirements for below ground conduits for the loops), junction boxes, and power needs for the toll and ITS systems owned by the Mobility Authority. DB to incorporate into structural design, including electrical grounding, bonding, and power conductors. DB to provide and install gantry/truss for toll systems, gantry/truss foundations, junction boxes, cable trays/conduits/wireways, pull strings and bell ends for all conduits up to one foot above pole foundations and for conduits going up gantry columns. The DB will require SI to sign off on below-ground conduit stub outs pertaining to all toll and ITS facilities prior to finalizing toll zone pavement, toll equipment pads and foundations related to ITS installation.
Equipment Mounts on Brackets/Frames	S	N	C	P	P	P	SI to procure and install equipment for the toll and ITS systems owned by the Mobility Authority, and related cable and wiring, including communications from roadside cabinets to the equipment mounted on the gantries. SI to provide requirements for all brackets and frames needed to attach SI procured equipment to DB provided truss. SI to provide requirements for toll hanger, and the orientation of hangers mounted to Gantries. DB to furnish and install all toll hangers per SI requirements.
Equipment Brackets/Frames on Gantries	P	P	P	S	N	C	DB is to provide and install all toll hangers/brackets/frames on DB provided toll gantry/truss needed to attach all SI procured equipment. SI to provide locations for installation to the DB. DB to coordinate with SI to review hanger

Primary Responsibility: P	Support Responsibility: S		Coordination Responsibility Only: C			No Responsibility: N	
Element/Task/Component/ Sub-system	DB Contractor (DB)			System Integrator (SI)			Comments Other Responsibility/Information
	Design	Procure	Install/ Construct	Design	Procure	Install / Construct	
							shop drawings prior to fabrication.
Variable Toll Message Sign (VTMS) camera infrastructure (foundations (if needed), conduits, grounding, camera poles, and electrical services)	P	P	P	S	C	C	SI to provide requirements for camera mounts, conduits, junction boxes, power and data wiring and cables. SI shall also specify the locations of the VTMS controllers and cameras. SI to also provide requirements for placement with respect to maintenance access. DB to incorporate design requirements into Design Packages. DB to coordinate with SI to review all versions of design packages. SI to review and approve VTMS camera locations and infrastructure. DB to provide and install sign truss, truss foundations, poles, junction boxes, conduits, conduit pull strings, bell ends for all conduits, power circuit and power cable to the SI's cabinet.
VTMS cameras installation	S	N	C	P	P	P	SI to procure, install and terminate all cabinets and cameras, including all wiring except for the primary branch power circuit to the site's cabinet. SI shall also be responsible for testing VTMS camera systems.
Traffic Detection System (TDS) and Closed Circuit Television (CCTV) Camera installations	S	C	S	P	P	P	SI to procure, install and terminate all cabinets and traffic detection sensors, including all wiring except for the primary branch power circuit to the site's cabinet. SI shall also be responsible for testing TDS and CCTV systems.
TDS and CCTV Camera infrastructure: (Pole/Post-Mounts, supports, wiring and cables)	P	P	P	C	C	S	SI to provide requirements for placement with respect to maintenance access. DB to incorporate design requirements into Design Packages. DB to coordinate with SI to review all versions of design packages. SI to review and approve TDS and CCTV locations and infrastructure. DB to provide and install poles, pole foundations, junction boxes, conduits, conduits pull strings, bell ends for all conduits, power circuit and power cable to the SI's cabinet.

Primary Responsibility: P	Support Responsibility: S		Coordination Responsibility Only: C			No Responsibility: N	
Element/Task/Component/ Sub-system	DB Contractor (DB)			System Integrator (SI)			Comments Other Responsibility/Information
	Design	Procure	Install/ Construct	Design	Procure	Install / Construct	
Dynamic Message Sign (DMS) infrastructure: (foundations, conduits, grounding, DMS support structure, and electrical services)	P	P	P	S	C	C	SI to provide requirements for DMS dimensions (including single line DMS), mounts, conduits, support structure, power and data wiring, and cables. SI to provide requirements for placement with respect to maintenance access, power requirements, and weight of anticipated equipment for structural design purposes. DB to incorporate design requirements into Design Packages. DB to coordinate with SI to review all versions of design packages. SI to review and approve DMS locations and infrastructure. DB to provide and install support structure and foundations, conduits, junction boxes, vertical mounting supports, and power cables to the sign's main breaker.
DMS installation	S	N	S	P	P	P	SI to procure, install and terminate DMS (including single line DMS "bricks"), including all communication to the DMS. SI to terminate power circuit to the sign. SI shall also be responsible for testing DMS systems.
Automated lane closure gate system infrastructure: (foundation requirements, grounding, conduits, mounting/support structure, poles, and electrical services (as needed/required))	P	P	P	S	C	C	SI to provide requirements for gate system, including placement of each automated lane closure gate, mounting requirements/support structure, power and communication wiring, poles, foundations, conduits, junction boxes, power and data wiring, and cables. SI shall also specify the locations of the gate system, and placement with respect to maintenance access. DB to incorporate design requirements into Design Packages. DB to coordinate with SI to review all versions of design packages. SI to review and approve gate system locations and infrastructure. DB to provide and install foundations, junction boxes, conduits, conduit pull strings, bell ends for all conduits, power circuit and power cable to the SI's cabinet. DB shall also provide and install gate system equipment, including but not limited to: cabinets, poles, gate arms, etc.
Automated lane closure gate system installation	S	C	C	P	P	P	SI to install, configure and test equipment (e.g. hardware, software, etc.) and systems needed to operate the gate system. SI to terminate all wiring (power and communications) except for the primary

Primary Responsibility: P	Support Responsibility: S		Coordination Responsibility Only: C			No Responsibility: N	
Element/Task/Component/ Sub-system	DB Contractor (DB)		System Integrator (SI)			Comments Other Responsibility/Information	
	Design	Procure	Install/ Construct	Design	Procure		Install / Construct
						branch power circuit to the site's cabinet.	
Roadside Unit (RSU) Communication Device (e.g. dedicated short-range communications (DSRC), Bluetooth and/or Wi-F) installations	S	C	S	P	P	P	SI to procure, install and terminate all cabinets and roadside unit devices, including all wiring except for the primary branch power circuit to the site's cabinet. SI shall also be responsible for testing RSU devices.
RSU infrastructure: (Pole/Post-Mounts, supports, wiring and cables)	P	P	P	C	C	S	SI to provide requirements for placement with respect to maintenance access. DB to incorporate design requirements into Design Packages. DB to coordinate with SI to review all versions of design packages. SI to review and approve RSU locations and infrastructure. DB to provide and install poles, pole foundations, junction boxes, conduits, conduits pull strings, bell ends for all conduits, power circuit and power cable to the SI's cabinet.
Pavement structure, including special nonferrous zones and conduit stub-outs for in- pavement sensors/loops	P	P	P	S	N	C	SI to provide requirements for special pavement structures at toll and ITS locations. DB to incorporate design requirements into Design Packages. DB to coordinate with SI to review all versions of design packages. SI shall coordinate joint spacing to avoid conflicts with loop placement, and sign off on riser locations before concrete pour. DB to assure ferrous objects (i.e. rebar, grates, pipes, etc.) are not in the toll system's zone of influence. DB to locate loop risers after pavement is poured.
EQUIPMENT CABINETS							
Toll Equipment Cabinets	C	N	S	P	P	P	SI to provide size and number of cabinets needed for Mobility Authority Toll and ITS systems. DB shall incorporate location into site grading and drainage design. SI to procure and install environmentally controlled cabinets for ITS and toll systems owned by the Mobility Authority. The environmentally controlled enclosures provided by SI must comply with the America Society of Heating, Refrigeration, and Air

Primary Responsibility: P	Support Responsibility: S		Coordination Responsibility Only: C			No Responsibility: N	
Element/Task/Component/ Sub-system	DB Contractor (DB)		System Integrator (SI)			Comments Other Responsibility/Information	
	Design	Procure	Install/ Construct	Design	Procure		Install / Construct
						Conditioning Engineers: Thermal Guidelines for Data Processing Environments.	
Toll Equipment Cabinet Site (TEC) and Roadside Equipment Cabinet Base Slabs	P	P	P	S	N	C	SI to provide requirements for specific equipment weight and anchorages for all cabinets, generators, and auxiliary fuel tanks to the DB for all toll and ITS locations. DB to incorporate into design packages, and coordinate with the SI for review and approval. DB to coordinate with SI to verify conduit installations prior to concrete pours at all locations.
Security Communications at Toll System locations	C	N	C	P	P	P	SI to provide security communications for all toll and ITS system equipment.
TOLL SUB-SYSTEMS							
Automatic Vehicle Identification (AVI) Antennas and Readers	N	N	S	P	P	P	SI to procure and install AVI antennas and readers, system mounts, wiring and cables. SI will perform all AVI system installation and terminations, and to make the connections to the electronics in the cabinets.
Automatic Vehicle Classification and Detection (AVC) and (AVD)	N	N	S	P	P	P	SI to install, connect and terminate AVC and/or AVD systems mounted on the gantries and/or installed in the pavement to the electronics in the cabinets.

Primary Responsibility: P	Support Responsibility: S		Coordination Responsibility Only: C			No Responsibility: N	
Element/Task/Component/ Sub-system	DB Contractor (DB)		System Integrator (SI)			Comments Other Responsibility/Information	
	Design	Procure	Install/ Construct	Design	Procure		Install / Construct
In-Pavement Sensors	N	N	S	P	P	P	SI shall procure, install (e.g. saw cut pavement) and seal pavement sensors with approved sealant. DB to assure ferrous objects (i.e. rebar, grates, etc.) are not in the toll system's zone of influence. DB to assure longitudinal and transverse pavement joints in the non-ferrous pavement section in the toll zone do not conflict with SI conduit stub-up array in pavement section. DB to coordinate with SI to validate striping with pavement loop locations. DB to coordinate with SI and provide the SI with traffic control and access to toll zones for loop (and/or other sensors/equipment) installations prior to any final overlay paving (e.g. PFC).
Video Capture Sub-System (VCS/VES) Cameras, Illumination, Sensors and Servers	N	N	S	P	P	P	SI to provide and install Video Capture Sub- System (VCS/VES) cameras, illumination enclosures, mounts, camera wiring and cables. SI to connect and terminate VCS/VES cameras, illumination, sensors and servers. SI to make the connections to the electronics in the cabinets.
In-Lane Processing Servers and Electronics	N	N	N	P	P	P	SI to provide, install, connect, and terminate all electronics in the cabinet, and assure proper communications to the devices on the gantry and/or in the pavement.
VTMS Message Panels and Controllers	N	N	S	P	P	P	SI to provide, install, connect, and terminate VTMS message LED panels and controllers, including wireways, communication wiring and power wiring from the VTMS to the controllers in the cabinet. SI to provide VTMS LED panel sizes to the DB to be incorporated into the large guide sign design. DB shall be responsible for coordinating with the SI to allow SI to install LED panels and wire ways on static signs while signs are on the ground, at the roadside location, prior to mounting signs onto sign gantry/truss.
POWER DISTRIBUTION SUB-SYSTEM							

Primary Responsibility: P	Support Responsibility: S		Coordination Responsibility Only: C			No Responsibility: N	
Element/Task/Component/ Sub-system	DB Contractor (DB)			System Integrator (SI)			Comments Other Responsibility/Information
	Design	Procure	Install/ Construct	Design	Procure	Install / Construct	
Metered power service at each toll and ITS location	P	P	P	C	N	C	DB is responsible for metered power service for all toll and ITS locations. DB to procure and install electric service poles, and coordinate activation of power service with service provider. DB to provide all branch circuit breakers, and terminate all branch circuits at the service panel. DB to provide and install necessary conductors, ducts and junction/pull boxes, bell ends/pull strings and disconnect switch/fuse at the meter.
Metered power service at each location	C	N	C	P	P	P	SI to provide power requirements and special requirements for construction of utilities near each Toll and ITS System. DB to incorporate design requirements into Design Packages. DB to coordinate with SI to review all versions of design packages. SI shall provide and install all other wiring, switches, surge protection/suppression, etc. for power from the ATS at the toll pad for the Toll System equipment and other locations for ITS equipment. SI will terminate all power wiring for all branch circuits off the Service Panel to the Toll or ITS Site.
Generators and Automatic Transfer Switches (ATS)	S	N	C	P	P	P	SI to provide generators, ATS, generator cabinets, wiring, connect and terminate all power at roadside toll equipment locations.
Generator Power Source is Natural Gas	P	P	P	S	N	C	If natural gas is available, the DB shall provide, install and incorporate the gas lines into the roadway design. SI to coordinate and provide generator requirements including location for gas feed.
Generator Power Source is propane or diesel	S	S	S	P	P	P	If propane is used, DB will provide pad and conduit feed for propane fuel tank (10' minimum from generator). The SI shall provide and install the propane tank for the generator if natural gas is not a viable option for the project.

Primary Responsibility: P	Support Responsibility: S		Coordination Responsibility Only: C			No Responsibility: N	
Element/Task/Component/ Sub-system	DB Contractor (DB)		System Integrator (SI)			Comments Other Responsibility/Information	
	Design	Procure	Install/ Construct	Design	Procure		Install / Construct
Uninterruptible Power Supplies (UPS)	S	N	C	P	P	P	SI to provide and install Uninterruptible Power Supply Systems (UPS) in the cabinets. UPS will be required for the Toll Systems, WWD systems, DMS, VTMS and VTMS Cameras. SI will install all necessary wiring for the UPS. TDS, automated gate systems and CCTV Cameras (non-VTMS Cameras) will not require a UPS.
Lightning Protection & Grounding	P	P	P	S	C	C	SI to provide specific requirements for Toll and ITS systems equipment lightning protection and grounding. DB to incorporate design requirements into Design Packages. DB to coordinate with SI to review all versions of design packages. DB to furnish and install required lightning protection and grounding.
COMMUNICATIONS SUB-SYSTEMS							
Conduits/Ducts and Junction/Pull Boxes/Outlets	P	P	P	S	C	S	SI to provide specific communications design requirements including location of long-radius sweep conduit bends. DB to incorporate design requirements into Design Packages. DB to coordinate with SI to review all versions of design packages. DB to install conduits, junction boxes, bell ends with pull strings. The DB Contractor shall verify that all duct bank and conduits are clear/proofed and have pull strings available to the SI for installation of communications cables at least 30 days prior to the beginning of the toll system installation.
Fiber Optic cabling in conduits for Toll System and Toll-related ITS Elements	S	S	S	P	P	P	SI to provide fiber requirements for toll and ITS systems. DB to incorporate design requirements for duct back/conduit backbone and laterals into Design Packages. DB to coordinate with SI to review all versions of design packages.

Primary Responsibility: P	Support Responsibility: S		Coordination Responsibility Only: C			No Responsibility: N	
Element/Task/Component/ Sub-system	DB Contractor (DB)		System Integrator (SI)			Comments Other Responsibility/Information	
	Design	Procure	Install/ Construct	Design	Procure		Install / Construct
						SI to furnish and install fiber along the corridor to toll and ITS cabinets for Mobility Authority equipment. SI shall be responsible for testing all SI-installed fiber after installation.	
Toll Hardware in Cabinets and Computer Rack System	C	N	C	P	P	P	SI to provide and install all toll hardware within the cabinets. Equipment must be installed in a clean and organized manner and must not be affected by the environmental controls. The SI must provide and install the redundant environmental controls. SI to provide and install computer system racks to house the communication equipment including environmental controls.
Routers	C	N	C	P	P	P	SI to provide, install and configure the routers for connection from hub locations to the Mobility Authority's Traffic and Incident Management (TIM) Center.
Switches	N	N	C	P	P	P	SI to provide, install and configure the switches for connections from tolling and ITS locations to hub locations.
Firewalls	N	N	C	P	P	P	SI to provide, install and configure the necessary firewall for the toll system and ITS system. The toll and ITS systems shall be kept separate from each other and any other systems that utilize the TxDOT Hubs.
Patch/Distribution Panels	N	N	C	P	P	P	SI to provide and install all the necessary patch and distribution panels to provide a Fault Tolerant Single Mode Fiber Optic IP-Based Communication System.
Corridor Communications System	S	N	C	P	P	P	SI to provide Fault Tolerant Single Mode Fiber Optic IP-Based Communication System for toll systems.

Primary Responsibility: P	Support Responsibility: S		Coordination Responsibility Only: C			No Responsibility: N	
Element/Task/Component/ Sub-system	DB Contractor (DB)		System Integrator (SI)			Comments Other Responsibility/Information	
	Design	Procure	Install/ Construct	Design	Procure		Install / Construct
Corridor Communications Conduits	P	P	P	C	N	S	DB to provide branch conduit to the TxDOT duct bank system, including all that is necessary to furnish and install conduit, ground boxes, and terminations
Corridor to Traffic and Incident Management (TIM) Center	N	N	N	P	P	P	SI to provide Fault Tolerant IP-Based Communication System to the TIM for toll and ITS systems.
Data/Communications Service to each Tolling Location	N	N	S	P	P	P	SI to provide system design plans indicating power and communications/data requirements. SI to install any power and communications cable required to interface between the toll cabinet and the communications service provider's POI. DB is responsible for the conduit infrastructure to provide a raceway from the toll pad to the service POI.
SYSTEMS SERVERS AND SPACE							
Systems Servers and Workstations	N	N	C	P	P	P	SI to provide, install and configure all system servers and workstations required at the TIM Center to support the operations and management of the Express Lanes.
Federal Communication Commission License Preparation and Submission	C	N	N	P	P	P	SI to provide all information necessary to acquire FCC Licensing to the Mobility Authority.
DUCT BANK AND MOBILITY AUTHORITY INTELLIGENT TRANSPORTATION SYSTEMS (ITS)							
New Duct bank	P	P	P	C	C	C	SI to provide requirements for new duct bank. DB to incorporate design requirements for duct back/conduit backbone and laterals into Design Packages. DB to coordinate with SI to review and approve all versions of design packages.
Fiber Installation	N	N	C	P	P	P	SI to provide, install and test the fiber for toll and ITS systems owned by the Mobility Authority.

Primary Responsibility: P	Support Responsibility: S		Coordination Responsibility Only: C			No Responsibility: N	
Element/Task/Component/ Sub-system	DB Contractor (DB)		System Integrator (SI)			Comments Other Responsibility/Information	
	Design	Procure	Install/ Construct	Design	Procure		
DUCT BANK & INTELLIGENT TRANSPORTATION SYSTEMS (ITS) – TXDOT OWNED							
Duct Bank Adjustment and IT relocations design	P	P	P	N	N	N	DB is responsible for the design, relocation and replacement of existing TxDOT-owned ITS including, foundations, conduits, electrical services, grounding circuits, and support structures. DB responsible for adjusting existing duct bank junction/ground boxes and providing new junction/ground boxes. Coordination with TxDOT will be required.
Duct Bank Adjustments/new connections	P	P	P	S	N	C	DB is responsible for all adjustments and new junction/ground box ties.
Fiber optic cables	P	P	P	N	N	N	Any adjustments to and replacement of existing cables are DB responsibility. Testing of TxDOT-owned ITS is the DB's responsibility.
New or Replacement CCTV cameras, communications and equipment enclosures	P	P	P	S	N	C	DB to procure, install and terminate TxDOT-owned CCTV equipment, including cameras, camera controls, cables (power and communications), and connections compatible with TxDOT's Lonestar system. DB Contractor shall provide all the equipment necessary for TxDOT's control of all CCTV cameras. The method of control shall be in accordance with TxDOT Engineering Standard Sheets and TxDOT Standard Specifications. DB shall also be responsible for testing TxDOT-owned CCTV camera systems.
Relocation of existing CCTV and DMS foundations, conduits, grounding, camera poles, and electrical services	P	P	P	C	N	C	DB is responsible for relocating any existing CCTV and DMS structures and electrical services impacted by the Project Design, including communications and power. Damaged or inoperable equipment shall be removed, but not repaired. DB shall coordinate with TxDOT regarding proper storage of existing devices until time of reinstall.
Existing and new vehicle detector foundations, conduits, grounding, vehicle detector support	P	P	P	N	N	N	DB shall abandon any existing vehicle detectors/loops within the pavement within the Project limits.

Primary Responsibility: P	Support Responsibility: S		Coordination Responsibility Only: C			No Responsibility: N	
Element/Task/Component/ Sub-system	DB Contractor (DB)			System Integrator (SI)			Comments Other Responsibility/Information
	Design	Procure	Install/ Construct	Design	Procure	Install / Construct	
structures, and electrical services							
Vehicle detectors, communications, and equipment enclosures	P	P	P	C	N	C	DB is responsible for the procurement, installation and placement of new vehicle detectors. DB to coordinate with TxDOT regarding the placement of the detectors. DB shall provide power and communications to the vehicle detection equipment. DB to incorporate design requirements for vehicle detectors into Design Packages. DB to coordinate with Mobility Authority and TxDOT to review all versions of design packages.
Maintenance of ITS During Construction	P	P	P	C	N	C	<p>DB responsible for maintaining, restoring and protecting any existing ITS functionality, including those owned by TxDOT or local Governmental Entities, on the Project until Final Acceptance except during system maintenance, crossovers, or other periods approved by the Mobility Authority. For existing ITS impacted by the Project, DB required to develop and submit an ITS Implementation Plan as a part of the Intermediate (65%) Design Submittal outlining the interim and final locations of all communications infrastructure and field devices on the Project. DB responsible for procuring, installing and testing temporary wireless radio connections to maintain communications links for all existing TxDOT-owned ITS during construction.</p> <p>During construction of the Project, DB responsible for the repair of each existing communication cable, downed communications link, or electrical conductor that is severed or otherwise rendered not usable within:</p> <ul style="list-style-type: none"> • 4 hours if a major/backbone/trunk line. • 8 hours if a minor/drop fiber line.
Communications Network	P	P	P	C	N	C	For TxDOT communications infrastructure on the Project, DB is responsible for providing a communications network that has redundant routing capabilities. The communications network shall serve the highway ITS components along the highway Elements of the Project. Where necessary, as determined by TxDOT, DB shall provide ITS

Primary Responsibility: P	Support Responsibility: S		Coordination Responsibility Only: C			No Responsibility: N	
Element/Task/Component/ Sub-system	DB Contractor (DB)			System Integrator (SI)			Comments Other Responsibility/Information
	Design	Procure	Install/ Construct	Design	Procure	Install / Construct	
							communications hubs/cabinets to support the communications network. DB shall provide all the equipment necessary for the TxDOT communications network.
Testing relocated ITS equipment	P	P	P	C	N	C	DB is responsible for all system testing (e.g. acceptance and end-to-end testing) for new, replacement or relocated TxDOT-owned ITS equipment along the corridor. DB is responsible for coordinating testing with the Mobility Authority to ensure that there will be no conflicts between the Mobility Authority, TxDOT, their affiliated contractors, and DB Contractor's staff. DB is responsible for maintenance of traffic and traffic control during system testing.

Central Texas Regional Mobility Authority

Technical Provisions

For

183 North Mobility Project

ATTACHMENT 21-2

TOLL SYSTEM INSTALLATION DEPENDENCY MATRIX

System Integrator (SI)	Contractor (Infrastructure Activity)														Roadway Conditions
	Power Drops				Conduit Laterals (COMM)				Structures						Ductbank
Corridor Activity Item #	MDV Poles	CCTV Poles	OSB	DMS Structure	MVD Poles	CCTV Poles	OSB w/Device	DMS Structure	MDV Poles	CCTV Poles	OSB/COSS (ALL)	OSB w/Device	DMS Structure		
Verify Conduit per Plans					X	X	X	X						X	
Install MVD	X	X	X	X					X	X		X	X		
Install CCTV		X	X							X		X			
Install DMS				X				X					X		
Install Equipment Cabinet	X	X	X		X	X	X		X	X		X			
Install Fiber Trunk											X			X	
Install Fiber Laterals					X	X	X	X	X	X		X	X	X	
Install Underground Splice Enclosures					X	X	X	X	X	X		X	X	X	
Install Fiber Interconnect Cabinet/Pad														X	
Site Test	X	X	X	X	X	X	X	X	X	X		X	X		
Sensor Calibration															X
Field Network Test	X	X	X	X	X	X	X	X	X	X		X	X	X	
System OFIT/Commissioning Testing (2)	X	X	X	X	X	X	X	X	X	X		X	X	X	

Notes:

- (1) All of the Infrastructure items denoted with an X must be completed for SI Corridor Activity to Begin
- (2) Applies to a collection of Sites (Preferable All Sites)

Tolling Installation Dependency Matrix

System Integrator (SI)	Contractor (Infrastructure Activity)							
Tolling Activity Item #	Loop Stub-Outs	PFC Overlay (2)	Toll Pad(s)	Toll Gantry Structures	Gantry Conduit(s) to Pad	Lane Striping (3)	Service (Power Available @ Pad)	Ductbank
Verify Loop Stub-ups	X							
Install Loops (2)	X			X		X		
Verify Pad Stub-ups			X					
Install Pad Cabinet(s)			X					
Install Fiber Patch Panel			X					X
Install Toll Hanger				X		X		
Install Toll Devices (Gantry/Hanger)				X	X	X	X	
Install Field Cable (Terminate/Test)			X	X	X		X	
Install Equipment Panels/Servers/Network			X				X	
Leased Comm. Link (5)			X				X	X
Site Test	X	X	X	X	X	X	X	X
Field Network Test	X		X	X	X	X	X	X
System OFIT/Commissioning Testing (4)	X	X	X	X	X	X	X	X

Notes:

- (1) All of the Infrastructure items denoted with an X must be completed for Tolling Activity to Begin
- (2) Saw Cut and wrapping of loops MUST be done prior to application PFC Layer in the toll zone.
- (3) Lane Striping does not have to be permanent striping but must be laid out in permanent lane configuration
- (4) Applies to a collection of Sites (Preferable All Sites)
- (5) Leased Line may utilize Corridor Trunk Fiber (An SI dependency)

EXHIBIT D

REFERENCE DOCUMENTS

FOR

DEVELOPMENT OF THE

183 NORTH MOBILITY PROJECT

THROUGH A DESIGN-BUILD AGREEMENT

PROJECT NUMBER: 20183N22701C



BY THE

CENTRAL TEXAS REGIONAL MOBILITY AUTHORITY

EXECUTION COPY

Reference Documents

All files posted within the folders and sub-folders listed below and included in the RID INDEX are included in this Exhibit D – Reference Documents.

Item	Description	
Item 1.0	General	
1.1	Texas Transportation Commission Minute Order	
1.2	Construction Quality Assurance Program (QAP)	
1.3	DB Minimum Sampling and Testing Guide Schedule	
1.4	Project Development Agreement (PDA)	
1.5	Community Relations Program Plan	
1.6	Limits of Maintenance	
Item 2.0	Environmental	
2.1	Environmental Assessment Reports	
	2.1.1	Air
	2.1.2	Biology
	2.1.3	Community Impact Assessment
	2.1.4	Cultural Resources
	2.1.5	General
	2.1.6	Geological Assessment
	2.1.7	HazMat
	2.1.8	ICI
	2.1.9	Noise
	2.1.10	Project (NEPA docs)
	2.1.11	Public Involvement
	2.1.12	Water
2.2	Environmental Assessment FONSI	
2.3	Biological Assessment	
2.4	Environmental Reevaluation	
2.5	Biological Opinion	
Item 3.0	Technical	
3.1	As-Builts	
	3.1.1	TxDOT Plans
	3.1.2	MoPac Improvement Project As-Builts

Item	Description	
	3.1.3	Drainage Site Plans
	3.1.4	ITS As-Builts
3.2	Base Files	
	3.2.1	Final Schematic Base Files
	3.2.2	Ultimate Schematic Base Files
	3.2.3	Deferred Work Base Files
3.3	Design Reports	
	3.3.1	Design Calculations
	3.3.2	Design Exceptions
3.4	Drainage	
	3.4.1	Lake Creek Watershed Analysis
	3.4.2	Rattan Creek Watershed Analysis
	3.4.3	Walnut Creek Watershed Analysis
	3.4.4	Shoal Creek Watershed Analysis
	3.4.5	EA WQ TCEQ Calcs
	3.4.6	Post EA WQ Hydraulic Toolbox for Water Quality Ponds
	3.4.7	Drainage WPAPs Historical Files
	3.4.8	2015 MIP Drainage Report
	3.4.9	183 N TxDOT Preliminary DRN and WQ Impact Memo
	3.4.10	Onsite Impact Assessment Evaluation Memo
	3.4.11	Offsite Impact Assessment Evaluation Memo
	3.4.12	TSS BA Memo
	3.4.13	Project Segmentation and Phasing Approach for TCEQ EAPP WPAP Applications
	3.4.14	City of Austin GIS Flood Data
3.5	Existing Topo Information	
	3.5.1	2013
	3.5.2	2019
	3.5.3	Aerial
3.6	Geotechnical	
3.7	Roadway	
	3.7.1	Schematic Plans
	3.7.2	Austin District Standards
	3.7.3	Driveway Exhibits
3.8	Structural	
	3.8.1	Bridge Layouts
	3.8.2	Lead and Asbestos Reports
	3.8.3	Bridge Inspection Reports
3.9	Aesthetic Design Guide from Previous Projects	

Item	Description	
3.10	Pavement	
	3.10.1	Pavement Design Report
	3.10.2	Existing Pavement Ride Quality Analysis
3.11	ITS	
	3.11.1	ITS Concept of Operations
	3.11.2	ITS Schematic
	3.11.3	ITS Concept Document
3.12	Tolling	
	3.12.1	Fixed Price Tolling Standards
	3.12.2	Concrete Paving Standards at Toll Gantry Locations
Item 4.0		
Utilities		
4.1	Existing Utility Information	
4.2	SUE Files	
	4.2.1	2018 SUE Files (QLD)
	4.2.2	2019 SUE Files (QLB)
4.3	Standard Utility Forms	
4.4	Austin Water Standards and Practices Manual for 183 North Mobility Project	
4.5	Approved Utility Permits	
4.6	City of Austin water and wastewater conflict exhibits	
Item 5.0		
Right of Way		
Item 6.0		
Survey Data		
Item 7.0		
Agreements		
7.1	Traffic Signal Maintenance Letter Agreement	
Item 8.0		
Traffic		
8.1	Traffic Data	
	8.1.1	Existing Volumes
	8.1.2	Existing Models
	8.1.3	Forecast Volumes
	8.1.4	Forecast Models
8.2	Oregon Department of Transportation's Protocol for VISSIM Simulation	

EXHIBITS E through P

FOR

DEVELOPMENT OF THE

183 NORTH MOBILITY PROJECT

THROUGH A DESIGN-BUILD AGREEMENT

PROJECT NUMBER: 20183N22701C



BY THE

CENTRAL TEXAS REGIONAL MOBILITY AUTHORITY

EXECUTION COPY

EXHIBIT E
FEDERAL REQUIREMENTS

<u>Exhibit Description</u>	<u>No. of Pages</u>
Attachment 1 – Federal Requirements for Federal-Aid Construction Facilities	4
Attachment 2 – Required Contract Provisions Federal-Aid Construction Contracts, FHWA Form 1273	19
Attachment 3 – Federal Prevailing Wage Rate	3
Attachment 4 – Equal Employment Opportunity	5
Attachment 5 – Affirmative Action	5
Attachment 6 – Debarment and Suspension Certification	1
Attachment 7 – Certification Regarding use of Contract Funds for Lobbying	1
Attachment 8 – Compliance with Buy America Requirements	2
Attachment 9 – Notice to All Bidders	1
Attachment 10 – Certification of Nondiscrimination in Employment	1
Attachment 11 – On-the-Job Training Program	1

ATTACHMENT 1 TO EXHIBIT E

FEDERAL REQUIREMENTS FOR FEDERAL-AID CONSTRUCTION FACILITIES

GENERAL. — The work herein proposed will be financed in whole or in part with Federal funds, and therefore all of the statutes, rules and regulations promulgated by the Federal Government and applicable to work financed in whole or in part with Federal funds will apply to such work. The "Required Contract Provisions, Federal-Aid Construction Contracts, Form FHWA 1273," are included in this Exhibit E. Whenever in said required DB Agreement provisions references are made to:

(a) "SHA contracting officer", "SHA resident engineer", or "authorized representative of the SHA", such references shall be construed to mean the Texas Department of Transportation (TxDOT) or its Authorized Representative;

(b) "contractor", "prime contractor", "bidder" or "prospective primary participant", such references shall be construed to mean the DB Contractor or its authorized representative;

(c) "contract" or "prime contract", such references shall be construed to mean the DB Agreement;

(d) "subcontractor", "supplier", "vendor", "prospective lower tier participant" or "lower tier subcontractor", such references shall be construed to mean, as appropriate, Contractors other than the DB Contractor; and

(e) "department", "agency" or "department or agency entering into this transaction", such references shall be construed to mean TxDOT or its Authorized Representative, except where a different department or agency is specified.

PERFORMANCE OF PREVIOUS CONTRACT. — In addition to the provisions in Section II, "Nondiscrimination," and Section VII, "Subletting or Assigning the Contract," of the Form 1273 required contract provisions, the DB Contractor shall cause the contractor to comply with the following:

The bidder shall execute the CERTIFICATION WITH REGARD TO THE PERFORMANCE OF PREVIOUS CONTRACTS OR SUBCONTRACTS SUBJECT TO THE EQUAL OPPORTUNITY CLAUSE AND THE FILING OF REQUIRED REPORTS located in the proposal. No request for subletting or assigning any portion of the contract in excess of \$10,000 will be considered under the provisions of Section VII of the required contract provisions unless such request is accompanied by the CERTIFICATION referred to above, executed by the proposed subcontractor.

NON-COLLUSION PROVISION. — The provisions in this section are applicable to all contracts except contracts for Federal Aid Secondary Projects. Title 23, United States Code, Section 112, requires as a condition precedent to approval by the Federal Highway Administrator of the contract for this work that each bidder file a sworn statement executed by, or on behalf of, the person, firm, association, or corporation to whom such contract is to be awarded, certifying that such person, firm, association, or corporation has not, either directly or indirectly, entered into any agreement, participated in any collusion, or otherwise taken any action in restraint of free

competitive bidding in connection with the submitted bid. A form to make the non-collusion affidavit statement required by Section 112 as a certification under penalty of perjury rather than as a sworn statement as permitted by 28 U.S.C., Sec. 1746, is included in the Proposal.

PARTICIPATION BY DISADVANTAGED BUSINESS ENTERPRISES IN SUBCONTRACTING. — Part 26, Title 49, Code of Federal Regulations applies to the Project. Pertinent sections of said Code are incorporated within other sections of the DB Agreement and the TxDOT Disadvantaged Business Enterprise Program adopted pursuant to 49 CFR Part 26.

CONVICT PRODUCED MATERIALS

a. FHWA Federal-aid projects are subject to 23 CFR § 635.417, Convict produced materials.

b. Materials produced after July 1, 1991, by convict labor may only be incorporated in a Federal aid highway construction project if such materials have been: (i) produced by convicts who are on parole, supervised release, or probation from a prison, or (ii) produced in a prison project in which convicts, during the 12 month period ending July 1, 1987, produced materials for use in Federal aid highway construction projects, and the cumulative annual production amount of such materials for use in Federal aid highway construction does not exceed the amount of such materials produced in such project for use in Federal aid highway construction during the 12 month period ending July 1, 1987.

FHWA FORM 1273 SECTIONS VII.1 AND VII.2 INAPPLICABLE – Pursuant to 23 CFR 635.116(d), the requirements of Sections VII.1 and VII.2 of FHWA Form 1273 (Attachment 2 to Exhibit 8 to the Agreement) are inapplicable to the Agreement.

ACCESS TO RECORDS

a. As required by 49 CFR 18.36(i)(10), the DB Contractor and its Contractors shall allow FHWA and the Comptroller General of the United States, or their duly authorized representatives, access to all books, documents, papers, and records of the DB Contractor and Contractors which are directly pertinent to any grantee or subgrantee contract, for the purpose of making audit, examination, excerpts, and transcriptions thereof. In addition, as required by 49 CFR 18.36(i)(11), the DB Contractor and its Contractors shall retain all such books, documents, papers, and records for three years after final payment is made pursuant to any such contract and all other pending matters are closed.

b. The DB Contractor agrees to include this section in each Contract at each tier, without modification except as appropriate to identify the Contractor who will be subject to its provisions.

USE OF UNITED STATES-FLAG VESSELS

a. The DB Contractor shall comply with the requirements of 46 CFR Part 381 whenever transporting by oceanic shipment any equipment, material, or commodities acquired solely for the Project, and not to replenish existing inventories independent of the Design-Build Contract.

b. For such shipments, the DB Contractor agrees:

(i) To utilize privately owned United States-flag commercial vessels to ship at least 50 percent of the gross tonnage (computed separately for dry bulk carriers, dry cargo liners, and tankers) involved, whenever shipping any equipment, material, or commodities pursuant to this Agreement, to the extent such vessels are available at fair and reasonable rates for United States-flag commercial vessels; and

(ii) To furnish within 20 days following the date of loading for shipments originating within the United States or within 30 working days following the date of loading for shipments originating outside the United States, a legible copy of a rated, "on-board" commercial ocean bill-of-lading in English for each shipment of cargo described in paragraph (i) of this section to both TxDOT (through the DB Contractor in the case of subcontractor bills-of-lading) and to the Division of National Cargo, Office of Market Development, Maritime Administration, Washington, DC 20590.

c. The DB Contractor shall insert the substance of this provision in all Subcontracts.

NONDISCRIMINATION AUTHORITIES

During the performance of this contract, the DB Contractor, for itself, its assignees, and successors in interest (hereinafter referred to as the "contractor") agrees to comply with the following nondiscrimination statutes and authorities; including but not limited to:

Pertinent Nondiscrimination Authorities:

· Title VI of the Civil Rights Act of 1964 (42 U.S.C. § 2000d et seq., 78 stat. 252), (prohibits discrimination on the basis of race, color, national origin); and 49 CFR Part 21.

· The Uniform Relocation Assistance and Real Property Acquisition Policies Act of 1970, (42 U.S.C. § 4601), (prohibits unfair treatment of persons displaced or whose property has been acquired because of Federal or Federal-aid programs and projects);

· Federal-Aid Highway Act of 1973, (23 U.S.C. § 324 et seq.), (prohibits discrimination on the basis of sex);

· Section 504 of the Rehabilitation Act of 1973, (29 U.S.C. § 794 et seq.), as amended, (prohibits discrimination on the basis of disability); and 49 CFR Part 27;

· The Age Discrimination Act of 1975, as amended, (42 U.S.C. § 6101 et seq.), (prohibits discrimination on the basis of age);

· Airport and Airway Improvement Act of 1982. (49 U.S.C. § 4 71, Section 4 7123), as amended, (prohibits discrimination based on race, creed, color, national origin, or sex);

· The Civil Rights Restoration Act of 1987, (PL 100-209), (Broadened the scope, coverage and applicability of Title VI of the Civil Rights Act of 1964, The Age Discrimination Act of 1975 and Section 504 of the Rehabilitation Act of 1973, by expanding the definition of the terms "programs or activities" to include all of the programs or activities of the Federal-aid recipients, subrecipients and contractors, whether such programs or activities are Federally funded or not);

- Titles II and III of the Americans with Disabilities Act, which prohibit discrimination on the basis of disability in the operation of public entities, public and private transportation systems, places of public accommodation, and certain testing entities (42 U.S.C. §§ 12131-12189) as implemented by Department of Transportation regulations at 49 C.F.R. parts 37 and 38;

- The Federal Aviation Administration's Nondiscrimination statute (49 U.S.C. § 47123) (prohibits discrimination on the basis of race, color, national origin, and sex);

- Executive Order 12898, Federal Actions to Address Environmental Justice in Minority Populations and Low-Income Populations, which ensures discrimination against minority populations by discouraging programs, policies, and activities with disproportionately high and adverse human health or environmental effects on minority and low-income populations;

- Executive Order 13166, Improving Access to Services for Persons with Limited English Proficiency, and resulting agency guidance, national origin discrimination includes discrimination because of limited English proficiency (LEP). To ensure compliance with Title VI, you must take reasonable steps to ensure that LEP persons have meaningful access to your programs (70 Fed. Reg. at 74087 to 74100);

- Title IX of the Education Amendments 011972, as amended, which prohibits you from discriminating because of sex in education programs or activities (20 U .S.C. 1681 et seq).

RECOVERED MATERIALS

DB Contractor shall comply with all requirements of section 6002 of the Solid Waste Disposal Act, as amended by the Resource Conservation and Recovery Act (RCRA), including the regulatory provisions of 40 CFR Part 247, and Executive Order 12873, as they apply to the procurement of the items designated in Subpart B of 40 CFR Part 247.

ATTACHMENT 2 TO EXHIBIT E
REQUIRED CONTRACT PROVISIONS
FEDERAL-AID CONSTRUCTION CONTRACTS
FHWA Form 1273

TABLE OF CONTENTS

FHWA-1273 -- Revised May 1, 2012

REQUIRED CONTRACT PROVISIONS
FEDERAL-AID CONSTRUCTION CONTRACTS

- I. General
- II. Nondiscrimination
- III. Nonsegregated Facilities
- IV. Davis-Bacon and Related Act Provisions
- V. Contract Work Hours and Safety Standards Act Provisions
- VI. Subletting or Assigning the Contract
- VII. Safety: Accident Prevention
- VIII. False Statements Concerning Highway Projects
- IX. Implementation of Clean Air Act and Federal Water Pollution Control Act
- X. Compliance with Governmentwide Suspension and Debarment Requirements
- XI. Certification Regarding Use of Contract Funds for Lobbying

ITEMS

A. Employment and Materials Preference for Appalachian Development Highway System or Appalachian Local Access Road Contracts (included in Appalachian contracts only)

I. GENERAL

1. Form FHWA-1273 must be physically incorporated in each construction contract funded under Title 23 (excluding emergency contracts solely intended for debris removal). The contractor (or subcontractor) must insert this form in each subcontract and further require its inclusion in all lower tier subcontracts (excluding purchase orders, rental agreements and other agreements for supplies or services).

The applicable requirements of Form FHWA-1273 are incorporated by reference for work done under any purchase order, rental agreement or agreement for other services. The prime contractor shall be responsible for compliance by any subcontractor, lower-tier subcontractor or service provider.

Form FHWA-1273 must be included in all Federal-aid design-build contracts, in all subcontracts and in lower tier subcontracts (excluding subcontracts for design services, purchase orders, rental agreements and other agreements for supplies or services). The design-builder shall be responsible for compliance by any subcontractor, lower-tier subcontractor or service provider.

Contracting agencies may reference Form FHWA-1273 in bid proposal or request for proposal documents, however, the Form FHWA-1273 must be physically incorporated (not referenced) in all contracts, subcontracts and lower-tier subcontracts (excluding purchase orders, rental agreements and other agreements for supplies or services related to a construction contract).

2. Subject to the applicability criteria noted in the following sections, these contract provisions shall apply to all work performed on the contract by the contractor's own organization and with the assistance of workers under the contractor's immediate superintendence and to all work performed on the contract by piecework, station work, or by subcontract.

3. A breach of any of the stipulations contained in these Required Contract Provisions may be sufficient grounds for withholding of progress payments, withholding of final payment, termination of the contract, suspension / debarment or any other action determined to be appropriate by the contracting agency and FHWA.

4. Selection of Labor: During the performance of this contract, the contractor shall not use convict labor for any purpose within the limits of a construction project on a Federal-aid highway unless it is labor performed by convicts who are on parole, supervised release, or probation. The term Federal-aid highway does not include roadways functionally classified as local roads or rural minor collectors.

II. NONDISCRIMINATION

The provisions of this section related to 23 CFR Part 230 are applicable to all Federal-aid construction contracts and to all related construction subcontracts of \$10,000 or more. The provisions of 23 CFR Part 230 are not applicable to material supply, engineering, or architectural service contracts.

In addition, the contractor and all subcontractors must comply with the following policies: Executive Order 11246, 41 CFR 60, 29 CFR 1625-1627, Title 23 USC Section 140, the Rehabilitation Act of 1973, as amended (29 USC 794), Title VI of the Civil Rights Act of 1964, as amended, and related regulations including 49 CFR Parts 21, 26 and 27; and 23 CFR Parts 200, 230, and 633.

The contractor and all subcontractors must comply with: the requirements of the Equal Opportunity Clause in 41 CFR 60-1.4(b) and, for all construction contracts exceeding \$10,000, the Standard Federal Equal Employment Opportunity Construction Contract Specifications in 41 CFR 60-4.3.

Note: The U.S. Department of Labor has exclusive authority to determine compliance with Executive Order 11246 and the policies of the Secretary of Labor including 41 CFR 60, and 29 CFR 1625-1627. The contracting agency and the FHWA have the authority and the responsibility to ensure compliance with Title 23 USC Section 140, the Rehabilitation Act of 1973, as amended (29 USC 794), and Title VI of the Civil Rights Act of 1964, as amended, and related regulations including 49 CFR Parts 21, 26 and 27; and 23 CFR Parts 200, 230, and 633.

The following provision is adopted from 23 CFR 230, Appendix A, with appropriate revisions to conform to the U.S. Department of Labor (US DOL) and FHWA requirements.

1. Equal Employment Opportunity: Equal employment opportunity (EEO) requirements not to discriminate and to take affirmative action to assure equal opportunity as set forth under laws, executive orders, rules, regulations (28 CFR 35, 29 CFR 1630, 29 CFR 1625-1627, 41 CFR 60 and 49 CFR 27) and orders of the Secretary of Labor as modified by the provisions prescribed herein, and imposed pursuant to 23 U.S.C. 140 shall constitute the EEO and specific affirmative action standards for the contractor's project activities under this contract. The provisions of the Americans with Disabilities Act of 1990 (42 U.S.C. 12101 et seq.) set forth under 28 CFR 35 and 29 CFR 1630 are incorporated by reference in this contract. In the execution of this contract, the contractor agrees to comply with the following minimum specific requirement activities of EEO:

a. The contractor will work with the contracting agency and the Federal Government to ensure that it has made every good faith effort to provide equal opportunity with respect to all of its terms and conditions of employment and in their review of activities under the contract.

b. The contractor will accept as its operating policy the following statement:

"It is the policy of this Company to assure that applicants are employed, and that employees are treated during employment, without regard to their race, religion, sex, color, national origin, age or disability. Such action shall include: employment, upgrading, demotion, or transfer; recruitment or recruitment advertising; layoff or termination; rates of pay or other forms of compensation; and selection for training, including apprenticeship, pre-apprenticeship, and/or on-the-job training."

2. EEO Officer: The contractor will designate and make known to the contracting officers an EEO Officer who will have the responsibility for and must be capable of effectively administering and promoting an active EEO program and who must be assigned adequate authority and responsibility to do so.

3. Dissemination of Policy: All members of the contractor's staff who are authorized to hire, supervise, promote, and discharge employees, or who recommend such action, or who are substantially involved in such action, will be made fully cognizant of, and will implement, the contractor's EEO policy and contractual responsibilities to provide EEO in each grade and classification of employment. To ensure that the above agreement will be met, the following actions will be taken as a minimum:

a. Periodic meetings of supervisory and personnel office employees will be conducted before the start of work and then not less often than once every six months, at which time the contractor's EEO policy and its implementation will be reviewed and explained. The meetings will be conducted by the EEO Officer.

b. All new supervisory or personnel office employees will be given a thorough indoctrination by the EEO Officer, covering all major aspects of the contractor's EEO obligations within thirty days following their reporting for duty with the contractor.

c. All personnel who are engaged in direct recruitment for the project will be instructed by the EEO Officer in the contractor's procedures for locating and hiring minorities and women.

d. Notices and posters setting forth the contractor's EEO policy will be placed in areas readily accessible to employees, applicants for employment and potential employees.

e. The contractor's EEO policy and the procedures to implement such policy will be brought to the attention of employees by means of meetings, employee handbooks, or other appropriate means.

4. Recruitment: When advertising for employees, the contractor will include in all advertisements for employees the notation: "An Equal Opportunity Employer." All such advertisements will be placed in publications having a large circulation among minorities and women in the area from which the project work force would normally be derived.

a. The contractor will, unless precluded by a valid bargaining agreement, conduct systematic and direct recruitment through public and private employee referral sources likely to yield qualified minorities and women. To meet this requirement, the contractor will identify sources of potential minority group employees, and establish with such identified sources procedures whereby minority and women applicants may be referred to the contractor for employment consideration.

b. In the event the contractor has a valid bargaining agreement providing for exclusive hiring hall referrals, the contractor is expected to observe the provisions of that agreement to the extent that the system meets the contractor's compliance with EEO contract provisions. Where implementation of such an agreement has the effect of discriminating against minorities or women, or obligates the contractor to do the same, such implementation violates Federal nondiscrimination provisions.

c. The contractor will encourage its present employees to refer minorities and women as applicants for employment. Information and procedures with regard to referring such applicants will be discussed with employees.

5. Personnel Actions: Wages, working conditions, and employee benefits shall be established and administered, and personnel actions of every type, including hiring, upgrading, promotion, transfer, demotion, layoff, and termination, shall be taken without regard to race, color, religion, sex, national origin, age or disability. The following procedures shall be followed:

a. The contractor will conduct periodic inspections of project sites to insure that working conditions and employee facilities do not indicate discriminatory treatment of project site personnel.

b. The contractor will periodically evaluate the spread of wages paid within each classification to determine any evidence of discriminatory wage practices.

c. The contractor will periodically review selected personnel actions in depth to determine whether there is evidence of discrimination. Where evidence is found, the contractor will promptly take corrective action. If the review indicates that the discrimination may extend beyond the actions reviewed, such corrective action shall include all affected persons.

d. The contractor will promptly investigate all complaints of alleged discrimination made to the contractor in connection with its obligations under this contract, will attempt to resolve such complaints, and will take appropriate corrective action within a reasonable time. If the investigation indicates that the discrimination may affect persons other than the complainant, such corrective action shall include such other persons. Upon completion of each investigation, the contractor will inform every complainant of all of their avenues of appeal.

6. Training and Promotion:

a. The contractor will assist in locating, qualifying, and increasing the skills of minorities and women who are applicants for employment or current employees. Such efforts should be aimed at developing full journey level status employees in the type of trade or job classification involved.

b. Consistent with the contractor's work force requirements and as permissible under Federal and State regulations, the contractor shall make full use of training programs, i.e., apprenticeship, and on-the-job training programs for the geographical area of contract performance. In the event a special provision for training is provided under this contract, this subparagraph will be superseded as indicated in the special provision. The contracting agency may reserve training positions for persons who receive welfare assistance in accordance with 23 U.S.C. 140(a).

c. The contractor will advise employees and applicants for employment of available training programs and entrance requirements for each.

d. The contractor will periodically review the training and promotion potential of employees who are minorities and women and will encourage eligible employees to apply for such training and promotion.

7. Unions: If the contractor relies in whole or in part upon unions as a source of employees, the contractor will use good faith efforts to obtain the cooperation of such unions to increase opportunities for minorities and women. Actions by the contractor, either directly or through a contractor's association acting as agent, will include the procedures set forth below:

a. The contractor will use good faith efforts to develop, in cooperation with the unions, joint training programs aimed toward qualifying more minorities and women for membership in the unions and increasing the skills of minorities and women so that they may qualify for higher paying employment.

b. The contractor will use good faith efforts to incorporate an EEO clause into each union agreement to the end that such union will be contractually bound to refer applicants without regard to their race, color, religion, sex, national origin, age or disability.

c. The contractor is to obtain information as to the referral practices and policies of the labor union except that to the extent such information is within the exclusive possession of the labor union and such labor union refuses to furnish such information to the contractor, the contractor shall so certify to the contracting agency and shall set forth what efforts have been made to obtain such information.

d. In the event the union is unable to provide the contractor with a reasonable flow of referrals within the time limit set forth in the collective bargaining agreement, the contractor will, through independent recruitment efforts, fill the employment vacancies without regard to race, color, religion, sex, national origin, age or disability; making full efforts to obtain qualified and/or qualifiable minorities and women. The failure of a union to provide sufficient referrals (even though it is obligated to provide exclusive referrals under the terms of a collective bargaining agreement) does not relieve the contractor from the requirements of this paragraph. In the event the union referral practice prevents the contractor from meeting the obligations pursuant to Executive Order 11246, as amended, and these special provisions, such contractor shall immediately notify the contracting agency.

8. Reasonable Accommodation for Applicants / Employees with Disabilities: The contractor must be familiar with the requirements for and comply with the Americans with Disabilities Act and all rules and regulations established there under. Employers must provide reasonable accommodation in all employment activities unless to do so would cause an undue hardship.

9. Selection of Subcontractors, Procurement of Materials and Leasing of Equipment: The contractor shall not discriminate on the grounds of race, color, religion, sex, national origin, age or disability in the selection and retention of subcontractors, including procurement of materials and leases of equipment. The contractor shall take all necessary and reasonable steps to ensure nondiscrimination in the administration of this contract.

a. The contractor shall notify all potential subcontractors and suppliers and lessors of their EEO obligations under this contract.

b. The contractor will use good faith efforts to ensure subcontractor compliance with their EEO obligations.

10. Assurance Required by 49 CFR 26.13(b):

a. The requirements of 49 CFR Part 26 and the State DOT's U.S. DOT-approved DBE program are incorporated by reference.

b. The contractor or subcontractor shall not discriminate on the basis of race, color, national origin, or sex in the performance of this contract. The contractor shall carry out applicable requirements of 49 CFR Part 26 in the award and administration of DOT-assisted contracts. Failure by the contractor to carry out these requirements is a material breach of this contract, which may result in the termination of this contract or such other remedy as the contracting agency deems appropriate.

11. Records and Reports: The contractor shall keep such records as necessary to document compliance with the EEO requirements. Such records shall be retained for a period of three years following the date of the final payment to the contractor for all contract work and shall be available at reasonable times and places for inspection by authorized representatives of the contracting agency and the FHWA.

a. The records kept by the contractor shall document the following:

(1) The number and work hours of minority and non-minority group members and women employed in each work classification on the project;

(2) The progress and efforts being made in cooperation with unions, when applicable, to increase employment opportunities for minorities and women; and

(3) The progress and efforts being made in locating, hiring, training, qualifying, and upgrading minorities and women;

b. The contractors and subcontractors will submit an annual report to the contracting agency each July for the duration of the project, indicating the number of minority, women, and non-minority group employees currently engaged in each work classification required by the contract work. This information is to be reported on Form FHWA-1391. The staffing data should represent the project work force on board in all or any part of the last payroll period preceding the end of July. If on-the-job training is being required by special provision, the contractor will be required to collect and report training data. The employment data should reflect the work force on board during all or any part of the last payroll period preceding the end of July.

III. NONSEGREGATED FACILITIES

This provision is applicable to all Federal-aid construction contracts and to all related construction subcontracts of \$10,000 or more.

The contractor must ensure that facilities provided for employees are provided in such a manner that segregation on the basis of race, color, religion, sex, or national origin cannot result. The contractor may neither require such segregated use by written or oral policies nor tolerate such use by employee custom. The contractor's obligation extends further to ensure that its employees are not assigned to perform their services at any location, under the contractor's control, where the facilities are segregated. The term "facilities" includes waiting rooms, work areas, restaurants and other eating areas, time clocks, restrooms, washrooms, locker rooms, and other storage or dressing areas, parking lots, drinking fountains, recreation or entertainment areas, transportation, and housing provided for employees. The contractor shall provide separate or single-user restrooms and necessary dressing or sleeping areas to assure privacy between sexes.

IV. DAVIS-BACON AND RELATED ACT PROVISIONS

This section is applicable to all Federal-aid construction projects exceeding \$2,000 and to all related subcontracts and lower-tier subcontracts (regardless of subcontract size). The requirements apply to all

projects located within the right-of-way of a roadway that is functionally classified as Federal-aid highway. This excludes roadways functionally classified as local roads or rural minor collectors, which are exempt. Contracting agencies may elect to apply these requirements to other projects.

The following provisions are from the U.S. Department of Labor regulations in 29 CFR 5.5 “Contract provisions and related matters” with minor revisions to conform to the FHWA-1273 format and FHWA program requirements.

1. Minimum wages

a. All laborers and mechanics employed or working upon the site of the work, will be paid unconditionally and not less often than once a week, and without subsequent deduction or rebate on any account (except such payroll deductions as are permitted by regulations issued by the Secretary of Labor under the Copeland Act (29 CFR part 3)), the full amount of wages and bona fide fringe benefits (or cash equivalents thereof) due at time of payment computed at rates not less than those contained in the wage determination of the Secretary of Labor which is attached hereto and made a part hereof, regardless of any contractual relationship which may be alleged to exist between the contractor and such laborers and mechanics.

Contributions made or costs reasonably anticipated for bona fide fringe benefits under section 1(b)(2) of the Davis-Bacon Act on behalf of laborers or mechanics are considered wages paid to such laborers or mechanics, subject to the provisions of paragraph 1.d. of this section; also, regular contributions made or costs incurred for more than a weekly period (but not less often than quarterly) under plans, funds, or programs which cover the particular weekly period, are deemed to be constructively made or incurred during such weekly period. Such laborers and mechanics shall be paid the appropriate wage rate and fringe benefits on the wage determination for the classification of work actually performed, without regard to skill, except as provided in 29 CFR 5.5(a)(4). Laborers or mechanics performing work in more than one classification may be compensated at the rate specified for each classification for the time actually worked therein: Provided, That the employer's payroll records accurately set forth the time spent in each classification in which work is performed. The wage determination (including any additional classification and wage rates conformed under paragraph 1.b. of this section) and the Davis-Bacon poster (WH-1321) shall be posted at all times by the contractor and its subcontractors at the site of the work in a prominent and accessible place where it can be easily seen by the workers.

b. (1) The contracting officer shall require that any class of laborers or mechanics, including helpers, which is not listed in the wage determination and which is to be employed under the contract shall be classified in conformance with the wage determination. The contracting officer shall approve an additional classification and wage rate and fringe benefits therefore only when the following criteria have been met:

(i) The work to be performed by the classification requested is not performed by a classification in the wage determination; and

(ii) The classification is utilized in the area by the construction industry; and

(iii) The proposed wage rate, including any bona fide fringe benefits, bears a reasonable relationship to the wage rates contained in the wage determination.

(2) If the contractor and the laborers and mechanics to be employed in the classification (if known), or their representatives, and the contracting officer agree on the classification and wage rate (including the amount designated for fringe benefits where appropriate), a report of the action taken shall be sent by the contracting officer to the Administrator of the Wage and Hour Division, Employment Standards

Administration, U.S. Department of Labor, Washington, DC 20210. The Administrator, or an authorized representative, will approve, modify, or disapprove every additional classification action within 30 days of receipt and so advise the contracting officer or will notify the contracting officer within the 30-day period that additional time is necessary.

(3) In the event the contractor, the laborers or mechanics to be employed in the classification or their representatives, and the contracting officer do not agree on the proposed classification and wage rate (including the amount designated for fringe benefits, where appropriate), the contracting officer shall refer the questions, including the views of all interested parties and the recommendation of the contracting officer, to the Wage and Hour Administrator for determination. The Wage and Hour Administrator, or an authorized representative, will issue a determination within 30 days of receipt and so advise the contracting officer or will notify the contracting officer within the 30-day period that additional time is necessary.

(4) The wage rate (including fringe benefits where appropriate) determined pursuant to paragraphs 1.b.(2) or 1.b.(3) of this section, shall be paid to all workers performing work in the classification under this contract from the first day on which work is performed in the classification.

c. Whenever the minimum wage rate prescribed in the contract for a class of laborers or mechanics includes a fringe benefit which is not expressed as an hourly rate, the contractor shall either pay the benefit as stated in the wage determination or shall pay another bona fide fringe benefit or an hourly cash equivalent thereof.

d. If the contractor does not make payments to a trustee or other third person, the contractor may consider as part of the wages of any laborer or mechanic the amount of any costs reasonably anticipated in providing bona fide fringe benefits under a plan or program, Provided, That the Secretary of Labor has found, upon the written request of the contractor, that the applicable standards of the Davis-Bacon Act have been met. The Secretary of Labor may require the contractor to set aside in a separate account assets for the meeting of obligations under the plan or program.

2. Withholding

The contracting agency shall upon its own action or upon written request of an authorized representative of the Department of Labor, withhold or cause to be withheld from the contractor under this contract, or any other Federal contract with the same prime contractor, or any other federally-assisted contract subject to Davis-Bacon prevailing wage requirements, which is held by the same prime contractor, so much of the accrued payments or advances as may be considered necessary to pay laborers and mechanics, including apprentices, trainees, and helpers, employed by the contractor or any subcontractor the full amount of wages required by the contract. In the event of failure to pay any laborer or mechanic, including any apprentice, trainee, or helper, employed or working on the site of the work, all or part of the wages required by the contract, the contracting agency may, after written notice to the contractor, take such action as may be necessary to cause the suspension of any further payment, advance, or guarantee of funds until such violations have ceased.

3. Payrolls and basic records

a. Payrolls and basic records relating thereto shall be maintained by the contractor during the course of the work and preserved for a period of three years thereafter for all laborers and mechanics working at the site of the work. Such records shall contain the name, address, and social security number of each such worker, his or her correct classification, hourly rates of wages paid (including rates of contributions or costs anticipated for bona fide fringe benefits or cash equivalents thereof of the types described in section 1(b)(2)(B) of the Davis-Bacon Act), daily and weekly number of hours worked, deductions made and actual

wages paid. Whenever the Secretary of Labor has found under 29 CFR 5.5(a)(1)(iv) that the wages of any laborer or mechanic include the amount of any costs reasonably anticipated in providing benefits under a plan or program described in section 1(b)(2)(B) of the Davis-Bacon Act, the contractor shall maintain records which show that the commitment to provide such benefits is enforceable, that the plan or program is financially responsible, and that the plan or program has been communicated in writing to the laborers or mechanics affected, and records which show the costs anticipated or the actual cost incurred in providing such benefits. Contractors employing apprentices or trainees under approved programs shall maintain written evidence of the registration of apprenticeship programs and certification of trainee programs, the registration of the apprentices and trainees, and the ratios and wage rates prescribed in the applicable programs.

b. (1) The contractor shall submit weekly for each week in which any contract work is performed a copy of all payrolls to the contracting agency. The payrolls submitted shall set out accurately and completely all of the information required to be maintained under 29 CFR 5.5(a)(3)(i), except that full social security numbers and home addresses shall not be included on weekly transmittals. Instead the payrolls shall only need to include an individually identifying number for each employee (e.g., the last four digits of the employee's social security number). The required weekly payroll information may be submitted in any form desired. Optional Form WH-347 is available for this purpose from the Wage and Hour Division Web site at <http://www.dol.gov/esa/whd/forms/wh347instr.htm> or its successor site. The prime contractor is responsible for the submission of copies of payrolls by all subcontractors. Contractors and subcontractors shall maintain the full social security number and current address of each covered worker, and shall provide them upon request to the contracting agency for transmission to the State DOT, the FHWA or the Wage and Hour Division of the Department of Labor for purposes of an investigation or audit of compliance with prevailing wage requirements. It is not a violation of this section for a prime contractor to require a subcontractor to provide addresses and social security numbers to the prime contractor for its own records, without weekly submission to the contracting agency.

(2) Each payroll submitted shall be accompanied by a "Statement of Compliance," signed by the contractor or subcontractor or his or her agent who pays or supervises the payment of the persons employed under the contract and shall certify the following:

- (i) That the payroll for the payroll period contains the information required to be provided under §5.5(a)(3)(ii) of Regulations, 29 CFR part 5, the appropriate information is being maintained under §5.5(a)(3)(i) of Regulations, 29 CFR part 5, and that such information is correct and complete;
- (ii) That each laborer or mechanic (including each helper, apprentice, and trainee) employed on the contract during the payroll period has been paid the full weekly wages earned, without rebate, either directly or indirectly, and that no deductions have been made either directly or indirectly from the full wages earned, other than permissible deductions as set forth in Regulations, 29 CFR part 3;
- (iii) That each laborer or mechanic has been paid not less than the applicable wage rates and fringe benefits or cash equivalents for the classification of work performed, as specified in the applicable wage determination incorporated into the contract.

(3) The weekly submission of a properly executed certification set forth on the reverse side of Optional Form WH-347 shall satisfy the requirement for submission of the "Statement of Compliance" required by paragraph 3.b.(2) of this section.

(4) The falsification of any of the above certifications may subject the contractor or subcontractor to civil or criminal prosecution under section 1001 of title 18 and section 231 of title 31 of the United States Code.

c. The contractor or subcontractor shall make the records required under paragraph 3.a. of this section available for inspection, copying, or transcription by authorized representatives of the contracting agency, the State DOT, the FHWA, or the Department of Labor, and shall permit such representatives to interview employees during working hours on the job. If the contractor or subcontractor fails to submit the required records or to make them available, the FHWA may, after written notice to the contractor, the contracting agency or the State DOT, take such action as may be necessary to cause the suspension of any further payment, advance, or guarantee of funds. Furthermore, failure to submit the required records upon request or to make such records available may be grounds for debarment action pursuant to 29 CFR 5.12.

4. Apprentices and trainees

a. Apprentices (programs of the USDOL).

Apprentices will be permitted to work at less than the predetermined rate for the work they performed when they are employed pursuant to and individually registered in a bona fide apprenticeship program registered with the U.S. Department of Labor, Employment and Training Administration, Office of Apprenticeship Training, Employer and Labor Services, or with a State Apprenticeship Agency recognized by the Office, or if a person is employed in his or her first 90 days of probationary employment as an apprentice in such an apprenticeship program, who is not individually registered in the program, but who has been certified by the Office of Apprenticeship Training, Employer and Labor Services or a State Apprenticeship Agency (where appropriate) to be eligible for probationary employment as an apprentice.

The allowable ratio of apprentices to journeymen on the job site in any craft classification shall not be greater than the ratio permitted to the contractor as to the entire work force under the registered program. Any worker listed on a payroll at an apprentice wage rate, who is not registered or otherwise employed as stated above, shall be paid not less than the applicable wage rate on the wage determination for the classification of work actually performed. In addition, any apprentice performing work on the job site in excess of the ratio permitted under the registered program shall be paid not less than the applicable wage rate on the wage determination for the work actually performed. Where a contractor is performing construction on a project in a locality other than that in which its program is registered, the ratios and wage rates (expressed in percentages of the journeyman's hourly rate) specified in the contractor's or subcontractor's registered program shall be observed.

Every apprentice must be paid at not less than the rate specified in the registered program for the apprentice's level of progress, expressed as a percentage of the journeymen hourly rate specified in the applicable wage determination. Apprentices shall be paid fringe benefits in accordance with the provisions of the apprenticeship program. If the apprenticeship program does not specify fringe benefits, apprentices must be paid the full amount of fringe benefits listed on the wage determination for the applicable classification. If the Administrator determines that a different practice prevails for the applicable apprentice classification, fringes shall be paid in accordance with that determination.

In the event the Office of Apprenticeship Training, Employer and Labor Services, or a State Apprenticeship Agency recognized by the Office, withdraws approval of an apprenticeship program, the contractor will no longer be permitted to utilize apprentices at less than the applicable predetermined rate for the work performed until an acceptable program is approved.

b. Trainees (programs of the USDOL).

Except as provided in 29 CFR 5.16, trainees will not be permitted to work at less than the predetermined rate for the work performed unless they are employed pursuant to and individually registered in a program

which has received prior approval, evidenced by formal certification by the U.S. Department of Labor, Employment and Training Administration.

The ratio of trainees to journeymen on the job site shall not be greater than permitted under the plan approved by the Employment and Training Administration.

Every trainee must be paid at not less than the rate specified in the approved program for the trainee's level of progress, expressed as a percentage of the journeyman hourly rate specified in the applicable wage determination. Trainees shall be paid fringe benefits in accordance with the provisions of the trainee program. If the trainee program does not mention fringe benefits, trainees shall be paid the full amount of fringe benefits listed on the wage determination unless the Administrator of the Wage and Hour Division determines that there is an apprenticeship program associated with the corresponding journeyman wage rate on the wage determination which provides for less than full fringe benefits for apprentices. Any employee listed on the payroll at a trainee rate who is not registered and participating in a training plan approved by the Employment and Training Administration shall be paid not less than the applicable wage rate on the wage determination for the classification of work actually performed. In addition, any trainee performing work on the job site in excess of the ratio permitted under the registered program shall be paid not less than the applicable wage rate on the wage determination for the work actually performed.

In the event the Employment and Training Administration withdraws approval of a training program, the contractor will no longer be permitted to utilize trainees at less than the applicable predetermined rate for the work performed until an acceptable program is approved.

- c. Equal employment opportunity. The utilization of apprentices, trainees and journeymen under this part shall be in conformity with the equal employment opportunity requirements of Executive Order 11246, as amended, and 29 CFR part 30.
- d. Apprentices and Trainees (programs of the U.S. DOT).

Apprentices and trainees working under apprenticeship and skill training programs which have been certified by the Secretary of Transportation as promoting EEO in connection with Federal-aid highway construction programs are not subject to the requirements of paragraph 4 of this Section IV. The straight time hourly wage rates for apprentices and trainees under such programs will be established by the particular programs. The ratio of apprentices and trainees to journeymen shall not be greater than permitted by the terms of the particular program.

5. Compliance with Copeland Act requirements. The contractor shall comply with the requirements of 29 CFR part 3, which are incorporated by reference in this contract.

6. Subcontracts. The contractor or subcontractor shall insert Form FHWA-1273 in any subcontracts and also require the subcontractors to include Form FHWA-1273 in any lower tier subcontracts. The prime contractor shall be responsible for the compliance by any subcontractor or lower tier subcontractor with all the contract clauses in 29 CFR 5.5.

7. Contract termination: debarment. A breach of the contract clauses in 29 CFR 5.5 may be grounds for termination of the contract, and for debarment as a contractor and a subcontractor as provided in 29 CFR 5.12.

8. Compliance with Davis-Bacon and Related Act requirements. All rulings and interpretations of the Davis-Bacon and Related Acts contained in 29 CFR parts 1, 3, and 5 are herein incorporated by reference in this contract.

9. Disputes concerning labor standards. Disputes arising out of the labor standards provisions of this contract shall not be subject to the general disputes clause of this contract. Such disputes shall be resolved in accordance with the procedures of the Department of Labor set forth in 29 CFR parts 5, 6, and 7. Disputes within the meaning of this clause include disputes between the contractor (or any of its subcontractors) and the contracting agency, the U.S. Department of Labor, or the employees or their representatives.

10. Certification of eligibility.

- a. By entering into this contract, the contractor certifies that neither it (nor he or she) nor any person or firm who has an interest in the contractor's firm is a person or firm ineligible to be awarded Government contracts by virtue of section 3(a) of the Davis-Bacon Act or 29 CFR 5.12(a)(1).
- b. No part of this contract shall be subcontracted to any person or firm ineligible for award of a Government contract by virtue of section 3(a) of the Davis-Bacon Act or 29 CFR 5.12(a)(1).
- c. The penalty for making false statements is prescribed in the U.S. Criminal Code, 18 U.S.C. 1001.

V. CONTRACT WORK HOURS AND SAFETY STANDARDS ACT

The following clauses apply to any Federal-aid construction contract in an amount in excess of \$100,000 and subject to the overtime provisions of the Contract Work Hours and Safety Standards Act. These clauses shall be inserted in addition to the clauses required by 29 CFR 5.5(a) or 29 CFR 4.6. As used in this paragraph, the terms laborers and mechanics include watchmen and guards.

1. Overtime requirements. No contractor or subcontractor contracting for any part of the contract work which may require or involve the employment of laborers or mechanics shall require or permit any such laborer or mechanic in any workweek in which he or she is employed on such work to work in excess of forty hours in such workweek unless such laborer or mechanic receives compensation at a rate not less than one and one-half times the basic rate of pay for all hours worked in excess of forty hours in such workweek.

2. Violation; liability for unpaid wages; liquidated damages. In the event of any violation of the clause set forth in paragraph (1.) of this section, the contractor and any subcontractor responsible therefor shall be liable for the unpaid wages. In addition, such contractor and subcontractor shall be liable to the United States (in the case of work done under contract for the District of Columbia or a territory, to such District or to such territory), for liquidated damages. Such liquidated damages shall be computed with respect to each individual laborer or mechanic, including watchmen and guards, employed in violation of the clause set forth in paragraph (1.) of this section, in the sum of \$10 for each calendar day on which such individual was required or permitted to work in excess of the standard workweek of forty hours without payment of the overtime wages required by the clause set forth in paragraph (1.) of this section.

3. Withholding for unpaid wages and liquidated damages. The FHWA or the contacting agency shall upon its own action or upon written request of an authorized representative of the Department of Labor withhold or cause to be withheld, from any moneys payable on account of work performed by the contractor or subcontractor under any such contract or any other Federal contract with the same prime contractor, or any other federally-assisted contract subject to the Contract Work Hours and Safety Standards Act, which is held by the same prime contractor, such sums as may be determined to be necessary to satisfy any liabilities of such contractor or subcontractor for unpaid wages and liquidated damages as provided in the clause set forth in paragraph (2.) of this section.

4. Subcontracts. The contractor or subcontractor shall insert in any subcontracts the clauses set forth in paragraph (1.) through (4.) of this section and also a clause requiring the subcontractors to include these clauses in any lower tier subcontracts. The prime contractor shall be responsible for compliance by any subcontractor or lower tier subcontractor with the clauses set forth in paragraphs (1.) through (4.) of this section.

VI. SUBLETTING OR ASSIGNING THE CONTRACT

This provision is applicable to all Federal-aid construction contracts on the National Highway System.

1. The contractor shall perform with its own organization contract work amounting to not less than 30 percent

(or a greater percentage if specified elsewhere in the contract) of the total original contract price, excluding any specialty items designated by the contracting agency. Specialty items may be performed by subcontract and the amount of any such specialty items performed may be deducted from the total original contract price before computing the amount of work required to be performed by the contractor's own organization (23 CFR 635.116).

a. The term "perform work with its own organization" refers to workers employed or leased by the prime contractor, and equipment owned or rented by the prime contractor, with or without operators. Such term does not include employees or equipment of a subcontractor or lower tier subcontractor, agents of the prime contractor, or any other assignees. The term may include payments for the costs of hiring leased employees from an employee leasing firm meeting all relevant Federal and State regulatory requirements. Leased employees may only be included in this term if the prime contractor meets all of the following conditions:

- (1) the prime contractor maintains control over the supervision of the day-to-day activities of the leased employees;
- (2) the prime contractor remains responsible for the quality of the work of the leased employees;
- (3) the prime contractor retains all power to accept or exclude individual employees from work on the project; and
- (4) the prime contractor remains ultimately responsible for the payment of predetermined minimum wages, the submission of payrolls, statements of compliance and all other Federal regulatory requirements.

b. "Specialty Items" shall be construed to be limited to work that requires highly specialized knowledge, abilities, or equipment not ordinarily available in the type of contracting organizations qualified and expected to bid or propose on the contract as a whole and in general are to be limited to minor components of the overall contract.

2. The contract amount upon which the requirements set forth in paragraph (1) of Section VI is computed includes the cost of material and manufactured products which are to be purchased or produced by the contractor under the contract provisions.

3. The contractor shall furnish (a) a competent superintendent or supervisor who is employed by the firm, has full authority to direct performance of the work in accordance with the contract requirements, and is in charge of all construction operations (regardless of who performs the work) and (b) such other of its own organizational resources (supervision, management, and engineering services) as the contracting officer determines is necessary to assure the performance of the contract.

4. No portion of the contract shall be sublet, assigned or otherwise disposed of except with the written consent of the contracting officer, or authorized representative, and such consent when given shall not be construed to relieve the contractor of any responsibility for the fulfillment of the contract. Written consent will be given only after the contracting agency has assured that each subcontract is evidenced in writing and that it contains all pertinent provisions and requirements of the prime contract.

5. The 30% self-performance requirement of paragraph (1) is not applicable to design-build contracts; however, contracting agencies may establish their own self-performance requirements.

VII. SAFETY: ACCIDENT PREVENTION

This provision is applicable to all Federal-aid construction contracts and to all related subcontracts.

1. In the performance of this contract the contractor shall comply with all applicable Federal, State, and local laws governing safety, health, and sanitation (23 CFR 635). The contractor shall provide all safeguards, safety devices and protective equipment and take any other needed actions as it determines, or as the contracting officer may determine, to be reasonably necessary to protect the life and health of employees on the job and the safety of the public and to protect property in connection with the performance of the work covered by the contract.

2. It is a condition of this contract, and shall be made a condition of each subcontract, which the contractor enters into pursuant to this contract, that the contractor and any subcontractor shall not permit any employee, in performance of the contract, to work in surroundings or under conditions which are unsanitary, hazardous or dangerous to his/her health or safety, as determined under construction safety and health standards (29 CFR 1926) promulgated by the Secretary of Labor, in accordance with Section 107 of the Contract Work Hours and Safety Standards Act (40 U.S.C. 3704).

3. Pursuant to 29 CFR 1926.3, it is a condition of this contract that the Secretary of Labor or authorized representative thereof, shall have right of entry to any site of contract performance to inspect or investigate the matter of compliance with the construction safety and health standards and to carry out the duties of the Secretary under Section 107 of the Contract Work Hours and Safety Standards Act (40 U.S.C.3704).

VIII. FALSE STATEMENTS CONCERNING HIGHWAY PROJECTS

This provision is applicable to all Federal-aid construction contracts and to all related subcontracts.

In order to assure high quality and durable construction in conformity with approved plans and specifications and a high degree of reliability on statements and representations made by engineers, contractors, suppliers, and workers on Federal-aid highway projects, it is essential that all persons concerned with the project perform their functions as carefully, thoroughly, and honestly as possible. Willful falsification, distortion, or misrepresentation with respect to any facts related to the project is a violation of Federal law. To prevent any misunderstanding regarding the seriousness of these and similar acts, Form FHWA-1022 shall be posted on each Federal-aid highway project (23 CFR 635) in one or more places where it is readily available to all persons concerned with the project:

18 U.S.C. 1020 reads as follows:

"Whoever, being an officer, agent, or employee of the United States, or of any State or Territory, or whoever, whether a person, association, firm, or corporation, knowingly makes any false statement, false representation, or false report as to the character, quality, quantity, or cost of the material used or to be used,

or the quantity or quality of the work performed or to be performed, or the cost thereof in connection with the submission of plans, maps, specifications, contracts, or costs of construction on any highway or related project submitted for approval to the Secretary of Transportation; or

Whoever knowingly makes any false statement, false representation, false report or false claim with respect to the character, quality, quantity, or cost of any work performed or to be performed, or materials furnished or to be furnished, in connection with the construction of any highway or related project approved by the Secretary of Transportation; or

Whoever knowingly makes any false statement or false representation as to material fact in any statement, certificate, or report submitted pursuant to provisions of the Federal-aid Roads Act approved July 1, 1916, (39 Stat. 355), as amended and supplemented;

Shall be fined under this title or imprisoned not more than 5 years or both."

IX. IMPLEMENTATION OF CLEAN AIR ACT AND FEDERAL WATER POLLUTION CONTROL ACT

This provision is applicable to all Federal-aid construction contracts and to all related subcontracts.

By submission of this bid/proposal or the execution of this contract, or subcontract, as appropriate, the bidder, proposer, Federal-aid construction contractor, or subcontractor, as appropriate, will be deemed to have stipulated as follows:

1. That any person who is or will be utilized in the performance of this contract is not prohibited from receiving an award due to a violation of Section 508 of the Clean Water Act or Section 306 of the Clean Air Act.
2. That the contractor agrees to include or cause to be included the requirements of paragraph (1) of this Section X in every subcontract, and further agrees to take such action as the contracting agency may direct as a means of enforcing such requirements.

X. CERTIFICATION REGARDING DEBARMENT, SUSPENSION, INELIGIBILITY AND VOLUNTARY EXCLUSION

This provision is applicable to all Federal-aid construction contracts, design-build contracts, subcontracts, lower-tier subcontracts, purchase orders, lease agreements, consultant contracts or any other covered transaction requiring FHWA approval or that is estimated to cost \$25,000 or more – as defined in 2 CFR Parts 180 and 1200.

1. Instructions for Certification – First Tier Participants:
 - a. By signing and submitting this proposal, the prospective first tier participant is providing the certification set out below.
 - b. The inability of a person to provide the certification set out below will not necessarily result in denial of participation in this covered transaction. The prospective first tier participant shall submit an explanation of why it cannot provide the certification set out below. The certification or explanation will be considered in connection with the department or agency's determination whether to enter into this

transaction. However, failure of the prospective first tier participant to furnish a certification or an explanation shall disqualify such a person from participation in this transaction.

c. The certification in this clause is a material representation of fact upon which reliance was placed when the contracting agency determined to enter into this transaction. If it is later determined that the prospective participant knowingly rendered an erroneous certification, in addition to other remedies available to the Federal Government, the contracting agency may terminate this transaction for cause of default.

d. The prospective first tier participant shall provide immediate written notice to the contracting agency to whom this proposal is submitted if any time the prospective first tier participant learns that its certification was erroneous when submitted or has become erroneous by reason of changed circumstances.

e. The terms "covered transaction," "debarred," "suspended," "ineligible," "participant," "person," "principal," and "voluntarily excluded," as used in this clause, are defined in 2 CFR Parts 180 and 1200. "First Tier Covered Transactions" refers to any covered transaction between a grantee or subgrantee of Federal funds and a participant (such as the prime or general contract). "Lower Tier Covered Transactions" refers to any covered transaction under a First Tier Covered Transaction (such as subcontracts). "First Tier Participant" refers to the participant who has entered into a covered transaction with a grantee or subgrantee of Federal funds (such as the prime or general contractor). "Lower Tier Participant" refers any participant who has entered into a covered transaction with a First Tier Participant or other Lower Tier Participants (such as subcontractors and suppliers).

f. The prospective first tier participant agrees by submitting this proposal that, should the proposed covered transaction be entered into, it shall not knowingly enter into any lower tier covered transaction with a person who is debarred, suspended, declared ineligible, or voluntarily excluded from participation in this covered transaction, unless authorized by the department or agency entering into this transaction.

g. The prospective first tier participant further agrees by submitting this proposal that it will include the clause titled "Certification Regarding Debarment, Suspension, Ineligibility and Voluntary Exclusion-Lower Tier Covered Transactions," provided by the department or contracting agency, entering into this covered transaction, without modification, in all lower tier covered transactions and in all solicitations for lower tier covered transactions exceeding the \$25,000 threshold.

h. A participant in a covered transaction may rely upon a certification of a prospective participant in a lower tier covered transaction that is not debarred, suspended, ineligible, or voluntarily excluded from the covered transaction, unless it knows that the certification is erroneous. A participant is responsible for ensuring that its principals are not suspended, debarred, or otherwise ineligible to participate in covered transactions. To verify the eligibility of its principals, as well as the eligibility of any lower tier prospective participants, each participant may, but is not required to, check the Excluded Parties List System website (<https://www.epls.gov/>), which is compiled by the General Services Administration.

i. Nothing contained in the foregoing shall be construed to require the establishment of a system of records in order to render in good faith the certification required by this clause. The knowledge and information of the prospective participant is not required to exceed that which is normally possessed by a prudent person in the ordinary course of business dealings.

j. Except for transactions authorized under paragraph (f) of these instructions, if a participant in a covered transaction knowingly enters into a lower tier covered transaction with a person who is suspended, debarred, ineligible, or voluntarily excluded from participation in this transaction, in addition to other remedies

available to the Federal Government, the department or agency may terminate this transaction for cause or default.

* * * * *

2. Certification Regarding Debarment, Suspension, Ineligibility and Voluntary Exclusion – First Tier Participants:

a. The prospective first tier participant certifies to the best of its knowledge and belief, that it and its principals:

- (1) Are not presently debarred, suspended, proposed for debarment, declared ineligible, or voluntarily excluded from participating in covered transactions by any Federal department or agency;
- (2) Have not within a three-year period preceding this proposal been convicted of or had a civil judgment rendered against them for commission of fraud or a criminal offense in connection with obtaining, attempting to obtain, or performing a public (Federal, State or local) transaction or contract under a public transaction; violation of Federal or State antitrust statutes or commission of embezzlement, theft, forgery, bribery, falsification or destruction of records, making false statements, or receiving stolen property;
- (3) Are not presently indicted for or otherwise criminally or civilly charged by a governmental entity (Federal, State or local) with commission of any of the offenses enumerated in paragraph (a)(2) of this certification; and
- (4) Have not within a three-year period preceding this application/proposal had one or more public transactions (Federal, State or local) terminated for cause or default.

b. Where the prospective participant is unable to certify to any of the statements in this certification, such prospective participant shall attach an explanation to this proposal.

2. Instructions for Certification - Lower Tier Participants:

(Applicable to all subcontracts, purchase orders and other lower tier transactions requiring prior FHWA approval or estimated to cost \$25,000 or more - 2 CFR Parts 180 and 1200)

a. By signing and submitting this proposal, the prospective lower tier is providing the certification set out below.

b. The certification in this clause is a material representation of fact upon which reliance was placed when this transaction was entered into. If it is later determined that the prospective lower tier participant knowingly rendered an erroneous certification, in addition to other remedies available to the Federal Government, the department, or agency with which this transaction originated may pursue available remedies, including suspension and/or debarment.

c. The prospective lower tier participant shall provide immediate written notice to the person to which this proposal is submitted if at any time the prospective lower tier participant learns that its certification was erroneous by reason of changed circumstances.

d. The terms "covered transaction," "debarred," "suspended," "ineligible," "participant," "person," "principal," and "voluntarily excluded," as used in this clause, are defined in 2 CFR Parts 180 and 1200. You may contact the person to which this proposal is submitted for assistance in obtaining a copy of those

regulations. "First Tier Covered Transactions" refers to any covered transaction between a grantee or subgrantee of Federal funds and a participant (such as the prime or general contract). "Lower Tier Covered Transactions" refers to any covered transaction under a First Tier Covered Transaction (such as subcontracts). "First Tier Participant" refers to the participant who has entered into a covered transaction with a grantee or subgrantee of Federal funds (such as the prime or general contractor). "Lower Tier Participant" refers any participant who has entered into a covered transaction with a First Tier Participant or other Lower Tier Participants (such as subcontractors and suppliers).

e. The prospective lower tier participant agrees by submitting this proposal that, should the proposed covered transaction be entered into, it shall not knowingly enter into any lower tier covered transaction with a person who is debarred, suspended, declared ineligible, or voluntarily excluded from participation in this covered transaction, unless authorized by the department or agency with which this transaction originated.

f. The prospective lower tier participant further agrees by submitting this proposal that it will include this clause titled "Certification Regarding Debarment, Suspension, Ineligibility and Voluntary Exclusion--Lower Tier Covered Transaction," without modification, in all lower tier covered transactions and in all solicitations for lower tier covered transactions exceeding the \$25,000 threshold.

g. A participant in a covered transaction may rely upon a certification of a prospective participant in a lower tier covered transaction that is not debarred, suspended, ineligible, or voluntarily excluded from the covered transaction, unless it knows that the certification is erroneous. A participant is responsible for ensuring that its principals are not suspended, debarred, or otherwise ineligible to participate in covered transactions. To verify the eligibility of its principals, as well as the eligibility of any lower tier prospective participants, each participant may, but is not required to, check the Excluded Parties List System website (<https://www.epls.gov/>), which is compiled by the General Services Administration.

h. Nothing contained in the foregoing shall be construed to require establishment of a system of records in order to render in good faith the certification required by this clause. The knowledge and information of participant is not required to exceed that which is normally possessed by a prudent person in the ordinary course of business dealings.

i. Except for transactions authorized under paragraph e of these instructions, if a participant in a covered transaction knowingly enters into a lower tier covered transaction with a person who is suspended, debarred, ineligible, or voluntarily excluded from participation in this transaction, in addition to other remedies available to the Federal Government, the department or agency with which this transaction originated may pursue available remedies, including suspension and/or debarment.

* * * * *

Certification Regarding Debarment, Suspension, Ineligibility and Voluntary Exclusion--Lower Tier Participants:

1. The prospective lower tier participant certifies, by submission of this proposal, that neither it nor its principals is presently debarred, suspended, proposed for debarment, declared ineligible, or voluntarily excluded from participating in covered transactions by any Federal department or agency.

2. Where the prospective lower tier participant is unable to certify to any of the statements in this certification, such prospective participant shall attach an explanation to this proposal.

* * * * *

XI. CERTIFICATION REGARDING USE OF CONTRACT FUNDS FOR LOBBYING

This provision is applicable to all Federal-aid construction contracts and to all related subcontracts which exceed \$100,000 (49 CFR 20).

1. The prospective participant certifies, by signing and submitting this bid or proposal, to the best of his or her knowledge and belief, that:

- a. No Federal appropriated funds have been paid or will be paid, by or on behalf of the undersigned, to any person for influencing or attempting to influence an officer or employee of any Federal agency, a Member of Congress, an officer or employee of Congress, or an employee of a Member of Congress in connection with the awarding of any Federal contract, the making of any Federal grant, the making of any Federal loan, the entering into of any cooperative agreement, and the extension, continuation, renewal, amendment, or modification of any Federal contract, grant, loan, or cooperative agreement.
- b. If any funds other than Federal appropriated funds have been paid or will be paid to any person for influencing or attempting to influence an officer or employee of any Federal agency, a Member of Congress, an officer or employee of Congress, or an employee of a Member of Congress in connection with this Federal contract, grant, loan, or cooperative agreement, the undersigned shall complete and submit Standard Form-LLL, "Disclosure Form to Report Lobbying," in accordance with its instructions.

2. This certification is a material representation of fact upon which reliance was placed when this transaction was made or entered into. Submission of this certification is a prerequisite for making or entering into this transaction imposed by 31 U.S.C. 1352. Any person who fails to file the required certification shall be subject to a civil penalty of not less than \$10,000 and not more than \$100,000 for each such failure.

3. The prospective participant also agrees by submitting its bid or proposal that the participant shall require that the language of this certification be included in all lower tier subcontracts, which exceed \$100,000 and that all such recipients shall certify and disclose accordingly.

ATTACHMENT 3 TO EXHIBIT E
FEDERAL PREVAILING WAGE RATE

(Subject to change)

State: Texas

Construction Types: Heavy and Highway

County: Travis

	Rates
Agricultural Tractor Operator	\$ 12.69
Asphalt Distributor Operator	\$ 15.55
Asphalt Paving Machine Operator	\$ 14.36
Asphalt Raker	\$ 12.12
Boom Truck Operator	\$ 18.36
Broom or Sweeper Operator	\$ 11.04
Concrete Finisher, Paving and Structures	\$ 12.56
Concrete Pavement Finishing Machine Operator	\$ 15.48
Crane Operator, Hydraulic 80 Tons or Less	\$ 18.36
Crane Operator, Lattice Boom 80 Tons or Less	\$ 15.87
Crane Operator, Lattice Boom Over 80 Tons	\$ 19.38
Crawler Tractor Operator	\$ 15.67
Directional Drilling Locator	\$ 11.67
Directional Drilling Operator	\$ 17.24
Electrician	\$ 26.35
Excavator Operator, 50,000 Pounds or Less	\$ 12.88
Excavator Operator, Over 50,000 Pounds	\$ 17.71
Flagger	\$ 9.45
Form Builder/Setter, Structures	\$ 12.87
Form Setter, Paving & Curb	\$ 12.94
Foundation Drill Operator, Truck Mounted	\$ 16.93
Front End Loader Operator 3 CY or Less	\$ 13.04
Front End Loader Operator Over 3 CY	\$ 13.21
Laborer, Common	\$ 10.50
Laborer, Utility	\$ 12.27

Loader/Backhoe Operator	\$ 14.12
Mechanic	\$ 17.10
Milling Machine Operator	\$ 14.18
Motor Grader Operator, Fine Grade	\$ 18.51
Motor Grader Operator, Rough	\$ 14.63
Off Road Hauler	\$ 11.88
Painter, Structures	\$ 18.34
Pavement Marking Machine Operator	\$ 19.17
Pipelayer	\$ 12.79
Reclaimer/Pulverizer Operator	\$ 12.88
Reinforcing Steel Worker	\$ 14.00
Roller Operator, Asphalt	\$ 12.78
Roller Operator, Other	\$ 10.50
Scraper Operator	\$ 12.27
Servicer	\$ 14.51
Spreader Box Operator	\$ 14.04
Structural Steel Worker	\$ 19.29
Traffic Signal/Light Pole Worker	\$ 16.00
Trenching Machine Operator, Heavy	\$ 18.48
Truck Driver, Lowboy-Float	\$ 15.66
Truck Driver, Single Axle	\$ 11.79
Truck Driver, Single or Tandem Axle Dump Truck	\$ 11.68
Truck Driver, Tandem Axle with Semi-Trailer	\$ 12.81
Welder	\$ 15.97
Work Zone Barricade Servicer	\$ 11.85

Unlisted classifications needed for work not included within the scope of the classifications listed may be added after award only as provided in the labor standards contract clauses (29CFR 5.5 (a) (1) (ii)).

In the listing above, the "SU" designation means that rates listed under the identifier do not reflect collectively bargained wage and fringe benefit rates. Other designations indicate unions whose rates have been determined to be prevailing.

WAGE DETERMINATION APPEALS PROCESS

1.) Has there been an initial decision in the matter? This can be:

- * an existing published wage determination
- * a survey underlying a wage determination
- * a Wage and Hour Division letter setting forth a position on a wage determination matter
- * a conformance (additional classification and rate) ruling

On survey related matters, initial contact, including requests for summaries of surveys, should be with the Wage and Hour Regional Office for the area in which the survey was conducted because those Regional Offices have responsibility for the Davis-Bacon survey program. If the response from this initial contact is not satisfactory, then the process described in 2.) and 3.) should be followed.

With regard to any other matter not yet ripe for the formal process described here, initial contact should be with the Branch of Construction Wage Determinations. Write to:

Branch of Construction Wage Determinations
 Wage and Hour Division
 U.S. Department of Labor
 200 Constitution Avenue, N.W.
 Washington, DC 20210

2.) If the answer to the question in 1.) is yes, then an interested party (those affected by the action) can request review and reconsideration from the Wage and Hour Administrator (See 29 CFR Part 1.8 and 29 CFR Part 7). Write to:

Wage and Hour Administrator
 U.S. Department of Labor
 200 Constitution Avenue, N.W.
 Washington, DC 20210

The request should be accompanied by a full statement of the interested party's position and by any information (wage payment data, project description, area practice material, etc.) that the requestor considers relevant to the issue.

3.) If the decision of the Administrator is not favorable, an interested party may appeal directly to the Administrative Review Board (formerly the Wage Appeals Board). Write to:

Administrative Review Board
 U.S. Department of Labor
 200 Constitution Avenue, N.W.
 Washington, DC 20210

4.) All decisions by the Administrative Review Board are final.

=====

END OF GENERAL DECISION

ATTACHMENT 4 TO EXHIBIT E

EQUAL EMPLOYMENT OPPORTUNITY

SPECIAL PROVISION

000---006

**Standard Federal Equal Employment Opportunity
Construction Contract Specifications (Executive Order 11246)**

1. As used in these specifications:
 - a. "Covered area" means the geographical area described in the solicitation from which this contract resulted;
 - b. "Director" means Director, Office of Federal Contract Compliance Programs, United States Department of Labor, or any person to whom the Director delegates authority;
 - c. "Employer identification number" means the Federal Social Security number used on the Employer's Quarterly Federal Tax Return, U.S. Treasury Department Form 941.
 - d. "Minority" includes:
 - Black (all persons having origins in any of the Black African racial groups not of Hispanic origin);
 - Hispanic (all persons of Mexican, Puerto Rican, Cuban, Central or South American or other Spanish Culture or origin, regardless of race);
 - Asian and Pacific Islander (all persons having origins in any of the original peoples of the Far East, Southeast Asia, the Indian Subcontinent, or the Pacific Islands); and
 - American Indian or Alaskan Native (all persons having origins in any of the original peoples of North American and maintaining identifiable tribal affiliations through membership and participation or community identification).
2. Whenever the contractor, or any subcontractor at any tier, subcontracts a portion of the work involving any construction trade, it shall physically include in each subcontract in excess of \$10,000 the provisions of these specifications and the Notice which contains the applicable goals for minority and female participation and which is set forth in the solicitations from which this contract resulted.
3. If the contractor is participating (pursuant to 41 CFR 60-4.5) in a Hometown Plan approved by the U. S. Department of Labor in the covered area either individually or through an association, its affirmative action obligations on all work in the Hometown Plan area (including goals and timetables) shall be in accordance with that plan for those trades which have unions participating in the Hometown Plan. Contractors must be able to demonstrate their participation in and compliance with the provisions of any such Hometown Plan. Each contractor or subcontractor participating in an approved Hometown Plan is individually required to comply with its obligations under the EEO clause, and to

make a good faith effort to achieve each goal under the Hometown Plan in each trade in which it has employees. The overall good faith performance by other contractors or subcontractors toward a goal in an approved Hometown Plan does not excuse any covered contractor's or subcontractor's failure to take good faith efforts to achieve the Hometown Plan goals and timetables.

4. The contractor shall implement the specific affirmative action standards provided in paragraphs 7a through p of these specifications. The goals set forth in the solicitation from which this contract resulted are expressed as percentages of the total hours of employment and training of minority and female utilization the contractor should reasonably be able to achieve in each construction trade in which it has employees in the covered area. Covered construction contractors performing contracts in geographical areas where they do not have a Federal or federally assisted construction contract shall apply the minority and female goals established for the geographical area where the contract is being performed. Goals are published periodically in the Federal Register in notice form and such notices may be obtained from any Office of Federal Contract Compliance Programs office or any Federal procurement contracting officer. The contractor is expected to make substantially uniform progress toward its goals in each craft during the period specified.
5. Neither the provisions of any collective bargaining agreement, nor the failure by a union with whom the contractor has a collective bargaining agreement, to refer either minorities or women shall excuse the contractor's obligations under these specifications, Executive Order 11246, or the regulations promulgated pursuant thereto.
6. In order for the nonworking training hours of apprentices and trainees to be counted in meeting the goals, such apprentices and trainees must be employed by the contractor during the training period, and the contractor must have made a commitment to employ the apprentices and trainees at the completion of their training, subject to the availability of employment opportunities. Trainees must be trained pursuant to training programs approved by the U. S. Department of Labor.
7. The contractor shall take specific affirmative actions to ensure equal employment opportunity. The evaluation of the contractor's compliance with these specifications shall be based upon its effort to achieve maximum results from its actions. The contractor shall document these efforts fully, and shall implement affirmative action steps at least as extensive as the following:
 - a. Ensure and maintain a working environment free of harassment, intimidation, and coercion at all sites, and in all facilities at which the contractor's employees are assigned to work. The contractor, where possible, will assign two or more women to each construction project. The contractor shall specifically ensure that all foremen, superintendents, and other on-site supervisory personnel are aware of and carry out the contractor's obligation to maintain such a working environment, with specific attention to minority or female individuals working at such sites or in such facilities.
 - b. Establish and maintain a current list of minority and female recruitment sources, provide written notification to minority and female recruitment sources and to community organizations when the contractor or its unions have employment opportunities available, and maintain a record of the organizations' responses.

- c. Maintain a current file of the names, addresses and telephone numbers of each minority and female off-the-street applicant and minority or female referral from a union, a recruitment source or community organization and of what action was taken with respect to each such individual. If such individual was sent to the union hiring hall for referral and was not referred back to the Contractor by the union or, if referred, not employed by the contractor, this shall be documented in the file with the reason therefore, along with whatever additional actions the contractor may have taken.
- d. Provide immediate written notification to the Director when the union or unions with which the contractor has a collective bargaining agreement has not referred to the contractor a minority person or woman sent by the contractor, or when the contractor has other information that the union referral Process has impeded the contractor's efforts to meet its obligations.
- e. Develop on-the-job training opportunities and/or participate in training programs for the area which expressly include minorities and women, including upgrading programs and apprenticeship and trainee programs relevant to the contractor's employment needs, especially those programs funded or approved by the Department of Labor. The contractor shall provide notice of these programs to the sources compiled under 7b above.
- f. Disseminate the contractor's EEO policy by providing notice of the policy to unions and training programs and requesting their cooperation in assisting the contractor in meeting its EEO obligations; by including it in any policy manual and collective bargaining agreement; by publicizing it in the company newspaper, annual report, etc.; by specific review of the policy with all management personnel and with all minority and female employees at least once a year; and by posting the contractor's EEO policy on bulletin boards accessible to all employees at each location where construction work is performed.
- g. Review, at least annually, the contractor's EEO policy and affirmative action obligations under these specifications with all employees having any responsibility for hiring, assignment, layoff, termination or other employment decisions including specific review of these items with onsite supervisory personnel such as Superintendents, General Foremen, etc., prior to the initiation of construction work at any job site. A written record shall be made and maintained identifying the time and place of these meetings, persons attending, subject matter discussed, and disposition of the subject matter.
- h. Disseminate the contractor's EEO policy externally by including it in any advertising in the news media, specifically including minority and female news media, and providing written notification to and discussing the contractor's EEO policy with other contractors and subcontractors with whom the contractor does or anticipates doing business.
- i. Direct its recruitment efforts, both oral and written, to minority, female and community organizations, to schools with minority and female students and to minority and female recruitment and training serving the Contractor's recruitment area and employment needs. Not later than one month prior to the date for the acceptance of applications for apprenticeship or other training by any recruitment source, the Contractor shall send written notification to organizations such as the above, describing the openings, screening procedures, and tests to be used in the selection process.

- j. Encourage present minority and female employees to recruit other minority persons and women and, where reasonable, provide after school, summer and vacation employment to minority and female youth both on the site and in other areas of a contractor's workforce.
 - k. Validate all tests and other selection requirements where there is an obligation to do so under 41 CFR Part 60-3.
 - l. Conduct, at least annually, an inventory and evaluation at least of all minority and female personnel for promotional opportunities and encourage these employees to seek or to prepare for, through appropriate training, etc., such opportunities.
 - m. Ensure that seniority practices, job classifications, work assignments and other personnel practices, do not have a discriminatory effect by continually monitoring all personnel and employment related activities to ensure that the contractor's EEO policy and the contractor's obligations under these specifications are being carried out.
 - n. Ensure that all facilities and company activities are non-segregated except that separate or single-user toilet and necessary changing facilities shall be provided to assure privacy between the sexes.
 - o. Document and maintain a record of all solicitations of offers for subcontracts from minority and female construction contractors and suppliers, including circulation of solicitations to minority and female contractor associations and other business associations.
 - p. Conduct a review, at least annually, of all supervisors' adherence to and performance under the contractor's EEO policies and affirmative action obligations.
8. Contractors are encouraged to participate in voluntary associations which assist in fulfilling one or more of their affirmative action obligations (7a through p). The efforts of a contractor association, joint contractor-union, contractor-community, or other similar group of which the contractor is a member and participant, may be asserted as fulfilling any one or more of its obligations under 7a through p of these specifications provided that the contractor actively participates in the group, makes every effort to assure that the group has a positive impact on the employment of minorities and women in the industry, ensures that the concrete benefits of the program are reflected in the contractor's minority and female workforce participation, makes a good faith effort to meet its individual goals and timetables, and can provide access to documentation which demonstrates the effectiveness of actions taken on behalf of the contractor. The obligation to comply, however, is the contractor's and failure of such a group to fulfill an obligation shall not be a defense for the contractor's noncompliance.
9. A single goal for minorities and a separate single goal for women have been established. The contractor, however, is required to provide equal employment opportunity and to take affirmative action for all minority groups, both male and female, and all women, both minority and non-minority. Consequently, the contractor may be in violation of the Executive Order if a particular group is employed in a substantially disparate manner (for example, even though the contractor has achieved its goals for women generally, the contractor may be in violation of the Executive Order if a specific minority group of women is underutilized).

10. Nondiscrimination programs require that Federal-aid recipients, subrecipients, and contractors prevent discrimination and ensure nondiscrimination in all of their programs and activities, whether those programs and activities are federally funded or not. The factors prohibited from serving as a basis for action or inaction which discriminates include race, color, national origin, sex, age, and handicap/disability. The efforts to prevent discrimination must address, but not be limited to a program's impacts, access, benefits, participation, treatment, services, contracting opportunities, training opportunities, investigations of complaints, allocations of funds, prioritization of projects, and the functions of right-of-way, research, planning, and design.
11. The contractor shall not enter into any subcontract with any person or firm debarred from Government contracts pursuant to Executive Order 11246.
12. The contractor shall carry out such sanctions and penalties for violation of these specifications and of the Equal Opportunity Clause, including suspension, termination and cancellation of existing subcontracts as may be imposed or ordered pursuant to Executive Order 11246, as amended, and its implementing regulations, by the Office of Federal Contract Compliance Programs. Any contractor who fails to carry out such sanctions and penalties shall be in violation of these specifications and Executive Order 11246, as amended.
13. The contractor, in fulfilling its obligations under these specifications, shall implement specific affirmative action steps, at least as extensive as those standards prescribed in paragraph 7 of these specifications, so as to achieve maximum results from its efforts to ensure equal employment opportunity. If the contractor fails to comply with the requirements of the Executive Order, the implementing regulations, or these specifications, the Director shall proceed in accordance with 41 CFR 60-4.8.
14. The contractor shall designate a responsible official to monitor all employment related activity to ensure that the company EEO policy is being carried out, to submit reports relating to the provisions hereof as may be required by the Government and to keep records. Records shall at least include for each employee the name, address, telephone numbers, construction trade, union affiliation if any, employee identification number when assigned, social security number, race, sex, status (e.g., mechanic, apprentice, trainee, helper, or laborer), dates of changes in status, hours worked per week in the indicated trade, rate of pay, and locations at which the work was performed. Records shall be maintained in an easily understandable and retrievable form; however, to the degree that existing records satisfy this requirement, contractors shall not be required to maintain separate records.
15. Nothing herein provided shall be construed as a limitation upon the application of other laws which establish different standards of compliance or upon the application of requirements for the hiring of local or other area residents (e.g., those under the Public Works Employment Act of 1977 and the Community Development Block Grant Program).
16. In addition to the reporting requirements set forth elsewhere in this contract, the contractor and the subcontractors holding subcontracts, not including material suppliers, of \$10,000 or more, shall submit for every month of July during which work is performed, employment data as contained under Form PR 1391 (Appendix C to 23 CFR, Part 230), and in accordance with the instructions included thereon.

ATTACHMENT 5 TO EXHIBIT E

AFFIRMATIVE ACTION

SPECIAL PROVISION

000--004

**Notice of Requirement for Affirmative Action to
Ensure Equal Employment Opportunity (Executive Order 11246)**

1. General.

In addition to the affirmative action requirements of the Special Provision titled "Standard Federal Equal Employment Opportunity Construction Contract Specifications" as set forth elsewhere in this proposal, the contractor's attention is directed to the specific requirements for utilization of minorities and females as set forth below.

2. Goals.

a. Goals for minority and female participation are hereby established in accordance with 41 CFR 60-4.

b. The goals for minority and female participation expressed in percentage terms for the contractor's aggregate work force in each trade on all construction work in the covered area, are as follows:

Goals for minority participation in each trade (per- cent)	Goals for female participation in each trade (per-cent)
---	--

See Table 1

6.9

c. These goals are applicable to all the contractor's construction work (whether or not it is Federal or federally assisted) performed in the covered area. If the contractor performs construction work in a geographical area located outside of the covered area, it shall apply the goals established for such geographical area where the work is actually performed. With regard to this second area, the contractor also is subject to the goals for both its federally involved and non-federally involved construction. The contractor's compliance with the Executive Order and the regulations in 41 CFR Part 60-4 shall be based on its implementation of the Standard Federal Equal Employment Opportunity Construction Contract Specifications Special Provision and its efforts to meet the goals. The hours of minority and female employment and training must be substantially uniform throughout the length of the contract, and in each trade, and the contractor shall make a good faith effort to employ minorities and women evenly on each of its projects. The transfer of minority and female employees or trainees from contractor to contractor or from project to project for the sole purpose of meeting the contractor's goals shall be a violation of the contract, the Executive Order and the regulations in 41 CFR Part 60-4. Compliance with the goals will be measured against the total work hours performed.

- d. A contractor or subcontractor will be considered in compliance with these provisions by participation in the Texas Highway-Heavy Branch, AGC, Statewide Training and Affirmative Action Plan. Provided that each contractor or subcontractor participating in this plan must individually comply with the equal opportunity clause set forth in 41 CFR 60-1.4 and must make a good faith effort to achieve the goals set forth for each participating trade in the plan in which it has employees. The overall good performance of other contractors and subcontractors toward a goal in an approved plan does not excuse any covered contractor's or subcontractor's failure to make good faith efforts to achieve the goals contained in these provisions. Contractors or subcontractors participating in the plan must be able to demonstrate their participation and document their compliance with the provisions of this plan.

3. Subcontracting.

The contractor shall provide written notification to TxDOT within ten Business Days of award of any construction subcontract in excess of \$10,000 at any tier for construction work under the contract resulting from this solicitation pending concurrence of TxDOT in the award. The notification shall list the names, address and telephone number of the subcontractor; employer identification number; estimated dollar amount of the subcontract; estimated starting and completion dates of the subcontract; and the geographical area in which the contract is to be performed.

4. Covered area.

As used in this special provision, and in the contract resulting from this solicitation, the geographical area covered by these goals for female participation is the State of Texas. The geographical area covered by these goals for other minorities are the counties in the State of Texas as indicated in Table 1.

5. Reports.

The contractor is hereby notified that he may be subject to the Office of Federal Contract Compliance Programs (OFCCP) reporting and record keeping requirements as provided for under Executive Order 11246 as amended. OFCCP will provide direct notice to the contractor as to the specific reporting requirements that he will be expected to fulfill.

Table 1

County	Goals for Minority Participation	County	Goals for Minority Participation
Anderson	22.5	Concho	20.0
Andrews	18.9	Cooke	17.2
Angelina	22.5	Coryell	16.4
Aransas	44.2	Cottle	11.0
Archer	11.0	Crane	18.9
Armstrong	11.0	Crockett	20.0
Atascosa	49.4	Crosby	19.5
Austin	27.4	Culberson	49.0
Bailey	19.5	Dallam	11.0
Bandera	49.4	Dallas	18.2

Bastrop	24.2	Dawson	19.5
Baylor	11.0	Deaf Smith	11.0
Bee	44.2	Delta	17.2
Bell	16.4	Denton	18.2
Bexar	47.8	DeWitt	27.4
Blanco	24.2	Dickens	19.5
Borden	19.5	Dimmit	49.4
Bosque	18.6	Donley	11.0
Bowie	19.7	Duval	44.2
Brazoria	27.3	Eastland	10.9
Brazos	23.7	Ector	15.1
Brewster	49.0	Edwards	49.4
Briscoe	11.0	Ellis	18.2
Brooks	44.2	El Paso	57.8
Brown	10.9	Erath	17.2
Burleson	27.4	Falls	18.6
Burnet	24.2	Fannin	17.2
Caldwell	24.2	Fayette	27.4
Calhoun	27.4	Fisher	10.9
Callahan	11.6	Floyd	19.5
Cameron	71.0	Foard	11.0
Camp	20.2	Fort Bend	27.3
Carson	11.0	Franklin	17.2
Cass	20.2	Freestone	18.6
Castro	11.0	Frio	49.4
Chambers	27.4	Gaines	19.5
Cherokee	22.5	Galveston	28.9
Childress	11.0	Garza	19.5
Clay	12.4	Gillespie	49.4
Cochran	19.5	Glasscock	18.9
Coke	20.0	Goliad	27.4
Coleman	10.9	Gonzales	49.4
Collin	18.2	Gray	11.0
Collingsworth	11.0	Grayson	9.4
Colorado	27.4	Gregg	22.8
Comal	47.8	Grimes	27.4
Comanche	10.9	Guadalupe	47.8

County	Goals for Minority Participation	County	Goals for Minority Participation
Hale	19.5	Lavaca	27.4
Hall	11.0	Lee	24.2
Hamilton	18.6	Leon	27.4
Hansford	11.0	Liberty	27.3
Hardeman	11.0	Limestone	18.6
Hardin	22.6	Lipscomb	11.0
Harris	27.3	Live Oak	44.2
Harrison	22.8	Llano	24.2
Hartley	11.0	Loving	18.9
Haskell	10.9	Lubbock	19.6

Hays	24.1	Lynn	19.5
Hemphill	11.0	Madison	27.4
Henderson	22.5	Marion	22.5
Hidalgo	72.8	Martin	18.9
Hill	18.6	Mason	20.0
Hockley	19.5	Matagorda	27.4
Hood	18.2	Maverick	49.4
Hopkins	17.2	McCulloch	20.0
Houston	22.5	McLennan	20.7
Howard	18.9	McMullen	49.4
Hudspeth	49.0	Medina	49.4
Hunt	17.2	Menard	20.0
Hutchinson	11.0	Midland	19.1
Irion	20.0	Milam	18.6
Jack	17.2	Mills	18.6
Jackson	27.4	Mitchell	10.9
Jasper	22.6	Montague	17.2
Jeff Davis	49.0	Montgomery	27.3
Jefferson	22.6	Moore	11.0
Jim Hogg	49.4	Morris	20.2
Jim Wells	44.2	Motley	19.5
Johnson	18.2	Nacogdoches	22.5
Jones	11.6	Navarro	17.2
Karnes	49.4	Newton	22.6
Kaufman	18.2	Nolan	10.9
Kendall	49.4	Nueces	41.7
Kennedy	44.2	Ochiltree	11.0
Kent	10.9	Oldham	11.0
Kerr	49.4	Orange	22.6
Kimble	20.0	Palo Pinto	17.2
King	19.5	Panola	22.5
Kinney	49.4	Parker	18.2
Kleberg	44.2	Parmer	11.0
Knox	10.9	Pecos	18.9
Lamar	20.2	Polk	27.4
Lamb	19.5	Potter	9.3
Lampasas	18.6	Presidio	49.0
LaSalle	49.4	Rains	17.2

County	Goals for Minority Participation	County	Goals for Minority Participation
Randall	9.3	Webb	87.3
Reagan	20.0	Wharton	27.4
Real	49.4	Wheeler	11.0
Red River	20.2	Wichita	12.4
Reeves	18.9	Wilbarger	11.0
Refugio	44.2	Willacy	72.9
Roberts	11.0	Williamson	24.1
Robertson	27.4	Wilson	49.4
Rockwall	18.2	Winkler	18.9

Runnels	20.0	Wise	18.2
Rusk	22.5	Wood	22.5
Sabine	22.6	Yoakum	19.5
San Augustine	22.5	Young	11.0
San Jacinto	27.4	Zapata	49.4
San Patricio	41.7	Zavala	49.4
San Saba	20.0		
Schleicher	20.0		
Scurry	10.9		
Shackelford	10.9		
Shelby	22.5		
Sherman	11.0		
Smith	23.5		
Somervell	17.2		
Starr	72.9		
Stephens	10.9		
Sterling	20.0		
Stonewall	10.9		
Sutton	20.0		
Swisher	11.0		
Tarrant	18.2		
Taylor	11.6		
Terrell	20.0		
Terry	19.5		
Throckmorton	10.9		
Titus	20.2		
Tom Green	19.2		
Travis	24.1		
Trinity	27.4		
Tyler	22.6		
Upshur	22.5		
Upton	18.9		
Uvalde	49.4		
Val Verde	49.4		
Van Zandt	17.2		
Victoria	27.4		
Walker	27.4		
Waller	27.3		
Ward	18.9		
Washington	27.4		

ATTACHMENT 6 TO EXHIBIT E

DEBARMENT AND SUSPENSION CERTIFICATION

1. By signing and submitting its proposal or bid, and by executing the Agreement or Subcontract, each prospective DB Contractor and Subcontractor (at all tiers) shall be deemed to have signed and delivered the following certification:

The undersigned certifies to the best of its knowledge and belief, that it and its principals:

- a. Are not presently debarred, suspended, proposed for debarment, declared ineligible, or voluntarily excluded from covered transactions by any Federal department or agency;
- b. Have not within a 3-year period preceding this proposal been convicted of or had a civil judgment rendered against them for commission of fraud or a criminal offense in connection with obtaining, attempting to obtain, or performing a public (Federal, State or local) transaction or contract under a public transaction; violation of Federal or State antitrust statutes or commission of embezzlement, theft, forgery, bribery, falsification or destruction of records, making false statements, or receiving stolen property;
- c. Are not presently indicted for or otherwise criminally or civilly charged by a governmental entity (Federal, State or local) with commission of any of the offenses enumerated in paragraph 1b of this certification; and
- d. Have not within a 3-year period preceding this application/proposal had one or more public transactions (Federal, State or local) terminated for cause or default.

2. Where the prospective DB Contractor is unable to certify to any of the statements in this certification, such Person shall attach a certification to its proposal or bid, or shall submit it with the executed Agreement or Contract, stating that it is unable to provide the certification and explaining the reasons for such inability.

ATTACHMENT 7 TO EXHIBIT E

CERTIFICATION REGARDING USE OF CONTRACT FUNDS FOR LOBBYING

By signing and submitting its proposal or bid, and by executing the Agreement or Subcontract, each prospective DB Contractor (at all tiers) shall be deemed to have signed and delivered the following:

1. The prospective DB Contractor certifies, to the best of its knowledge and belief, that:
 - a. No Federal appropriated funds have been paid or will be paid, by or on behalf of the undersigned, to any person for influencing or attempting to influence an officer or employee of any Federal agency, a Member of Congress, an officer or employee of Congress, or an employee of a Member of Congress in connection with the awarding of **ANY** Federal contract, the making of any Federal grant, the making of any Federal loan, the entering into of any cooperative agreement, and the extension, continuation, renewal, amendment, or modification of any Federal contract, grant, loan, or cooperative agreement.
 - b. If any funds other than Federal appropriated funds have been paid or will be paid to any person for influencing or attempting to influence an officer or employee of any Federal agency, a Member of Congress, an officer or employee of Congress, or an employee of a Member of Congress in connection with **THIS** Federal contract, grant, loan, or cooperative agreement, the undersigned shall complete and submit Standard Form-LLL, "Disclosure Form to Report Lobbying," in accordance with its instructions, and shall include a copy of said form in its proposal or bid, or submit it with the executed Agreement or Contract.
2. This certification is a material representation of fact upon which reliance was placed when this transaction was made or entered into. Submission of this certification is a prerequisite for making or entering into this transaction imposed by 31 U.S.C. 1352. Any person who fails to file the required certification shall be subject to a civil penalty of not less than \$10,000 and not more than \$100,000 for each such failure.
3. The DB Contractor shall require that the language of this certification be included in all lower tier Contracts which exceed \$100,000 and that all such recipients shall certify and disclose accordingly.
4. The undersigned certifies or affirms the truthfulness and accuracy of each statement of its certification and disclosure, if any. In addition, the undersigned understands and agrees that the provisions of 31 U.S.C. §3801, et seq., apply to this certification and disclosure, if any.

[Note: Pursuant to 31 U.S.C. § 1352(c)(1)-(2)(A), any person who makes a prohibited expenditure or fails to file or amend a required certification or disclosure form shall be subject to a civil penalty of not less than \$10,000 and not more than \$100,000 for each expenditure or failure.]

NOTE: THE DB CONTRACTOR AND EACH SUBCONTRACTOR IS REQUIRED, PURSUANT TO FEDERAL LAW, TO INCLUDE THE ABOVE LANGUAGE IN CONTRACTS OVER \$100,000 AND TO OBTAIN THIS LOBBYING CERTIFICATE FROM EACH CONTRACTOR BEING PAID \$100,000 OR MORE.

ATTACHMENT 8 TO EXHIBIT E
COMPLIANCE WITH BUY AMERICA REQUIREMENTS

The DB Contractor shall comply with the Federal Highway Administration (FHWA) Buy America Requirement in 23 CFR 635.410, which permits FHWA participation in the DB Agreement only if domestic steel and iron will be used on the Project. To be considered domestic, all steel and iron used and all products manufactured from steel and iron must be produced in the United States and all manufacturing processes, including application of a coating, for these materials must occur in the United States. Coating includes all processes that protect or enhance the value of the material to which the coating is applied. This requirement does not preclude a minimal use of foreign steel and iron materials, provided the cost of such materials does not exceed 0.1% of the Development Price under the DB Agreement.

Concurrently with execution of the DB Agreement, the DB Contractor has completed and submitted, or shall complete and submit, to the Mobility Authority a Buy America Certificate, in format below. After submittal, the DB Contractor is bound by its original certification.

A false certification is a criminal act in violation of 18 U.S.C. 1001. Should this DB Agreement be investigated, the DB Contractor has the burden of proof to establish that it is in compliance.

At the DB Contractor's request, the Mobility Authority may, but is not obligated to, seek a waiver of Buy America requirements if grounds for the waiver exist. However, the DB Contractor certifies that it will comply with the applicable Buy America requirements if a waiver of those requirements is not available or not pursued by the Mobility Authority. A request for a waiver shall be treated as a Request for Change Order under [Section 14.3] of the DB Agreement.

The undersigned certifies on behalf of itself and all proposed Subcontractors (at all tiers) that only domestic steel and iron will be used in the Project.

- A. The DB Contractor shall comply with the Federal Highway Administration (“FHWA”) Buy America Requirements of 23 CFR 635.410, which permits FHWA participation in the DB Agreement only if domestic steel and iron will be used on the Project. To be considered domestic, all steel and iron used and all products manufactured from steel and iron must be produced in the United States, and all manufacturing processes, including application of a coating, for these materials must occur in the United States. Coating includes all processes which protect or enhance the value of the material to which the coating is applied. This requirement does not preclude a minimal use of foreign steel and iron materials, provided the cost of such materials does not exceed 0.1% of the DB Price.
- B. A false certification is a criminal act in violation of 18 U.S.C. 1001. Should this DB Agreement be investigated, the DB Contractor has the burden of proof to establish that it is in compliance.
- C. At the DB Contractor’s request, the Mobility Authority may, but is not obligated to, seek a waiver of Buy America requirements if grounds for the waiver exist. However, the DB Contractor certifies that it will comply with the applicable Buy America requirements if a waiver of those requirements is not available or not pursued by the Mobility Authority.

PROPOSER	
SIGNATURE	
NAME (printed or typed)	
TITLE	
DATE	

ATTACHMENT 9 TO EXHIBIT E

**SPECIAL PROVISION
000--003
Notice to All Bidders**

To report bid rigging activities call:

1-800-424-9071

The U.S. Department of Transportation (DOT) operates the above toll-free "hotline" Monday through Friday, 8:00 a.m. to 5:00 p.m., eastern time. Anyone with knowledge of possible bid rigging, bidder collusion, or other fraudulent activities should use the "hotline" to report such activities.

The "hotline" is part of the DOT's continuing effort to identify and investigate highway construction contract fraud and abuse and is operated under the direction of the DOT Inspector General. All information will be treated confidentially and called anonymity will be respected.

ATTACHMENT 10 TO EXHIBIT E

2004 Specifications

SPECIAL PROVISION

Certification of Nondiscrimination in Employment

By signing this proposal, the bidder certifies that he has participated in a previous contract or subcontract subject to the equal opportunity clause, as required by Executive Orders 10925, 11114, or 11246, or if he has not participated in a previous contract of this type, or if he has had previous contract or subcontracts and has not filed, he will file with the Joint Reporting Committee, the Director of the Office of Federal Contract Compliance, a Federal Government contracting or administering agency, or the former President's Committee on Equal Employment Opportunity, all reports due under the applicable filing requirements.

Note: The above certification is required by the Equal Employment Opportunity Regulations of the Secretary of Labor (41 CFR 60-1.7(b)(1)), and must be submitted by bidders and proposed subcontractors only in connection with contracts and subcontracts which are subject to the equal opportunity clause. Contracts and subcontracts which are exempt from the equal opportunity clause are set forth in 41 CFR 60-1.5. (Generally only contracts or subcontracts of \$10,000 or under are exempt.)

Currently, Standard Form 100 (EEO-1) is the only report required by the Executive Orders or their implementing regulations.

Proposed prime contractors and subcontractors who have participated in a previous contract or subcontract subject to the Executive Orders and have not filed the required reports should note that 41 CFR 60-1.7(b)(1) prevents the award of contracts and subcontracts unless such contractor submits a report covering the delinquent period or such other period specified by the Federal Highway Administration or by the Director, Office of Federal Contract Compliance, U. S. Department of Labor.

ATTACHMENT 11 TO EXHIBIT E

2004 Specifications

SPECIAL PROVISION

On-the-Job Training Program

1. **Description.** The primary objective of this Special Provision is the training and advancement of minorities, women and economically disadvantaged persons toward journeyworker status. Accordingly, make every effort to enroll minority, women and economically disadvantaged persons to the extent that such persons are available within a reasonable area of recruitment. This training commitment is not intended, and shall not be used to discriminate against any applicant for training, whether or not he/she is a member of a minority group.
2. **Trainee Assignment.** Training assignments are determined based on the past contract volume of federal-aid work performed with the Department. Contractors meeting the selection criteria will be notified of their training assignment at the beginning of the reporting year by the Department's Office of Civil Rights.
3. **Program Requirements.** Fulfill all of the requirements of the On-the-Job Training Program including the maintenance of records and submittal of periodic reports documenting program performance. Trainees shall be paid at least 60% of the appropriate minimum journeyworker's rate specified in the contract for the first half of the training period, 75% for the third quarter and 90% for the last quarter, respectively. Contractors may be reimbursed \$0.80 per training hour at no additional cost to the Department.
4. **Compliance.** The DB Contractor will have fulfilled the contractual responsibilities by having provided acceptable training to the number of trainees specified in their goal assignment. Noncompliance may be cause for **corrective** and appropriate measures pursuant to Article 8.6., "Abandonment of Work or Default of Contract," which may be used to comply with the sanctions for noncompliance pursuant to 23 CFR Part 230.

EXHIBIT F

**AMENDMENTS, MODIFICATIONS AND SUPPLEMENTS TO
TXDOT STANDARD SPECIFICATIONS**

None

EXHIBIT G
PAYMENT CURVE

EXHIBIT H

CENTRAL TEXAS REGIONAL MOBILITY AUTHORITY
DBE POLICY STATEMENT

The Central Texas Regional Mobility Authority (the “Mobility Authority”) has established a Disadvantaged Business Enterprise (“DBE”) program in accordance with regulations of the U.S. Department of Transportation (“DOT”), 49 C.F.R. Part 26. The Mobility Authority has received, or will receive, federal financial assistance from DOT, and as a condition of receiving this assistance, the Mobility Authority has signed an assurance that it will comply with 49 C.F.R. Part 26.

It is the policy of the Mobility Authority to ensure that DBEs, as defined in 49 C.F.R. Part 26, have an equal opportunity to receive and participate in DOT-assisted contracts. It is also Mobility Authority policy:

1. to ensure nondiscrimination in the award and administration of DOT-assisted contracts;
2. to create a level playing field on which DBEs can compete fairly for DOT-assisted contracts;
3. to ensure that the DBE Program is narrowly tailored in accordance with applicable law;
4. to ensure that only firms that fully meet 49 C.F.R. Part 26 eligibility standards are permitted to participate as DBEs;
5. to help remove barriers to the participation of DBEs in DOT-assisted contracts; and
6. to assist the development of firms that can compete successfully in the market place outside the DBE Program.

Jeff Dailey, Deputy Executive Director, has been designated as the Mobility Authority DBE Liaison Officer. In that capacity, the Deputy Executive Director is responsible for implementing all aspects of the DBE program. Implementation of the DBE program is accorded the same priority as compliance with all other legal obligations incurred by the Mobility Authority in its financial assistance agreements with DOT.

The Mobility Authority has disseminated this policy statement to members of the Mobility Authority Board of Directors and all of the components of the regional mobility authority. The Mobility Authority has also distributed this statement to DBE and non-DBE business communities that perform work for us on DOT-assisted contracts. Such distribution was undertaken via publication on the Mobility Authority web site (www.mobilityauthority.com), by publication, and via reference in targeted mailings to DBE businesses in the Central Texas region.

Signed

Date

EXHIBIT I

FORM OF PERFORMANCE BOND

EXHIBIT I

FORM OF PERFORMANCE BOND

183 NORTH MOBILITY PROJECT DESIGN-BUILD CONTRACT

Bond No. _____

KNOW ALL PERSONS BY THESE PRESENTS, that the _____, a _____, as “Principal” and _____, as “Surety” or as “Co-Sureties”, each a corporation duly organized under the laws of the State indicated on the attached page, having its principal place of business at the address listed on the attached page, in the State indicated on the attached page, and authorized as a surety in the State of Texas, are hereby jointly and severally held and firmly bound unto the CENTRAL TEXAS REGIONAL MOBILITY AUTHORITY (the “Mobility Authority”), a political subdivision of the State of Texas, as “Obligee”, in the sum of [\$ _____] (the “Bonded Sum”), for the payment whereof Principal and Surety (or Co-Sureties), bind themselves, and their heirs, executors, administrators, representatives, successors, and assigns, jointly and severally, firmly by these presents.

WHEREAS, the Obligee, has awarded to Principal, a Design-Build Agreement for the 183 North Mobility Project, duly executed and delivered as of _____, 2020 (the “DB Agreement”), on the terms and conditions set forth therein; and

WHEREAS, upon issuance by the Obligee of NTP1, Principal is required to furnish a bond guaranteeing the faithful performance of its obligations under the Contract Documents;

NOW, THEREFORE, THE CONDITION OF THIS OBLIGATION IS SUCH THAT, if Principal shall promptly and faithfully perform all of its obligations under the Contract Documents, including any and all amendments and supplements thereto, then this obligation shall be null and void; otherwise it shall remain in full force and effect. The Obligee shall release this bond upon the occurrence of all of the conditions set forth in Section 9.2 of the DB Agreement.

The following terms and conditions shall apply with respect to this bond:

1. The Contract Documents are incorporated by reference herein.
2. This bond specifically guarantees the performance of each and every obligation of Principal under the Contract Documents, as they may be amended and supplemented, including but not limited to, its liability for liquidated damages as specified in the Contract Documents, but not to exceed the Bonded Sum.
3. The guarantees contained herein shall survive the final completion of the design and construction called for in the Contract Documents with respect to those obligations of Principal which survive such final completion; provided, however, that Principal’s warranty obligations shall be guaranteed by a different bond.
4. Whenever Principal shall be, and is declared by the Obligee to be, in default under the Contract Documents and the Obligee has formally terminated the Principal’s right to complete

the Design-Build Work, provided that the Obligee is not then in material default thereunder, Surety shall promptly take one of the following actions with the consent of the Obligee:

- a. arrange for the Principal to perform and complete the DB Agreement;
- b. complete the Project in accordance with the terms and conditions of the Contract Documents then in effect, through its agents or through independent contractors;
- c. obtain bids or negotiated proposals from qualified contractors acceptable to the Obligee for a contract for performance and completion of the Design-Build Work, arrange for a contract to be prepared for execution by the Obligee and the contractor selected with the Obligee's concurrence, to be secured with performance and payment bonds executed by a qualified surety equivalent to the bonds issued on the DB Agreement in an amount that corresponds to the amount of Design-Build Work to be completed, and pay to the Obligee the amount of damages as described in Paragraph 6 in excess of the unpaid balance of the Design-Build Price incurred by the Obligee resulting from the Principal's default; or
- d. waive its right to perform and complete, arrange for completion, or obtain a new contractor and with reasonable promptness under the circumstances, (i) after investigation, determine the amount for which it may be liable to the Obligee and, as soon as practicable after the amount is determined, tender payment therefore to the Obligee, or (ii) deny liability in whole or in part and notify the Obligee citing reasons therefore.

5. If Surety does not proceed as provided in Paragraph 4 with reasonable promptness, Surety shall be deemed to be in default on this Bond fifteen days after receipt of an additional written notice from the Obligee to Surety demanding that Surety perform its obligations under this Bond, and the Obligee shall be entitled to enforce any remedy available to the Obligee. If Surety proceeds as provided in Subparagraph 4.d, and the Obligee refuses the payment tendered or Surety has denied liability, in whole or in part, without further notice the Obligee shall be entitled to enforce any remedy available to the Obligee.

6. After the Obligee has terminated the Principal's right to complete the DB Agreement, and if Surety elects to act under Subparagraph 4.a, 4.b, or 4.c above, then the responsibilities of Surety to the Obligee shall not be greater than those of the Principal under the DB Agreement, and the responsibilities of the Obligee to Surety shall not be greater than those of the Obligee under the DB Agreement. To the limit of the Bonded Sum, but subject to commitment by the Obligee of the unpaid balance of the Design-Build Price to mitigation costs and damages on the DB Agreement, Surety is obligated without duplication for:

- a. the responsibilities of the Principal for correction of defective work and completion of the Design-Build Work;
- b. additional legal, design professional and delay costs resulting from Principal's default, and resulting from the actions or failure to act of Surety under Paragraph 4; and
- c. Liquidated Damages under the DB Agreement.

7. No alteration, modification or supplement to the Contract Documents or the nature of the work to be performed thereunder, including without limitation any extension of time for performance, shall in any way affect the obligations of Surety under this bond, provided that the aggregate dollar amount of Mobility Authority -Directed Changes, without Surety's prior written consent

thereto having been obtained, does not increase the Design-Build Price by more than \$ _____ [10% of the Contract Price]. Surety waives notice of any alteration, modification, supplement or extension of time other than Change Orders for Mobility Authority-Directed Changes in excess of such amount.

8. If Obligee fails to notify Surety of its intent to enforce Surety’s obligations hereunder within 730 days after an Event of Default under the Contract Documents and a formal termination of Principal’s right to complete the Design-Build Work, then this Performance Bond shall be null and void and Surety shall be released from any further obligations hereunder.

9. Correspondence or claims relating to this bond should be sent to Surety at the following address:

10. No right of action shall accrue on this bond to or for the use of any entity other than the Obligee or its successors and assigns.

11. If any legal action be filed on this bond, venue shall be in Travis County, Texas.

12. This bond is executed in accordance with the provisions of Chapter 2253 of the Texas Government Code, as amended.

13. Initially capitalized terms not otherwise defined herein shall have the definition set forth in Exhibit A of this DB Agreement.

IN WITNESS WHEREOF, Principal and Surety have caused this bond to be executed and delivered as of _____, 2020.

Principal:

By: _____
Its: _____
(Seal)

Surety:

By: _____
Its: _____
(Seal)

[ADD APPROPRIATE SURETY ACKNOWLEDGMENTS]

EXHIBIT J
FORM OF PAYMENT BOND

EXHIBIT J

FORM OF PAYMENT BOND

183 NORTH MOBILITY PROJECT DESIGN-BUILD AGREEMENT

Bond No. _____

KNOW ALL PERSONS BY THESE PRESENTS, that the _____, a _____, as “Principal” and _____, as “Surety” or as “Co-Sureties”, each a corporation duly organized under the laws of the State indicated on the attached page, having its principal place of business at the address listed on the attached page, in the State indicated on the attached page, and authorized as a surety in the State of Texas, are hereby jointly and severally held and firmly bound unto the CENTRAL TEXAS REGIONAL MOBILITY AUTHORITY (the “Mobility Authority”), a political subdivision of the State of Texas, as “Obligee”, in the sum of [\$ _____], (the “Bonded Sum”), for the payment whereof Principal and Surety or Co-Sureties, bind themselves, and their heirs, executors, administrators, representatives, successors, and assigns, jointly and severally, firmly by these presents.

WHEREAS, the Obligee, has awarded to Principal, a Design-Build Agreement for the 183 North Mobility Project, duly executed and delivered as of _____, 2020 (the “DB Agreement”), on the terms and conditions set forth therein; and

WHEREAS, upon issuance by Obligee of NTP1, Principal is required to furnish a bond guaranteeing payment of claims, subcontractors, suppliers, materialmen and mechanics.

NOW, THEREFORE, THE CONDITION OF THIS OBLIGATION IS SUCH THAT, if Principal shall fail to pay any valid and timely claims of subcontractors, suppliers, materialmen and mechanics with respect to the Design-Build Work, then Surety shall pay for the same in an amount not to exceed, in the aggregate, the Bonded Sum; otherwise this obligation shall be null and void upon the latest to occur of any of the events set forth in Section 9.3 of this DB Agreement.

The following terms and conditions shall apply with respect to this bond:

1. The Contract Documents are incorporated by reference herein.
2. No alteration, modification or supplement to the Contract Documents or the nature of the work to be performed thereunder, including without limitation any extension of time for performance, shall in any way affect the obligations of Surety under this bond, provided that the aggregate dollar amount of Mobility Authority -Directed Changes without Surety’s prior written consent thereto having been obtained, does not increase the Design-Build Price by more than \$ _____ [10% of the Design-Build Price]. Surety waives notice of any alteration, modification, supplement or extension of time other than Change Orders for Mobility Authority - Directed Changes in excess of such amount.

3. Correspondence or claims relating to this bond should be sent to Surety at the following address:

4. This bond shall inure to the benefit of the persons identified above so as to give a right of action to such persons and their assigns in any suit brought upon this bond.

5. To the extent permitted by law, the only permitted claimants under this Bond shall be those entities having a contract with Principal and those entities having a contract with an entity which has a contract with Principal.

6. If any legal action be filed on this bond, venue shall be in Travis County, Texas.

7. This bond is executed in accordance with the provisions of Chapter 2253 of the Texas Government Code, as amended.

8. Initially capitalized terms not otherwise defined herein shall have the definition set forth in Exhibit A of the DB Agreement.

IN WITNESS WHEREOF, Principal and Surety have caused this bond to be executed and delivered as of _____, 2020.

Principal:

By: _____
Its: _____
(Seal)

Surety:

By: _____
Its: _____
(Seal)

[ADD APPROPRIATE SURETY ACKNOWLEDGMENTS]

EXHIBIT K

FORM OF WARRANTY BOND

EXHIBIT K

FORM OF WARRANTY BOND

Bond No. _____

KNOW ALL PERSONS BY THESE PRESENTS, that the _____, a _____, as “Principal” and _____, as “Surety” or as “Co-Sureties”, each a corporation duly organized under the laws of the State indicated on the attached page, having its principal place of business at the address listed on the attached page, in the State indicated on the attached page, and authorized as a surety in the State of Texas, are hereby jointly and severally held and firmly bound unto the CENTRAL TEXAS REGIONAL MOBILITY AUTHORITY, a political subdivision of the State of Texas, as “Obligee”, in the sum of \$_____ (the “Bonded Sum”), for the payment whereof Principal and Surety (or Co-Sureties), bind themselves, and their heirs, executors, administrators, representatives, successors, and assigns, jointly and severally, firmly by these presents.

WHEREAS, Obligee, has awarded to Principal, a Design-Build Agreement for the 183 North Mobility Project, dated _____, 2020 (the “DB Agreement”), on the terms and conditions set forth therein; and

WHEREAS, Principal is required to furnish a bond guaranteeing the faithful performance of its warranty obligations under the Contract Documents after Final Acceptance, including payment of claims, subcontractors, suppliers, materialmen and mechanics, as a condition to release of the Performance Bond and Payment Bond with respect to the Project by Obligee.

NOW, THEREFORE, THE CONDITION OF THIS OBLIGATION IS SUCH THAT, if Principal shall promptly and faithfully perform all of its warranty obligations under the Contract Documents, as they may be amended or supplemented, including without limitation the fulfillment of all Warranties, environmental monitoring and landscaping obligations, and payment of claims, subcontractors, suppliers, materialmen and mechanics, then this obligation shall be null and void; otherwise this obligation shall remain in full force and effect, it being expressly understood and agreed that the liability of Surety for any and all claims hereunder shall in no event exceed the Bonded Sum.

The following terms and conditions shall apply with respect to this bond:

1. The Contract Documents are incorporated by reference herein.
2. Surety’s obligations under this Bond shall include the Principal’s obligation to pay its subcontractors, suppliers, materialmen and mechanics for warranty-related work or supplies.
3. The guarantees contained herein shall survive the final completion of the design and construction called for in the Contract Documents.

4. Whenever Principal shall fail to pay the lawful claims of any of the persons identified in item 2 above with respect to the Design-Build Work (which for purposes of this bond shall include all warranty work required to be performed pursuant to the Contract Documents), excluding Major Participants having an equity interest in Principal, then Surety shall pay for the same in an amount not to exceed the Bonded Sum.

5. Whenever Principal shall be, and is declared by the Obligee to be, in default with respect to its warranty obligations under the Contract Documents, provided that the Obligee is not then in material default thereunder, Surety shall promptly take one of the following actions with the consent of the Obligee:

a. arrange for Principal to perform and complete the warranty obligations of this DB Agreement;

b. complete the warranty-related work in accordance with the terms and conditions of the Contract Documents then in effect, through its agents or through independent contractors;

c. obtain bids or negotiated proposals from qualified contractors acceptable to the Obligee for a contract for performance and completion of the warranty-related work (as defined in the DB Agreement), through a procurement process approved by the Obligee, arrange for a contract to be prepared for execution by the Obligee and the contractor selected with the Obligee's concurrence, to be secured with performance and payment bonds executed by a qualified surety equivalent to the bonds issued on the DB Agreement; or

d. waive its right to perform and complete, arrange for completion, or obtain a new contractor and with reasonable promptness under the circumstances, (i) after investigation, determine the amount for which it may be liable to the Obligee and, as soon as practicable after the amount is determined, tender payment therefore to the Obligee, or (ii) deny liability in whole or in part and notify the Obligee citing reasons therefore.

6. If Surety does not proceed as provided in Paragraph 5 with reasonable promptness, Surety shall be deemed to be in default on this Bond fifteen days after receipt of an additional written notice from the Obligee to Surety demanding that Surety perform its obligations under this Bond, and the Obligee shall be entitled to enforce any remedy available to the Obligee. If Surety proceeds as provided in Subparagraph 5.d, and the Obligee refuses the payment tendered or Surety has denied liability, in whole or in part, without further notice the Obligee shall be entitled to enforce any remedy available to the Obligee.

7. After the Obligee has terminated the Principal's right to complete the DB Agreement, and if Surety elects to act under Subparagraph 5.a, 5.b, or 5.c above, then the responsibilities of Surety to the Obligee shall not be greater than those of the Principal under the DB Agreement, and the responsibilities of the Obligee to Surety shall not be greater than those of the Obligee under the DB Agreement. To the limit of the Bonded Sum, but subject to commitment of the unpaid balance of the Design-Build Price to mitigation costs and damages on the DB Agreement, Surety is obligated without duplication for:

a. the responsibilities of the Principal for correction of defective work;

b. actual damages, including additional legal, design professional and delay costs resulting from Principal’s default, and resulting from the actions or failure to act of Surety under Paragraph 5; and

c. Liquidated Damages under the DB Agreement.

8. No alteration, modification or supplement to the Warranty provisions of the Contract Documents or the nature of the work to be performed thereunder, including without limitation any extension of time for performance, shall in any way affect the obligations of Surety under this bond. Surety waives notice of any alteration, modification, supplement or extension of time.

9. Initially capitalized terms not otherwise defined herein shall have the definitions set forth in Exhibit A of this DB Agreement.

10. If any legal action be filed on this bond, venue shall be in Travis County, Texas.

IN WITNESS WHEREOF, Principal and Surety have caused this bond to be executed and delivered as of _____, 2020.

Principal:

By: _____

Its: _____

(Seal)

Surety:

By: _____

Its: _____

(Seal)

[ADD APPROPRIATE ACKNOWLEDGMENTS]

EXHIBIT L
DRAW REQUEST AND CERTIFICATES

Draw Request # _____

Date: _____
month/day/year

Central Texas Regional Mobility Authority
3300 Interstate 35 Frontage Rd #300
Austin, Texas 78705

Draw Request for Design-Build Work performed for the period: _____ to _____
month/day/year month/day/year

- A. Original Contract Amount
- B. Approved Change Order Amounts
- C. Revised Contract Amount
- D. Cumulative Amount Earned to Date
- E. Cumulative Amount of Previous Draw Requests
- F. Amount Qualified for Payment this Period (D-E)
- G. Total Deductions from Progress Payment
- H. Current Amount Due

\$0.00
\$0.00
\$0.00

Printed Name
D/B Contractor's Project Manager

Signature

month/day/year

Printed Name
Mobility Authority Project Engineer

Signature

month/day/year

Printed Name
Central Texas Regional
Mobility Authority

Signature

month/day/year

183 North Mobility Project

[DB Contractor Name]

Draw Request Number []

For the Period Ending [Date]

Construction Quality Assurance Manager Certification

I hereby certify that;

- Except as specifically noted in this certification, all Work, including that of Subcontractors, Suppliers, and fabricators, which is the subject of the Draw Request has been checked and/or inspected by the Construction Quality Control Team;
- Except as specifically noted in this certification, all Work which is the subject of the Draw Request conforms to the requirements of the Contract Documents, the Government Approvals and applicable Law;
- The Construction QMP and all of the measures and procedures provided therein are functioning properly and are being followed in all respects; and
- The construction percentages and costs indicated are accurate and correct.

Signature: _____ Date: _____
Construction Quality Assurance Manager

Print: _____

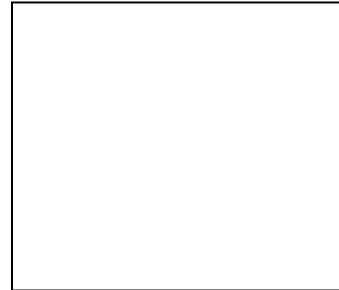

Certification Exceptions:

EXHIBIT M

FORM OF CHANGE ORDER FORM

CHANGE ORDER PROPOSAL NO. _____ **CONTRACT NO.** _____

SECTION I

Originator:

Date:

Title:

Contract No:

Company Name:

DESCRIPTION:

Scope:

CAUSE OF CHANGE ORDER REQUEST:

DB Contractor Project Manager

Date

**CHANGE ORDER
REQUEST**

CHANGE ORDER PROPOSAL NO. _____ **CONTRACT NO.** _____

SECTION II

The total amount of this Change Order is \$ _____. Documentation supporting the Change Order is attached as Exhibits _____ through _____.

Payment Schedule Items Added/Deducted:

<u>Activity No.</u>	<u>Description</u>	<u>Amount</u>
_____	_____	_____

Summary of Change Order Proposal by Categories: [Additives/(Credits)]

A.	Design-Builder Labor (construction)	
1.	Wages	\$ _____
2.	Labor benefits (55%)	\$ _____
B.	Design-Builder and Subcontractor Labor (professional services)	
1.	Wages (Raw)	\$ _____
2.	Labor benefits (145%, which includes overhead and profit)	\$ _____
3.	Off-duty peace officers and patrol cruisers	\$ _____
C.	Materials (with taxes, freight and discounts)	\$ _____
D.	Equipment	\$ _____
E.	Subcontracts (Time and Materials cost)	\$ _____
F.	Utility Direct Costs	\$ _____
G.	Overhead and Profit	
1.	Labor (25%)	\$ _____
2.	Materials (15%)	\$ _____
3.	Subcontracts (5%)	\$ _____
4.	Utility Direct Costs (5)	\$ _____
H.	Grand Total	\$ _____

**CHANGE ORDER
REQUEST**

CHANGE ORDER PROPOSAL NO. _____ CONTRACT NO. _____

SECTION III

The status of Substantial Completion is as follows:

- Unaffected by this Change Order Proposal
- Affected by (increasing) (decreasing) the scheduled date for achieving Substantial Completion by _____ calendar days.
- Affected by (increasing) (decreasing) the _____ Float by _____ calendar days.

The status of Final Acceptance is as follows:

- Unaffected by this Change Order Proposal
- Affected by (increasing) (decreasing) the scheduled date for achieving Final Acceptance by _____ calendar days.
- Affected by (increasing) (decreasing) the _____ Float by _____ calendar days.

Accordingly, the summary of the dates of Substantial Completion and Final Acceptance and Float are as follows:

1. Substantial Completion: _____
(+ or - _____ days from base of NTP 1)
2. Final Acceptance: _____
(+ or - _____ days from base of NTP 1)
3. Number of days of Project Float _____

Justification for Change Order with reference to Contract Documents:

The above three sections represent a true and complete summary of all aspects of this change.

This Change Order Proposal includes all known and anticipated impacts or amounts, direct, indirect and consequential, which may be incurred as a result of the event, occurrence or matter giving rise to the proposed change.

**CHANGE ORDER
REQUEST**

CHANGE ORDER PROPOSAL NO. _____ **CONTRACT NO.** _____

If the foregoing Change Order Proposal includes claims of Subcontractors or Suppliers, the undersigned have reviewed such claims and have determined in good faith that the claims are justified as to both entitlement and amount.

DB Contractor Project Manager **Date**

**CHANGE ORDER
REQUEST**

CHANGE ORDER PROPOSAL NO. _____ **CONTRACT NO.** _____

SECTION IV (Reviewed by Mobility Authority Representative)

Mobility Authority Representative

Date

Comments:

**CHANGE ORDER
REQUEST**

CHANGE ORDER PROPOSAL NO. _____ **CONTRACT NO.** _____

SECTION V (Reviewed by TxDOT Representative)

Date _____ **TxDOT Representative** _____

Comments:

**CHANGE ORDER
REQUEST**

CHANGE ORDER PROPOSAL NO. _____ **CONTRACT NO.** _____

SECTION VII (Approval by the Mobility Authority)

CHANGE ORDER ISSUED: Yes No

Date

Mobility Authority Executive Director

Comments:

EXHIBIT N

**INITIAL DESIGNATION OF
AUTHORIZED REPRESENTATIVES**

DB Contractor:

#

Mobility Authority:

Central Texas Regional Mobility Authority
3300 N. IH-35, Suite 300, Austin, Texas 78705
Attention: Mike Sexton, P.E.
Phone: 512-996-9778
Fax: 512-996-9784
e-mail: msexton@ctrma.org

EXHIBIT O

DB CONTRACTOR COMMITMENTS AND ATCs

To the extent provided in Section 1.2(c) of the DB Agreement (DBA), the GREAT HILLS CONSTRUCTORS Proposal shall be considered a part of this DBA. The following items identify the Mobility Authority's understanding of some specific commitments in the Project development.

A. Approved Alternative Technical Concepts and Value Added Concepts.

The following is a list of the Alternative Technical Concepts ("ATCs") that GREAT HILLS CONSTRUCTORS ("DB Contractor") indicated it was going to incorporate into the Design-Build Work ("DB Work") and Value Added Concepts ("VACs") that Mobility Authority hereby requests to be incorporated into the DB Work. A description of each such ATC and VAC is attached to this Exhibit O and incorporated herein. The Mobility Authority reserves the right to reject any ATC listed below that (a) does not satisfy the Mobility Authority's written conditions of pre-approval, if any; (b) is materially different from the ATC pre-approved by the Mobility Authority; or (c) requires design exceptions from FHWA and TxDOT which were not clearly identified and approved during the ATC pre-approval process and which FHWA and TxDOT will not approve. In the event the Mobility Authority rejects an ATC for any of the above reasons, the DB Contractor agrees that it will design and construct the Project in accordance with requirements of the Contract Documents, without an adjustment in Design-Build Price ("DB Price") or Completion Dates; provided, however, that DB Contractor may challenge the Mobility Authority's determination in accordance with the dispute resolution provisions of the DBA. In the event the Disputes Resolution Board determines that the Mobility Authority has wrongly rejected an ATC, DB Contractor shall be entitled to a Change Order to increase the DB Price and/or extend the Completion Deadline.

ATC – 02: Realignment of 183N-to-Loop 1 Direct Connector and Deferred Collector Distributor; subject to the conditions sent by the Mobility Authority through correspondence dated March 6, 2020.

ATC – 04: Southbound Loop 1 entrance ramp shift under Far West; subject to the conditions sent by the Mobility Authority through correspondence dated March 6, 2020.

ATC – 05: Alignment Shift between LP360 and MoPac; subject to the conditions sent by the Mobility Authority through correspondence dated March 6, 2020.

B. Additional Commitments From Technical Proposal.

1. DB Contractor will schedule initial partnering workshop within 30 days of NTP1. (PMP 4.3.3.2 (a)2 page 5)
2. DB Contractor will implement monthly (or a mutually agreed to frequency) partnering surveys to evaluate team performance on goals and objectives established during the initial partnering workshop and to identify new issues requiring attention. (PMP 4.3.3.2 (a)2 page 5)
3. Prior to initiating construction, QC and safety staff, designers, construction personnel, and the Mobility Authority conduct a pre-construction review of RFC plans for the purpose of gaining an understanding of work tasks and quality requirements. (PMP 4.3.3.2 (a)3 page 6)
4. DB Contractor's formal process for handling RFIs, NDCs, FDCs, and NCRs promptly notifies the Mobility Authority and field personnel of upcoming design changes. (PMP 4.3.3.2 (a)3 page 6)
5. Parsons will mobilize the necessary resources to fully support design and construction requirements. (PMP 4.3.3.2 (a)3 page 7)
6. Project Manager has full authority to represent the DB Contractor and provide all personnel, equipment, and financial resources to deliver the Project. (PMP 4.3.3.2 (a)3 page 7)
7. Subcontractors are fully integrated and held to the DB Contractor's Project safety, quality, and performance standards. (PMP 4.3.3.2 (a)3 page 7)
8. Management of subcontractors includes: 1- formal and informal partnering; 2- pre-activity meetings to discuss tasks, safety and quality expectations, and potential conflicts; 3- daily game plan meetings to confirm access and materials; 4- monthly meetings to review invoices and payments. (PMP 4.3.3.2 (a)3 page 7)
9. DB Contractor will involve Arun Verma, Project Scheduler, in all task team meetings to maintain a realistic schedule, unless otherwise agreed. (PMP 4.3.3.2 (a)3 page 8)
10. DQAM is not involved with scheduling or production activities and has full stop-work authority for quality-related issues. (PMP 4.3.3.2 (b) page 8)
11. CQAM will review all Project elements to verify and document that the DB Contractor constructs the Project in conformance with the RFC and ERFC plans, specifications, and approved working and shop drawings. (PMP 4.3.3.2 (b)1 page 9)

12. DB Contractor will hold kickoff meeting to review submittals and technical requirements. (PMP 4.3.3.2 (b)1 page 9)
13. As design progresses, issues will be presented for coordination between design, construction, and the Mobility Authority staff. (PMP 4.3.3.2 (b)1 page 9)
14. Prior to each milestone submittal, the DB Contractor's design task leads organize and direct Interdisciplinary Reviews (IDR) and detailed QC peer review of the plans, calculations, and reports. DB Contractor will back-check all design work, including plans, specifications, calculations, and reports. DB Contractor will control plan quality by stamping each document to indicate the reviewer and review date, using color coding to distinguish between comments, errors, and further changes needed. (PMP 4.3.3.2 (b)1 page 9)
15. Design Manager, and task leaders will lead Interdisciplinary Reviews where all other disciplines including Environmental Compliance Manager, will review the plans. (PMP 4.3.3.2 (b)1 page 9)
16. Design Manager enforces the use of the design management plan and tools for the Project. (PMP 4.3.3.2 (b)1 page 10)
17. Design Manager and appropriate staff from the DB Contractor will attend comment resolution meetings, which include design task leads, construction staff, and the Environmental Compliance Manager. (PMP 4.3.3.2 (b)1 page 10)
18. Design, construction, and the Mobility Authority to mutually agree on schedule, design deliverables, and submittal process. (PMP 4.3.3.2 (b)3 page 11)
19. DB Contractor will identify and track necessary QC/QA and permitting work that must be performed prior to milestone submittals or construction in the project schedule. (PMP 4.3.3.2 (b)3 page 11)
20. DB Contractor and subcontractors will use the same discipline specific QC checklists. (PMP 4.3.3.2 (b)3 page 11)
21. Electronic comments will be available in real time. (PMP 4.3.3.2 (b)3 page 11)
22. DB Contractor will perform periodic, internal, formal quality audits to ensure compliance with Project CADD Standards. (PMP 4.3.3.2 (b)3 page 13)
23. DB Contractor will invite the Mobility Authority's maintenance personnel to task team meetings to identify and resolve maintenance issues prior to RFC. The Mobility Authority maintenance personnel will interface with design to focus on items such as preferred materials and equipment, maintenance accessibility, slope paving in areas that are not easily accessed, and pavement structure. (PMP 4.3.3.2 (b)3 page 13)
24. Direct Connector bridges shall use all concrete beams. (PMP 4.3.3.2 (b)3 page 13)

25. Management of Construction consists of: (PMP 4.3.3.2 (b)4 page 13)
 - Measure Performance: Constantly monitor safety and quality, and consistently monitor budget and schedule performance
 - Continuously Improve: Frequently communicate successes and failures and apply lessons learned
26. DB Contractor will develop schedule to minimize impacts on the environment, communities, and the traveling public, while optimizing construction performance. (PMP 4.3.3.2 (b)4 page 14)
27. DB Contractor partners and collaborates with identified Project stakeholders to ensure local businesses, first responders, schools, and the traveling public are notified so they know what to expect as work progresses. (PMP 4.3.3.2 (b)4 page 14)
28. When construction begins, DB Contractor will hold weekly (or a mutually agreed to frequency) MOT coordination meetings and invite and encourage stakeholders to attend. (PMP 4.3.3.2 (b)4 page 14)
29. Partner the Design Manager with the Construction Manager, and each design discipline with a construction superintendent, or designated construction personnel to streamline and maintain continuity of coordination. (PMP 4.3.3.2 (b)4 page 17)
30. Utilize design charettes or other best practices as needed to collaboratively work through solutions to design issues. (PMP 4.3.3.2 (b)4 page 17)
31. Clearly designate work limits and existing features not to be disturbed, using means determined by DB Contractor. (PMP 4.3.3.2 (b)4 page 17)
32. Implement only the Mobility Authority-, TxDOT-, and city-approved detours. (PMP 4.3.3.2 (b)4 page 17)
33. Require work areas to be inspected, cleaned, and organized daily. (PMP 4.3.3.2 (b)4 page 17)
34. Maintain construction exits and sweep impacted. (PMP 4.3.3.2 (b)4 page 17)
35. DB Contractor will schedule as reasonably practicable and in coordination with the Mobility Authority, work around the needs of the property owners to allow access. (PMP 4.3.3.2 (b)4 page 18)
36. Identify unsuitable pavement subbase materials and either undercutting and replacing poor materials to the required depth or stabilizing the subbase using hydrated lime, or other methods coordinated with the Mobility Authority. (PMP 4.3.3.2 (b)4 page 20)

37. Where necessary, upgrade the quality of fill material in outside widening regions or increase compaction requirements to eliminate differential settlement between existing and new pavements. (PMP 4.3.3.2 (b)4 page 20)
38. DB Contractor's Safety Manager and his team lead a safety orientation for all employees prior to starting work. In addition to safety information, this orientation includes environmental compliance training. (PMP 4.3.3.2 (b)6 page 21)
39. All foreman and above will maintain the following minimum safety training: (PMP 4.3.3.2 (b)6 page 22)
 - OSHA 30: Current within 8 years
 - START: Current within 4 years
 - Crane Awareness: Current within 4 years
 - CPR: Current within 2 years
40. Safety representatives are on duty at all times work is occurring. (PMP 4.3.3.2 (b)6 page 22)
41. DB Contractor will coordinate upcoming submittals, milestones, and schedule changes through three-week look-ahead schedules and owner coordination meetings. (PMP 4.3.3.2 (c)4 page 25)
42. DB Contractor will keep reviewing agencies up to date on the design schedule so resources can be planned and allocated appropriately. DB Contractor will invite these stakeholders as appropriate or as directed by the Mobility Authority to weekly task team meetings, over the shoulder reviews, and In-Progress Design Workshops so they can be involved in the design decision-making process and aware of issues. (PMP 4.3.3.2 (c)4 page 25)
43. Subcontractors will be contractually required to attend daily and weekly schedule meetings, when working on the Project, to provide accurate progress updates for incorporation into the Project. (PMP 4.3.3.2 (c)5 page 25)
44. DB Contractor will transparently identify the root cause of issues, propose potential solutions to work with the Mobility Authority to adopt the best viable solution. (PMP 4.3.3.2 (c)7 page 26)
45. DB Contractor's Project Scheduler will update the schedule weekly to proactively monitor progress and identify potential issues. (PMP 4.3.3.2 (c)9 page 27)
46. DB Contractor will create a detailed weekly work plan to identify the scope of work to be completed and the resources, labor, and equipment needed to complete it. (PMP 4.3.3.2 (c)9 page 27)
47. DB Contractor will implement a combined schedule and cost control dashboard to provide customizable reports to project staff and the Mobility Authority, providing snapshot views of progress. (PMP 4.3.3.2 (c)9 page 27)

48. DB Contractor will establish milestones for each design, permit, and agreement submittal and regularly tracks and monitors relocation progress. (Development Plan (DP) 4.3.3.3 (a)1 page 1)
49. DB Contractor will update the concept plan as relocation designs progress to better manage relocations. (DP 4.3.3.3 (a)2 page 3)
50. DB Contractor coordinates with the Mobility Authority and TxDOT to identify any new proposed installations (Utility Installation Review permits) to confirm installation does not impact proposed improvements. (DP 4.3.3.3 (a)2 page 3)
51. Before starting construction adjacent to utilities, DB Contractor will field verify utility locations by methods including potholing or hand excavation, or other DB Contractor required means. (DP 4.3.3.3 (a)3 page 4)
52. DB Contractor will verify perpendicular utilities at each potential conflict point, such as sidewalk excavation, retaining walls, drainage, and all drilled shafts. (DP 4.3.3.3 (a)3 page 4)
53. DB Contractor will employ precise engineering by modeling three-dimensional utility data versus proposed roadway features in a process called 3D Clash Detection as necessary or mutually agreed. (DP 4.3.3.3 (a)3 page 4)
54. DB Contractor will adapt the Utility Tracking Report and Utility Adjustment Concept Plan into the GIS application to track the status of utility conflicts from initial conflict evaluation through SUE field work, design, permitting, agreement approvals, material procurement, construction, and invoicing all the way to final closeout. (DP 4.3.3.3 (a)3 page 5)
55. During the design phase, DB Contractor collaborates with each utility owner to confirm they are made whole with any required utility adjustments, including items deemed as non-betterment in the DBA, Exhibit A. (DP 4.3.3.3 (a)5 page 6)
56. DB Contractor will be transparent with information and fosters cooperation with utility owners to identify elective betterments early, advance early discussions to define scope, budget, schedule and design, and confirm each betterment is correctly accounted for in the UAA. Then DB Contractor will incorporate proposed betterment scopes into the Project schedule. (DP 4.3.3.3 (a)5 page 6)
57. DB Contractor conducts weekly construction update meetings, unless otherwise approved by the Mobility Authority, with all utility owners to discuss planned construction activities for the next three to nine weeks using look-ahead schedules and any critical path utility relocations. DB Contractor will document these meetings and distribute action items to all attendees. (DP 4.3.3.3 (a)6 page 6)
58. If GHC identifies a new utility easement as the Project develops, our ROW Manager or designated person with ROW subcontractor, works collaboratively

- with the design team and the Project Scheduler to identify potential impacts to the schedule and determine a mitigation plan. (DP 4.3.3.3 (a)10 page 9)
59. Independent ECM and the members of the environmental team will be integrated into the Interdisciplinary Review process for each design submittal to ensure all plans comply with environmental laws, rules, permits, or other commitments. (DP 4.3.3.3 (b)1 page 9)
 60. If crash frequency increases in a particular phase, DB Contractor will review and update traffic control plan as needed to reduce crash potential. (DP 4.3.3.3 (b)2 page 10)
 61. No one begins work activities on the jobsite without completing the environmental training. (DP 4.3.3.3 (b)5 page 12)
 62. Each worker is required to attend a one-hour karst discovery and mitigation training before performing any work. The environmental team documents all introductory and ongoing training and submits a monthly report to the Mobility Authority. (DP 4.3.3.3 (b)5 page 12)
 63. All construction personnel are made aware of environmentally sensitive areas through the training program. (DP 4.3.3.3 (b)7 page 13)
 64. DB Contractor trains each employee about how to properly identify and respond upon encountering hazardous material to keep everyone safe. (DP 4.3.3.3 (b)8 page 13)
 65. DB Contractor will evaluate pipe outlets for adequate velocities, erosion protection, and energy dissipation. New or upgraded headwalls, safety aprons, and end treatments are also considered where needed. (DP 4.3.3.3 (c)1 page 16)
 66. In Water Quality Basins A and B, DB Contractor will uncover existing enclosed box culverts and create open-air chambers by extending box walls to ground level, allowing for maintenance access. When near existing MSE walls, DB Contractor will perform more complex box modifications, which may include small diameter drilled shaft installation to protect the integrity of the existing MSE while extending the wall height of the water quality basin. (DP 4.3.3.3 (c)2 page 18)
 67. DB Contractor constructs and upgrades new and existing permanent water quality and detention basins. (DP 4.3.3.3 (c)5 page 20)
 68. DB Contractor will upgrade or replace erosion control measures at pipe outlets prior to construction operations to reduce potential for pollution reaching downstream watershed areas. (DP 4.3.3.3 (c)5 page 20)

69. DB Contractor's design of driveways and sidewalks avoids adverse impacts to drainage and parking facilities not identified in existing environmental documents. (DP 4.3.3.3 (d)5 page 23)
70. DB Contractor's Next Generation Concrete Surface treatment approach minimizes lane closures and does not place temporary markings on final grooved surfaces. (DP 4.3.3.3 (f)1 page 28)
71. In Segment 1 Phase 2, DB Contractor provides four continuous lanes of travel in each direction where the existing configuration only has three lanes. (DP 4.3.3.3 (f)2 page 30)
72. DB Contractor provides a haul route that is separate from US 183 traffic in both phases, by accessing traffic on the crossroads and greatly reducing the number of freeway access points. (DP 4.3.3.3 (f)3 page 31)
73. DB Contractor will develop a Toll Installation Dependency Matrix to identify specific infrastructure that must be in place before SI can begin installation and testing activities. DB Contractor will integrate the SI's Toll Collection System implementation into the Project schedule. (DP 4.3.3.3 (g)1 page 35)
74. DB Contractor's schedule accounts for toll system installation, testing, and remediation in case of test failures. (DP 4.3.3.3 (g)2 page 35)
75. DB Contractor will provide a Tolling System Infrastructure and SI Coordination Manager to track and coordinate toll infrastructure installation activities and schedules. (DP 4.3.3.3 (g)2 page 36)
76. For video transport and bi-directional camera control commands between the CCTV cameras and the TxDOT Traffic Management Center (TMC), DB Contractor will employ a high-bandwidth, Ethernet radio system. DB Contractor will install an ethernet switch and radio/antenna system atop each ITS pole with line-of-sight to the next ITS pole. At each end of the wireless network, the wireless signal converts to fiber optic cable- based media and transmits to the nearest communication hub at each end of the Project. This allows connectivity to the existing TxDOT network. DB Contractor will provide VMS data communications through cellular modem, transmitted over cellular network to the TMC. (DP 4.3.3.3 (g)3 page 36)
77. DB Contractor will communicate with property owners and determine contractor work schedules that provide access and minimize impacts to their operations. (DP 4.3.3.3 (h)4 page 38)
78. For locations with a single driveway, DB Contractor will schedule work activities outside their business hours. (DP 4.3.3.3 (h)4 page 38)

79. If properties must remain open at all times, DB Contractor will provide either a temporary access point or perform driveway work using partial width construction. (DP 4.3.3.3 (h)4 page 38)
80. For properties with multiple driveways, DB Contractor will allow for access to the property as needed by the property owner. (DP 4.3.3.3 (h)4 page 38)
81. DB Contractor will regularly include the Mobility Authority in progress, planning, and decision-making meetings to foster a “no surprises” approach in delivering the Project. (DP 4.3.3.3 (i)2 page 40)
82. DB Contractor will expand this collaborative environment to agencies and stakeholders, most notably the City of Austin, TxDOT and TCEQ. DB Contractor will work with key staff through regular coordination meetings and pre-submittal meetings for scopes of work subject to stakeholder agency review and approval. (DP 4.3.3.3 (i)2 page 40)
83. DB Contractor will document and share all forms of Project documents (meeting agendas and minutes, plan review comment resolutions, permitting documents, design and construction documents) through our document management platform to keep DB Contractor and the Mobility Authority informed and working together. (DP 4.3.3.3 (i)2 page 40)

EXHIBIT P

DEBARMENT CERTIFICATE

1. Questions

The DB Contractor shall respond either “yes” or “no” to each of the following questions. If DB Contractor's response is “yes” to any question(s), a detailed explanation of the circumstances shall be provided in the space following the questions. The DB Contractor shall attach additional documentation as necessary to fully explain said circumstances. With respect to the DB Contractor, the term “**affiliate**” shall mean (1) any other organization that is under common ownership with the DB Contractor; and (2) any equity owner. For purposes of this definition the term “any significant non-equity member” means someone who does not have capital contribution or buy-in and does not vote on all matters except compensation of equity partners.

2. Has the DB Contractor, including any of its affiliates, presently or since January 1, 2020 been:

- a. Debarred, declared ineligible, or voluntarily excluded from covered transactions by any federal, state, or local entity.

If yes, please provide a list and a brief description (including state and county). If no, so state.

Yes ___ No ___

- b. Convicted of or had a civil judgment rendered against them for commission of fraud or a criminal offense in connection with obtaining, attempting to obtain, or performing a federal, state, or local transaction or contract.

If yes, please provide a list and a brief description (including state and county). If no, so state.

Yes ___ No ___

- c. Found to be in violation of federal or state antitrust statutes.

If yes, please provide a list and a brief description (including state and county). If no, so state.

Yes ___ No ___

- d. Convicted of or indicted for or otherwise criminally charged by a government entity (state, federal or local) with commission of embezzlement, theft, forgery, bribery, falsification or destruction of records, marking false statements or receiving stolen property.

If yes, please provide a list and a brief description (including state and county). If no, so state.

Yes ___ No ___

- e. The subject of contract termination with a federal, state, or local entity for cause or default.

If yes, please provide a list and a brief description (including state and county). If no, so state.

Yes ___ No ___

- f. Been convicted of or charged (criminally or civilly) with any violation of (1) any applicable anti-money laundering laws, including those contained in the Bank Secrecy Act of 1970, as amended, and the regulations promulgated thereunder; (2) any applicable economic sanction laws administered by the Office of Foreign Assets Control of the United States Treasury (OFAC) or the United States Department of State; or (3) any applicable anti-drug trafficking, anti-terrorism, or anti-corruption laws, civil or criminal.

If yes, please provide a list and a brief description. If no, so state.

Yes ___ No ___

- g. Been (1) named on the list of "Special Designated Nationals or Blocked Persons" maintained by OFAC or any similar list maintained by the United States Department of State, or (2) convicted of or charged with a violation of any obligation to maintain appropriate controls as required by applicable governing laws of your jurisdiction as are necessary to ensure compliance with the economic sanctions, laundering and anticorruption laws of the United States and the jurisdiction where you reside, are domiciled or have your principal place of business.

If yes, please provide a list and a brief description. If no, so state.

Yes ___ No ___

[DB CONTRACTOR]

By: _____
Name: _____
Title: _____

EXHIBIT Q

Noncompliance Charges Provisions

FOR

DEVELOPMENT OF THE

183 NORTH MOBILITY PROJECT

THROUGH A DESIGN-BUILD AGREEMENT

PROJECT NUMBER: 20183N22701C



BY THE

CENTRAL TEXAS REGIONAL MOBILITY AUTHORITY

EXECUTION COPY

DESIGN-BUILD AGREEMENT - EXHIBIT Q

NONCOMPLIANCE CHARGES PROVISIONS

1. Noncompliance Charges System

1.1 Certain of the DB Contractor's failures to perform and breaches of its contractual obligations under the Contract Documents constitute Noncompliance Events (NCEs) that may result in the assessment of Noncompliance Charges. The Noncompliance Events Table in this Exhibit Q identifies each NCE, the charges assessed per event and the "NCE Cure Period" available to the DB Contractor for each NCE (the "**Noncompliance Events Table**"). Noncompliance Charges are a system to measure the DB Contractor's performance and trigger the remedies set forth or referenced in this Exhibit Q.

1.2 [RESERVED]

1.3 The inclusion in the Noncompliance Events Table of a breach or failure to perform bears no implication as to whether such breach or failure to perform constitutes a material breach.

2. Assessment Notification and Cure Process

2.1 Electronic Database and Notification Initiated by Mobility Authority

2.1.1 The Mobility Authority will provide an electronic database for administration of the Noncompliance Charges system under this Exhibit Q. Upon discovery of any NCE specified in the Noncompliance Events Table, the Mobility Authority may enter the items described in this Section 2.1.1 pertaining to the NCE into the electronic database. The Mobility Authority shall notify the DB Contractor of any NCE entered into the electronic database. The electronic database will:

- (a) Include a description of the NCE in reasonable detail;
- (b) Identify the reference number and headings and sub-headings assigned to the NCE in the Noncompliance Events Table;
- (c) Identify the location, date and time identified;
- (d) Indicate the applicable NCE Cure Period as set forth in the Noncompliance Events Table;
- (e) Indicate status of cure, whether the item is open, cured (entered by the DB Contractor), verified and closed (entered by the Mobility Authority), rejected (entered by the Mobility Authority), or disputed (entered by the DB Contractor);
- (f) Indicate the date and time of cure;
- (g) Provide either as an attachment or as a cite, documentation otherwise submitted to the Mobility Authority of the cure; and
- (h) Provide such other information as may be required by the electronic database.

2.1.2 If the DB Contractor disagrees with the Mobility Authority entries, the changes or entries inserted by the Mobility Authority must remain in place, subject to the provisions regarding dispute resolution in Section 25 of the DB Agreement.

2.1.3 The Mobility Authority reserves the right at any time to modify the format and design of the electronic database.

2.1.4 Each Draw Request submitted to the Mobility Authority pursuant to Section 13.3 of the DB Agreement shall include a report of all NCEs occurring during the preceding month and on the Project to date. The Draw Request shall (a) include all pertinent information about all NCEs for the applicable period, (b) identify for each NCE for which a cure is available, whether the cure has occurred, whether the Mobility Authority has certified acceptance of cure, and (c) if any NCE is in dispute, identify the anticipated date of its resolution.

2.2 NCE Cure Periods

2.2.1 The DB Contractor shall cure each NCE by the end of the NCE Cure Period for each such NCE set forth in the Noncompliance Events Table.

2.2.2 The NCE Cure Periods set forth in the Noncompliance Events Table shall be the only cure period for the DB Contractor applicable to the NCEs.

2.3 Notification of Cure

2.3.1 When the DB Contractor determines that it has completed cure of any NCE, the DB Contractor shall notify the Mobility Authority that it has completed the cure. This shall serve as the DB Contractor's notice of cure to the Mobility Authority.

2.3.2 Upon the DB Contractor's determination that it has completed the cure, the Mobility Authority shall verify that the NCE has been cured and shall certify its satisfaction via the electronic database.

2.3.3 Thereafter, the Mobility Authority shall have the right to inspect to verify completion of the cure. If satisfied that the NCE is fully cured, the Mobility Authority shall deliver to the DB Contractor a Notice of Determination with its acceptance or rejection of the cure in writing within seven (7) days of receipt of the DB Contractor's notice of cure. If the Mobility Authority issues a Notice of Determination with its acceptance of a cure, the cure is effective as of the date of the DB Contractor's notice of cure described in this Section 2.

2.3.4 Subject to the time restrictions in this Section 2, the Mobility Authority may reject the DB Contractor's notice of cure if the Mobility Authority determines that the DB Contractor has not fully cured the NCE or if the Mobility Authority cannot determine if the DB Contractor has fully cured the NCE. Upon making this determination, the Mobility Authority shall deliver a Notice of Determination to the DB Contractor rejecting the cure in writing. Any dispute regarding rejection of cure shall be resolved per the dispute resolution procedures set forth in this DB Agreement.

3. Assessment of Noncompliance Charges

The Mobility Authority may assess Noncompliance Charges in accordance with the Noncompliance Events Table, subject to the following:

(a) For each NCE for which an NCE Cure Period is identified in the Noncompliance Events Table that has not been cured, Noncompliance Charges shall first be assessed at the end of the first NCE Cure Period.

(b) For each NCE for which an NCE Cure Period is identified in the Noncompliance Events Table that is a late, incomplete, or defective submittal, Noncompliance Charges shall first be assessed at the date of expiration of the time period or milestone event required by the Contract Documents for the submittal.

(c) If a Noncompliance Event for which an NCE Cure Period is provided in the Noncompliance Events Table is not fully cured and verified by the Mobility Authority within the applicable NCE Cure Period then, without necessity for further notice, additional Noncompliance Charges shall be assessed against the DB Contractor for each day that continuation of such Noncompliance Event beyond such NCE Cure Period occurs, with the exception of Noncompliance Event Ref. No. 8h which will be subject to assessment of additional Noncompliance Charges for each hour that continuation of such Noncompliance Event beyond the NCE Cure Period occurs. Such additional Noncompliance Charges shall be assessed against the DB Contractor in accordance with Section 7 and deducted from the applicable periodic payment by the Mobility Authority in accordance with Section 13.3.11 of the DB Agreement.

4. [RESERVED]

5. Special Provisions for Certain Noncompliance Events

5.1 The provisions of this Section 5 apply to a Noncompliance Event identified in the Noncompliance Events Table that is directly attributable to a Force Majeure Event.

5.2 If any such NCE occurs, then:

(a) The applicable NCE Cure Period for any such NCE shall be extended if such NCE is not reasonably capable of being cured within the applicable NCE Cure Period solely due to the occurrence of such Force Majeure Event. The extension shall be for a reasonable period of time under the circumstances, taking into account the scope of the efforts necessary to cure, the effect of the Force Majeure Event on the DB Contractor's ability to cure, availability of temporary remedial measures, and the need for rapid action due to impact of the NCE on safety or traffic movement; and

(b) In respect of such NCE, no Noncompliance Charges shall be assessed, nor result in Noncompliance Charges under Section 7; provided, however, that the NCE is cured within the applicable NCE Cure Period, as it may be extended pursuant to Section 5.2(a):

5.3 For the avoidance of doubt, for any NCE directly attributable to a Force Majeure Event where the DB Contractor is unable to comply with a requirement of the Contract Documents due to an ongoing Force Majeure Event, then solely during the period that such Force Majeure Event prevents compliance with such requirement, no Noncompliance Charges will be assessed for such NCE and the DB Contractor shall be excused from performance of the underlying requirement.

6. Provisions Regarding Dispute Resolution

6.1 The DB Contractor may object to the assessment of Noncompliance Charges or the starting point for or duration of the NCE Cure Period respecting any NCE by delivering to the Mobility Authority notice of such objection not later than two days after the Mobility Authority delivers its Notice of Determination.

6.2 The DB Contractor may object to the Mobility Authority's rejection of any certification of completion of a cure given pursuant to Section 2 by delivering to the Mobility Authority notice of such objection not later than two (2) days after the Mobility Authority delivers its notice of rejection.

6.3 If for any reason the DB Contractor fails to deliver its notice of objection within the applicable time period, the DB Contractor shall be conclusively deemed to have accepted the matters set forth in the applicable notice, and shall be forever barred from challenging them.

6.4 If the DB Contractor gives timely notice of objection and the Parties are unable to reach agreement on any matter in dispute within ten (10) days of such objection, either Party may refer the matter for resolution according to the procedures for resolving disputes in the DB Agreement.

7. Application of Noncompliance Charges

7.1 Upon assessment of Noncompliance Charges pursuant to Section 3, the Mobility Authority shall be entitled to immediate and automatic Noncompliance Charges from the DB Contractor.

7.2 Notwithstanding the above, upon achievement of Substantial Completion and until Final Acceptance, any remaining or newly assessed Noncompliance Charges shall be deducted from payments, in accordance with Section 13.3.11 of the DB Agreement.

7.3 The DB Contractor acknowledges that the Noncompliance Charges assessed in accordance with the Contract Documents are reasonable liquidated amounts in order to compensate the Mobility Authority for damages it will incur by reason of the DB Contractor's failure to comply with the availability and performance standards. The damages addressed by the Noncompliance Charges include: (a) the Mobility Authority's increased costs of administering this DB Agreement, including the increased costs of engineering, legal, public involvement, accounting, monitoring, oversight and overhead, and could also include obligations to pay or reimburse Governmental Entities with regulatory jurisdiction for violation of applicable Governmental Approvals or for their increased costs of monitoring and enforcing the DB Contractor's compliance with applicable Governmental Approvals; (b) potential harm and future costs to the Mobility Authority from premature reduction in the condition of the facilities; (c) potential harm to the credibility and reputation of the Mobility Authority with other Governmental Entities, with policy makers and with the general public who depend on and expect timely and quality delivery and availability of service; (d) potential harm and detriment to Project users, which may include loss of use, enjoyment and benefit of the facilities, additional wear and tear on vehicles, and increased costs of congestion, travel time and accidents; and (e) the Mobility Authority's increased costs of addressing potential harm to the environment, including increased harm to air quality caused by congestion, and harm to water quality, soils conditions, historic structures and other environmental resources caused by NCEs.

7.4 The DB Contractor further acknowledges that these damages would be difficult and impracticable to measure and prove, because, among other things: (a) the Project is of a unique nature and

no substitute for it is available; (b) the costs of monitoring and oversight prior to increases in the level thereof will be variable and extremely difficult to quantify; (c) the nature and level of increased monitoring and oversight will be variable depending on the circumstances; and (d) the variety of factors that influence use of and demand for the Project make it difficult to sort out causation of the matters that will trigger these liquidated damages and to quantify actual damages.

8. Remedial Plan Delivery and Implementation

8.1 The DB Contractor recognizes and acknowledges that a pattern or practice of continuing, repeated or numerous NCEs, whether such NCEs are cured or not, will undermine the confidence and trust essential to the success of this DB Agreement and will have a material, cumulative adverse impact on the value of this DB Agreement to the Mobility Authority. The DB Contractor acknowledges and agrees that measures for determining the existence of such a pattern or practice described in this Exhibit Q is a fair and appropriate objective basis to conclude that such a pattern or practice will continue.

8.2 Upon the occurrence of twenty (20) NCEs within any six month period, the DB Contractor shall, within twenty (20) days after notice of such occurrence, prepare and submit a remedial plan for the Mobility Authority approval. The remedial plan shall set forth a schedule and specific actions to be taken by the DB Contractor to improve its performance. The Mobility Authority may require that such actions include improving the DB Contractor's quality management practices, plans and procedures, revising and restating applicable management plans, changing organizational and management structure, increasing monitoring and inspections, changing Key Personnel and other important personnel, replacement of Subcontractors, and delivering security to the Mobility Authority. For the avoidance of doubt, the achievement by the DB Contractor of the requirements set forth above shall not relieve the DB Contractor from the obligation to submit and act upon a remedial plan.

NONCOMPLIANCE EVENTS TABLE

Ref No.	Heading	Failure to:	NCE Cure Period	Noncompliance Charge
1	Key Personnel	Meet the requirements for Category A Key Personnel set forth in the Contract Documents, including <u>Section 3.6.3</u> and <u>Section 19.1</u> of the DB Agreement.	1 Day	\$2,000
2	Key Personnel	Meet the qualifications requirements for Category B Key Personnel set forth in the Contract Documents, including Technical Provision 1.1.3.2.	1 Day	\$1,000
2	QA/QC Submittals	Maintain and submit reports and results as required by <u>Technical Provision 2.0</u> .	2 Days	\$500
3	Project Management Plan	Have the relevant part of the Project Management Plan approved by the Mobility Authority prior to commencement of any Work governed by that portion of the Project Management Plan, or failure to comply, or cause a Subcontractor to comply, with a requirement, process, or procedure in the Project Management Plan, as required by the Contract Documents, including <u>Section 3.6</u> of the DB Agreement.	5 Days	\$1,000
4	Community Relations Program	Comply with the requirement of the Community Relations Program as set forth in <u>Technical Provision 4</u> .	2 Days	\$5,000
5	Comply with Progress Meetings	Comply with the requirements for any Project meeting, including for meeting attendance, proper issuance of an agenda, draft or final meeting minutes, or to accurately integrate the Mobility Authority's comments with the meeting minutes, including the requirements set forth in <u>Technical Provision 1</u> .	1 Day	\$500
6	DB Contractor Reporting Requirements	Comply with any of the reporting, recording keeping, or documentation requirements, including quality reporting requirements, monthly and annual reporting, or any Subcontractor reporting requirements, as required by and in accordance with the Contract Documents, including <u>Section 26.3</u> of the DB Agreement.	1 Day	\$1,000
8a-8h	Maintenance	Comply with maintenance requirements of <u>Technical Provision 24</u> for items 8a-8h set forth below:		
8a	Maintenance	Address Barricade Inspection Checklist (Form 599) items each month.	5 Days	\$5,000

Ref No.	Heading	Failure to:	NCE Cure Period	Noncompliance Charge
8b	Maintenance	Roadway Housekeeping – Keep Roadway and Shoulders swept utilizing Rotary Brooms and Vacuum Brooms.	1 Day	\$2,000
8c	Maintenance	Keep construction barrels free from dirt and maintain reflectivity.	3 Days	\$2,000
8d	Maintenance	Repair illumination.	2 Days	\$1,000
8e	Maintenance	Repair/Refresh Work Zone pavement markings.	5 Days	\$5,000
8f	Maintenance	Perform mowing and trash/litter collection in accordance with Technical Provision 24.	5 Days	\$5,000
8g	Maintenance	Graffiti Removal.	1 Day	\$2,000
8h	Maintenance	Perform emergency pavement repairs as required for safety of travelling public (i.e. non-repair will result in vehicle damage or injury).	4 Hour ¹	\$10,000
9	Safety and Incident Management	Comply with a requirement in respect of the Safety Plan and incident management plan as required by and in accordance with <i>Technical Provision 25</i> .	1 Day	\$5,000
10	Traffic Control Construction Requirements	Comply with Technical Provision 22 prior to implementing a traffic shift. Provide signed and sealed MOT plans, or signed and sealed redline revisions to MOT plans prior to walk-through events to traffic shifts. Provide any required VISSIM models to the Mobility Authority 10 Days prior to the traffic shift.	1 Day ²	\$10,000

1. The DB Contractor may make asphalt cold mix repairs in this case. The DB Contractor will coordinate with the Mobility Authority for timing of a hot mix repair.

2. The Mobility Authority's intent with respect to this requirement is well-planned traffic shifts.

29.20 Entire Agreement

The Contract Documents constitute the entire and exclusive agreement between the Parties relating to the specific matters covered herein and therein. All prior or contemporaneous oral or written agreements, understandings, representations and/or practices relative to the foregoing are hereby superseded, revoked and rendered ineffective for any purpose.

29.21 Monetary Obligations Subject to Appropriation

All monetary obligations under the Contract Documents are subject to the availability of funds provided to the Mobility Authority by TxDOT, some or all of which may be subject to appropriation by the Texas Legislature or by the United States Congress. In the event that either the Texas Legislature or the United States Congress fails to appropriate funds required to satisfy the monetary obligations under the Contract Documents, the Mobility Authority shall terminate this DB Agreement pursuant to Section 16, and such termination will not be a default by the Mobility Authority. The Mobility Authority shall only be obligated to make payments under the Contract Documents for services rendered through the effective date of any such termination together with the DB Contractor’s termination costs, if any, as contemplated by such Section. The Contract Documents do not create a debt under the Texas Constitution.

IN WITNESS WHEREOF, the Parties have executed this DB Agreement as of the date and year first set forth above.

DB CONTRACTOR: GREAT HILLS CONSTRUCTORS
a joint venture between Archer Western Construction, LLC
and Sundt Construction, Inc.

By: Archer Western Construction, LLC

By: _____
Name: Daniel P. Walsh
Title: President

By: Sundt Construction, Inc.

By: _____
Name: G. Michael Hoover
Title: President & Chief Executive Officer

**MOBILITY AUTHORITY: CENTRAL TEXAS REGIONAL MOBILITY
AUTHORITY**

By: _____
Name: William Chapman
Title: Interim Executive Director & Chief Financial Officer